



Chipsmall Limited consists of a professional team with an average of over 10 year of expertise in the distribution of electronic components. Based in Hongkong, we have already established firm and mutual-benefit business relationships with customers from,Europe,America and south Asia,supplying obsolete and hard-to-find components to meet their specific needs.

With the principle of “Quality Parts,Customers Priority,Honest Operation,and Considerate Service”,our business mainly focus on the distribution of electronic components. Line cards we deal with include Microchip,ALPS,ROHM,Xilinx,Pulse,ON,Everlight and Freescale. Main products comprise IC,Modules,Potentiometer,IC Socket,Relay,Connector.Our parts cover such applications as commercial,industrial, and automotives areas.

We are looking forward to setting up business relationship with you and hope to provide you with the best service and solution. Let us make a better world for our industry!



## Contact us

Tel: +86-755-8981 8866 Fax: +86-755-8427 6832

Email & Skype: info@chipsmall.com Web: www.chipsmall.com

Address: A1208, Overseas Decoration Building, #122 Zhenhua RD., Futian, Shenzhen, China



# NB3x6x1xxG8DFNEVK

## NB3x6x1xxG8DFN OmniClock Evaluation Kit Manual



ON Semiconductor®

[www.onsemi.com](http://www.onsemi.com)

### EVAL BOARD USER'S MANUAL

#### Devices Supported

- NB3H60113G (DFN8, 3.3 V)
- NB3V60113G (DFN8, 1.8 V)

#### Introduction

NB3x6x1xxG8DFNEVK is an evaluation kit offering a convenient solution for evaluating DFN8 devices. Included are one main board, a daughter board, and a USB cable. The main board and daughter board are 4 layer boards with dedicated power and GND planes.

The daughter board plugs directly on to the main board using four 4-pin header connectors. These connectors route the signal, power and ground to the device on the daughter board. The two boards correctly plug into one another in only one orientation ensuring proper pin alignment. The daughter board has a DFN8 socket to test NB3x6x1xxG devices. A view of the main board with the DFN8 daughter board is shown in Figures 1 and 2.

The Clock Cruiser Software is the GUI software developed to be used with this evaluation kit, and can be downloaded for free from [www.onsemi.com](http://www.onsemi.com). It allows the user to set programmable parameters and generate solutions that fit application needs. These solutions can then be programmed in to device's OTP memory or be temporarily written into device registers for evaluation. For more information on using the GUI, refer to Clock Cruiser User Guide.

#### Description

The NB3x6x1xxG, which is a member of the OmniClock family, is a versatile user programmable clock generator designed by ON Semiconductor with customer experience in mind. These devices are tailored to fit into an extensive array of applications including wearable technology, smart phones, digital cameras, E-books, portable electronics, and Internet of Things. The NB3H designated parts are powered by 3.3 V and 2.5 V supplies while NB3V parts support 1.8 V operation.

These devices are One Time Programmable (OTP), low power PLL based clock generators that accept fundamental mode parallel resonant crystals of up to 50 MHz or a single ended LVCMOS/LVTTL reference clock input of up to 200 MHz. The outputs can be configured as either three single ended LVCMOS/LVTTL outputs or a combination of one single ended output and one differential LVPECL/LVDS/HCSL/CML output. The generated clock output's frequency can range between 8 kHz to 200 MHz.

Other programmable parameters include internal crystal load capacitor, drive strength for LVCMOS outputs, output frequency modulation controls (type, depth, modulation rate), output phase inversion, and PLL bypass mode. The devices are fully functional between  $-40^{\circ}\text{C}$  to  $+85^{\circ}\text{C}$ .

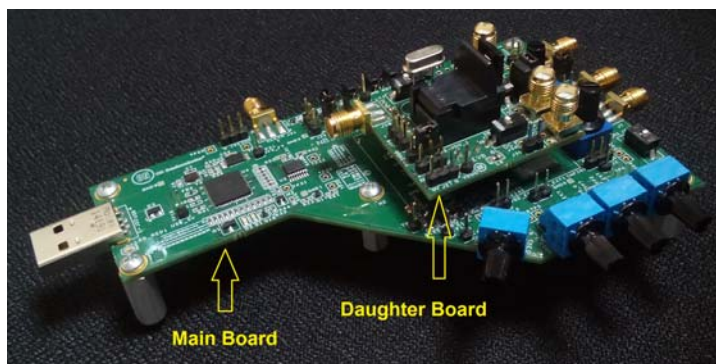

Figure 1. 45° View of Main Board with DFN8 Daughter Board

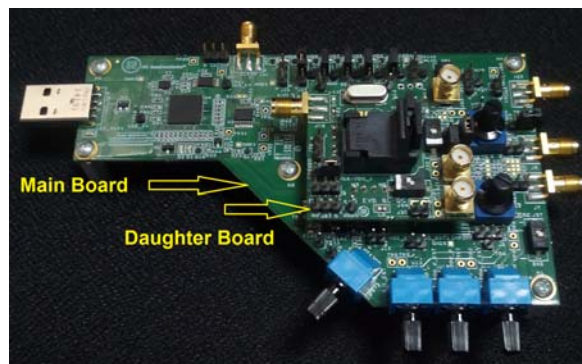

Figure 2. Top View of Main Board with DFN8 Daughter Board

# NB3x6x1xxG8DFNEVK

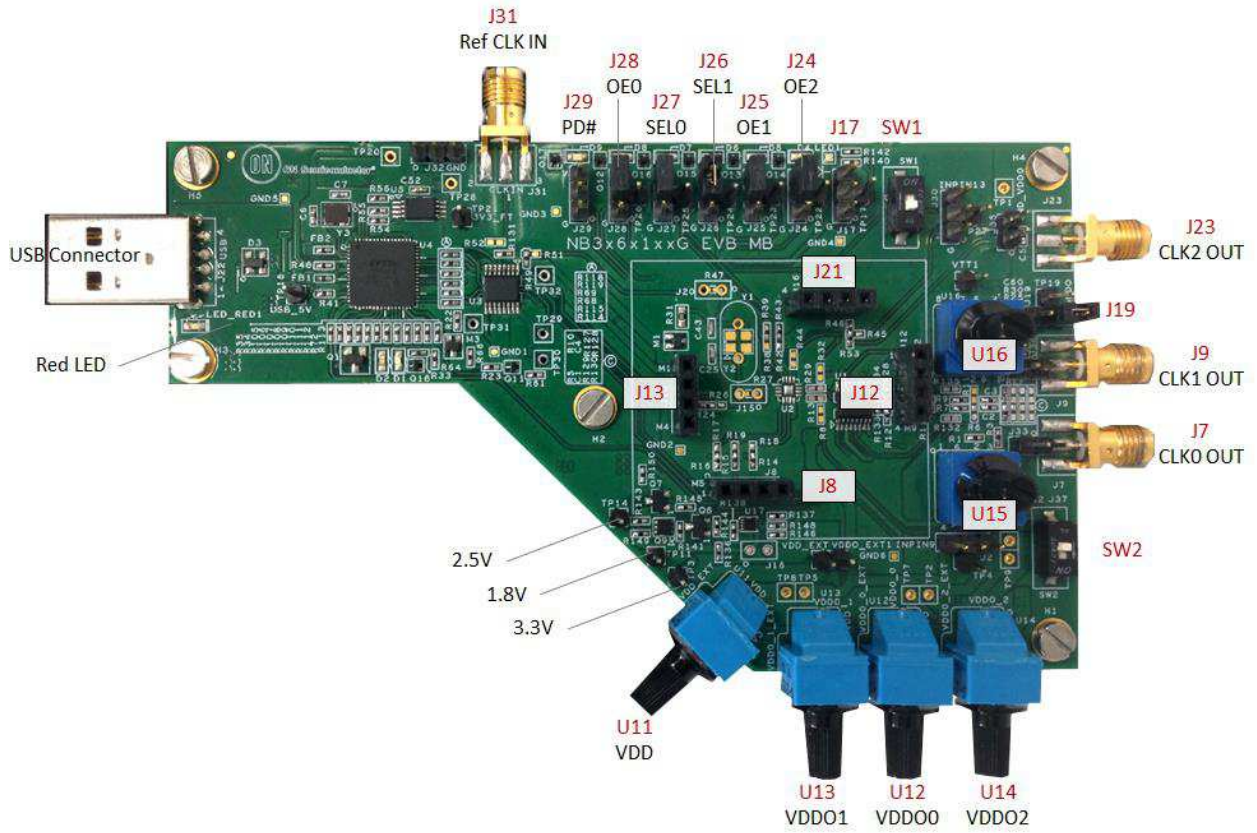

Figure 3. Main Board

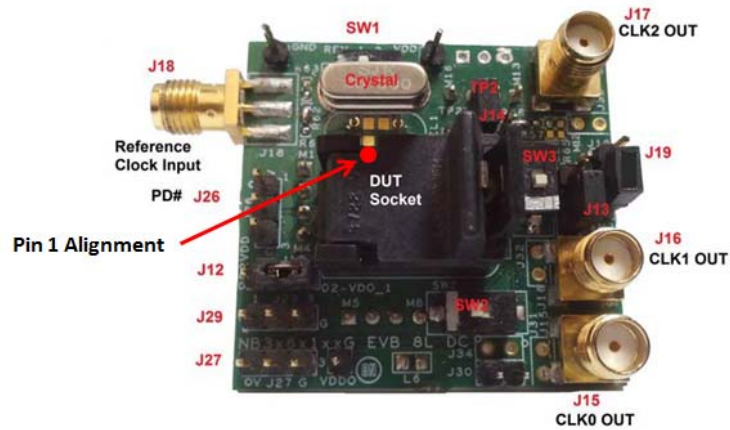

Figure 4. DFN8 Daughter Board

# NB3x6x1xxG8DFNEVK

## Step 1: Hardware Setup

Note: Skip this section if device has already been programmed.

### Main Board

1. Securely connect the daughter board to the main board by lining up all four 4–pin connectors (J8, J12, J13, J21). The daughter board can only be plugged in to the main board correctly in one orientation.
2. Make sure all SMA cables are unplugged from main board and daughter board.
3. Jumpers:
  - a. Use jumpers to provide connection as referenced in table below: (Pin 1 is indicated by a circle)

Jumper No	J26 (SEL1)	J27 (SEL0)	J24 (OE2)	J25 (OE1)	J28 (OE0)	J29 (PD#)	J19
Pin connection	2 and 3	2 and 3	2 and 3	2 and 3	2 and 3	OPEN	2 and 3

4. Switches:
  - a. Slide switches to the position referenced in table below: (ON position is indicated via lettering on switch)

Switch No	SW1	SW2
Position	ON	ON

5. Rotary Switches:
  - a. Turn knob on rotary switches as shown in table below: (The position number will be displayed in a slit on the knob)

Jumper No	U11	U12	U13	U14	U15	U16
Dial Display	1	1	1	1	1	1

### Daughter Board

1. Jumpers:
  - a. Use Jumpers to provide connection as referenced in table below: (Pin 1 is indicated by a circle)

Jumper No	J31 (SEL1)	J30 (SEL0)	J29 (OE2)	J28 (OE1)	J27 (OE0)	J26 (PD#)
Shorting Link Position	OPEN	OPEN	OPEN	OPEN	OPEN	OPEN

2. Switches:
  - a. Slide switches to the position referenced in table below: (ON position is indicated via lettering on switch)

Switch No	SW1	SW2	SW3
Position	ON	ON	ON

3. Ensure that Crystal (XTAL) is in holder.
4. Place NB3H60113G or NB3V60113G in DUT socket U2. For device pin 1 alignment refer to Figure 4.

# NB3x6x1xxG8DFNEVK

## Step 2: Device Programming

Note: Skip this section if device has already been programmed

1. Download and install Clock Cruiser GUI Software to a computer that meets or exceeds minimum requirements found on Clock Cruiser User guide.
2. Connect the evaluation kit to an USB port using included USB cable. A LED next to the USB connector will glow red, indicating that +5 V supply has been applied to EVB.
3. Run the Clock Cruiser GUI software. A blue LED (D9) will light up when a connection is established, this LED will blink periodically as activity is being conducted.
4. Follow the Clock Cruiser User Guide for detailed instructions on navigating through the program to properly configure device.
5. In the device programming screen, a table indicates the summary of configurations that were selected. Verify that the Hardware Connected indicator is green and that there is no error in the log.
6. Set appropriate device VDD/VDDO levels.
  - a. Set VDD and VDDO for each output by using the four rotary switches (U11, U12, U13, and U14) located on the main board to match device configuration. Make sure that VDDO's are less than or equal to VDD. The following table shows which on-board LDO voltage is selected depending on the switch position (see table below).

Rotary Switch	Line	Voltage for Each Switch Position			
		1	2	3	4
U11	VDD	+3.3 V	+2.5 V	+1.8 V	external source
U12	VDDO0	VDD			
U13	VDDO1				
U14	VDDO2				

7. Program the device permanently by selected [Program OTP Memory] or write to device registers by clicking [Write to Registers]. In the case Write to Register function is utilized, powering down evaluation kit (i.e. unplugging USB cable) will reset device registers.

## Step 3: Device Evaluation

### Select Input Clock

Depending on the programmed configuration, select one of the following input clock references.

1. Crystal (XTAL): The evaluation kit comes equipped with a 25 MHz fundamental crystal on the daughter board. If a different frequency is required, place new crystal in holder. Device can accept 3 MHz to 50 MHz crystal references. Please follow the additional step below to properly use Crystal as input reference:
  - a. Place SW1 on daughter board in the OFF position.
2. External Clock Reference: To use an external clock reference, connect external clock to SMA connector J31 on the main board. Device can accept 3 MHz to 200 MHz clock references, reference device datasheet for appropriate input levels.

Please follow additional steps below to properly use an external clock input source:

- a. Close out GUI software to stop communication between GUI and EVB.
- b. Unplug and Re-plug EVB to USB port.
- c. Manually supply power to device with PD# pin. (See section *Controlling the Device (GPIO pins)* for proper use of PD# pin)

Note: External Clock can only be used with devices that have been OTP'd.

# NB3x6x1xxG8DFNEVK

## Select Output Termination

DUT outputs are routed to three SMA connectors on the main board (J7, J9, and J23) to provide termination for CLK0, CLK1, and CLK2 respectively. By turning rotary switches U15 and U16, the board will automatically terminate the programmed output level for CLK0 and CLK1, to its respective output termination in table below.

Rotary Switch Position	U15 output for CLK0	U16 output for CLK1
1	LVC MOS	LVC MOS
2	HC SL	HC SL
3	LVPECL	LVPECL
4	CML	CML
5	LVDS	LVDS

Note: CLK2 output only supports LVC MOS levels; therefore its termination is fixed.

## Interfacing with Test Equipment

Monitor DUT outputs from main board with an oscilloscope with either SMA connectors or on board jumpers.

1. To use SMA connectors (J7, J9, J23), use oscilloscopes Hi-Z feature or a Hi-Z probe to monitor outputs. (Ensure probe is properly grounded)
2. To use Jumpers (J33, J34, J35), use a Hi-Z probe connected to jumper pin marked 0. (Ensure probe is properly grounded)

Both options can be used to monitor all three DUT outputs.

## Controlling the Device (GPIO pins)

The device has multiple functions that can be programmed via control pins, below is a list of control pins and their respective SMA connector.

**OE:** Pin used to enable or disable outputs individually. The main and daughter boards both have OE pins that can be easily accessed via jumpers.

Main board: CLK0=J28, CLK1=J25, CLK2=J24

Daughter board: CLK0=J27, CLK1=J28, CLK2=J29

OE	Function
0	CLK Disabled
1	CLK Enabled

**PD#:** Pin used to power down device, this pin can be controlled either with J29 (main board) or J26 (daughter board). The logic state of this signal corresponds to the LED (D9) on the main board.

PD#	Function	LED (D9)
0	Device Powered Down	Off
1	Device Powered Up	On

## NB3x6x1xxG8DFNEVK

**SEL:** Pin is used to select between the available four output configurations that can be stored in devices OTP memory.

Main board: SEL0=J27, SEL1=J26

Daughter board: SEL0=J30, SEL1=J31

SEL0	SEL1	Output Configuration
L	L	I
L	H	II
H	L	III
H	H	IV

### Programming Reminders

While communicating between the GUI and device ensure the following:

#### Main Board

1. Switches SW1 and SW2 are set to the ON state.
2. Rotary switches U11, U12, U13, U14, U15 and U16 are in the “1” position.
3. All SMA cables are detached from test equipment.

#### Daughter Board

1. Switches SW1, SW2 and SW3 are set to the ON position.
2. All SMA cables are detached from test equipment.

When re-configuring temporary device registers ensure the following:

1. Re-initiate main board hardware setup.
2. Re-initiate daughter board hardware setup.
3. Re-initiate GUI by either returning to previous page with [back] button or restarting GUI software.

Note: Even if device OTP memory has been programmed, device registers can be used to write other solutions for evaluation.

APPENDIX

Unpopulated Boards

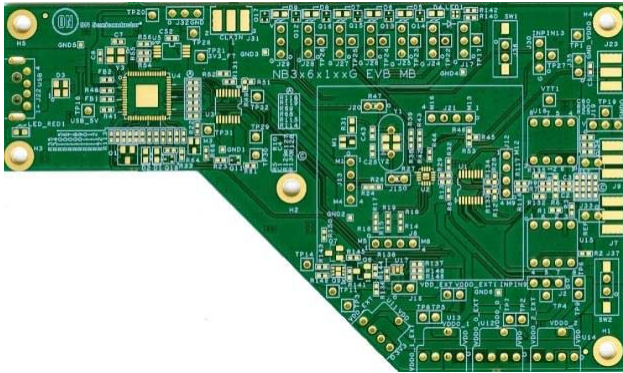

Figure 5. Main Board Top View

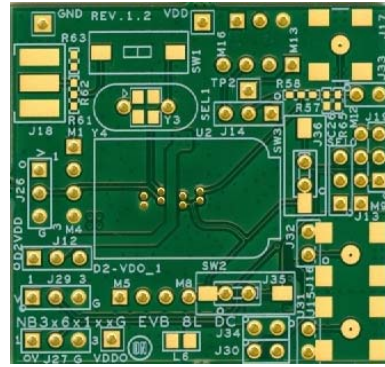

Figure 7. DFN8 Daughter Board Top View

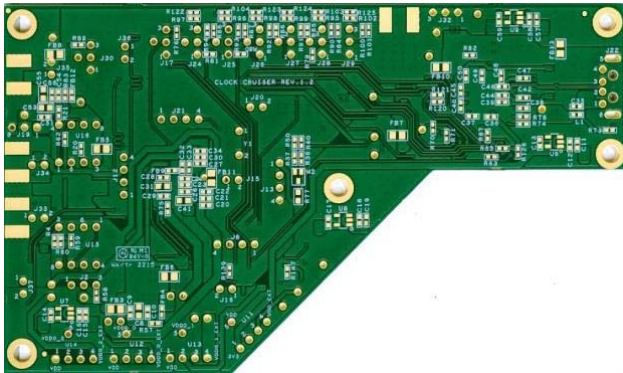

Figure 6. Main Board Bottom View

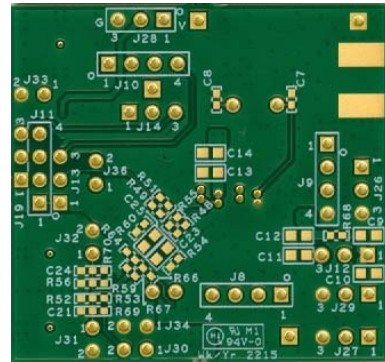
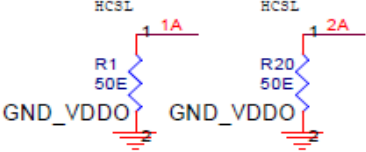

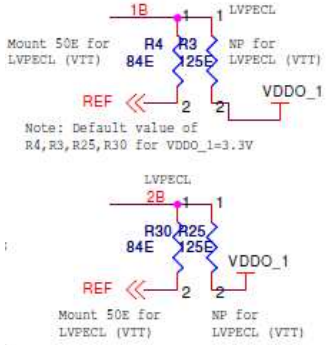
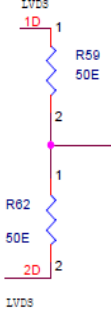

Figure 8. DFN8 Daughter Board Bottom View



# NB3x6x1xxG8DFNEVK

## OUTPUT TERMINATION

<p>HCSL</p>	
<p>CML</p>	
<p>LVPECL</p>	 <p>Mount 50Ω for LVPECL (VTT)</p> <p>NP for LVPECL (VTT)</p> <p>Note: Default value of R4, R3, R25, R30 for VDDO_1=3.3V</p> <p>Mount 50Ω for LVPECL (VTT)</p> <p>NP for LVPECL (VTT)</p>
<p>LVDS</p>	



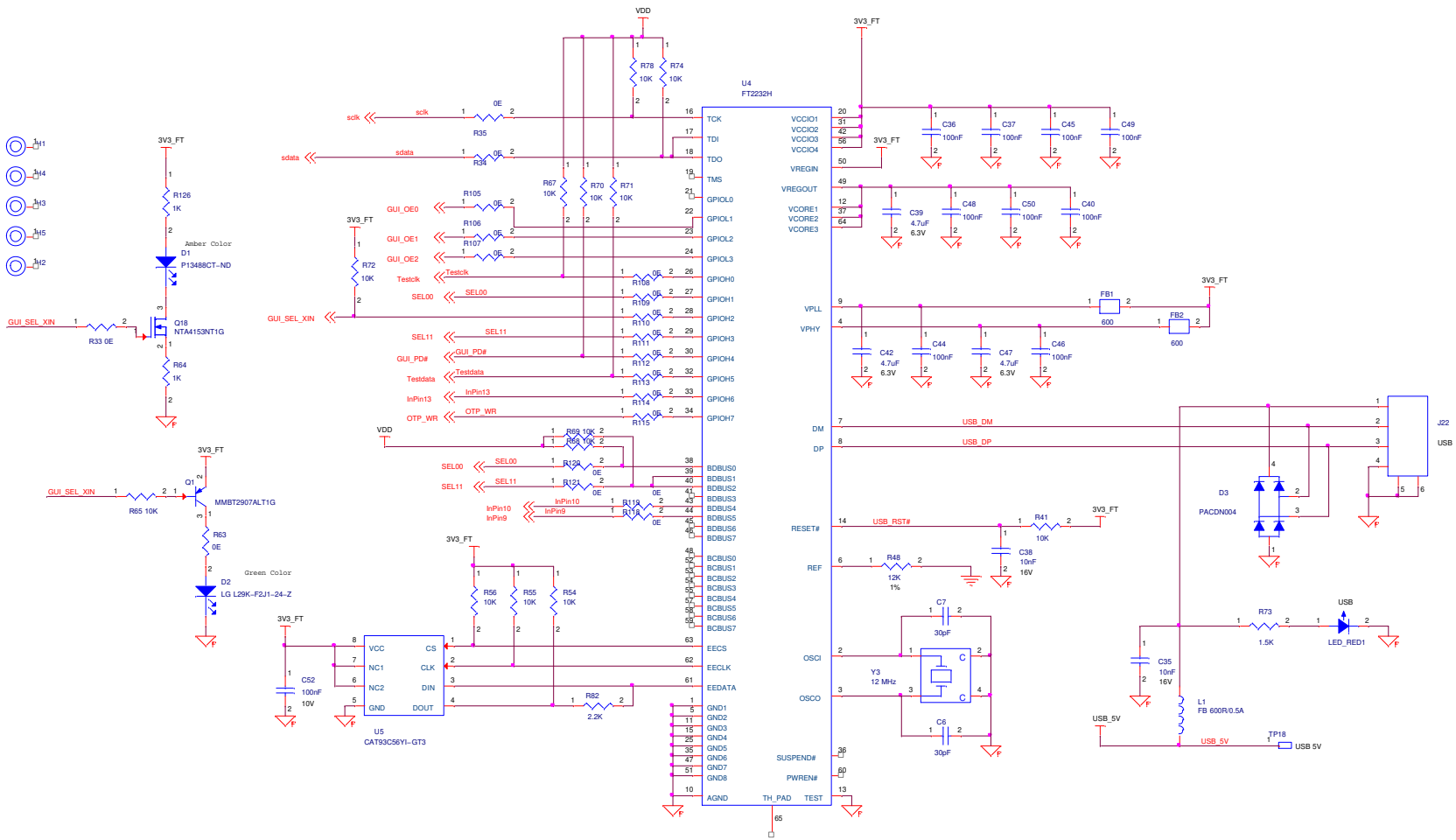

Figure 10. Main Board Schematic (2 of 3)

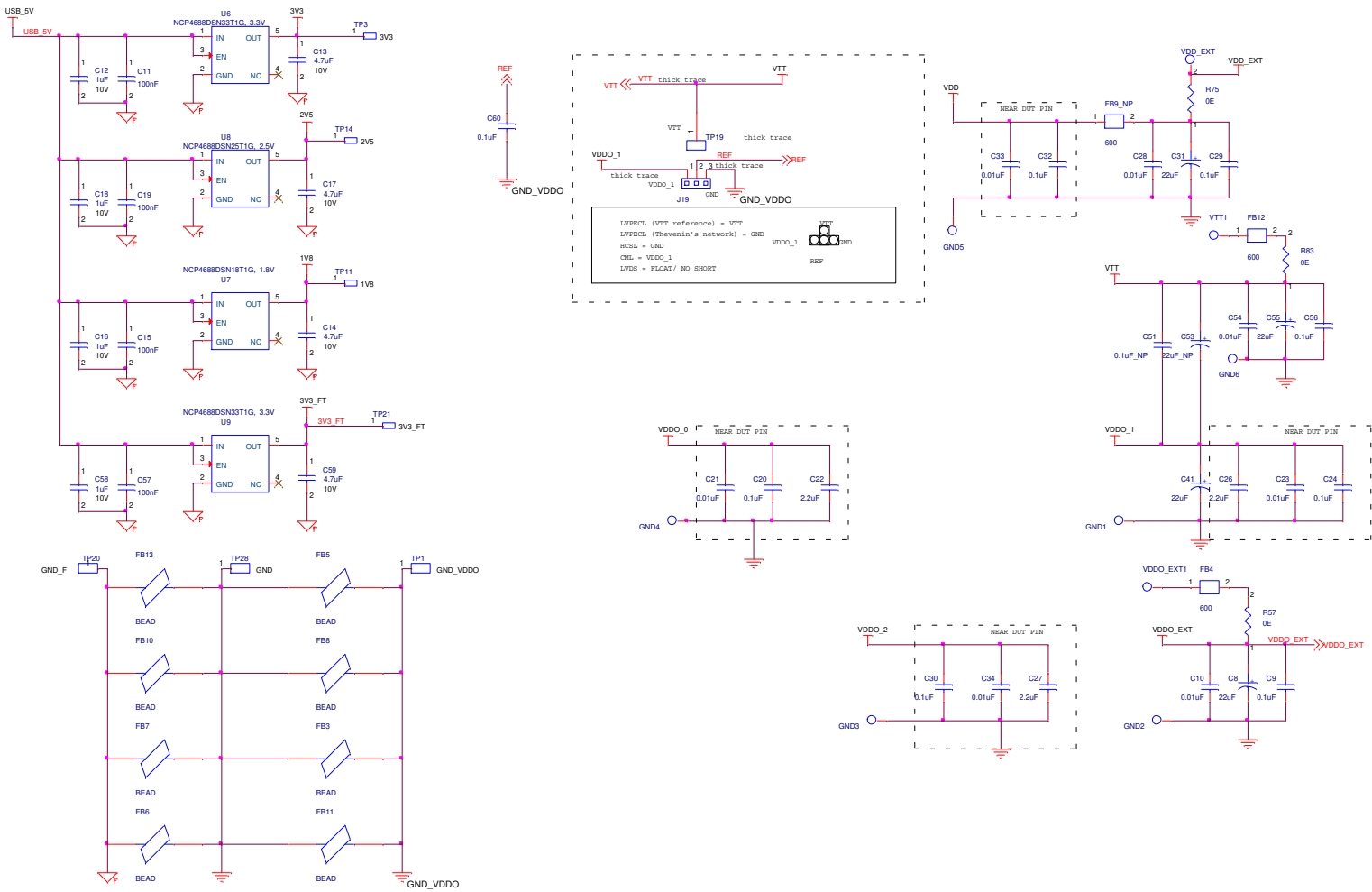

Figure 11. Main Board Schematic (3 of 3)

# NB3x6x1xxG8DFNEVK

## DFN8 Daughter Board Schematic

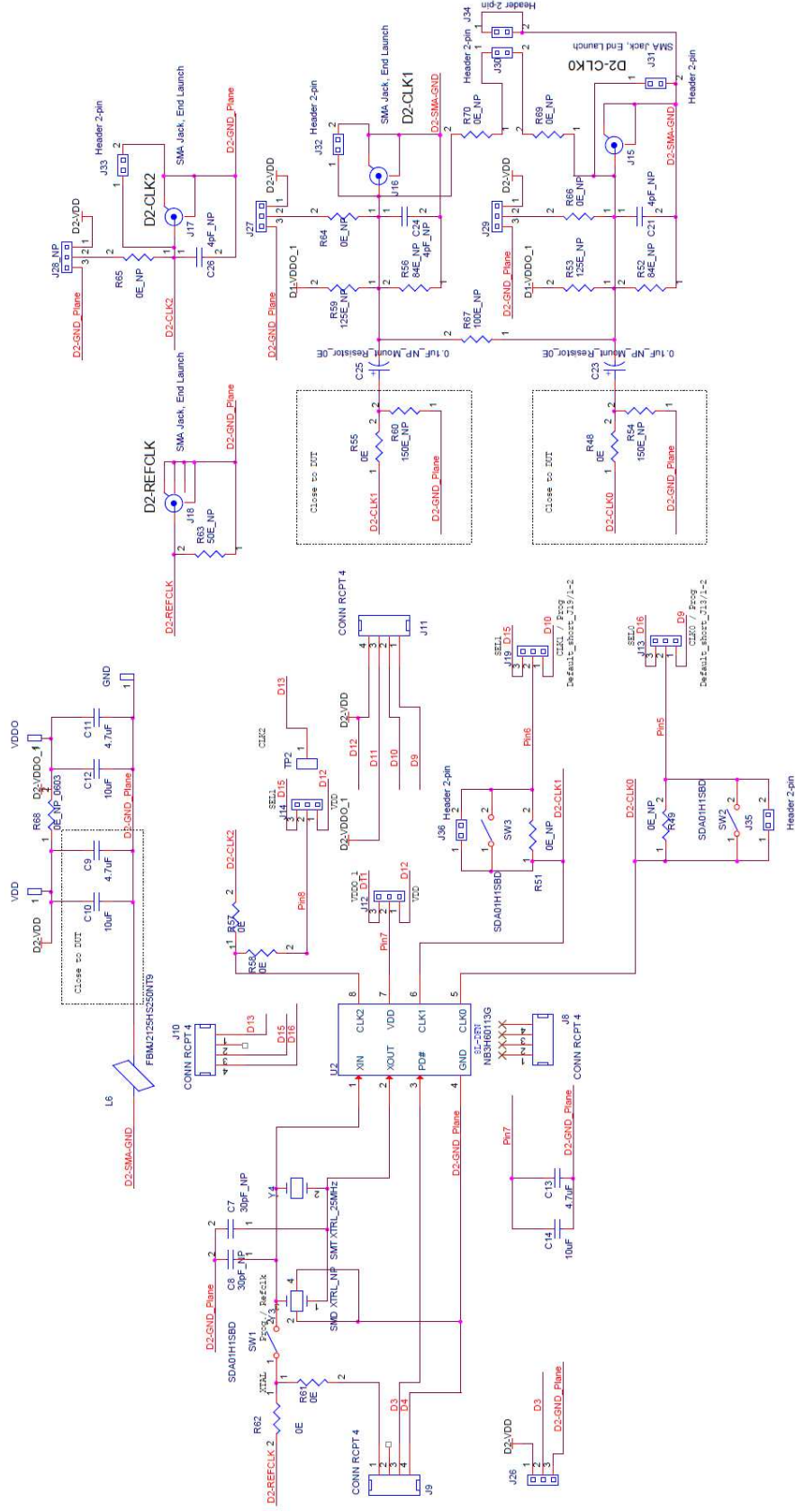

Figure 12. DFN8 Daughter Board Schematic

# NB3x6x1xxG8DFNEVK

## BILL OF MATERIAL MAIN BOARD

SI No	Reference	Part	PCB Footprint	Vendor	Vendor PN	Manufacturer	Manufacturer Part#	Description	Qty	Notes / Remarks
1	C2,C3	0.01 $\mu$ F _Mount R0E	R0402	DigiKey	541-0.0JCT-ND	Vishay Dale	CR-CW0402000Z0ED	RES SMD 0.0 OHM JUMPER 1/16W	2	
2	C8,C31, C41,C55	22 $\mu$ F	C0603	DigiKey	587-2085-1-ND	Taiyo Yuden	AMK107BJ226MA-T	CAP CER 22UF 4V 20% X5R 0603	4	
3	C9,C20, C24,C29, C30,C32, C56,C60	0.1 $\mu$ F	C0402	DigiKey	587-1227-1-ND	Taiyo Yuden	LMK105BJ104KV-F	CAP CER 0.1UF 10V 10% X5R 0402	8	
4	C10,C21, C23,C28, C33,C34, C54	0.01 $\mu$ F	C0402	DigiKey	490-1312-1-ND	Murata	GRM155R71E103KA01-D	CAP CER 10000PF 25V 10% X7R 0402	7	
5	C11,C15, C19,C36, C37,C40, C44,C45, C46,C48, C49,C50, C52,C57	100 nF	C0402	DigiKey	478-1129-1-ND	AVX	0402ZD104-KAT2A	CAP CER 0.1UF 10V 10% X5R 0402	14	
6	C12,C16, C18,C58	1 $\mu$ F	C0402	DigiKey	490-5409-1-ND	Murata	GRM155R61A105ME15-D	CAP CER 1UF 10V 20% X5R 0402	4	
7	C13,C14, C17,C59	4.7 $\mu$ F	C0402	DigiKey	490-5408-1-ND	Murata	GRM155R60J475ME87-D	CAP CER 4.7UF 6.3V 20% X5R 0402	4	
8	C22,C26, C27	2.2 $\mu$ F	C0402	DigiKey	490-4518-1-ND	Murata	GRM155R60G225ME15-D	CAP CER 2.2UF 4V 20% X5R 0402	3	
9	C35,C38	10 nF	C0402	DigiKey	478-1114-1-ND	AVX	0402YC103-KAT2A	CAP CER 10000PF 16V 10% X7R 0402	2	
10	C39,C42, C47	4.7 $\mu$ F	C0402	DigiKey	490-5408-1-ND	Murata	GRM155R60J475ME87-D	CAP CER 4.7UF 6.3V 20% X5R 0402	3	
11	D1	LED_amber	LED_0603	DigiKey	P13488CT-ND	Panasonic	LNJ414K82-RA	LED AMBER HIGH BRIGHT USS 0603	1	
12	D2,D4,D5, D6,D7,D8	LED_green-LG L29K-F2J1-24-Z	LED_0603	DigiKey	475-3118-1-ND	OSRAM Opto Semiconductors Inc	LG L29K-F2J1-24-Z	LED SMARTLED 570NM GREEN 0603	6	
13	D3	PACDN004S-R	SOT-143	Mouser	748-PACDN004SR	ON Semi			1	
14	D9	LB Q39G-L2N2-35-1	LED_0603	DigiKey	475-2816-1-ND	OSRAM Opto Semiconductors Inc	LB Q39G-L2N2-35-1	LED CHIPLED BLUE 470NM 0603 SMD	1	
15	FB1,FB2, FB4,FB12	600	L0402	DigiKey	490-1006-1-ND	Murata	BLM15AG601SN1D	FERRITE CHIP 600 OHM 300MA 0402	4	
16	FB3,FB5, FB6,FB7, FB8,FB10, FB11,FB13	BEAD	L0805	DigiKey	587-1767-1-ND	Taiyo Yuden	FB-MJ2125HS250NT	FERRITE BEAD 25 OHM 0805	8	
17	GND1, GND2, GND3, GND4, GND5, GND6	T POINT R	TP_30_30	NA	NA	NA	NA	NA	6	Test Point
18	H1,H2,H3, H4,H5	.129 Hole in .240 Round Pad	MH_240_128	NA	NA	NA	NA	NA	5	Round Pad
19	J2,J17,J19, J24,J25, J26,J27, J28,J29, J30,J32	Header 3-pin	berg_1x3_2p54	DigiKey	3M9448-ND	3M	961103-6404-AR	CONN HEADER VERT SGL 3POS GOLD	11	
20	J7,J9,J23, J31	SMA- J-P-H-ST-EM1-ND	con_sma_e-dge	DigiKey	SMA- J-P-H-ST-EM1	Samtec Inc	SMA- J-P-H-ST-EM1	CONN SMA JACK 50 OHM EDGE MNT	4	
21	J8,J12, J13,J21	4 HEADER	berg_1x4_2p54	DigiKey	S7037-ND	Sullins Connector Solutions	PP-PC041LF-BN-RC	Connector Header 4 Position 0.100" (2.54mm) Gold Through Hole	4	

# NB3x6x1xxG8DFNEVK

## BILL OF MATERIAL MAIN BOARD

SI No	Reference	Part	PCB Footprint	Vendor	Vendor PN	Manufacturer	Manufacturer Part#	Description	Qty	Notes / Remarks
22	J15,J16, J20,J33, J34,J35, J36,J37	SMDHeader 2-pin	berg_1x2_2p54	DigiKey	3M5350-ND	3M	151204-2320-RB	CONN 4POS 2MM HEADER DL STR SMD	8	
23	J22	Conn. USB-B, SMT	USB_A_-PLUG_RA	DigiKey	WM17117-ND	Molex	480370001	Connector Plug USB TypeA 2.0 4 Position Through Hole, Right Angle, Horizontal	1	
24	LED_RED1	LED, Green	LED_0603	DigiKey	P11475CT-ND	Panasonic	LNJ212R82-RA	LED RED TSS TYPE 0603	1	
25	LED1	846-1040-1-ND	LED_SM-L_DUO	DigiKey	846-1040-1-ND	Rohm Semiconductor	SML-P24MUWT86	LED PICOLED DUAL YWGN/RED 1010	1	
26	L1	FB 600R/0.5A	L0402	DigiKey	490-5258-1-ND	Murata	BLM18KG601SN1D	FERRITE CHIP 600 OHM 1300MA 0603	1	
27	M1,M2,M3	NTS2101P/ON	sot-323	DigiKey	NTS2101PT1-GOSCT-ND	ON Semi	NTS2101PT1G	MOSFET P-CH 8V 1.4A SOT-323	3	
28	Q1	MMBT2907A-LT1G	sot_23	DigiKey	MMBT2907ALT3GOSCT-ND	ON Semi	MMBT2907-ALT3G	TRANS PNP 60V 0.6A SOT-23	1	
29	Q6,Q7	50C02CH-TL-E	sot-23	DigiKey	50C02CH-TL-EOSCT-ND	ON Semi	50C02CH-TL-E	TRANS NPN 50V 0.5A CPH3	2	
30	Q9	NTLJD3115PT1G	6-WDFN (2X2)	DigiKey	NTLJD3115PT1GOSCT-ND	ON Semi	NTLJD3115PT1G	MOSFET 2P-CH 20V 2.3A 6-WDFN	1	
31	Q11,Q12, Q13,Q14, Q15,Q16, Q17,Q18	NTA4153NT1G	sot-416	DigiKey	NTA4153NT1-GOSCT-ND	ON Semi	NTA4153NT1G	MOSFET N-CH 20V 915MA SOT-416	8	
32	R1,R2, R20,R21, R36,R40, R59,R62	50E	R0402	DigiKey	P49.9LDKR-ND	Panasonic	ERJ-2RKF49R9X	RES SMD 49.9 OHM 1% 1/10W 0402	8	
33	R3,R25	125E	R0402	DigiKey	P124LCT-ND	Panasonic	ERJ-2RKF1240X	RES SMD 124 OHM 1% 1/10W 0402	2	
34	R4,R30	84E	R0402	DigiKey	P84.5LCT-ND	Panasonic	ERJ-2RKF84R5X	RES SMD 84.5 OHM 1% 1/10W 0402	2	
35	R5,R10, R12,R14, R15,R16, R24,R28, R33,R34, R35,R39, R43,R46, R49,R57, R63,R75, R83,R84, R85,R86, R87,R88, R90,R91, R92,R93, R94,R100, R101,R105,- R106,R107,- R108,R109,- R110,R111, R112,R113, R114,R115, R118,R119, R120,R121, R131	0E	R0402	DigiKey	541-0.0JCT-ND	Vishay Dale	CR-CW04020000Z0ED	RES SMD 0.0 OHM JUMPER 1/16W	47	
36	R7,R9,R53	0E	R0402	DigiKey	541-0.0JCT-ND	Vishay Dale	CR-CW04020000Z0ED	RES SMD 0.0 OHM JUMPER 1/16W	3	
37	R116,R117, R149	0E	R0402	DigiKey	541-0.0JCT-ND	Vishay Dale	CR-CW04020000Z0ED	RES SMD 0.0 OHM JUMPER 1/16W	3	

# NB3x6x1xxG8DFNEVK

## BILL OF MATERIAL MAIN BOARD

SI No	Reference	Part	PCB Footprint	Vendor	Vendor PN	Manufacturer	Manufacturer Part#	Description	Qty	Notes / Remarks
38	R22,R41, R54,R55, R56,R58, R61,R65, R67,R68, R69,R70, R71,R72, R74,R76, R78,R79, R80,R81, R89,R136, R150	10K	R0402	DigiKey	P10KJCT-ND	Panasonic	ERJ-2GEJ1 03X	RES SMD 10K OHM 5% 1/10W 0402	23	
39	R23,R82	2.2K	R0402	DigiKey	P2.2KJCT-ND	Panasonic	ERJ-2GEJ2 22X	RES SMD 2.2K OHM 5% 1/10W 0402	2	
40	R31,R77	82E	R0603	DigiKey	541-82.0HC- T-ND	Vishay Dale	CR- CW060382R 0FKEA	RES SMD 82 OHM 1% 1/10W 0603	2	
41	R37,R50	50K	R0402	DigiKey	P10KJCT-ND	Panasonic	ERJ-2GEJ1 03X	RES SMD 10K OHM 5% 1/10W 0402	2	
42	R48	12K	R0402	DigiKey	P12.0KLCT- ND	Panasonic	ERJ-2RKF1 202X	RES SMD 12K OHM 1% 1/10W 0402	1	
43	R64,R66, R103,R104,- R122,R123,- R124,R125,- R126, R141,R143, R140,R142	1K	R0402	DigiKey	P1.0KJCT-ND	Panasonic	ERJ-2GEJ1 02X	RES SMD 1K OHM 5% 1/10W 0402	13	
44	R73	1.5K	R0402	DigiKey	P1.5KJCT-ND	Panasonic	ERJ-2GEJ1 52X	RES SMD 1.5K OHM 5% 1/10W 0402	1	
45	R137,R138	22K	R0402	DigiKey	P22KJCT-ND	Panasonic	ERJ-2GEJ2 23X	RES SMD 22K OHM 5% 1/10W 0402	2	
46	R148	8.2K	R0402	DigiKey	P8.2KJCT-ND	Panasonic	ERJ-2GEJ8 22X	RES SMD 8.2K OHM 5% 1/10W 0402	1	
47	R139	47K	R0402	DigiKey	P47KJCT-ND	Panasonic	ERJ-2GEJ4 73X	RES SMD 47K OHM 5% 1/10W 0402	1	
48	R144,R145	33K	R0402	DigiKey	P33KJCT-ND	Panasonic	ERJ-2GEJ3 33X	RES SMD 33K OHM 5% 1/10W 0402	2	
49	R146	3.3K	R0402	DigiKey	P3.3KJCT-ND	Panasonic	ERJ-2GEJ3 32X	RES SMD 3.3K OHM 5% 1/10W 0402	1	
50	SW1,SW2	SDA01H1SB- D		DigiKey	CKN10358-N- D	C&K Components	SDA01H1- SBD	SWITCH DIP TAPE SEALED 1POS 24V	2	
51	TP1,TP2, TP5,TP6, TP7,TP8, TP9,TP20, TP28	Test Pad 50 x 100 mil	NA	NA	NA	NA	NA	NA	9	Test point
52	TP3,TP4, TP11,TP14, TP17,TP18, TP21,TP22, TP23,TP24, TP25,TP26, TP27,TP19	Test Pad 30 x 60 mil	TP_70_36	DigiKey	732-5314-ND	Wurth Electronics Inc	6130011112 1	CONN HEADER 1 POS 2.54	14	
53	U1,U3	ADG3257BR- QZ	QSOP_16- P_25MIL	DigiKey	ADG3257BRQ- Z-ND	Analog Devices	ADG3257BR- QZ	IC MUX QUAD 3.3/5V HS 16-QSOP	2	
54	U2	NB3H63143- G	QFN_16P_ 0P5MM						1	ON Semi- con- ductor part
55	U4	FT2232H	qfn_64_0p 5	DigiKey	768-1025-1- ND	FTDI	FT2232HQ- REEL	IC USB HS DUAL UART/FIFO 64-QFN	1	
56	U5	CAT93C56Y1 -GT3	tssop_8_4p 4w_0p65	Digi-Key	CAT93C56Y1- GT3-ND	ON Semi	CAT93C56Y1 -GT3	IC EEPROM 2KBIT 2MHZ 8TSSOP	1	
57	U6,U9	NCP4688DS- N33T1G, 3.3 V	sot23-5	ON Semi	NCP4688DSN 33T1GOSCT- ND	ON Semi	NCP4688DS- N33T1G	IC REG LDO 3.3V 0.15A SOT23-5	2	
58	U7	NCP4688DS- N18T1G, 1.8 V	sot23-5	ON Semi	NCP4688DSN 18T1GOSCT- ND	ON Semi	NCP4688DS- N18T1G	IC REG LDO 1.8V 0.15A SOT23-5	1	
59	U8	NCP4688DS- N25T1G, 2.5 V	sot23-5	ON Semi	NCP4688DSN 25T1GOSCT- ND	ON Semi	NCP4688DS- N25T1G	IC REG LDO 2.5V 0.15A SOT23-5	1	



# NB3x6x1xxG8DFNEVK

## BILL OF MATERIAL MAIN BOARD

SI No	Reference	Part	PCB Footprint	Vendor	Vendor PN	Manufacturer	Manufacturer Part#	Description	Qty	Notes / Remarks
60	U11,U12, U13,U14	S-2151		DigiKey	563-1088-ND	Copal Electronics	S-2151	SW ROTARY DIP SP4T SIDE KNOB 5V	4	
61	U15,U16	SS-10-15S-P-LE		DigiKey	563-1078-ND	Copal Electronics	SS-10-15S-P-LE	SWITCH ROTARY DIP SP5T TOP 5V	2	
62	U17	NCS2220AM-UT1G	8l_udfn_0P4	DigiKey	NCS2220AMU-T1GOSCT-ND	ON Semi	NCS2220A-MUT1G	IC COMPARATOR DUAL LV 8UDFNF	1	
63	VTT1, VD-DO_EXT1, VDD_EXT	T POINT R	TP_70_36	DigiKey	732-5314-ND	Würth Electronics Inc	61300111121	CONN HEADER 1 POS 2.54	3	
64	Y1	SMT XTRL_25MHZ	CRY_EC-X_6150	ECLIPTEK	ECX615025.000M	ECLIPTEK			1	Based on Crystal values
65	Y3	12 MHz	CRY-ABM8G	DigiKey	535-10901-1-ND	Abracon Corp	ABM8G-12.000MHZ-4Y-T3	Crystal 12.0000MHz 30ppm 10pF 120 Ohm -10°C - 60°C Surface Mount 4-SMD, No Lead (DFN, LCC)	1	
66	H1,H2,H3, H4,H5 (Mechanical)	Standoff, 4-40 1/4 x 5/8	Standoff, 4-40 1/4 x 5/8	DigiKey	1808K-ND	Keystone	1808	HEX STANDOFF 4-40 ALUMINUM 5/8"	5	
67	To be used with these connectors- J24,J25, J26,J27, J28,J19 and as spare.	Shunt	Shunt	DigiKey	3M9580-ND	3M	969102-0000-DA	SHUNT JUMPER .1" BLACK GOLD	11	
68	H1,H2,H3, H4,H5 (Mechanical)	Screw, 4-40 x 0.25, PHP	Screw, 4-40 x 0.25, PHP	DigiKey	H342-ND	Building Fasteners	PMS 440 0025 PH	MACHINE SCREW PAN PHILLIPS 4-40	5	
69	VTT1, VD-DO_EXT1, VDD1	T POINT R	TP_70_36	DigiKey	732-5314-ND	Würth Electronics Inc	61300111121	CONN HEADER 1 POS 2.54	4	
70	To be used with these Switches- U11,U12, U13,U14, U15,U16	Switch Knob Black		DigiKey	563-1089-ND	Copal Electronics	K1	SWITCH KNOB BLACK	6	

# NB3x6x1xxG8DFNEVK

## BILL OF MATERIAL DAUGHTER BOARD

SI No	Reference	Part	PCB Footprint	Vendor	Vendor PN	Manufacturer	Qty
1	C9, C11, C13	4.7 µF	C0603	DigiKey	587-1782-1-ND	Taiyo Yuden	3
2	C23, C25	0E	R0603	DigiKey	541-0.0GCT-ND	Vishay Dale	2
3	C10, C12, C14	10 µF	C0603	DigiKey	587-3383-1-ND	Taiyo Yuden	3
4	VDDO, VDD, GND	Test Pad 30 x 60 mil	TP_70_36	DigiKey	732-5314-ND	Würth Electronics Inc	3
5	J8, J9, J10, J11	CONN RCPT 4	BERG_1X4_2P54	DigiKey	S1011EC-04-ND	Sullins Connector Solutions	4
6	J12, J13, J14, J26, J27, J29, J19	Header 3-pin	BERG_1X3_2P54	DigiKey	3M9448-ND	3M	7
7	J18	SMA-J-P-H-ST-EM1-ND	con_sma_edge	DigiKey	SMA-J-P-H-ST-EM1	Samtec Inc	1
8	J15, J16, J17	CONS-MA001-SMD-G-ND	Con_SMA_SMD	DigiKey	CONS-MA001-SMD-G	Linx Technologies Inc	3
9	L6	FB-MJ2125HS250NT9	L0805	DigiKey	587-1767-1-ND	Taiyo Yuden	1
10	R58, R61, R62, R48, R55, R57	0E	R0402	DigiKey	541-0.0JCT-ND	Panasonic	6
11	SW1, SW2, SW3	SDA01H1SBD		DigiKey	CKN10358-ND	C&K Components	3
12	TP2	TEST POINT	TP_70_36	DigiKey	732-5314-ND	Würth Electronics Inc.	1
13	U2	Socket	SOCK_8L_DFN	Loranger	03722 091 6218A	Loranger	1
14	Y3	SMT XTAL_25MHz	CRY_ECX_6150	ECLIPTEK	ECX-6150-25.000M	ECLIPTEK	1
15	Y3	ED1290-ND	SKT CONTACT	DigiKey	8975-0-15-15-21-27-10-0	Mill-Max	2

ON Semiconductor and  are trademarks of Semiconductor Components Industries, LLC dba ON Semiconductor or its subsidiaries in the United States and/or other countries. ON Semiconductor owns the rights to a number of patents, trademarks, copyrights, trade secrets, and other intellectual property. A listing of ON Semiconductor's product/patent coverage may be accessed at [www.onsemi.com/site/pdf/Patent-Marking.pdf](http://www.onsemi.com/site/pdf/Patent-Marking.pdf). ON Semiconductor reserves the right to make changes without further notice to any products herein. ON Semiconductor makes no warranty, representation or guarantee regarding the suitability of its products for any particular purpose, nor does ON Semiconductor assume any liability arising out of the application or use of any product or circuit, and specifically disclaims any and all liability, including without limitation special, consequential or incidental damages. Buyer is responsible for its products and applications using ON Semiconductor products, including compliance with all laws, regulations and safety requirements or standards, regardless of any support or applications information provided by ON Semiconductor. "Typical" parameters which may be provided in ON Semiconductor data sheets and/or specifications can and do vary in different applications and actual performance may vary over time. All operating parameters, including "Typicals" must be validated for each customer application by customer's technical experts. ON Semiconductor does not convey any license under its patent rights nor the rights of others. ON Semiconductor products are not designed, intended, or authorized for use as a critical component in life support systems or any FDA Class 3 medical devices or medical devices with a same or similar classification in a foreign jurisdiction or any devices intended for implantation in the human body. Should Buyer purchase or use ON Semiconductor products for any such unintended or unauthorized application, Buyer shall indemnify and hold ON Semiconductor and its officers, employees, subsidiaries, affiliates, and distributors harmless against all claims, costs, damages, and expenses, and reasonable attorney fees arising out of, directly or indirectly, any claim of personal injury or death associated with such unintended or unauthorized use, even if such claim alleges that ON Semiconductor was negligent regarding the design or manufacture of the part. ON Semiconductor is an Equal Opportunity/Affirmative Action Employer. This literature is subject to all applicable copyright laws and is not for resale in any manner.

### PUBLICATION ORDERING INFORMATION

#### LITERATURE FULFILLMENT:

Literature Distribution Center for ON Semiconductor  
 19521 E. 32nd Pkwy, Aurora, Colorado 80011 USA  
**Phone:** 303-675-2175 or 800-344-3860 Toll Free USA/Canada  
**Fax:** 303-675-2176 or 800-344-3867 Toll Free USA/Canada  
**Email:** [orderlit@onsemi.com](mailto:orderlit@onsemi.com)

**N. American Technical Support:** 800-282-9855 Toll Free  
 USA/Canada  
**Europe, Middle East and Africa Technical Support:**  
 Phone: 421 33 790 2910  
**Japan Customer Focus Center**  
 Phone: 81-3-5817-1050

**ON Semiconductor Website:** [www.onsemi.com](http://www.onsemi.com)  
**Order Literature:** <http://www.onsemi.com/orderlit>  
 For additional information, please contact your local Sales Representative