



Chipsmall Limited consists of a professional team with an average of over 10 year of expertise in the distribution of electronic components. Based in Hongkong, we have already established firm and mutual-benefit business relationships with customers from,Europe,America and south Asia,supplying obsolete and hard-to-find components to meet their specific needs.

With the principle of “Quality Parts,Customers Priority,Honest Operation,and Considerate Service”,our business mainly focus on the distribution of electronic components. Line cards we deal with include Microchip,ALPS,ROHM,Xilinx,Pulse,ON,Everlight and Freescale. Main products comprise IC,Modules,Potentiometer,IC Socket,Relay,Connector.Our parts cover such applications as commercial,industrial, and automotives areas.

We are looking forward to setting up business relationship with you and hope to provide you with the best service and solution. Let us make a better world for our industry!



## Contact us

Tel: +86-755-8981 8866 Fax: +86-755-8427 6832

Email & Skype: info@chipsmall.com Web: www.chipsmall.com

Address: A1208, Overseas Decoration Building, #122 Zhenhua RD., Futian, Shenzhen, China



# NB6L72MMNGEVB

## NB6L72MMNG Evaluation Board User's Manual



ON Semiconductor®

<http://onsemi.com>

### EVAl BOARD USER'S MANUAL

#### Introduction

ON Semiconductor has developed the QFN16EVB evaluation board for its high-performance devices packaged in the 16-pin QFN. This evaluation board was designed to provide a flexible and convenient platform to quickly evaluate, characterize and verify the operation of various ON Semiconductor products. Many QFN16EVBs are dedicated with a device already installed, and can be ordered from [www.onsemi.com](http://www.onsemi.com) at the specific device web page.

This evaluation board manual contains:

- Information on 16-lead QFN Evaluation Board
- Assembly Instructions
- Appropriate Lab Setup
- Bill of Materials

This user's manual provides detailed information on board contents, layout and its use. It should be used in conjunction with an appropriate ON Semiconductor device datasheet located at [www.onsemi.com](http://www.onsemi.com). The datasheet contains the technical device specifications.

#### Board Layout

The QFN16 Evaluation Board provides a high bandwidth,  $50\ \Omega$  controlled impedance environment and is implemented in four layers. The first layer or primary trace layer is 0.008" thick Rogers RO4003 material, and is designed to have equal electrical length on all signal traces from the device under test (DUT) pins to the SMA connectors. The second layer is the 1.0 oz copper ground plane and is primarily dedicated for the SMA connector ground plane. FR4 dielectric material is placed between the second and third layers and between third and fourth layers. The third layer is also 1.0 oz copper plane. A portion of this layer is designated for the device  $V_{CC}$  and DUTGND power planes. The fourth layer is the secondary trace layer.

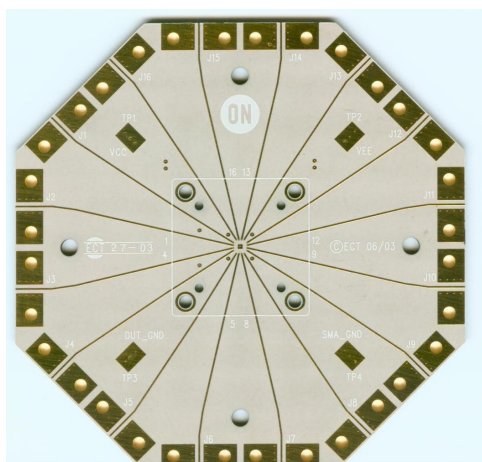

Top View

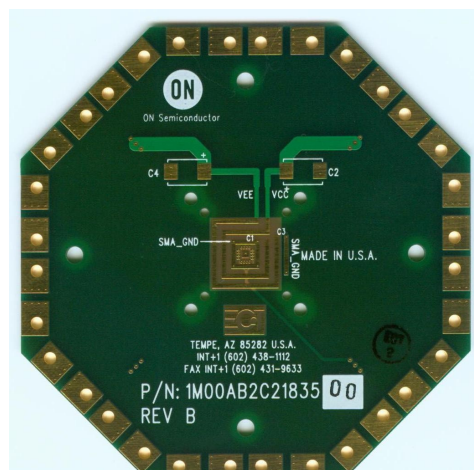

Bottom View

Figure 1. Top and Bottom View of the 16 QFN Evaluation Board



# NB6L72MMNGEVB

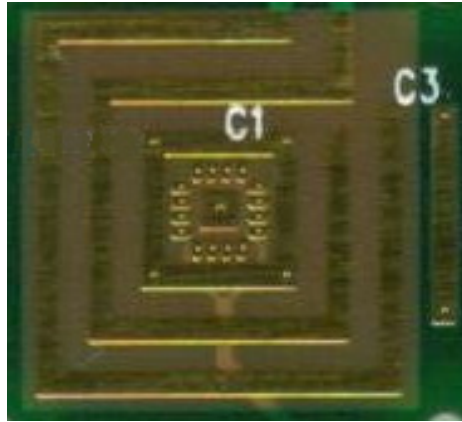

Figure 2. Enlarged Bottom View

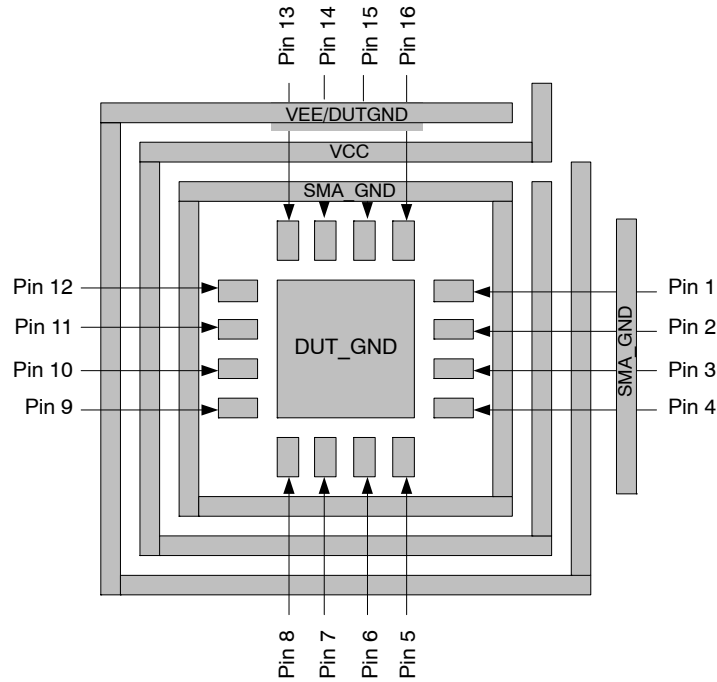

Figure 3. Enlarged Bottom View of the Evaluation Board

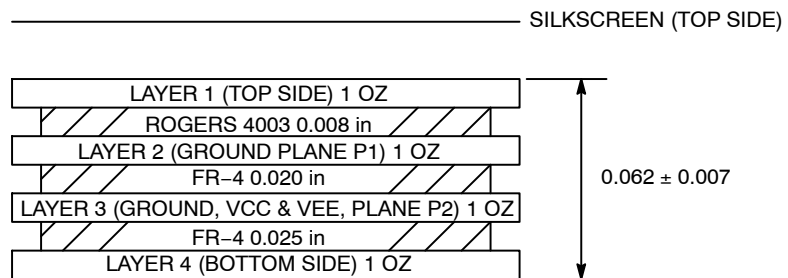

Figure 4. Evaluation Board Layout, 4 Layer

## NB6L72MMNGEVB

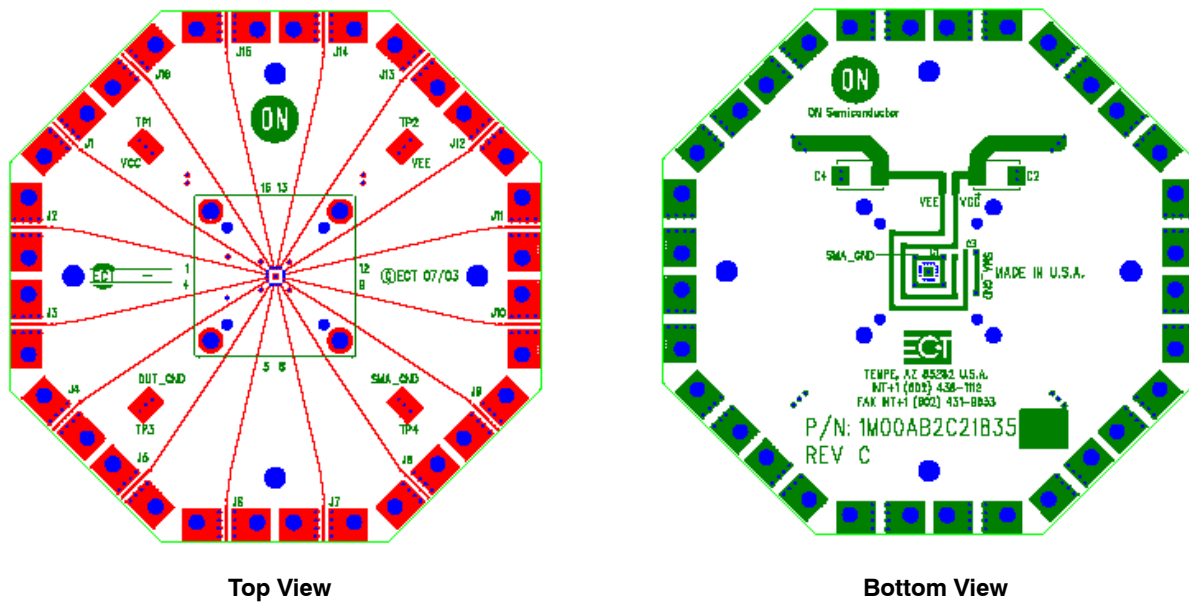

Figure 5. Evaluation Board Layout

### Evaluation Board Assembly Instructions

The QFN-16 evaluation board is designed for characterizing devices in a  $50\ \Omega$  laboratory environment using high bandwidth equipment. Each signal trace on the board has a via at the DUT pin, which provides an option of placing a termination resistor on the board bottom, depending on the input/output configuration (see Table 1, Configuration for Device: NB6L72M). Table 4 contains the Bill of Materials for this evaluation board.

The QFN16EVB was designed to accommodate a custom QFN-16 socket. Therefore, some external components are installed on the bottom side of the board.

### Solder the Device on the Evaluation Board

The soldering of a device to the evaluation board can be accomplished by hand soldering or solder reflow techniques using solder paste. Make sure pin 1 of the device is located properly and all the pins are aligned to the footprint pads. Solder the QFN-16 device to the evaluation board. As mentioned earlier, many QFN16EVBs are dedicated with a device already installed, and can be ordered from onsemi.com at the specific device web page.

### Connecting Power and Ground

On the top side of the evaluation board, solder the four surface mount test point clips (anvils) to the pads labeled  $V_{CC}$ ,  $V_{EE}/DUTGND$ ,  $SMAGND$ , and  $ExPad$ .  $ExPad$  is connected to the exposed flag of the QFN package. For proper operation, the exposed flag is typically recommended to be tied to  $V_{EE}/DUTGND$ , the negative supply of the device.

The positive power supply connector is labeled  $V_{CC}$ . Depending on the device, the negative power supply nomenclature is labeled either  $GND$  or  $V_{EE}$ . To help avoid

confusion with the use of this board, the negative supply connector is labeled  $V_{EE}/DUTGND$ .  $SMAGND$  is the ground for the SMA connectors and is not to be confused with the device ground,  $V_{EE}/DUTGND$ .  $SMAGND$  and  $DUTGND$  can be connected in single-supply applications. The power pin layout and typical connection of the evaluation board is shown in Figure 6.

It is recommended to add bypass capacitors to reduce unwanted noise from the power supplies. Connect  $0.1\ \mu F$  capacitors from  $V_{CC}$  and  $V_{EE}/DUTGND$  to  $SMAGND$ .

### Output Loading/Termination

#### ECL/PECL/LVPECL Outputs

Most ECL outputs are open emitter and need to be DC loaded and AC terminated to  $V_{CC} - 2.0\ V$  via a  $50\ \Omega$  resistor. If no internal resistors are provided on the device, 0402 chip resistor pads are provided on the bottom side of the evaluation board to terminate the ECL driver. Solder the chip resistors to the bottom side of the board between the appropriate input device pads and the ground pads. If internal resistors are provided, the VT pins should be wired to  $SMAGND$ . (More information on termination is provided in AND8020).

For standard ECL lab setup and test, a split (dual) power supply is recommended enabling the  $50\ \Omega$  internal impedance in the oscilloscope, or other measuring instrument, to be used as an ECL output load/termination. By offsetting  $V_{CC} = +2.0\ V$ ,  $SMAGND = V_{CC} - 2.0\ V$ , ( $SMAGND$  is the system ground,  $0V$ );  $V_{CC}$  is  $2.0\ V$ , and  $V_{EE}/DUTGND$  is  $-3.0\ V$ ,  $-1.3\ V$  or  $-0.5\ V$ ; see Table 2, Power Supply Levels).

## NB6L72MMNGEVB

### CML Outputs

Likewise, CML outputs need to be terminated to  $V_{CC}$  via a  $50\ \Omega$  resistor. If no internal resistors are provided on the device, 0402 chip resistor pads are provided on the bottom side of the evaluation board to terminate the CML driver. If internal resistors are provided, the  $V_T$  pins should be wired to  $V_{CC}$ .

For CML lab setup and test, operation with negative supply voltages is recommended to enable the  $50\ \Omega$  internal impedance in the oscilloscope, or other measuring instrument, to be used as a CML output termination; ( $V_{CC} = 0\ \text{V}$ ,  $SMAGND = 0\ \text{V}$ , and  $V_{EE}/DUTGND = -5.0\ \text{V}$ ,  $-3.3\ \text{V}$ ,  $-2.5\ \text{V}$ , or  $-1.8\ \text{V}$ ).

### LVDS Outputs

LVDS outputs are typically terminated with  $100\ \Omega$  across the  $Q/\bar{Q}$  output pair. The  $100\ \Omega$  can be added on the QFN16EVB, but it is not provided on the board, since there are several user dependent LVDS output measurement techniques.

For LVDS lab setup and test, a single supply is typically used, ie.  $V_{CC} = 3.3\ \text{V}$  and  $DUTGND = 0\ \text{V}$ .

### Installing the SMA Connectors

Each configuration indicates the number of SMA connectors needed to populate an evaluation board for a given device. Each input and output requires one SMA connector. Install all the required SMA connectors onto the board and solder the center signal conductor pin to the board on J1 through J16. Please note that the alignment of the signal connector pin of the SMA connector to the metal trace on the board can influence lab results. The launch and reflection of the signals are largely influenced by imperfect alignment and soldering of the SMA connector.

### Validating the Assembled Board

After assembling the evaluation board, it is recommended to perform continuity checks on all soldered areas before commencing with the evaluation process. Time Domain Reflectometry (TDR) is another highly recommended validation test.

# NB6L72MMNGEVB

## NB6L72MMNGEVB ASSEMBLY

**Table 1. CONFIGURATION FOR DEVICE: NB6L72M**

	J1	J2	J3	J4	J5	J6	J7	J8	J9	J10	J11	J12	J13	J14	J15	J16
<b>Device Pin #</b>	1	2	3	4	5	6	7	8	9	10	11	12	13	14	15	16
<b>SMA Connector</b>	Yes	Yes	Yes	Yes	Yes	Yes	Yes	Yes	No	Yes	Yes	No	No	Yes	Yes	No
<b>Wire</b>	No	No	No	No	No	No	No	No	GND	No	No	V <sub>CC</sub>	V <sub>CC</sub>	No	No	GND

NOTE: DUTGND/V<sub>EE</sub> = Exposed Pad and must be tied to DUTGND/V<sub>EE</sub>.

### CONFIGURATIONS

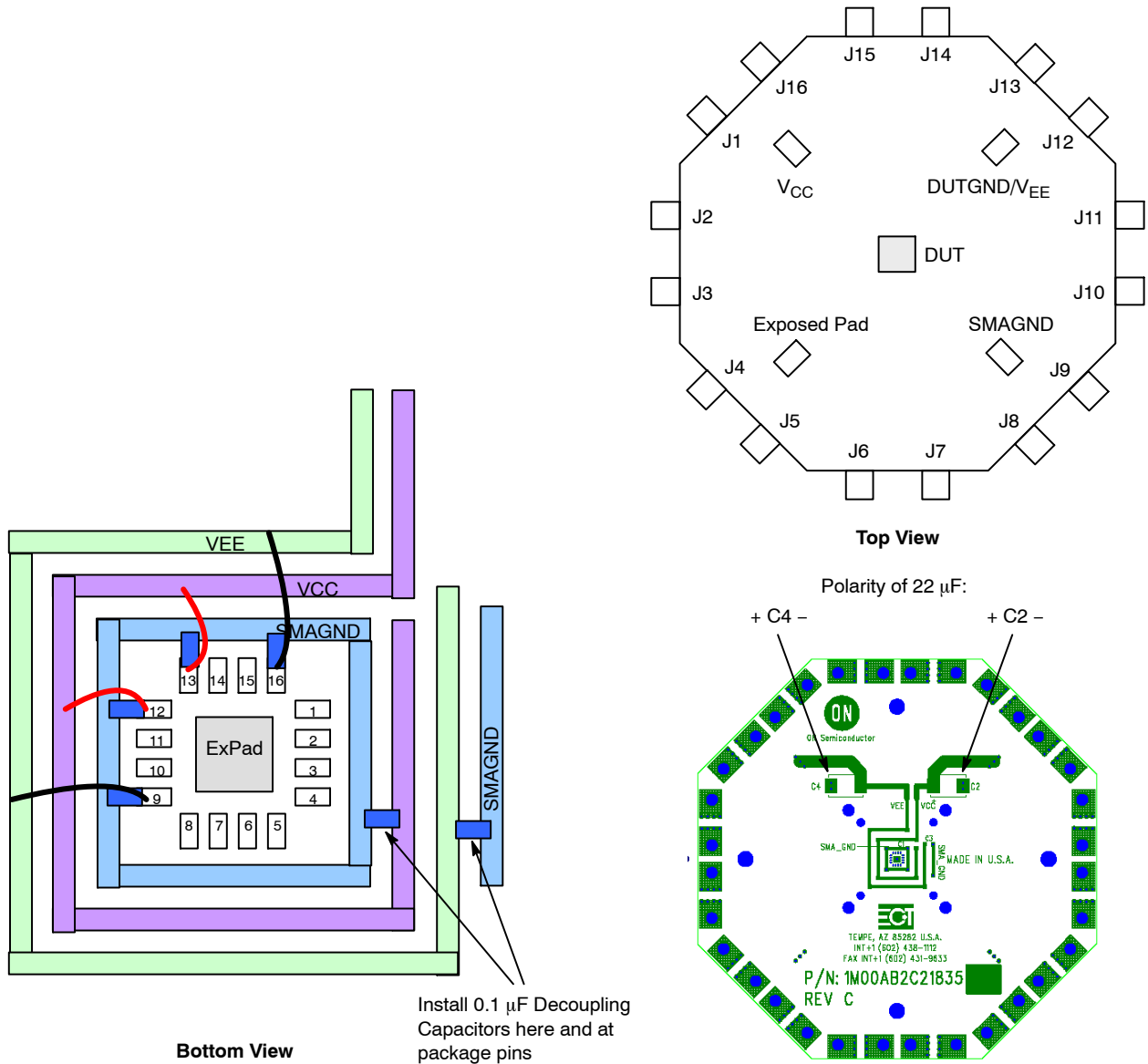

**Figure 6. Power Supply Configuration for Device NB6L72M**

# NB6L72MMNGEVB

## NB6L72MMNGEVB TEST

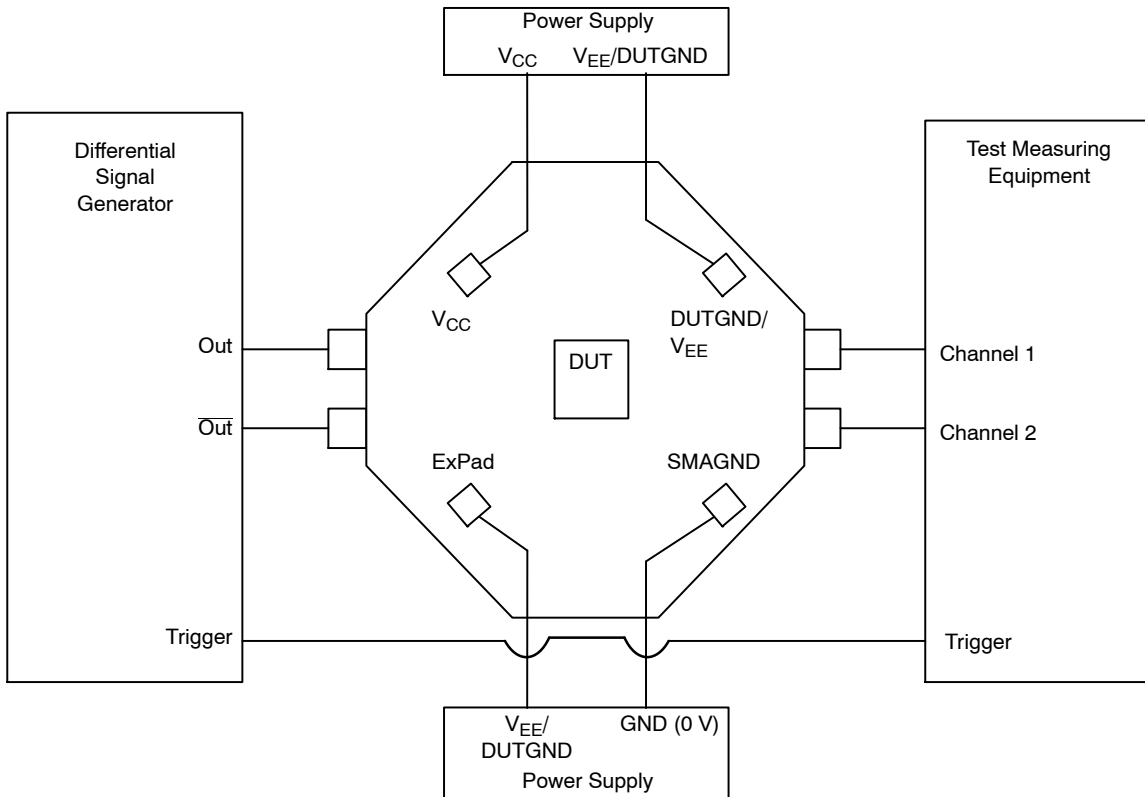

1. Connect appropriate power supplies to  $V_{CC}$ ,  $V_{EE}/DUTGND$ ,  $SMAGND$ , and  $ExPad$  (see Table 2).
2. Connect a signal generator to the input SMA connectors. Setup input signal according to the device data sheet.
3. Connect a test measurement device to the device's output SMA connectors.

NOTE: The test measurement device must contain 50  $\Omega$  termination.

**Figure 7. Basic Lab Setup (Typical)**

**Table 2. POWER SUPPLY LEVELS**

Outputs	Power Supply	$V_{CC}$	$V_{EE}/DUTGND$	$SMAGND$	$ExPad$ (typ)
CML	2.5 V	0 V	-2.5 V	0 V	$V_{EE}/DUTGND$
CML	3.3 V	0 V	-3.3 V	0 V	$V_{EE}/DUTGND$

**Table 3. NB6xxxM, CML OUTPUTS "SPLIT" POWER SUPPLY CONFIGURATION**

Device Pin Power Supply Converter	"Split" Power Supply
$V_{CC}$	$V_{CC} = 0.0$ V
$SMAGND$	$V_{TT} = 0$ V
$DUTGND$	$DUTGND = -2.5$ V or $-3.3$ V

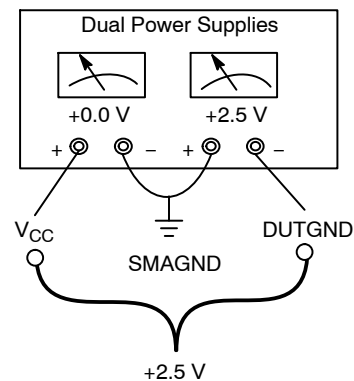

Offset / "Split" Power Supply Configuration

**Figure 8. "Split" or Dual Power Supply Connections**

# NB6L72MMNGEVB

**Table 4. BILL OF MATERIALS**

Components	Manufacturer	Description	Part Number	Qty	Web Site
SMA Connector	Rosenberger	SMA Connector, Side Launch, Gold Plated	32K243-40ME3	12	<a href="http://www.rosenberger.de">http://www.rosenberger.de</a> <a href="http://www.rosenbergerna.com">http://www.rosenbergerna.com</a>
Surface Mount Test Points	Keystone*	SMT Miniature Test Point	5015	4	<a href="http://www.keyelco.com">http://www.keyelco.com</a>
Chip Capacitor	AVC Corporation*	0603 0.01 $\mu$ F $\pm$ 10%	06035C103KAT2A	na	<a href="http://www.avxcorp.com">http://www.avxcorp.com</a>
		0603 0.1 $\mu$ F $\pm$ 10%	0603C104KAT2A	6	
Chip Resistor	Panasonic*	0402 50 $\Omega$ $\pm$ 1% Precision Thick Film Chip Resistor	ERJ-2RKF49R9X	na	<a href="http://www.panasonic.com">http://www.panasonic.com</a>
Evaluation Board	ON Semiconductor	QFN 16 Evaluation Board	QFN16EVB	1	<a href="http://www.onsemi.com">http://www.onsemi.com</a>
Device Samples	ON Semiconductor	QFN 16 Package Device	NB6L72MMNG	1	<a href="http://www.onsemi.com">http://www.onsemi.com</a>

\*Components are available through most distributors, i.e. [www.newark.com](http://www.newark.com), [www.digikey.com](http://www.digikey.com)



# NB6L72MMNGEVB

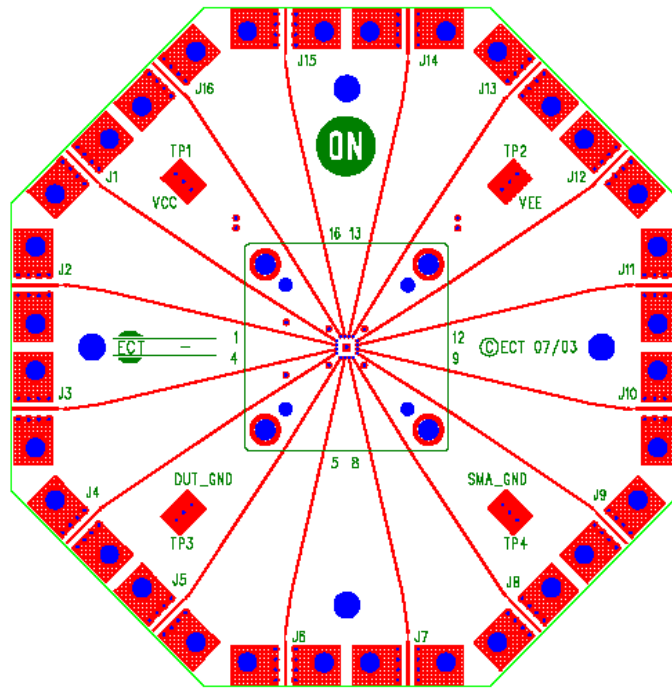

Top Layer

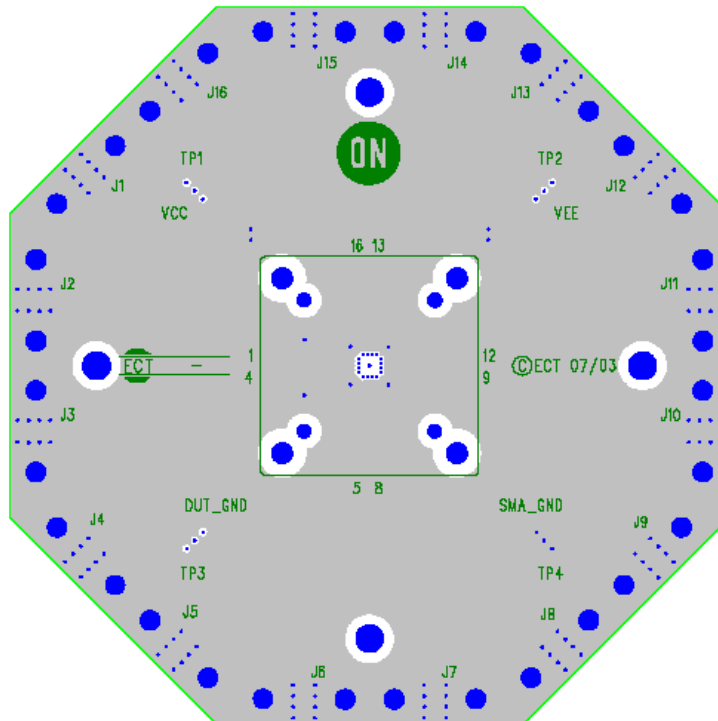

Second Layer (SMA\_GND Plane)

Figure 9. Gerber Files

# NB6L72MMNGEVB

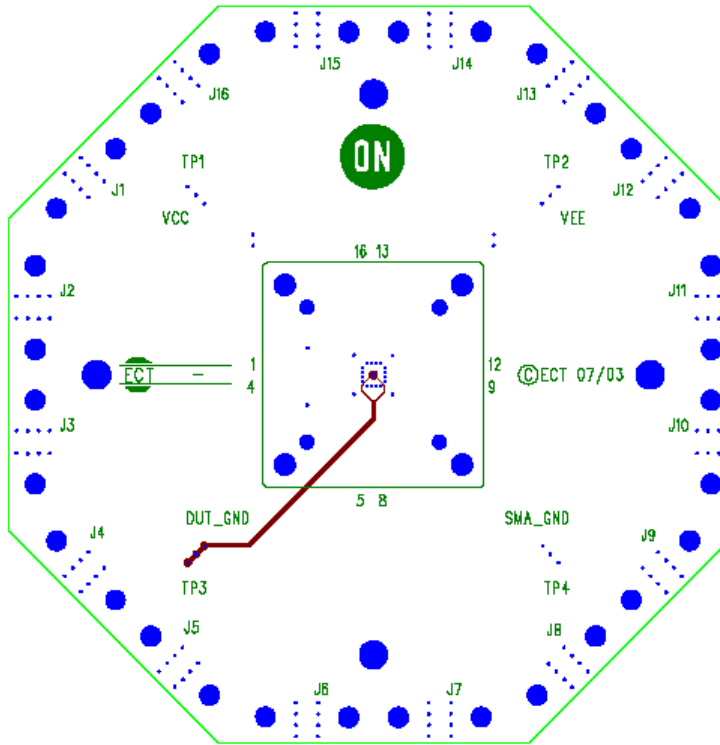

Third Layer (DUT\_GND Trace)

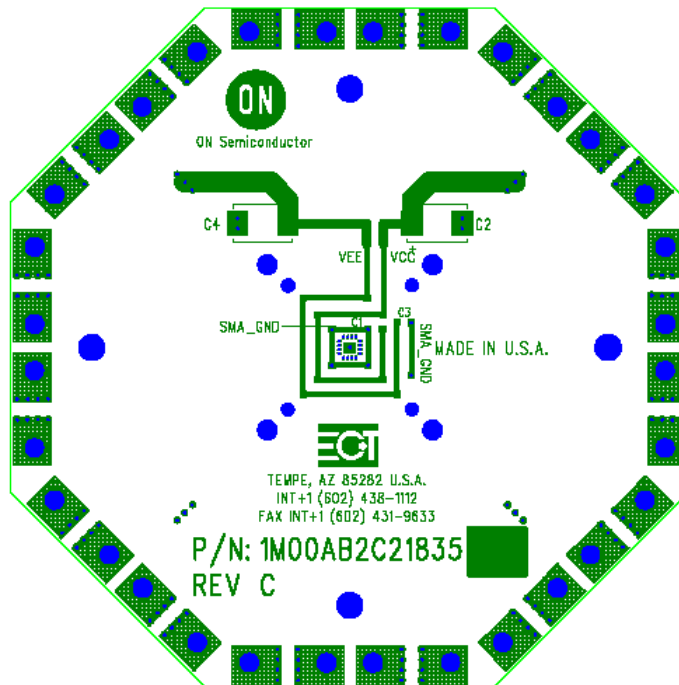

Bottom Layer

Figure 10. Gerber Files

**ON Semiconductor** and  are registered trademarks of Semiconductor Components Industries, LLC (SCILLC). SCILLC owns the rights to a number of patents, trademarks, copyrights, trade secrets, and other intellectual property. A listing of SCILLC's product/patent coverage may be accessed at [www.onsemi.com/site/pdf/Patent-Marking.pdf](http://www.onsemi.com/site/pdf/Patent-Marking.pdf). SCILLC reserves the right to make changes without further notice to any products herein. SCILLC makes no warranty, representation or guarantee regarding the suitability of its products for any particular purpose, nor does SCILLC assume any liability arising out of the application or use of any product or circuit, and specifically disclaims any and all liability, including without limitation special, consequential or incidental damages. "Typical" parameters which may be provided in SCILLC data sheets and/or specifications can and do vary in different applications and actual performance may vary over time. All operating parameters, including "Typicals" must be validated for each customer application by customer's technical experts. SCILLC does not convey any license under its patent rights nor the rights of others. SCILLC products are not designed, intended, or authorized for use as components in systems intended for surgical implant into the body, or other applications intended to support or sustain life, or for any other application in which the failure of the SCILLC product could create a situation where personal injury or death may occur. Should Buyer purchase or use SCILLC products for any such unintended or unauthorized application, Buyer shall indemnify and hold SCILLC and its officers, employees, subsidiaries, affiliates, and distributors harmless against all claims, costs, damages, and expenses, and reasonable attorney fees arising out of, directly or indirectly, any claim of personal injury or death associated with such unintended or unauthorized use, even if such claim alleges that SCILLC was negligent regarding the design or manufacture of the part. SCILLC is an Equal Opportunity/Affirmative Action Employer. This literature is subject to all applicable copyright laws and is not for resale in any manner.

## PUBLICATION ORDERING INFORMATION

### LITERATURE FULFILLMENT:

Literature Distribution Center for ON Semiconductor  
P.O. Box 5163, Denver, Colorado 80217 USA  
**Phone:** 303-675-2175 or 800-344-3860 Toll Free USA/Canada  
**Fax:** 303-675-2176 or 800-344-3867 Toll Free USA/Canada  
**Email:** [orderlit@onsemi.com](mailto:orderlit@onsemi.com)

**N. American Technical Support:** 800-282-9855 Toll Free  
USA/Canada  
**Europe, Middle East and Africa Technical Support:**  
Phone: 421 33 790 2910  
**Japan Customer Focus Center**  
Phone: 81-3-5817-1050

**ON Semiconductor Website:** [www.onsemi.com](http://www.onsemi.com)

**Order Literature:** <http://www.onsemi.com/orderlit>

For additional information, please contact your local  
Sales Representative