



Chipsmall Limited consists of a professional team with an average of over 10 year of expertise in the distribution of electronic components. Based in Hongkong, we have already established firm and mutual-benefit business relationships with customers from,Europe,America and south Asia,supplying obsolete and hard-to-find components to meet their specific needs.

With the principle of “Quality Parts,Customers Priority,Honest Operation,and Considerate Service”,our business mainly focus on the distribution of electronic components. Line cards we deal with include Microchip,ALPS,ROHM,Xilinx,Pulse,ON,Everlight and Freescale. Main products comprise IC,Modules,Potentiometer,IC Socket,Relay,Connector.Our parts cover such applications as commercial,industrial, and automotives areas.

We are looking forward to setting up business relationship with you and hope to provide you with the best service and solution. Let us make a better world for our industry!



Contact us

Tel: +86-755-8981 8866 Fax: +86-755-8427 6832

Email & Skype: info@chipsmall.com Web: www.chipsmall.com

Address: A1208, Overseas Decoration Building, #122 Zhenhua RD., Futian, Shenzhen, China





NXP remote keyless entry transponder combo IC NCF2960

Compact, single-chip solution for remote keyless entry

Delivering rugged performance in a very small (4 x 4 mm) footprint, this highly integrated solution maximizes design freedom and is ideal for advanced Combo-Key applications. Special features of the integrated RF transmitter support frequency hopping and ensure reliable operation even in RF-jammed environments.

Key features

- ▶ Single-chip security transponder and keyless entry solution
- ▶ 16-bit Harvard architecture
- ▶ On-chip UHF transmitter (315 / 434 / 868 / 915 MHz band)
- ▶ Transponder emulation based on HT3, HT-AES, or HT-Pro 2
- ▶ Calculation unit supporting HT3 (96-bit) and AES (128-bit)
- ▶ 16 KB user EROM for application
- ▶ 2 KB ultra-low-power EEPROM
- ▶ 1 KB RAM
- ▶ Up to eight command buttons with wake-up function
- ▶ I/O with current source for direct LED drive
- ▶ Stabilized RF output power
- ▶ Temperature sensor
- ▶ Single lithium cell operation (2.1 to 3.6 V)
- ▶ C-compiler supported software development
- ▶ HVQFN24 (4 x 4 mm) with wettable flanks

Applications

- ▶ Combo-Key applications that combine remote keyless entry with vehicle immobilization

The NXP NCF2960 is a second-generation Combo-key solution that combines a transponder, a microcontroller, and a radio transmitter in a tiny (4 x 4 mm) footprint.

The basic transponder operation is compatible with NXP's security transponder families, including HT3, HT-AES, and HT-Pro2. Custom transponder functions can be implemented using the ROM library of the device by the application.

The transponder circuitry is powered from the LF field and does not require a device battery supply. As a result, full operation is possible even when the battery is low.

The RISC controller uses NXP's third-generation Micro RISC Kernel (MRK III), a low-power implementation that features a 16-bit architecture and executes instructions in a single machine clock cycle.



The on-chip UHF transmitter requires only a single 27.6 MHz reference crystal and loop antenna matching circuitry to operate in one of the following bandwidths: 315 / 434 / 868 / 915 MHz bands. The RF multi-channel capability enables frequency hopping and ensures reliable operation in RF-jammed environments.

There are up to eight I/O ports, with one designed for use with a dedicated LED driver port, and up to eight inputs for command buttons. There is a temperature sensor for battery management and an on-chip pseudo-random number (PRN) generator for use with security protocols.

A fractional-N PLL allows compensation for initial XTL tolerance. The device includes 2 KB of ultra-low-power serial EEPROM

memory (with access control defined by the application), 1 KB of RAM, and up to 16 KB of Flash-like EROM for the application code. The keyless entry code can be generated by the built-in, hardwired calculation unit or by a software-based algorithm.

The device is housed in a tiny 24-pin HVQFN package that consumes only 16 mm² of board space, so it enables ultra-compact designs with maximum freedom for key styling. Wettable package flanks allow optical soldering inspection without an x-ray.

The Flash-like EROM of the device supports in-circuitry programming and debugging of the application code.

NCF2960 application diagram

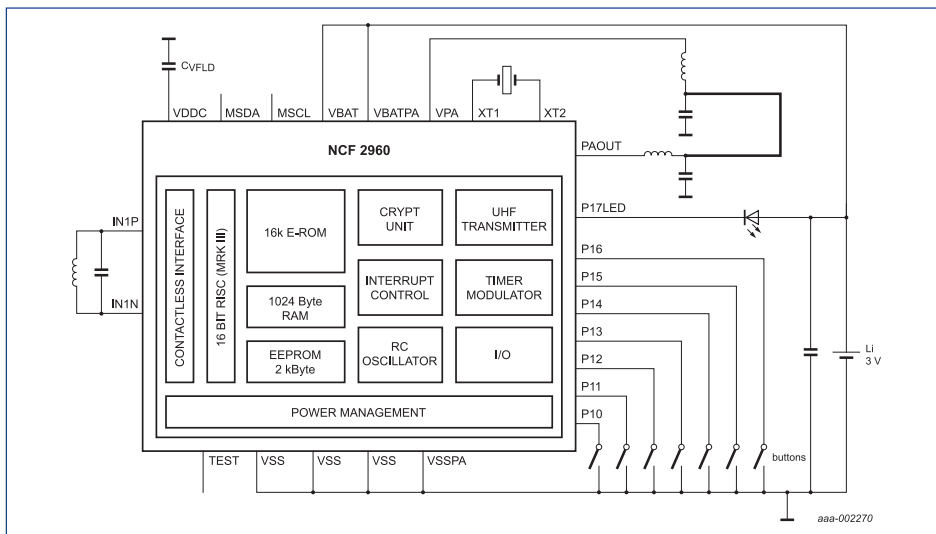

24-pin HVQFN package (4 x 4 mm)



NCF2960 demo board

