



Chipsmall Limited consists of a professional team with an average of over 10 year of expertise in the distribution of electronic components. Based in Hongkong, we have already established firm and mutual-benefit business relationships with customers from,Europe,America and south Asia,supplying obsolete and hard-to-find components to meet their specific needs.

With the principle of “Quality Parts,Customers Priority,Honest Operation,and Considerate Service”,our business mainly focus on the distribution of electronic components. Line cards we deal with include Microchip,ALPS,ROHM,Xilinx,Pulse,ON,Everlight and Freescale. Main products comprise IC,Modules,Potentiometer,IC Socket,Relay,Connector.Our parts cover such applications as commercial,industrial, and automotives areas.

We are looking forward to setting up business relationship with you and hope to provide you with the best service and solution. Let us make a better world for our industry!



Contact us

Tel: +86-755-8981 8866 Fax: +86-755-8427 6832

Email & Skype: info@chipsmall.com Web: www.chipsmall.com

Address: A1208, Overseas Decoration Building, #122 Zhenhua RD., Futian, Shenzhen, China





Test Procedure for the NCL30000LED3GEVB 90-305 Vac Extended full range LED Driver Evaluation Board

Introduction:

The NCL30000LED3GEVB Evaluation Board is an extended range universal input (90-305Vac), isolated high power factor single-stage off-line power supply intended to provide a constant current output for powering high brightness LEDs. The output has over current, over temperature, and open load protection. The evaluation board is configured to provide a nominal current of 350 mA with an open LED clamp voltage of ~56V. The switching topology is a critical conduction mode (CrM) flyback converter.

Test Equipment Required:

1. Adjustable, isolated AC power source capable of zero to 305 Vac output at up to 500mA. AC source should have the capability of measuring delivered power in watts and power factor. If not, an AC line analyzer or AC wattmeter should be used.
2. Digital volt/amp meters to measure output current and voltage to the electronic load.
3. A variable electronic load or rheostat capable of up to 20 watts and at least 60 volts. If an electronic load is used it must have a constant resistance mode.
4. Oscilloscope with probe to monitor output ripple on the demo converter.

Setup Procedure:

Set the equipment as shown in the diagram on the next page so the input and output voltage and current of the evaluation board can be measured. The oscilloscope should be set up so that the output ripple can be monitored.

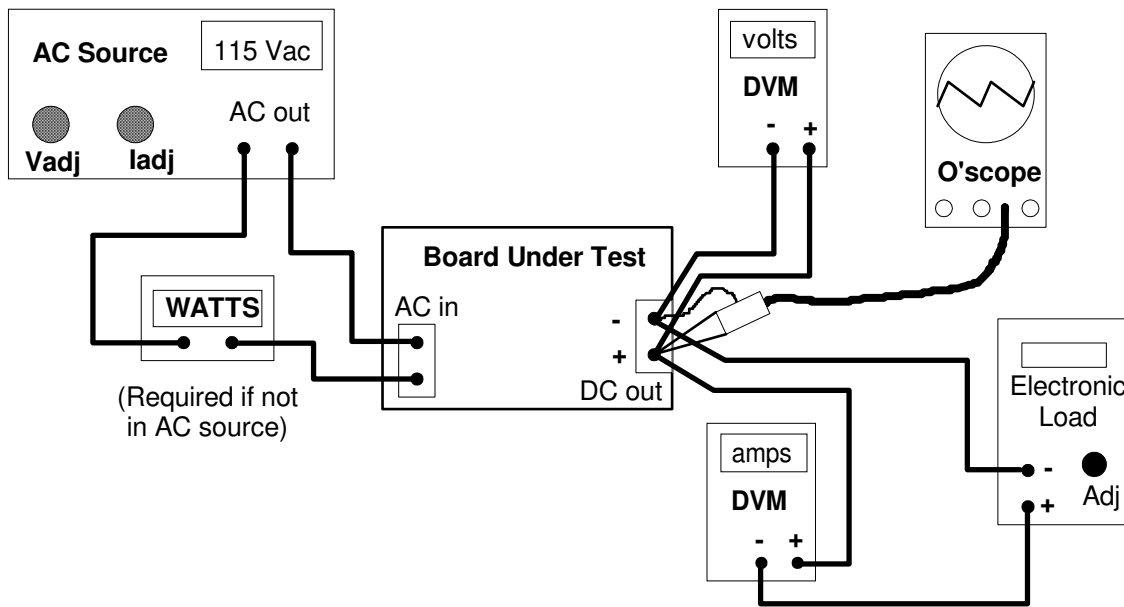

Test Procedure:

1. Connect UUT (Unit Under Test) to the test setup. Switch the electronic load on, set to constant resistance mode and the load adjust to high resistance/zero load; switch all of the digital meters on (assuming they are wired properly for voltage and current sensing); turn the oscilloscope on with sensing in AC mode and 200 mV per division vertical and a sweep rate of 5 mS per division. Connect the scope probe to the demo board's output terminals.
2. With the AC source OFF, set the current limit on the AC source to 500 mA and the output voltage to 115 Vac.
3. Turn on the AC source. At no load, the power supply demo board output voltage should be between 54 and 58 volts on the DVM.
4. Adjust the electronic load from no load slowly up until the output voltage reduces to between 36.5 and 37.5 volts. The output current should be within the range of 332 to 368 mA. Record the measured load current for future reference. Input power should be less than 16.8 watts. Figure 1 shows a typical voltage/current regulation curve for this driver operating at 115 Vac input. The output ripple on the oscilloscope should be less than 1.5 V peak-to-peak including spikes.
5. Increase the load slowly and the current should remain constant within +/- 5 mA of the recorded value as voltage reduces with increased load (constant current output characteristic.) The current should remain within +/-5 mA of the value measured in step 4 above from 50 volts down to about 11 volts output. Adjust the electronic load back to 36.5 to 37.5 volts.
6. Reduce the AC input to 90 Vac and verify current is within +/- 5 mA of the value recorded in step 4 above.



7. Slowly increase the AC input to 305 Vac while monitoring output current. Current should remain within +/- 5 mA of the recorded value after dwelling a minimum of 1 second at any input voltage within the range of 90 to 305 Vac.
8. Turn the AC source off and disconnect UUT from test set.
9. Use a permanent marking pen to place a small ink dot on the white rectangles located on the PCB silkscreen. On the top side mark box “350” and on bottom side mark “90-305V”

End of Test.

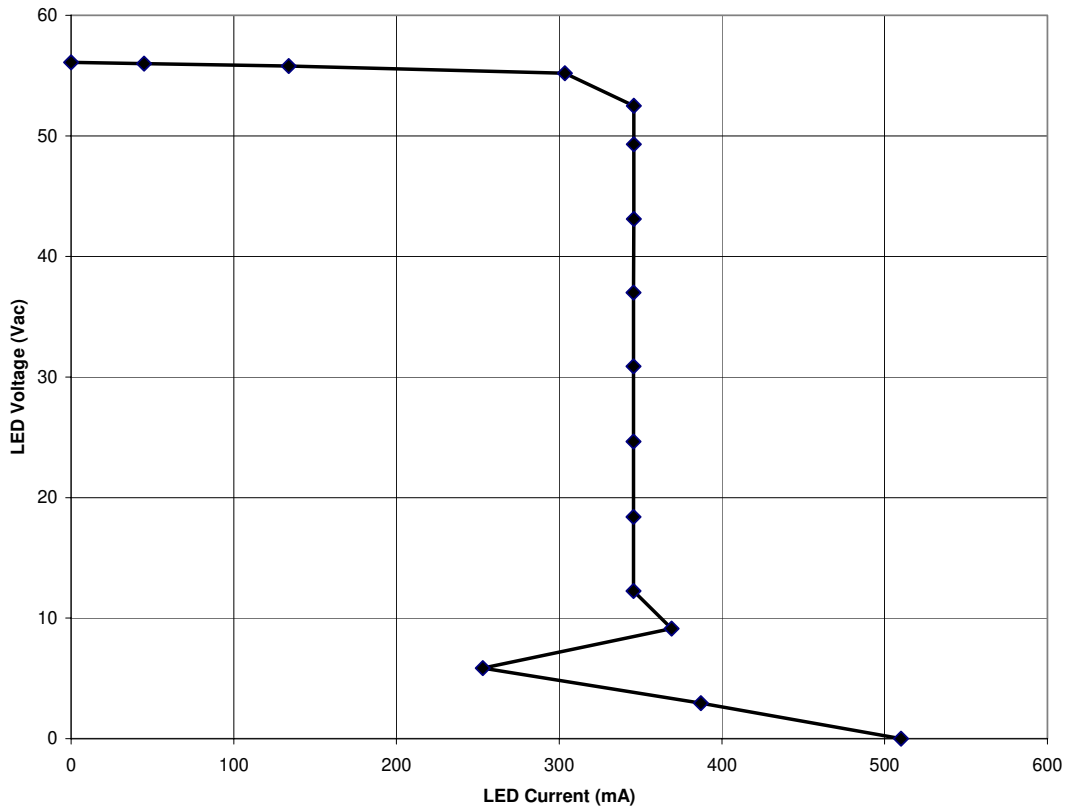

Figure 1