



Chipsmall Limited consists of a professional team with an average of over 10 year of expertise in the distribution of electronic components. Based in Hongkong, we have already established firm and mutual-benefit business relationships with customers from,Europe,America and south Asia,supplying obsolete and hard-to-find components to meet their specific needs.

With the principle of “Quality Parts,Customers Priority,Honest Operation,and Considerate Service”,our business mainly focus on the distribution of electronic components. Line cards we deal with include Microchip,ALPS,ROHM,Xilinx,Pulse,ON,Everlight and Freescale. Main products comprise IC,Modules,Potentiometer,IC Socket,Relay,Connector.Our parts cover such applications as commercial,industrial, and automotives areas.

We are looking forward to setting up business relationship with you and hope to provide you with the best service and solution. Let us make a better world for our industry!



Contact us

Tel: +86-755-8981 8866 Fax: +86-755-8427 6832

Email & Skype: info@chipsmall.com Web: www.chipsmall.com

Address: A1208, Overseas Decoration Building, #122 Zhenhua RD., Futian, Shenzhen, China





NCL30086SMRTGEVB 8 W Smart LED Driver Evaluation Board User's Manual

ON Semiconductor®

www.onsemi.com

Overview

This manual covers the specification, theory of operation, testing and construction of the NCL30086SMRTGEVB demonstration board. The NCL30086 board demonstrates an 8 W high PF SEPIC LED driver with a 3.3 V ‘always on’ auxiliary voltage rail to power a MCU/wireless transceiver plus other accessories. A simple dimming and ON/OFF control is also provided that demonstrates dimming control of the NCL30086 as well as dim to off operation.

EVAL BOARD USER'S MANUAL

Specifications

Input voltage (Class 2 Input, No Ground)	100 – 265 V ac	
Line Frequency	50 Hz/60 Hz	
Power Factor (100% Load)	0.9	Min.
IEC61000–3–2 Class C	Yes	
LED Output Voltage Range	40 – 80 V dc	
LED Output Current	100 mA dc	Typ.
Aux. Voltage (Available in All Modes)	3.3 – 3.5 V	
Aux. Current (User Adjustable)	20 mA	Max.
Efficiency	84%	Typ.
Standby Power 230 V 50 Hz 120 V 60 Hz	400 mW Universal Mains or 170 mW 230 V Optimized 170 mW	Typ.
Analog Dimming Voltage 100% Output 0% Output	$V_{DIM} > 2.5 V$ $V_{DIM} < 0.1 V$	
PWM Dimming Voltage	0 – 3.3 V	
PWM Range (Freq > 200 Hz)	0 – 100%	
Start Up Time	< 500 ms	Typ.
EMI (Conducted)	Class B	FCC/CISPR

Key Features

- Wide Mains
- IEC61000–3–2 Class C Compliance over Line and Load
- High Power Factor across Wide Line and Load
- Integrated Auto Recovery Fault Protection (Can be Latched by Choice of Options)
 - ◆ Over Temperature on Board (a PCB Mounted NTC)
 - ◆ Over Current
 - ◆ Output and V_{CC} Over Voltage
- 3.3V Aux Voltage
 - ◆ Available in All Modes
- “Dim to Zero Output”
- On/Off Control

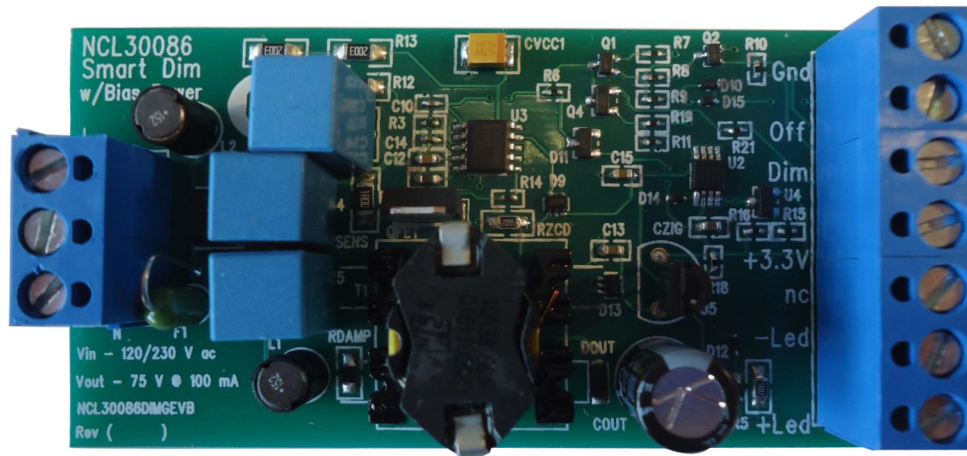

Figure 1. NCL30086SMRTGEVB

THEORY OF OPERATION

Power Stage

The power stage for the demo board is a non-isolated coupled SEPIC converter. The controller has a built in control algorithm that is specific to the flyback transfer function and applies to flyback, buck-boost, and SEPIC converters. Specifically:

$$\frac{V_{OUT}}{V_{IN}} = \frac{Duty}{(1 - Duty)} \quad (eq. 1)$$

The control is very similar to the control of the NCL30080–83 with the addition of a power factor correction control loop. The controller has a built in hardware algorithm that relates the output current to a reference on the primary side.

$$I_{OUT} = \frac{V_{REF} \cdot N_{PS}}{2 \cdot R_{SENSE}} \quad (eq. 2)$$

$$N_{PS} = \frac{N_{PRI}}{N_{SEC}} \quad (eq. 3)$$

Where:

N_{PRI} = Primary Turns

N_{SEC} = Secondary Turns

We can now find R_{SENSE} for a given output current.

$$R_{SENSE} = \frac{V_{REF} \cdot N_{PS}}{2 \cdot I_{OUT}} \quad (eq. 4)$$

Line Feedforward

The controller is designed to precisely regulate output current and can be compensated to address variation due to line voltage variation. R14 sets the line feedforward and compensates for power stage delay times by reducing the current threshold as the line voltage increases. R14 is also used for the shorted CS (current sense) pin detection. At start up, the controller puts out a current to check for a shorted pin.

If R14 was not present, the measured voltage would be too low due to the low value of the current sense resistor and the controller will not start because it will detect a shorted pin. So R14 is required for proper operation and should be greater than 250 Ω .

Voltage Sense

The voltage sense pin has several functions:

1. Basis for the Reference of the PFC Control Loop
2. Line Range Detection

The reference scaling is automatically controller inside the controller. The shape of the voltage waveform on V_S is critical for the PFC loop control. The amplitude of V_S is important for the range detection. Generally, the voltage on V_S should be 3.5 V peak at the highest input voltage of interest. Voltage on V_S must **not** be greater than 4 V under any operating condition. The voltage on V_S determines which valley the power stage will operate in. At low line and maximum load, the power stage operates in the first valley (standard CrM operation). At the higher line range, the power stage moves to the second valley to lower the switching frequency while retaining the advantage of quasi-resonant soft switching.

Auxiliary Winding

The auxiliary winding has 3 functions:

1. CrM Timing
2. V_{CC} Power
3. Output Voltage Sense

CrM Timing

In the off time, the voltage on the transformer/inductor forward biases D_{OUT} and D9. When the current in the magnetic has reached zero, the voltage collapses to zero. This voltage collapse triggers a comparator on the ZCD pin to start a new switching cycle. The ZCD pin also counts rings

on the auxiliary winding for higher order valley operation. A failure of the ZCD pin to reach a certain threshold also indicates a shorted output condition.

V_{CC} Power

The auxiliary winding forward biases D9 to provide power for the controller. This arrangement is called a “bootstrap”. Initially CV_{CC} is charged through R4 and R13. When the voltage on CV_{CC} reaches the startup threshold, the controller starts switching and providing power to the output circuit and the CV_{CC}. CV_{CC} discharges as the controller draws current. As the output voltage rises, the auxiliary winding starts to provide all the power to the controller. Ideally, this happens before CV_{CC} discharges to the under voltage threshold where the controller stops operating to allow CV_{CC} to recharge once again. The size of the output capacitor will have a large effect on the rise of the output voltage. Since the LED driver is a current source, the rise of output voltage is directly dependent on the size of the output capacitor.

There are tradeoffs in the selection of C_{OUT} and CV_{CC}. A low output ripple will require a large C_{OUT} value. This requires that CV_{CC} be large enough to support V_{CC} power to the controller while C_{OUT} is charging up. A large value of CV_{CC} requires that R4 and R13 be lower in value to allow a fast enough startup time. Smaller values of R4 and R13 have higher static power dissipation which lowers the efficiency of the driver. In general for a smart lighting application, startup time may not be as critical given that intent is that the driver IC is always biased even when the lamp is off.

Output Voltage Sense

The auxiliary winding voltage is proportional to the output voltage by the turns ratio of the output winding and the auxiliary winding. The controller has an overvoltage limit on the V_{CC} pin at 25.5 V minimum. Above that threshold, the controller will stop operation and enter overvoltage fault mode. This protection would normally be triggered if the LED string had an open.

In certain cases when the output has significant ripple current and the LED has high dynamic resistance, the peak output voltage can be much higher than the average output voltage. The auxiliary winding will charge the CV_{CC} to the peak of the output voltage which may trigger the OVP sooner than expected so in this case the peak voltage of the LED string is critical. The design of the auxiliary winding turns ratio needs to factor in the absolute peak LED forward voltage.

SD Pin

The SD pin is a multi-function protection input.

1. Thermal Foldback Protection
2. Programmable OVP

Thermal Protection

There is an internal current source from the SD pin. Placing an NTC from the SD pin to ground will allow the designer to choose the level of current foldback protection in the event of high temperature. Output current is reduced when the voltage on the SD pin drops below 1 V.

Below 0.5 V on SD, the controller stops. Addition of series or parallel resistors with the NTC can shape the foldback curve and this can be modeled using the on-line EXCEL[®] design tool. In the event that the pin is left open, there is a soft voltage clamp at 1.35 V (nominal).

While the SD pin has a current source for the OTP, it can be overcome raising the voltage on the SD pin. At about 2.5 V, the SD pin detects an OVP and shuts down the controller. Typically, a zener to V_{CC} is used for this. In this way, the designer can set the OVP to a lower value than the OVP threshold built into the V_{CC} pin. The zener programmable OVP is not implemented on this demo board.

AUX Power Management

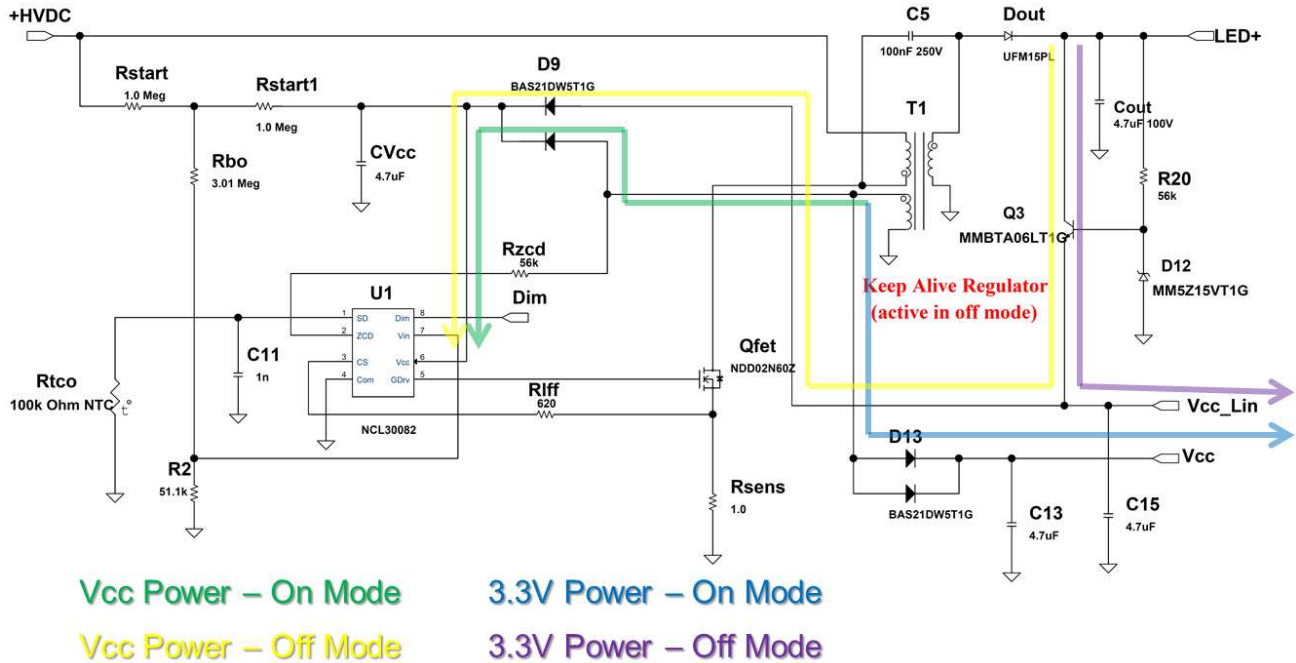

NOTE: While this is shown for the NCL30082 controller, the management scheme is the same for the NCL30086SMRTGEVB demo board.

Figure 2. AUX Power Management

Circuit Modifications

Output Current

The output current is set by the value of R_{SENSE} as shown above. It's possible to adjust the output current by changing R_{SENSE} . Since the magnetic is designed for 8 W, it is possible to increase the current while reducing the maximum LED forward voltage within limits. Changes of current of $\pm 10\%$ are within the existing EMI filter design and magnetic, changes of more than 10% may require further adjustments to the transformer or EMI filter.

Connections

AC Input

1. AC Neutral
2. NC
3. AC Line

Output

1. LED+
2. LED-
3. NC
4. +3.3 V
5. Dim Input
6. On/Off Control
7. Signal Ground

Interface Control Signals

On/Off Control

The on/off control defaults to “on” if left open. Grounding this pin to signal ground turns the output “off”. In “off” mode, the output voltage will regulate to ~ 16 V. This is well below the level that will cause the LEDs to pass current resulting in a true off mode. “Off” mode is also the standby mode. The standby power consumption is greatly affected by the values of R4 and R13. You can see this in Figure 22 for universal mains and 230 V optimized mains. The designer may choose to trade off start up time for standby power consumption. In a “Smart Bulb” application, the mains power is left on so the bulb can be controlled remotely. This designer can choose to optimize standby power by allowing the power on startup time to be longer than 0.5 s since power on timing is now a one-time event. In this case, R4 and R13 are optimized for low power consumption rather than an optimized startup time.

Dim Control

The dim control input will accept either an analog or PWM signal. The output has full range from 0% to 100% output. A 0 volt input to the dim connection causes Q4 to operate in linear mode which maintains the voltage on the dim pin of the controller at its minimum level. At 0 volts on the dim connection, the output voltage will be ~ 25 V which is below the forward voltage of the LEDs.

SCHEMATIC

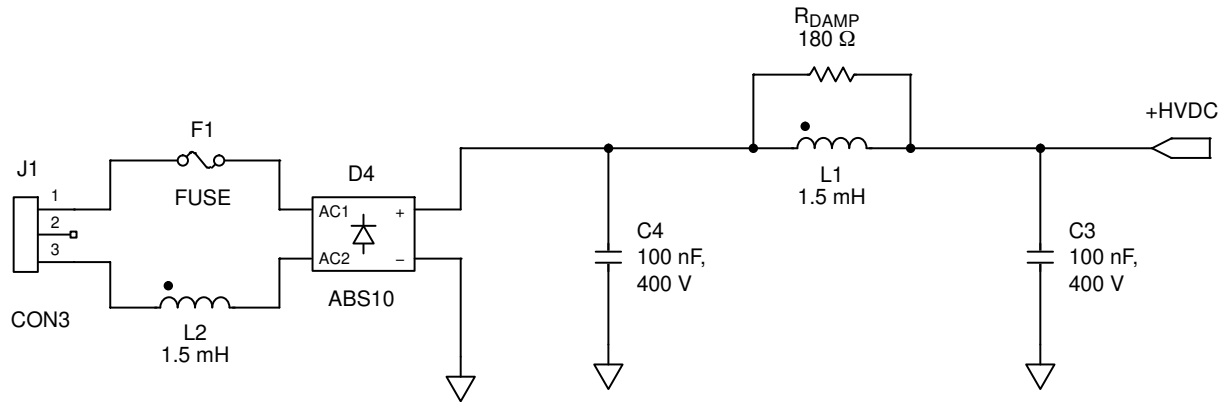

Figure 3. Input Circuit

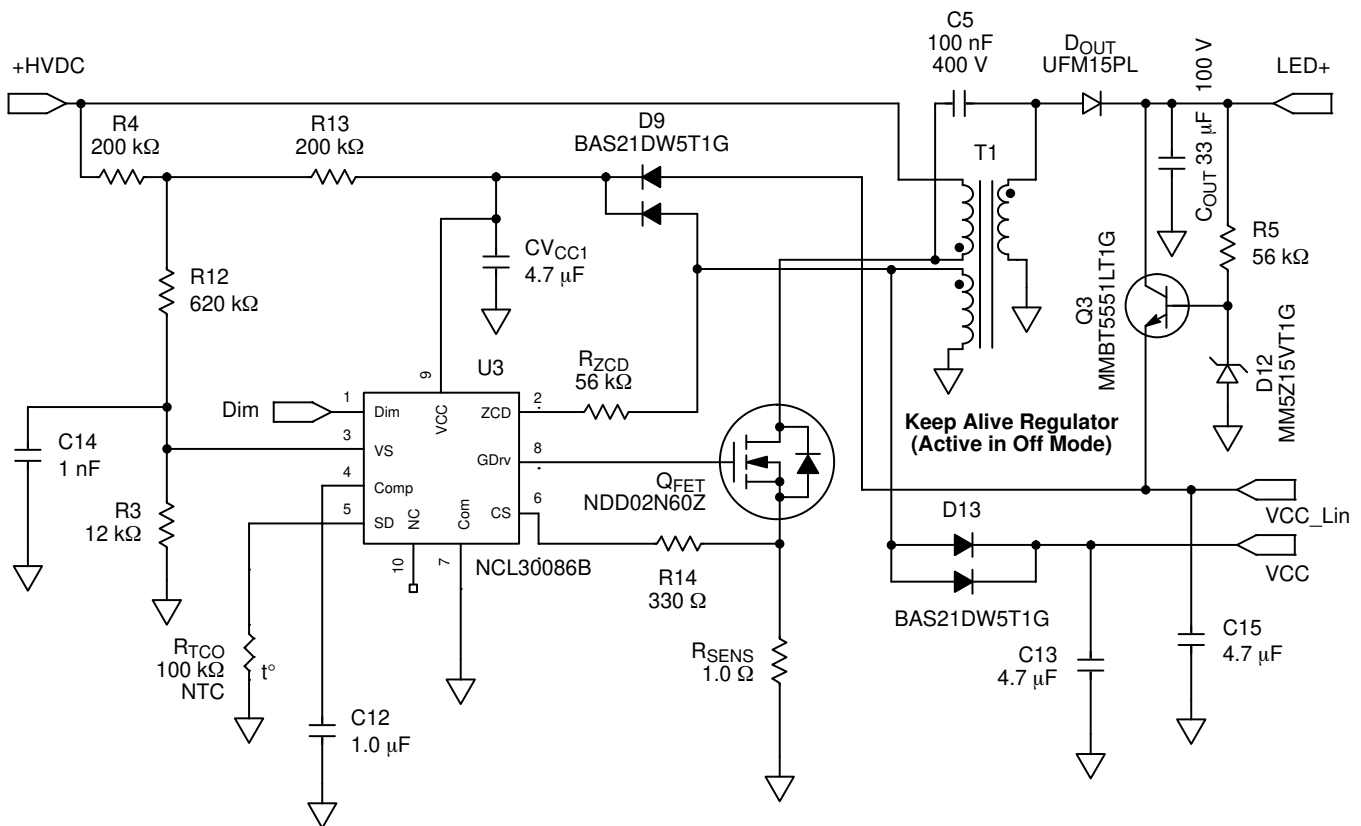

Figure 4. Main Schematic

Available “3.3 V” Power

In active mode, the current source (U5) and shunt (U4) represent a constant power load to the LED driver to ensure consistent LED current regulation regardless of the instantaneous demand on the 3.3 V output from the MCU/wireless transceiver plus other accessories. NCP431A was selected for the shunt regulator due to its low

quiescent current. For very low current draw on the 3.3 V aux output, U5 may not be needed. Variable loads on the 3.3 V aux output may result in flicker of the LED without the stabilization from U5.

The design is setup for 20 mA, adjusting the value of R18 can raise or lower available current based on the specific application needs.

Figure 5. Interface Schematic

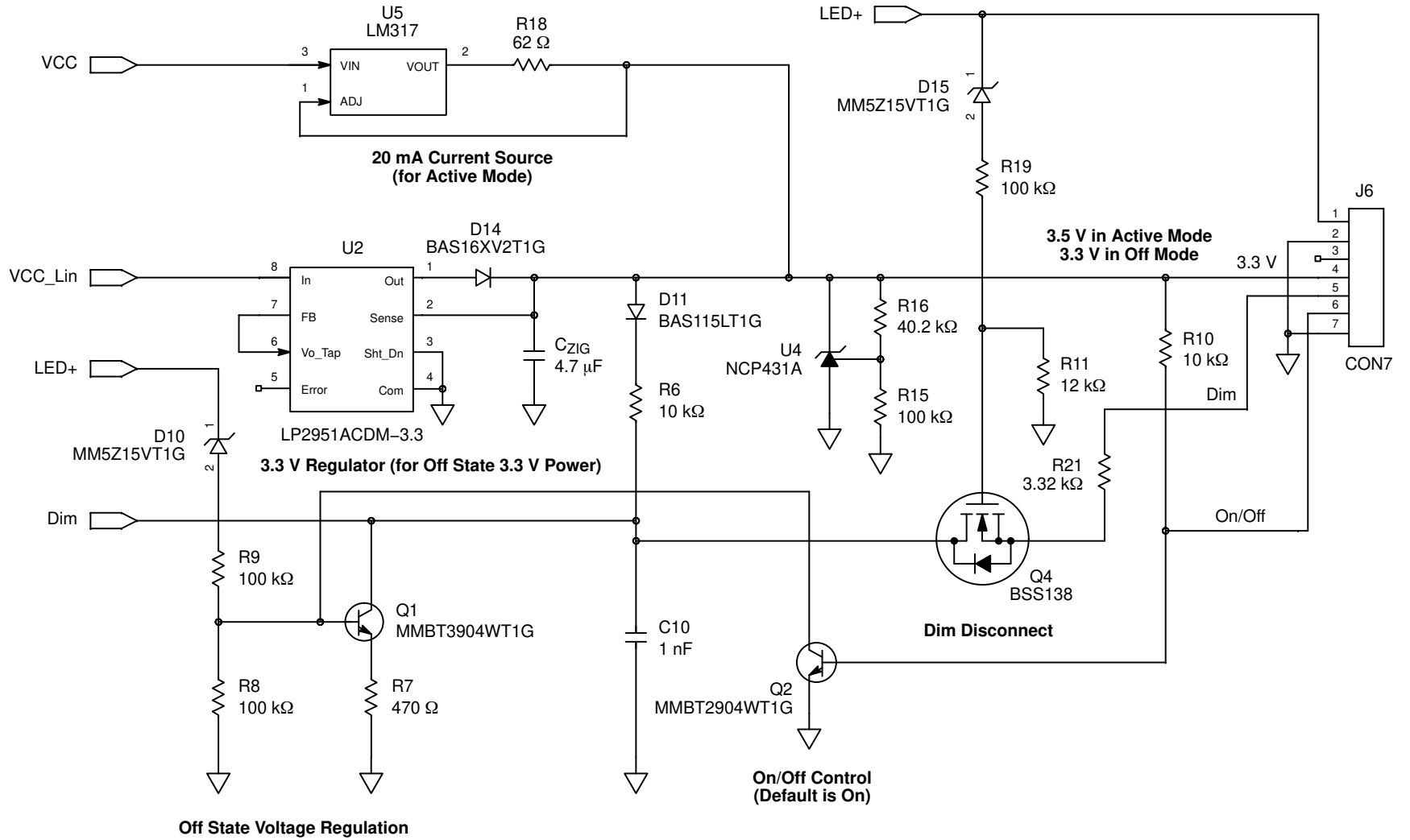

EVBUM2293/D

GERBER VIEWS

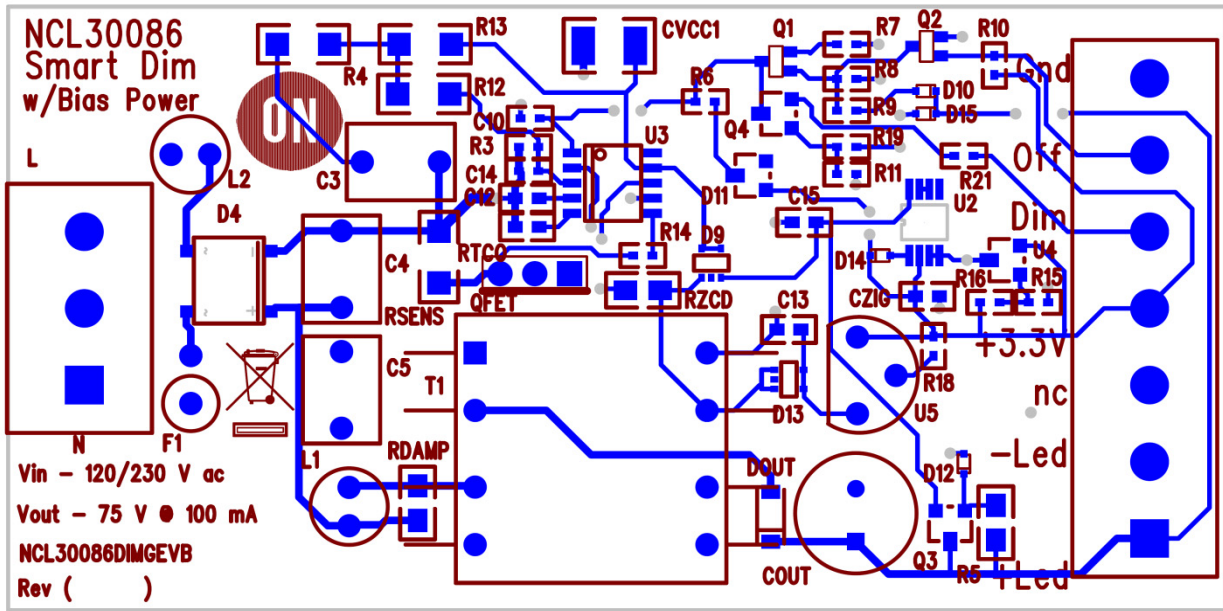

Figure 6. Top Side PCB

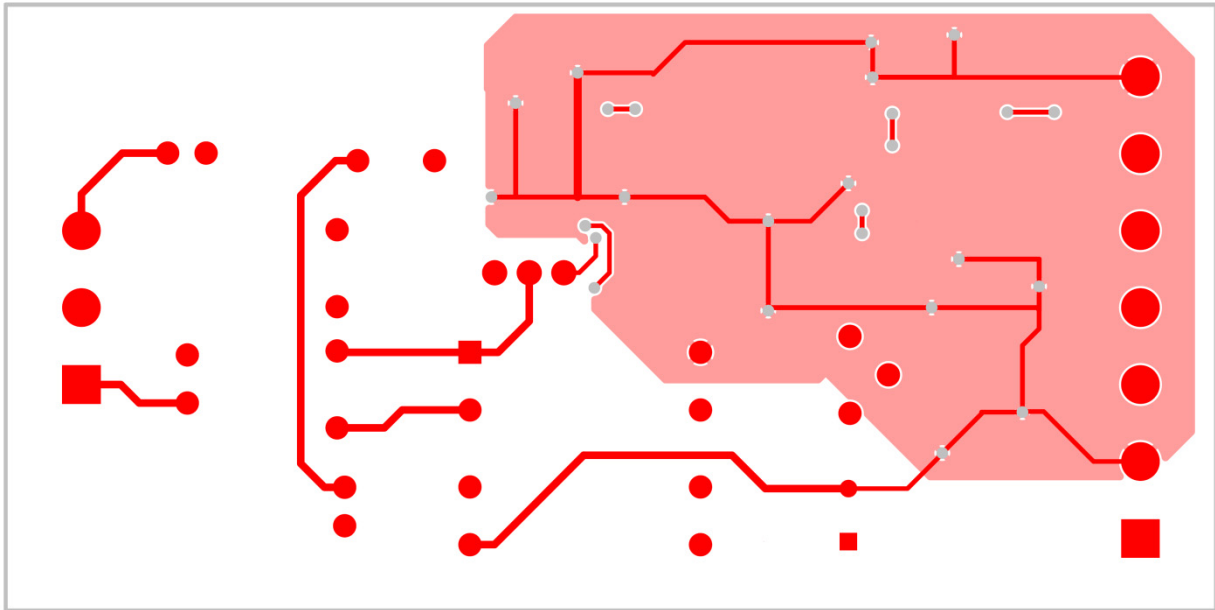

Figure 7. Bottom Side PCB

EVBUM2293/D

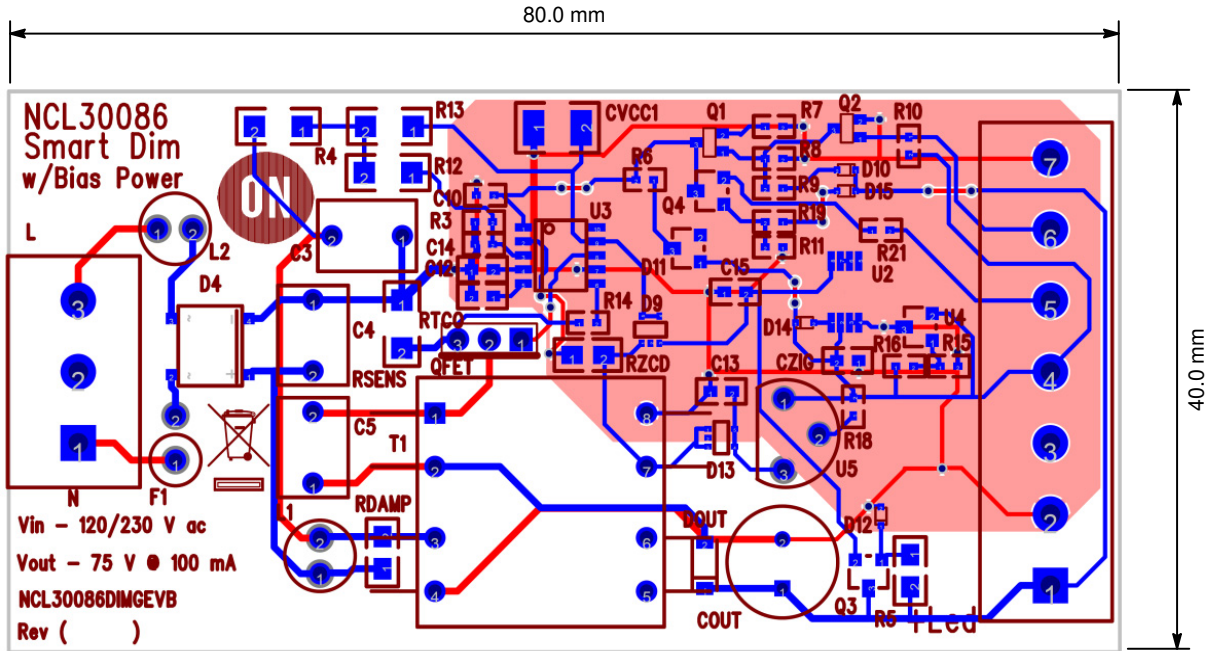

Figure 8. PCB Outline

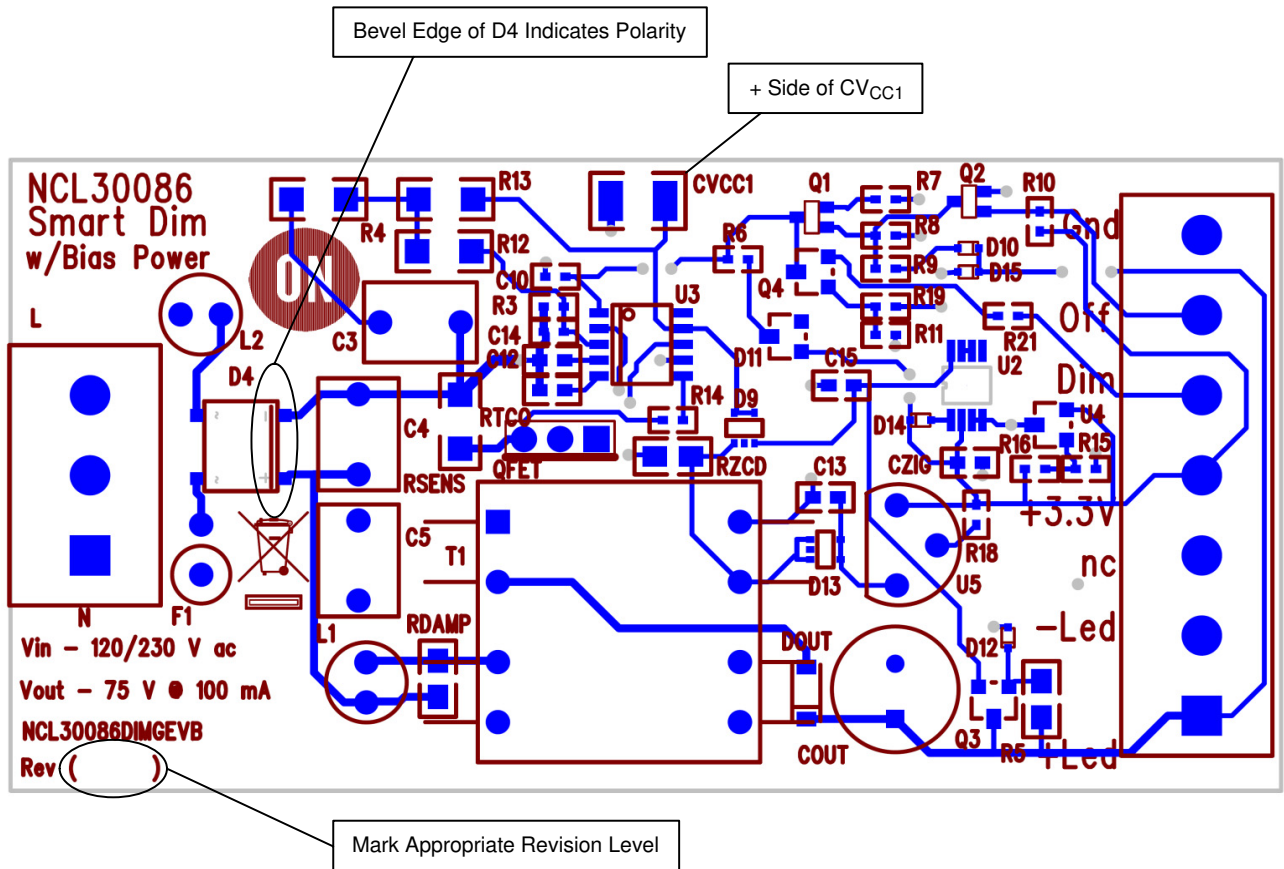

Figure 9. Assembly Notes

EVBUM2293/D

CIRCUIT BOARD FABRICATION NOTES

1. Fabricate per IPC-6011 and IPC6012. Inspect to IPA-A-600 Class 2 or updated standard.
2. Printed Circuit Board is defined by files listed in fileset.
3. Modification to copper within the PCB outline is not allowed without permission, except where noted otherwise. The manufacturer may make adjustments to compensate for manufacturing process, but the final PCB is required to reflect the associated gerber file design ± 0.001 in. for etched features within the PCB outline.
4. Material in accordance with IPC-4101/21, FR4, Tg 125°C min.
5. Layer to layer registration shall not exceed ± 0.004 in.
6. External finished copper conductor thickness shall be 0.0026 in. min. (ie 2oz)
7. Copper plating thickness for through holes shall be 0.0013 in. min. (ie 1oz)
8. All holes sizes are finished hole size.
9. Finished PCB thickness 0.062 in.
10. All un-dimensioned holes to be drilled using the NC drill data.
11. Size tolerance of plated holes: ± 0.003 in.; non-plated holes ± 0.002 in.
12. All holes shall be ± 0.003 in. of their true position U.D.S.
13. Construction to be SMOBC, using liquid photo image (LPI) solder mask in accordance with IPC-SM-B40C, Type B, Class 2, and be green in color.
14. Solder mask mis-registration ± 0.004 in. max.
15. Silkscreen shall be permanent non-conductive white ink.
16. The fabrication process shall be UL approved and the PCB shall have a flammability rating of UL94V0 to be marked on the solder side in silkscreen with date, manufactures approved logo, and type designation.
17. Warp and twist of the PCB shall not exceed 0.0075 in. per in.
18. 100% electrical verification required.
19. Surface finish: electroless nickel immersion gold (ENIG)
20. RoHS 2002/95/EC compliance required.

ECA PICTURE

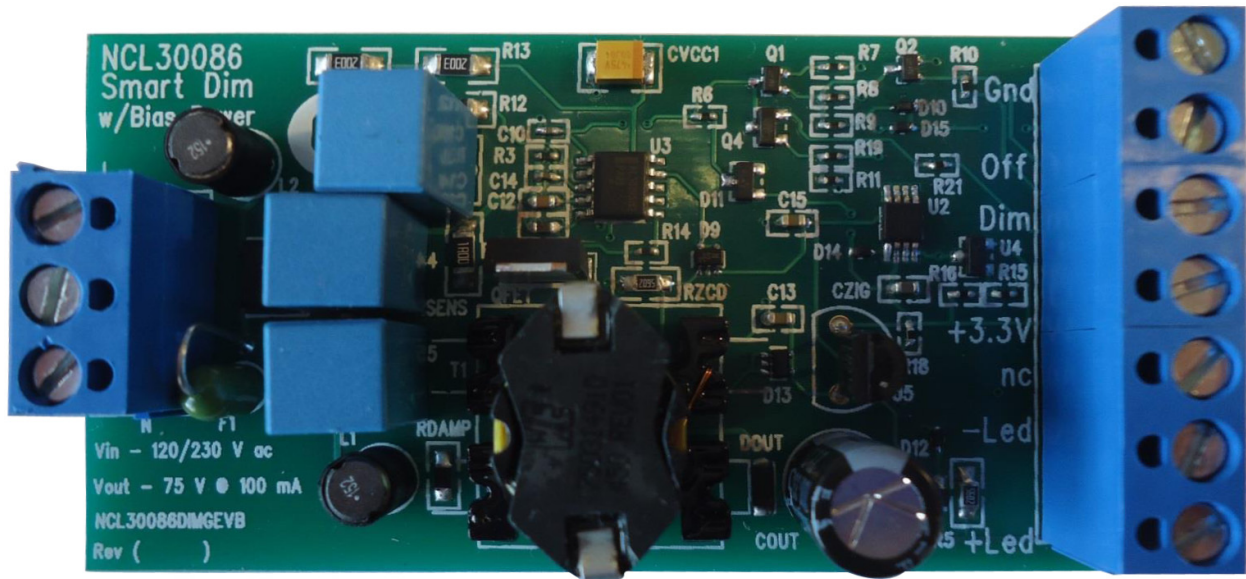

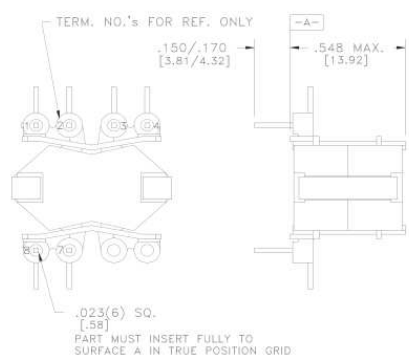

Figure 10. Top View

EVBUM2293/D

SEPIC INDUCTOR SPECIFICATION

CUSTOMER TERMINAL	RoHS	LEAD(Pb)-FREE		
Sn96%, Ag4%	Yes	Yes		



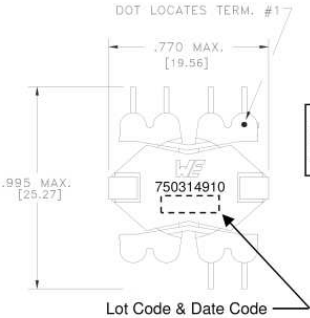

Update bobbin view at release.
LJG 6/20/14

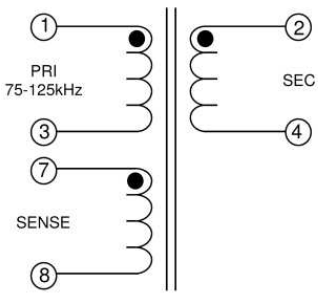

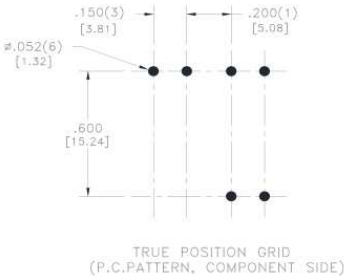

ELECTRICAL SPECIFICATIONS @ 25°C unless otherwise noted:

D.C. RESISTANCE (@20°C):	1-3, 0.890 Ohms ±10%. 2-4, 0.835 Ohms ±10%. 7-8, 0.236 Ohms ±10%.
DIELECTRIC RATING:	1250VAC for 1 second between pins 1-4. 1250VAC for 1 second between pins 1-8.
INDUCTANCE:	550 µH ±5%, 10kHz, 100mVAC, 0mADC, 1-3, Ls.
SATURATION CURRENT:	1.45A saturating current that causes 20% rolloff from initial inductance.
LEAKAGE INDUCTANCE:	10µH typ, 15µH max., 100kHz, 100mVAC, 1-3(tie 2+4), Ls. 24µH typ, 35µH max., 100kHz, 100mVAC, 1-3(tie 7+8), Ls.
TURNS RATIO:	(1-3);(2-4), (1);(1.00), ±1%. (1-3);(7-8), (4);(1.00), ±1%.

Designed for functional insulation

OPERATING TEMPERATURE RANGE: -40°C to 125°C including temp. rise.

Wire insulation & RoHS status not affected by wire color. Wire insulation color may vary depending on availability.

Würth Electronics Midcom Inc. Watertown, SD USA Toll Free: 800-643-2661 Fax: 605-886-4486	Unless otherwise specified, tolerances are as follows: Angles: ±1° Fractions: ±1/64 Decimals: ±.005(.127mm) Footprint: ±.001(.03mm)	more than you expect	
	Drawing Title <h2 style="margin: 0;">Transformer</h2>	Drawing Number <h2 style="margin: 0;">750314910</h2>	Rev. <h2 style="margin: 0;">00</h2>
This drawing is dual dimensioned. Dimensions in brackets are in millimeters	Revisions: See Sheet 1	Scale ----	Spec Sheet 1 of 1
Engineer: LJG		07/02/2014	

TEST PROCEDURE

Equipment Needed

- AC Source – 90 to 305 V ac 50/60 Hz Minimum 500 W Capability.
- AC Wattmeter – 300 W Minimum, True RMS Input Voltage, Current, Power Factor, and THD 0.2% Accuracy or Better.
- DC Voltmeter – 300 V dc minimum 0.1% Accuracy or Better.
- DC Ammeter – 1 A dc Minimum 0.1% Accuracy or Better.
- LED Load – 75 V @ 0.1 A. A Constant Voltage Electronic Load is an Acceptable Substitute for the LEDs as long as it is Stable.

Test Connections

1. Connect the LED Load to the red(+) and black(-) leads through the ammeter shown in Figure 11. **Caution: Observe the correct polarity or the load may be damaged.**
2. Connect the AC power to the input of the AC wattmeter shown in Figure 11. Connect the white leads to the output of the AC wattmeter
3. Connect the DC voltmeter as shown in Figure 11.

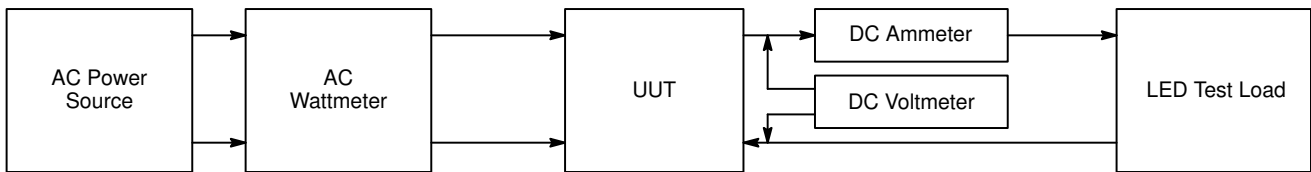

NOTE: Unless otherwise specified, all voltage measurements are taken at the terminals of the UUT.

Figure 11. Test Set Up

Functional Test Procedure

1. Set the LED Load for 75 V Output.
 2. Set the Input Power to 120 V 60 Hz.
- Caution: Do not touch the ECA once it is energized because there are hazardous voltages present.**

EVBUM2293/D

Line and Load Regulation

Table 1. 120 V/MAX LOAD

LED Output	Output Current 100 mA ± 3 mA	Output Power	Power Factor	
75 V				3.3 V Load = 0
75 V				3.3 V Load = 20 mA

Aux Voltage	Output Voltage			
	Min	Measured	Max	
3.3 V	3.0 V		3.6 V	LED Current = Max
3.3 V	3.0 V		3.6 V	LED Current = 0 (Dim = 0 V)
3.3 V	3.0 V		3.6 V	On/Off = Off

Table 2. 230 V/MAX LOAD

LED Output	Output Current 100 mA ± 3 mA	Output Power	Power Factor	
75 V				3.3 V Load = 0
75 V				3.3 V Load = 20 mA

Aux Voltage	Output Voltage			
	Min	Measured	Max	
3.3 V	3.0 V		3.6 V	LED Current = Max
3.3 V	3.0 V		3.6 V	LED Current = 0 (Dim = 0 V)
3.3 V	3.0 V		3.6 V	On/Off = Off

$$\text{Efficiency} = \frac{V_{\text{OUT}} \cdot I_{\text{OUT}}}{P_{\text{IN}}} \cdot 100\%$$

EVBUM2293/D

TEST DATA

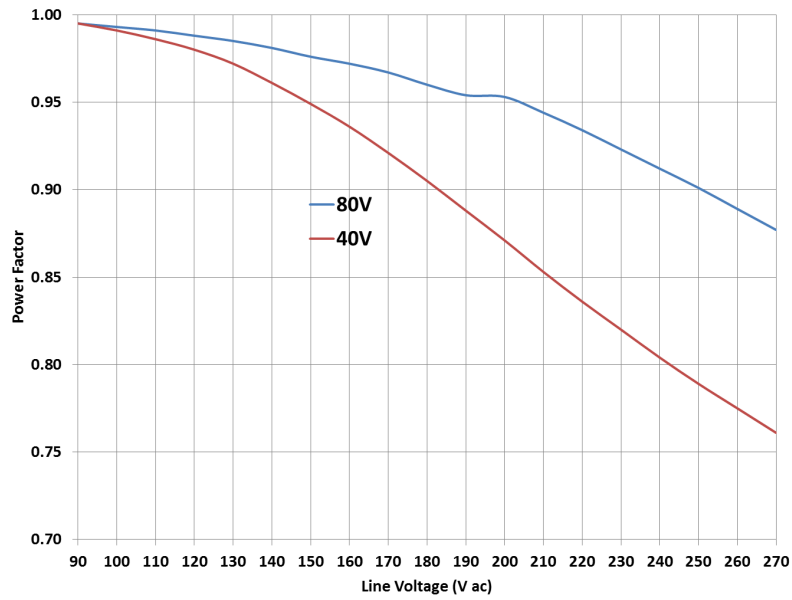

Figure 12. Power Factor over Line and Load

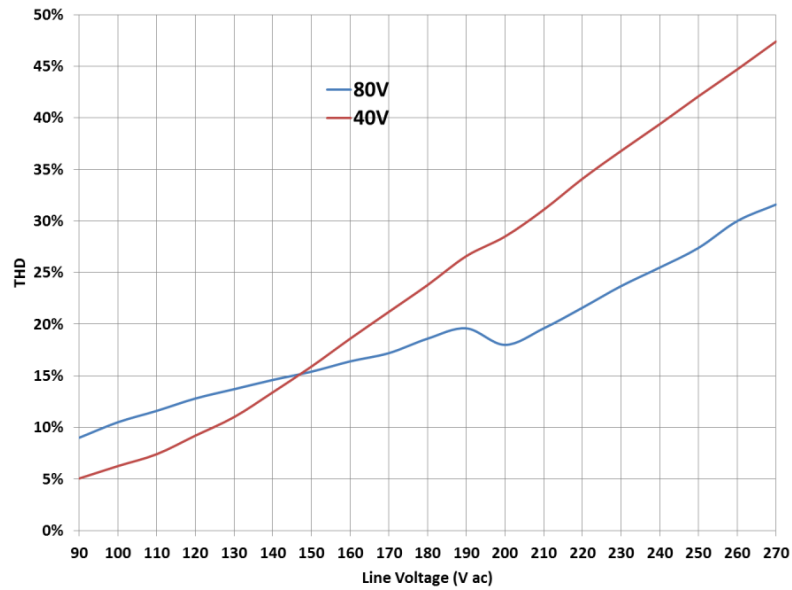

Figure 13. THD over Line and Load

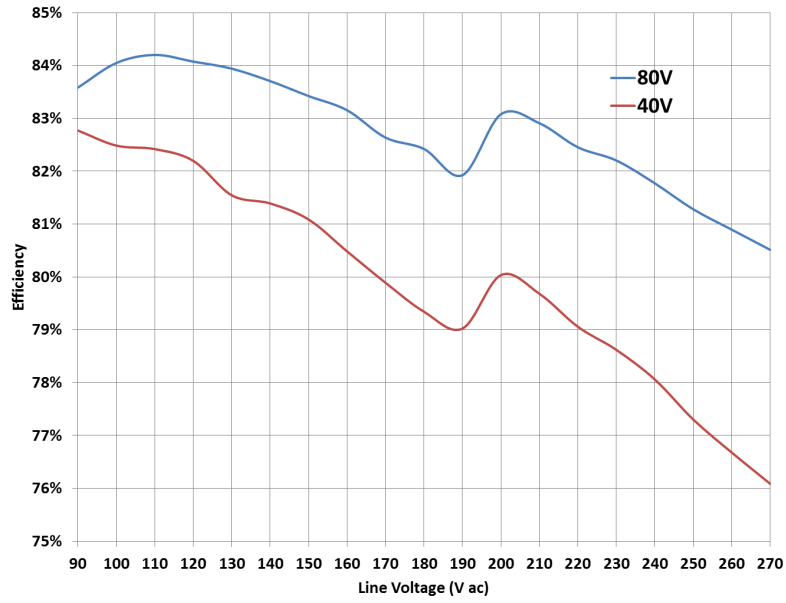

Figure 14. Efficiency over Line and Load

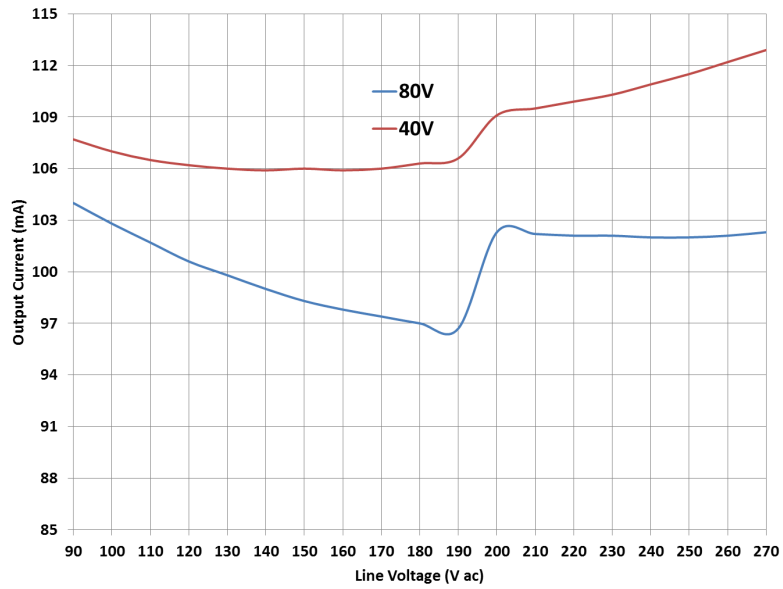

Figure 15. Regulation over Line

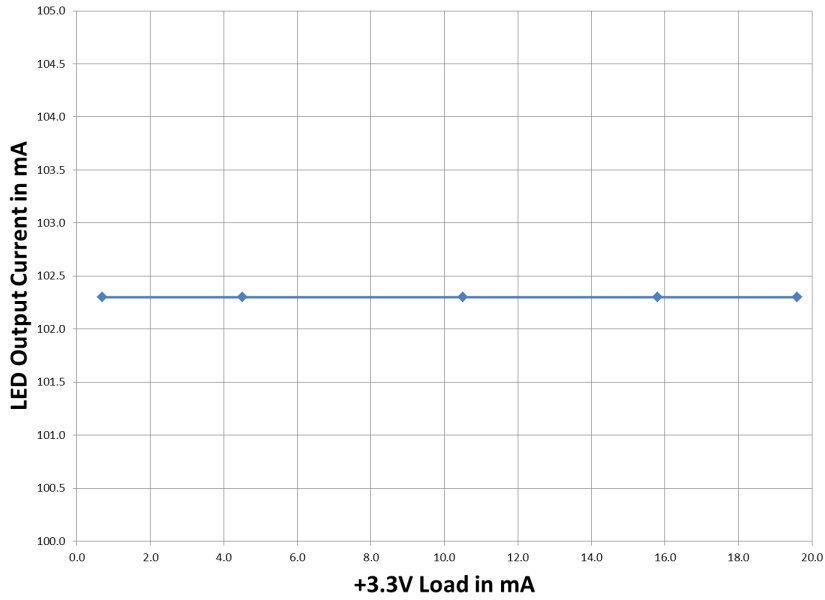

Figure 16. Cross Regulation Effect of +3.3 V Load on Output Current

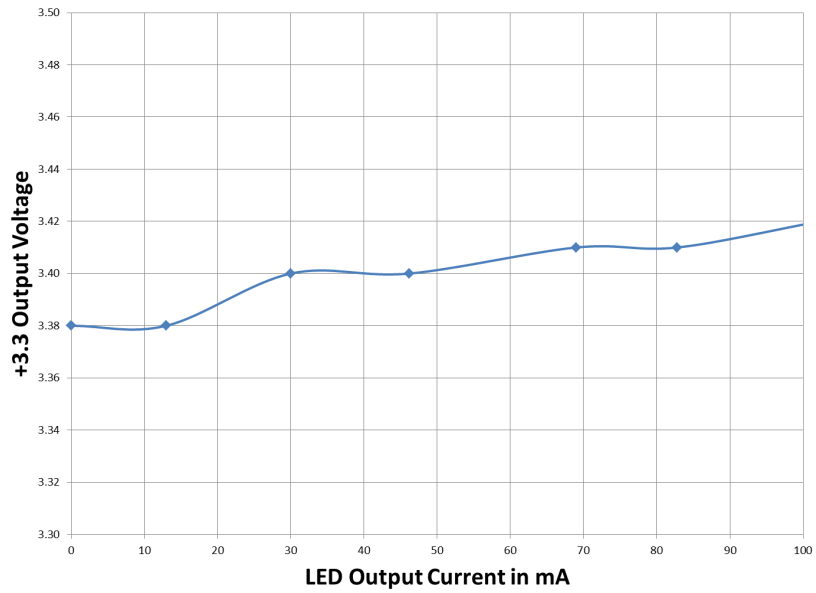

Figure 17. Cross Regulation Effect of Output Current on +3.3 V Output

EVBUM2293/D

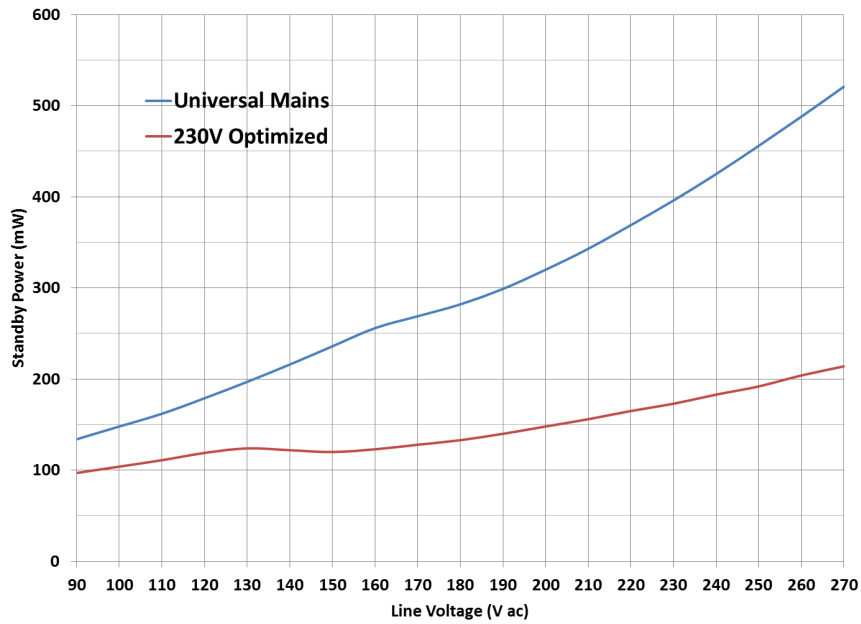

Figure 18. Standby Power Consumption over Line

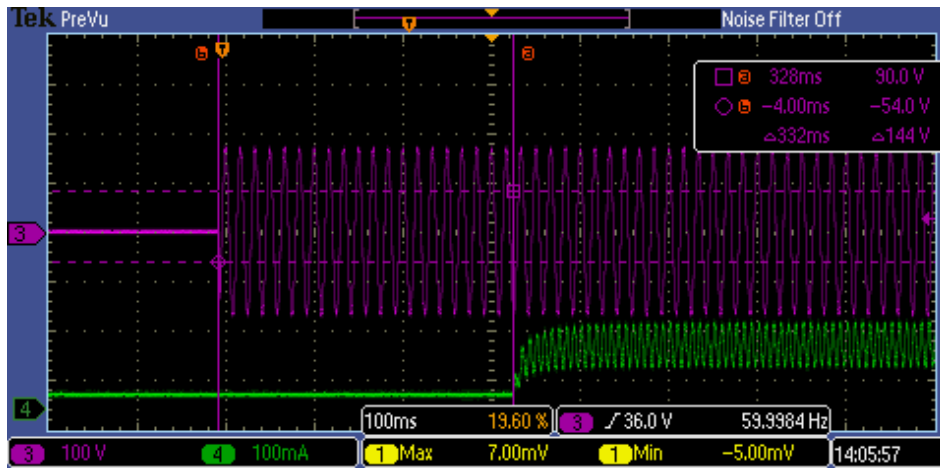

Figure 19. Start Up with AC Applied 120 V Maximum Load

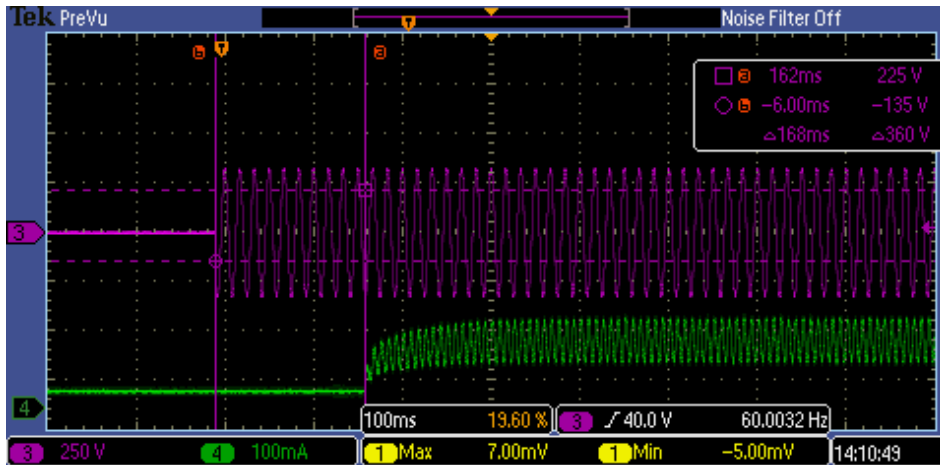

Figure 20. Start Up with AC Applied 230 V Maximum Load

EVBUM2293/D

IEC61000-3-2 TEST RESULTS

Product: NCL30086_Smart		Serial No.: N/A		27-Oct-2014 2:50:50PM	
Description: This is a test of the NCL30086 for Class C				Page: 1 of 1	
Voltech Pre-Compliance IEC61000-3-2 Windows Software			Test Date: 27th Oct 2014 14:46:46 PM		
Type of Test: IEC61000-3-2:2005 with Interharmonics to EN61000-4-7:2002				- Worst Case Table	
Power Analyzer: Voltech,PM1000+,100008202290,Ver.4.25			AC Source: Mains / AC Source		
Notes:		Overall Result PASS		Class: Class C, <=25W	
				Class Multiplier: 1	
Equipment rated <75W and Not class C.					
<L1 : Reading is below limit 1. <L2 : Reading is below limit 2. *x: Where Class D test has failed mA/W. <L2 (A) Reading is below 200% Class A Only. N/A : Harmonic current below 0.6% of rated current or 5mA, whichever is greater Or where the test is not applicable.					

Harm	Limit1	Limit2	Avg Rdg	<L1	<L2	Max Rdg	<L2(A)	PassFail
2	N/A	N/A	N/A	N/A	N/A	N/A	N/A	N/A
3	32.172mA	48.258mA	7.8119mA	√	√	7.8384mA	N/A	Pass
4	N/A	N/A	N/A	N/A	N/A	N/A	N/A	N/A
5	17.978mA	26.968mA	5.1631mA	√	√	5.1912mA	N/A	Pass
6	N/A	N/A	N/A	N/A	N/A	N/A	N/A	N/A
7	9.4625mA	14.193mA	2.0181mA	N/A	N/A	2.0335mA	N/A	Pass
8	N/A	N/A	N/A	N/A	N/A	N/A	N/A	N/A
9	4.7312mA	7.0968mA	671.74uA	N/A	N/A	691.38uA	N/A	Pass
10	N/A	N/A	N/A	N/A	N/A	N/A	N/A	N/A
11	3.3118mA	4.9678mA	1.8833mA	N/A	N/A	1.9493mA	N/A	Pass
12	N/A	N/A	N/A	N/A	N/A	N/A	N/A	N/A
13	2.8009mA	4.2013mA	1.7378mA	N/A	N/A	1.7618mA	N/A	Pass
14	N/A	N/A	N/A	N/A	N/A	N/A	N/A	N/A
15	2.4224mA	3.6336mA	1.0112mA	N/A	N/A	1.0305mA	N/A	Pass
16	N/A	N/A	N/A	N/A	N/A	N/A	N/A	N/A
17	2.1385mA	3.2077mA	1.1958mA	N/A	N/A	1.2188mA	N/A	Pass
18	N/A	N/A	N/A	N/A	N/A	N/A	N/A	N/A
19	1.9114mA	2.8671mA	1.1528mA	N/A	N/A	1.1788mA	N/A	Pass
20	N/A	N/A	N/A	N/A	N/A	N/A	N/A	N/A
21	1.7316mA	2.5974mA	883.20uA	N/A	N/A	904.48uA	N/A	Pass
22	N/A	N/A	N/A	N/A	N/A	N/A	N/A	N/A
23	1.5802mA	2.3703mA	1.0104mA	N/A	N/A	1.0805mA	N/A	Pass
24	N/A	N/A	N/A	N/A	N/A	N/A	N/A	N/A
25	1.4572mA	2.1858mA	878.98uA	N/A	N/A	899.97uA	N/A	Pass
26	N/A	N/A	N/A	N/A	N/A	N/A	N/A	N/A
27	1.3436mA	2.0155mA	821.84uA	N/A	N/A	839.62uA	N/A	Pass
28	N/A	N/A	N/A	N/A	N/A	N/A	N/A	N/A
29	1.2490mA	1.8735mA	677.77uA	N/A	N/A	698.32uA	N/A	Pass
30	N/A	N/A	N/A	N/A	N/A	N/A	N/A	N/A
31	1.1733mA	1.7600mA	711.21uA	N/A	N/A	732.77uA	N/A	Pass
32	N/A	N/A	N/A	N/A	N/A	N/A	N/A	N/A
33	1.0976mA	1.6464mA	679.00uA	N/A	N/A	702.14uA	N/A	Pass
34	N/A	N/A	N/A	N/A	N/A	N/A	N/A	N/A
35	1.0408mA	1.5613mA	581.55uA	N/A	N/A	601.48uA	N/A	Pass
36	N/A	N/A	N/A	N/A	N/A	N/A	N/A	N/A
37	0.9841mA	1.4761mA	679.90uA	N/A	N/A	696.94uA	N/A	Pass
38	N/A	N/A	N/A	N/A	N/A	N/A	N/A	N/A
39	0.9273mA	1.3909mA	675.06uA	N/A	N/A	691.11uA	N/A	Pass
40	N/A	N/A	N/A	N/A	N/A	N/A	N/A	N/A

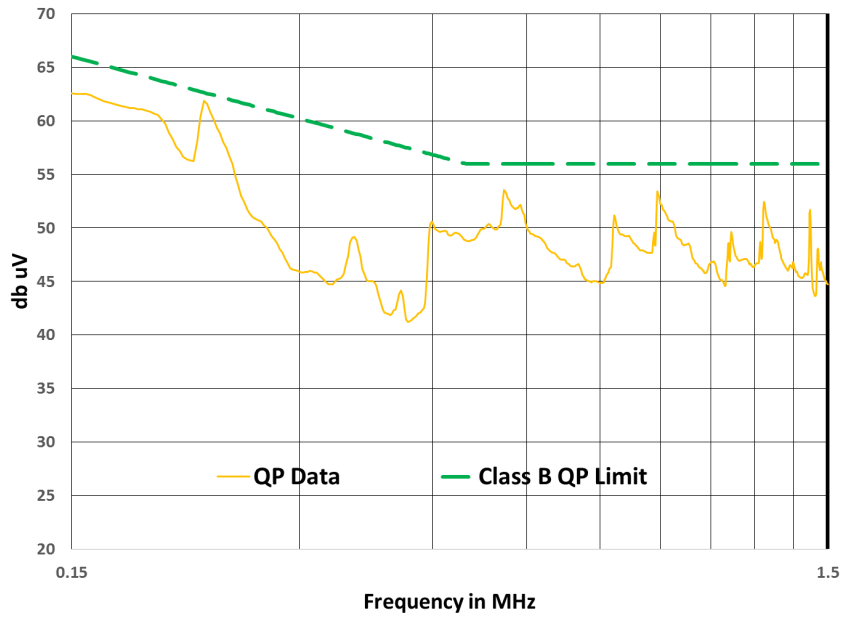

Figure 21. Pre-compliance Conducted EMI 150 kHz – 1.5 MHz

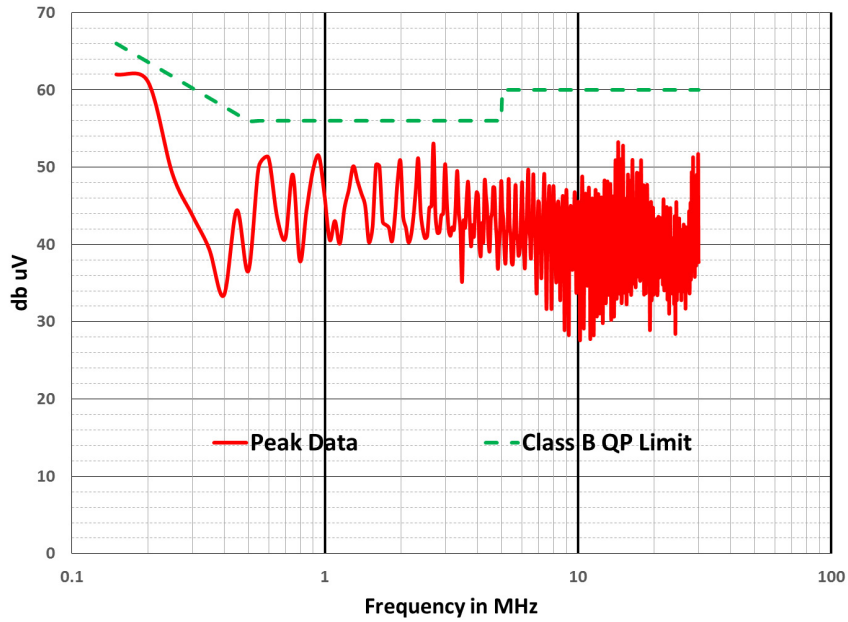

Figure 22. Pre-compliance Conducted EMI 150 kHz – 30 MHz

EVBUM2293/D

BILL OF MATERIALS

Table 3. BILL OF MATERIALS

Quantity	Reference	Part	Manufacturer	Manufacturer Part Number	PCB Footprint	Substitution Allowed
1	CV _{CC1}	4.7 μ F	AVX	TAJB475M035RNJ	1210	Yes
1	C _{OUT}	33 μ F, 100 V	Rubycon	100ZLJ33M8X11.5	CAP_AL_8X11	Yes
3	C13, C15, C _{ZIG}	4.7 μ F	Taiyo Yuden	EMK107ABJ475KA-T	603	Yes
2	C3, C4	100 nF, 400 V	Epcos	B32559C6104+***	CAP-BOX-LS5-5M0X7M2	Yes
1	C5	120 nF, 400 V	Epcos	B32559C6124+***	CAP-BOX-LS5-5M0X7M2	Yes
2	C10, C14	1 nF	Kemet	C0402C102K3GACTU	402	Yes
1	C12	1.0 μ F	Taiyo Yuden	GMK107AB7105KAHT	603	Yes
1	D _{OUT}	UFM15PL	MCC	UFM15PL	SOD123FL	Yes
1	D4	ABS10	Comchip	ABS10	ABS10	Yes
2	D9, D13	BAS21DW5T1G	ON Semiconductor	BAS21DW5T1G	SC-88A	No
3	D10, D12, D15	MM5Z15VT1G	ON Semiconductor	MM5Z15VT1G	SOD523	No
1	D11	BAS116LT1G	ON Semiconductor	BAS116LT1G	SOT23	No
1	D14	BAS16XV2T1G	ON Semiconductor	BAS16XV2T1G	SOD523	No
1	F1	FUSE	Littelfuse	0263.500WRT1L	FUSE-HAIRPIN-LS25	Yes
1	J1	CON3	Wurth	6.91102E+11	CONN_3P_SCRMNT	Yes
1	J6	CON7	On Shore	OSTTA074163	CONN_7P_SCRMNT	Yes
2	L1, L2	1.5 mH	Wurth	7447462152	IND-UPRIGHT-LS25	Yes
1	Q _{FET}	NDD02N60Z	ON Semiconductor	NDD02N60Z	IPAK	No
2	Q1, Q2	MMBT3904WT1G	ON Semiconductor	MMBT3904WT1G	SOT323	No
1	Q3	MMBT5551LT1G	ON Semiconductor	MMBT5551LT1G	SOT23	No
1	Q4	BSS138	ON Semiconductor	BSS138	SOT23	No
1	R _{DAMP}	180 Ω	Yaego	RC0805JR-07180RL	805	Yes
1	R _{SENS}	1 Ω	Yaego	RC1206FR-071RL	1206	Yes
1	R _{TCO}	100 k Ω NTC	Epcos	B57331V2104J60	603	Yes
2	R5, R _{ZCD}	56 k Ω	Yaego	RC0805FR-0756KL	805	Yes
2	R3, R11	12 k Ω	Yaego	RC0402FR-0712KL	402	Yes
2	R4, R13	200 k Ω	Yaego	RV1206FR-07200KL	1206	Yes
2	R6, R10	10 k Ω	Yaego	RC0402FR-0710KL	402	Yes
1	R7	470 Ω	Yaego	RC0402FR-07470RL	402	Yes
4	R8, R9, R15, R19	100 k Ω	Yaego	RC0402FR-07100KL	402	Yes
1	R12	620 k Ω	Yaego	RC1206FR-07620KL	1206	Yes
1	R14	330 Ω	Yaego	RC0402FR-07330RL	402	Yes
1	R16	40.2 k Ω	Yaego	RC0402FR-0740k2L	402	Yes
1	R18	62 Ω	Yaego	RC0402FR-0762RL	402	Yes
1	R21	3.32 k Ω	Yaego	RC0402FR-073K32L	402	Yes
1	T1	XFRM_LINEAR	Wurth	750314910	RM6-8P-TH	Yes
1	U2	LP2951ACDM-3.3	ON Semiconductor	LP2951ACDM-3.3	MICRO8	No
1	U3	NCL30086B	ON Semiconductor	NCL30086	SO10	No
1	U4	NCP431A	ON Semiconductor	NCP431A	SOT23	No
1	U5	LM317	ON Semiconductor	LM317LBD2G	TO-92	No

NOTE: All Components to comply with RoHS 2002/95/EC.

Microsoft Excel is a registered trademark of Microsoft Corporation.

ON Semiconductor and the  are registered trademarks of Semiconductor Components Industries, LLC (SCILLC) or its subsidiaries in the United States and/or other countries. SCILLC owns the rights to a number of patents, trademarks, copyrights, trade secrets, and other intellectual property. A listing of SCILLC's product/patent coverage may be accessed at www.onsemi.com/site/pdf/Patent-Marking.pdf. SCILLC reserves the right to make changes without further notice to any products herein. SCILLC makes no warranty, representation or guarantee regarding the suitability of its products for any particular purpose, nor does SCILLC assume any liability arising out of the application or use of any product or circuit, and specifically disclaims any and all liability, including without limitation special, consequential or incidental damages. "Typical" parameters which may be provided in SCILLC data sheets and/or specifications can and do vary in different applications and actual performance may vary over time. All operating parameters, including "Typicals" must be validated for each customer application by customer's technical experts. SCILLC does not convey any license under its patent rights nor the rights of others. SCILLC products are not designed, intended, or authorized for use as components in systems intended for surgical implant into the body, or other applications intended to support or sustain life, or for any other application in which the failure of the SCILLC product could create a situation where personal injury or death may occur. Should Buyer purchase or use SCILLC products for any such unintended or unauthorized application, Buyer shall indemnify and hold SCILLC and its officers, employees, subsidiaries, affiliates, and distributors harmless against all claims, costs, damages, and expenses, and reasonable attorney fees arising out of, directly or indirectly, any claim of personal injury or death associated with such unintended or unauthorized use, even if such claim alleges that SCILLC was negligent regarding the design or manufacture of the part. SCILLC is an Equal Opportunity/Affirmative Action Employer. This literature is subject to all applicable copyright laws and is not for resale in any manner.

PUBLICATION ORDERING INFORMATION

LITERATURE FULFILLMENT:

Literature Distribution Center for ON Semiconductor
P.O. Box 5163, Denver, Colorado 80217 USA
Phone: 303-675-2175 or 800-344-3860 Toll Free USA/Canada
Fax: 303-675-2176 or 800-344-3867 Toll Free USA/Canada
Email: orderlit@onsemi.com

N. American Technical Support: 800-282-9855 Toll Free
USA/Canada
Europe, Middle East and Africa Technical Support:
Phone: 421 33 790 2910
Japan Customer Focus Center
Phone: 81-3-5817-1050

ON Semiconductor Website: www.onsemi.com
Order Literature: <http://www.onsemi.com/orderlit>
For additional information, please contact your local
Sales Representative