



Chipsmall Limited consists of a professional team with an average of over 10 year of expertise in the distribution of electronic components. Based in Hongkong, we have already established firm and mutual-benefit business relationships with customers from,Europe,America and south Asia,supplying obsolete and hard-to-find components to meet their specific needs.

With the principle of “Quality Parts,Customers Priority,Honest Operation,and Considerate Service”,our business mainly focus on the distribution of electronic components. Line cards we deal with include Microchip,ALPS,ROHM,Xilinx,Pulse,ON,Everlight and Freescale. Main products comprise IC,Modules,Potentiometer,IC Socket,Relay,Connector.Our parts cover such applications as commercial,industrial, and automotives areas.

We are looking forward to setting up business relationship with you and hope to provide you with the best service and solution. Let us make a better world for our industry!



## Contact us

Tel: +86-755-8981 8866 Fax: +86-755-8427 6832

Email & Skype: info@chipsmall.com Web: www.chipsmall.com

Address: A1208, Overseas Decoration Building, #122 Zhenhua RD., Futian, Shenzhen, China



# NCL30288

## Product Preview

# Power Factor Corrected Quasi-Resonant Primary Side Current-Mode Controller for LED Lighting

The NCL30288 is a compact driver for power-factor corrected flyback and non-isolated buck-boost and SEPIC converters. The controller operates in a quasi-resonant mode to provide optimal efficiency, and embeds a proprietary control method which allows the LED current to be tightly regulated from the primary side, thus eliminating the need for a secondary-side feedback circuitry and for an optocoupler.

Housed in a TSOP-6 package, the device is highly integrated with a minimum number of external components. A robust suite of safety protection is built in to simplify the design. This device is specifically intended for very compact space efficient designs.

### Features

- Quasi-resonant Peak Current-mode Control Operation
- Constant Current Control with Primary Side Feedback
- Tight LED Constant Current Regulation of  $\pm 2\%$  typical
- Near-Unity Power Factor ( $>0.95$  typically)
- Optimized for Line Wide-range Applications
- Line Feedforward for Enhanced Regulation Accuracy
- Low Start-up Current (10  $\mu\text{A}$  typ.)
- Wide  $V_{CC}$  Range
- 300 mA / 500 mA Totem Pole Driver with 12 V Gate Clamp
- Robust Protection Features
  - ◆ OVP on  $V_{CC}$
  - ◆ Programmable Over Voltage / LED Open Circuit Protection
  - ◆ Cycle by cycle peak current limit
  - ◆ Winding Short Circuit Protection
  - ◆ Secondary Diode Short Protection
  - ◆ Output Short Circuit Protection
  - ◆ Thermal Shutdown
  - ◆  $V_{CC}$  Undervoltage Lockout
  - ◆ Brown-Out Detection
- Pb-Free, Halide-Free MSL1 Product

### Typical Application

- Integral LED Bulbs and Tubes
- LED Light Engines
- LED Drivers / Power Supplies

This document contains information on a product under development. ON Semiconductor reserves the right to change or discontinue this product without notice.



ON Semiconductor®

[www.onsemi.com](http://www.onsemi.com)



1

TSOP-6  
CASE 318G-02

### MARKING DIAGRAM

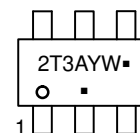

2T3 = Specific Device Code

A = Assembly Location

Y = Year

W = Work Week

■ = Pb-Free Package

(Note: Microdot may be in either location)

### PIN CONNECTIONS

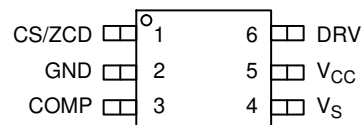

### ORDERING INFORMATION

Device	Package	Shipping†
NCL30288BSNT1G	TSOP-6 (Pb-Free/ Halide Free)	3000 / Reel

†For information on tape and reel specifications, including part orientation and tape sizes, please refer to our Tape and Reel Packaging Specification Brochure, BRD8011/D.

TYPICAL APPLICATION SCHEMATIC

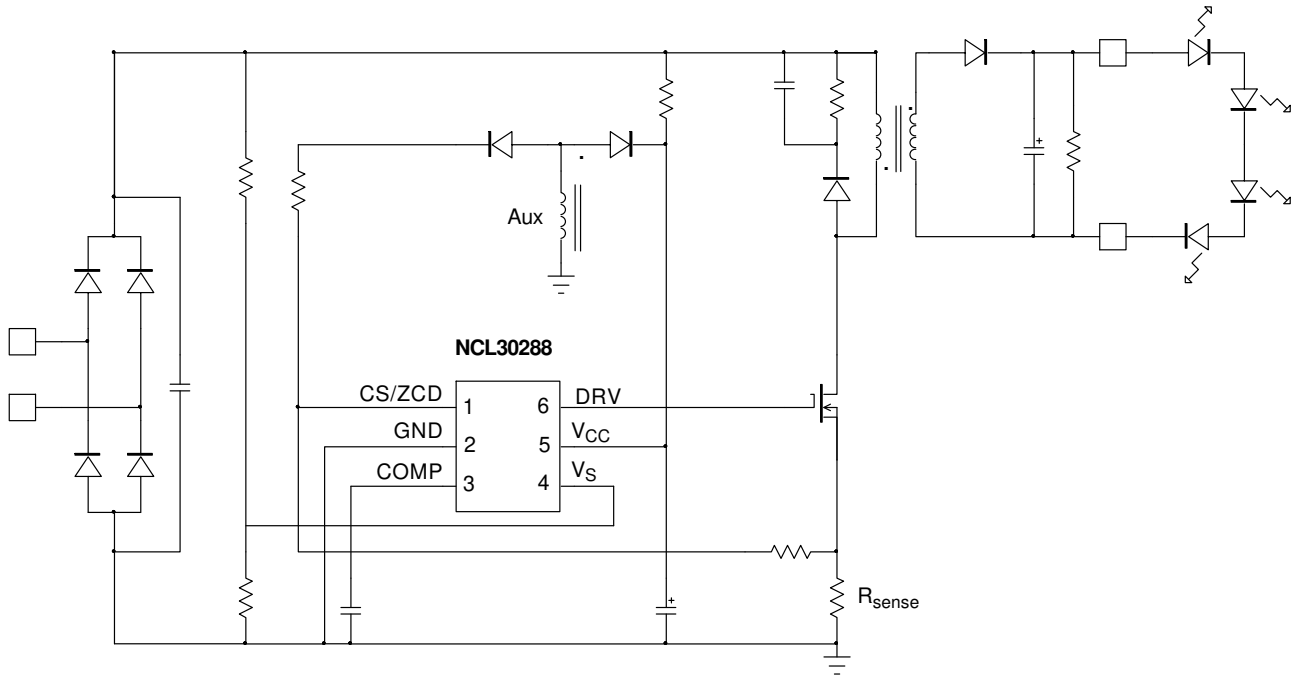

Figure 1. Typical Application Schematic in a Flyback Converter

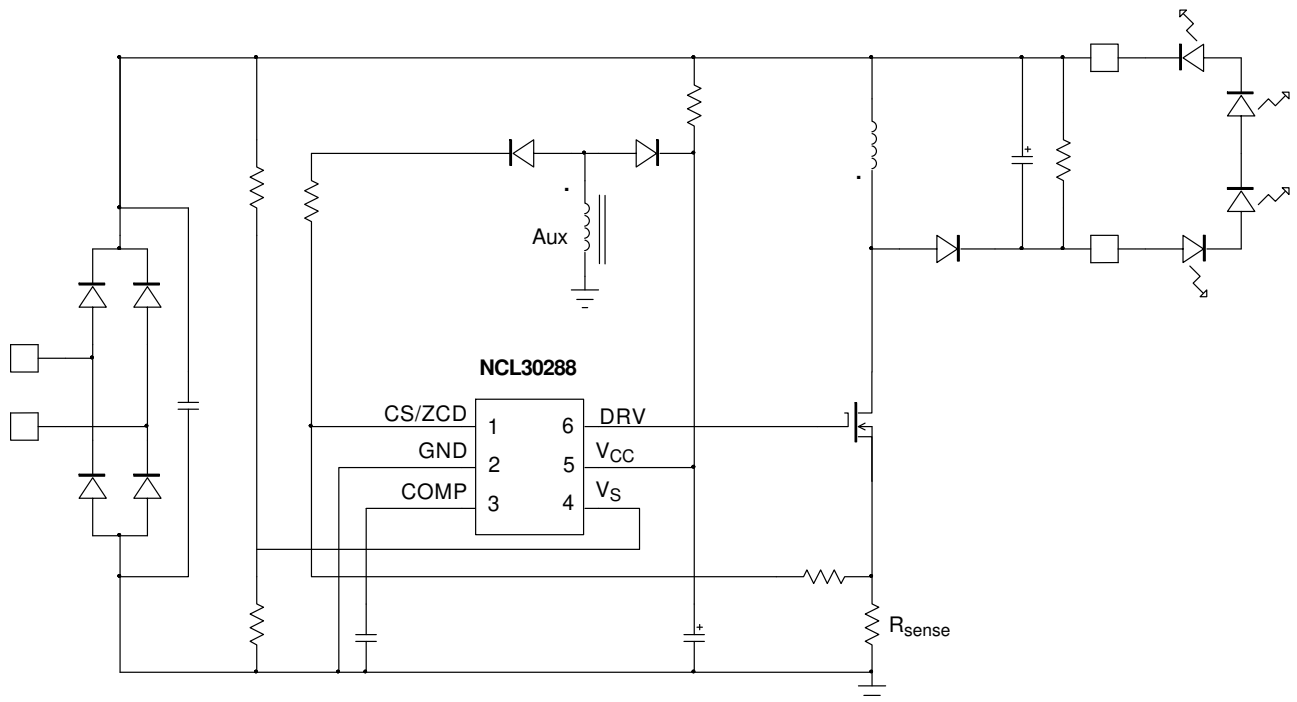

Figure 2. Typical Application Schematic in a Buck-Boost Converter

# NCL30288

**Table 1. PIN FUNCTION DESCRIPTION**

Pin #	Pin Name	Function	Pin Description
1	CS/ZCD	Current Sense and Zero Current Detection	This multi-function pin is designed to monitor the primary peak current for protection and output current control and the auxiliary winding voltage for zero current detection
2	GND		Controller ground pin
3	COMP	Filtering Capacitor	This pin receives a filtering capacitor for power factor correction. Typical values ranges from 0.47 – 4.70 $\mu$ F
4	V <sub>S</sub>	Input Voltage Sensing	This pin observes the input voltage rail and protects the LED driver in case of too low mains conditions (brown-out). This pin also observes the input voltage rail for: <ul style="list-style-type: none"><li>– Power Factor Correction</li><li>– Line Range Detection</li></ul>
5	V <sub>CC</sub>	IC Supply Pin	This pin is the positive supply of the IC. The circuit starts to operate when V <sub>CC</sub> exceeds 18 V and turns off when V <sub>CC</sub> goes below 8.8 V (typical values). After start-up, the operating range is 9.4 V up to 25.5 V (V <sub>CC(OVP)</sub> minimum level).
6	DRV	Driver Output	The driver's output to an external MOSFET

INTERNAL CIRCUIT ARCHITECTURE

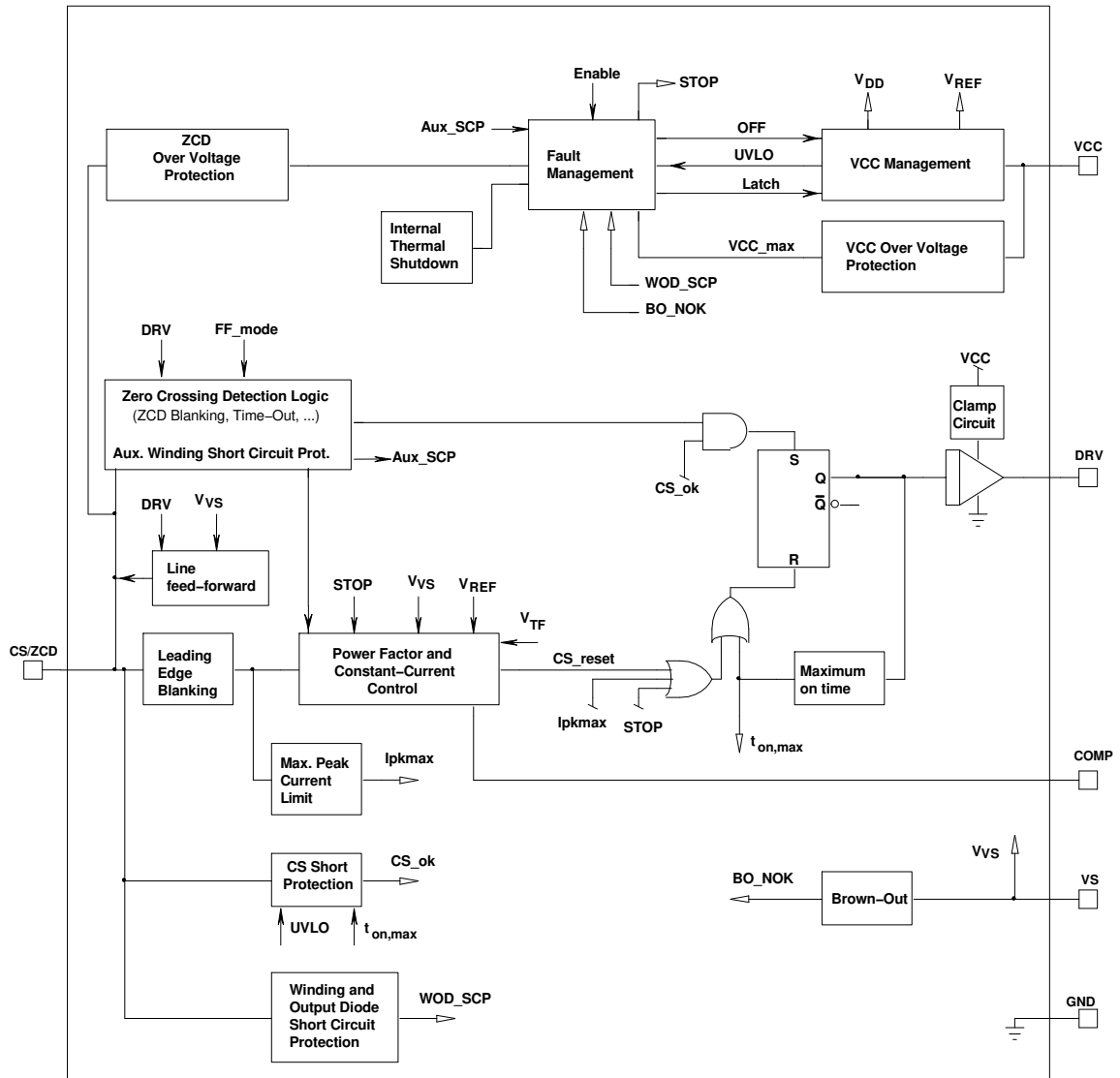

Figure 3. Internal Circuit Architecture

Table 2. MAXIMUM RATINGS TABLE

Symbol	Rating	Value	Units
$V_{CC(MAX)}$ $I_{CC(MAX)}$	Maximum Power Supply voltage, $V_{CC}$ pin, continuous voltage Maximum current for $V_{CC}$ pin	-0.3 to 30 Internally limited	V mA
$V_{DRV(MAX)}$ $I_{DRV(MAX)}$	Maximum driver pin voltage, DRV pin, continuous voltage Maximum current for DRV pin	-0.3, $V_{DRV}$ (Note 1) -300, +500	V mA
$V_{MAX}$ $I_{MAX}$	Maximum voltage on low power pins (except DRV and $V_{CC}$ pins) Current range for low power pins (except DRV and $V_{CC}$ pins)	-0.3, 5.5 (Notes 2 and 5) -2, +5	V mA
$R_{\theta J-A}$	Thermal Resistance Junction-to-Air	360	°C/W
$T_{J(MAX)}$	Maximum Junction Temperature	150	°C
	Operating Temperature Range	-40 to +125	°C
	Storage Temperature Range	-60 to +150	°C
	ESD Capability, Human Body Model (HBM) (Note 3)	3.5	kV
	ESD Capability, Machine Model (MM) (Note 3)	250	V

Stresses exceeding those listed in the Maximum Ratings table may damage the device. If any of these limits are exceeded, device functionality should not be assumed, damage may occur and reliability may be affected.

- $V_{DRV}$  is the DRV clamp voltage  $V_{DRV(high)}$  when  $V_{CC}$  is higher than  $V_{DRV(high)}$ .  $V_{DRV}$  is  $V_{CC}$  otherwise.
- This level is low enough to guarantee not to exceed the internal ESD diode and 5.5 V ZENER diode. More positive and negative voltages can be applied if the pin current stays within the -2 mA / 5 mA range.
- This device contains ESD protection and exceeds the following tests: Human Body Model 3500 V per JEDEC Standard JESD22-A114E, Machine Model Method 250 V per JEDEC Standard JESD22-A115B.
- This device contains latch-up protection and exceeds 100 mA per JEDEC Standard JESD78.
- Recommended maximum  $V_S$  voltage for optimal operation is 4 V.

# NCL30288

**Table 3. ELECTRICAL CHARACTERISTICS**

(Unless otherwise noted: For typical values  $T_J = 25^\circ\text{C}$ ,  $V_{CC} = 12\text{ V}$ ,  $V_{CS/ZCD} = 0\text{ V}$   
For min/max values  $T_J = -40^\circ\text{C}$  to  $+125^\circ\text{C}$ , Max  $T_J = 150^\circ\text{C}$ ,  $V_{CC} = 12\text{ V}$ )

Description	Test Condition	Symbol	Min	Typ	Max	Unit
<b>Startup and Supply Circuits</b>						
Supply Voltage						V
Startup Threshold	$V_{CC}$ increasing	$V_{CC(on)}$	16.0	18.0	20.0	
Minimum Operating Voltage	$V_{CC}$ decreasing	$V_{CC(off)}$	8.2	8.8	9.4	
Hysteresis $V_{CC(on)} - V_{CC(off)}$	$V_{CC}$ decreasing	$V_{CC(HYS)}$	8.0	–	–	
Internal logic reset	$V_{CC}$ decreasing	$V_{CC(reset)}$	4.0	4.8	6.0	
Threshold for $V_{CC}$ Over Voltage Protection		$V_{CC(OVP)}$	25.5	26.8	28.5	V
$V_{CC(off)}$ noise filter		$t_{VCC(off)}$	–	5	–	$\mu\text{s}$
$V_{CC(reset)}$ noise filter		$t_{VCC(reset)}$	–	20	–	
Startup current	$V_{CC}=15.9\text{ V}$	$I_{CC(start)}$	–	13	30	$\mu\text{A}$
Startup current in fault mode		$I_{CC(sFault)}$	–	58	75	$\mu\text{A}$
Supply Current						mA
Device Disabled / Fault	$V_{CC} > V_{CC(off)}$	$I_{CC1}$	1.15	1.34	1.55	
Device Enabled / No output load on pin 5	$F_{sw} = 65\text{ kHz}$	$I_{CC2}$	–	2.0	3.5	
Device Switching	$C_{DRV} = 470\text{ pF}$ , $F_{sw} = 65\text{ kHz}$	$I_{CC3}$	–	2.5	4.0	
<b>Current Sense</b>						
Maximum Internal current limit		$V_{ILIM}$	0.94	0.99	1.04	V
Leading Edge Blanking Duration for Current Sensing		$t_{LEB}$	220	275	340	ns
Propagation delay from current detection to gate off-state		$t_{ILIM}$	–	100	150	ns
Maximum on-time		$t_{on(MAX)}$	26	36	46	$\mu\text{s}$
Threshold for immediate fault protection activation		$V_{CS(stop)}$	1.35	1.50	1.65	V
Leading Edge Blanking Duration for $V_{CS(stop)}$ (Note 1)		$t_{BCS}$	–	175	–	ns
Current source for CS to GND short detection		$I_{CS(short)}$	420	520	620	$\mu\text{A}$
Current sense threshold for CS to GND short detection	$V_{CS}$ rising	$V_{CS(low)}$	30	90	150	mV
<b>Gate Drive</b>						
Drive Resistance						$\Omega$
DRV Sink		$R_{SNK}$	–	13	–	
DRV Source		$R_{SRC}$	–	30	–	
Drive current capability						mA
DRV Sink (Note GBD)		$I_{SNK}$	–	500	–	
DRV Source (Note GBD)		$I_{SRC}$	–	300	–	
Rise Time (10 % to 90 %)	$C_{DRV} = 470\text{ pF}$	$t_r$	–	40	–	ns
Fall Time (90 % to 10 %)	$C_{DRV} = 470\text{ pF}$	$t_f$	–	30	–	ns
DRV Low Voltage	$V_{CC} = V_{CC(off)} + 0.2\text{ V}$ $C_{DRV} = 470\text{ pF}$ , $R_{DRV} = 33\text{ k}\Omega$	$V_{DRV(low)}$	8	–	–	V
DRV High Voltage	$V_{CC} = V_{CC(MAX)}$ $C_{DRV} = 470\text{ pF}$ , $R_{DRV} = 33\text{ k}\Omega$	$V_{DRV(high)}$	10	12	14	V
<b>Zero Voltage Detection Circuit</b>						
Upper ZCD threshold voltage	$V_{ZCD}$ rising	$V_{ZCD(rising)}$	–	90	150	mV
Lower ZCD threshold voltage	$V_{ZCD}$ falling	$V_{ZCD(falling)}$	35	55	–	mV
ZCD hysteresis		$V_{ZCD(HYS)}$	15	–	–	mV

**Table 3. ELECTRICAL CHARACTERISTICS**

(Unless otherwise noted: For typical values  $T_J = 25^\circ\text{C}$ ,  $V_{CC} = 12\text{ V}$ ,  $V_{CS/ZCD} = 0\text{ V}$   
For min/max values  $T_J = -40^\circ\text{C}$  to  $+125^\circ\text{C}$ , Max  $T_J = 150^\circ\text{C}$ ,  $V_{CC} = 12\text{ V}$ )

Description	Test Condition	Symbol	Min	Typ	Max	Unit
Propagation Delay from valley detection to DRV high	$V_{ZCD}$ decreasing	$t_{DEM}$	–	200	300	ns
Blanking delay after on–time (normal operation)		$t_{ZCD}(\text{blank}1)$	1.12	1.50	1.88	$\mu\text{s}$
Blanking delay after on–time (startup phase)		$t_{ZCD}(\text{blank}2)$	2.24	3.00	3.76	$\mu\text{s}$
Timeout after last DEMAG transition		$t_{TIMO}$	6.0	7.3	9.0	$\mu\text{s}$
Time for which the CS/ZCD pin is grounded when the DRV turns low	DRV falling	$T_1$	200	325	450	ns
Watch Dog Timer (restart timer in the absence of demagnetization signal like for instance in startup or short circuit conditions)		$t_{WDG}$	40	55	70	$\mu\text{s}$
Pulling–down resistor	$V_{ZCD} = V_{ZCD}(\text{falling})$	$R_{ZCD}(\text{pd})$		200		$\text{k}\Omega$

**Constant Current and Power Factor Control**

Reference Voltage at $T_J = 25^\circ\text{C}$		$V_{REF}$	195	200	205	mV
Reference Voltage at $T_J = 25^\circ\text{C}$ to $100^\circ\text{C}$		$V_{REF}$	192.5	200.0	207.5	mV
Reference Voltage at $T_J = -20^\circ\text{C}$ to $125^\circ\text{C}$		$V_{REF}$	190	200	210	mV
Reference Voltage $T_J = -40^\circ\text{C}$ to $125^\circ\text{C}$		$V_{REF}$	187.5	200.0	212.5	mV
$V_{control}$ to current setpoint division ratio		$V_{ratio}$	–	4	–	–
Error amplifier gain	$V_{REFX} = V_{REF}$	$G_{EA}$	44	54	64	$\mu\text{S}$
Error amplifier current capability	$V_{REFX} = V_{REF}$	$I_{EA}$		$\pm 60$		$\mu\text{A}$
COMP Pin Start–up Current Source	COMP pin grounded	$I_{EA\_STUP}$		125		$\mu\text{A}$

**Line Feed Forward**

$V_{VS}$ to $I_{CS}(\text{offset})$ conversion ratio		$K_{LFF}$	9.8	10.9	11.8	$\mu\text{S}$
Line feed–forward current on CS pin	DRV high, $V_{VS} = 2\text{ V}$	$I_{LFF}$	19.5	22.0	24.5	$\mu\text{A}$
Offset current maximum value	$V_{VS} > 5\text{ V}$	$I_{\text{offset}}(\text{MAX})$	44	53	64	$\mu\text{A}$

**Line Range Detection**

Threshold for high–line range (HL) detection	$V_{VS}$ rising	$V_{HL}$	1.9	2.0	2.1	V
Threshold for low–line range (LL) detection	$V_{VS}$ falling	$V_{LL}$	1.8	1.9	2.0	V
Blanking time for line range detection		$t_{HL}(\text{blank})$	15	25	35	ms

**Fault Protection**

Thermal Shutdown (Note 2)	$F_{SW} = 65\text{ kHz}$	$T_{SHDN}$	130	150	170	$^\circ\text{C}$
Thermal Shutdown Hysteresis		$T_{SHDN}(\text{HYS})$	–	50	–	$^\circ\text{C}$
Threshold voltage for output short circuit or aux. winding short circuit detection		$V_{ZCD}(\text{short})$	0.94	0.99	1.04	V
Short circuit detection Timer	$V_{ZCD} < V_{ZCD}(\text{short})$	$t_{OVL D}$	70	90	110	ms
Auto–recovery timer duration		$t_{recovery}$	3	4	5	s
CS/ZCD OVP Threshold		$V_{OVP2}$	4.32	4.50	4.68	V
Brown–Out ON level (IC start pulsing)	$V_S$ rising	$V_{BO}(\text{on})$	0.95	1.00	1.05	V
Brown–Out OFF level (IC shuts down)	$V_S$ falling	$V_{BO}(\text{off})$	0.85	0.90	0.95	V
BO comparators delay		$t_{BO}(\text{delay})$		30		$\mu\text{s}$
Brown–Out blanking time		$t_{BO}(\text{blank})$	15	25	35	ms
$V_S$ pin Pulling–down Current	$V_S = V_{BO}(\text{on})$	$I_{BO}(\text{bias})$	50	250	450	nA

1. The CS/ZCD pin is grounded for the  $t_{BCS}$  duration
2. Guaranteed by Design



## APPLICATION INFORMATION

The NCL30288 is designed to control flyback-, buck-boost- and SEPIC-based LED drivers. A proprietary circuitry ensures accurate primary-side regulation of the output current (without the need for a secondary-side feedback) and near-unity power factor correction. The circuit contains a suite of powerful protections to ensure a robust LED driver design without the need for extra components or overdesign.

- Quasi-Resonance Current-Mode Operation: implementing quasi-resonance operation in peak current-mode control, the NCL30288 optimizes the efficiency by switching in the valley of the MOSFET drain-source voltage in low-line conditions. When in high line, the circuit skips one valley to lower the switching frequency.
- Primary Side Constant Current Control with Power Factor Correction: proprietary circuitry allows the LED driver to achieve both near-unity power factor correction and accurate regulation of the output current without requiring any secondary-side feedback (no optocoupler needed). A power factor as high as 0.99 and an output current deviation below  $\pm 2\%$  are typically obtained.
- Main protection features:
  - ◆ Programmable Over-Voltage Protection (OVP2): The CS/ZCD pin provides a programmable OVP protection. Adjust the external ZCD resistors divider or add a Zener diode to adjust the protection threshold: if the CS/ZCD pin voltage exceeds 4.5 V (during the demagnetization time) for 4 consecutive switching cycles, the controller stops operating for the 4-s auto-recovery delay.
  - ◆ Cycle-by-cycle peak current limit: when the current sense voltage exceeds the internal threshold  $V_{ILIM}$ , the MOSFET is immediately turned off (cycle by cycle current limitation).
  - ◆ Winding or Output Diode Short-Circuit Protection (WODSCP): an additional comparator senses the CS signal and stops the controller if it exceeds  $150\% \times V_{ILIM}$  for 4 consecutive cycles. This feature can protect the converter if a winding is shorted or if the output diode is shorted or simply if the transformer saturates.
  - ◆ Auxiliary Short-circuit protection (AUX\_SCP): If the ZCD pin voltage remains low for a 90 ms time interval, the controller detects that the output or the ZCD pin is grounded and hence, stops pulsating until a 4 s time has elapsed.
  - ◆ Open LED protection: if the LED string is open, the output voltage will rise and lead the programmable over-voltage protection (OVP2) or the  $V_{CC}$  OVP to trip ( $V_{CC}$  OVP trips when the  $V_{CC}$  pin voltage exceeds the  $V_{CC(OVP)}$  threshold – 26.8 V typically). In such a case, the controller shuts down and waits 4 seconds before restarting switching operation.
  - ◆ Floating or Short Pin Detection: the circuit can detect most of these situations which helps pass safety tests.

**Constant Current Control**

The NCL30288 embeds an analog/digital block to control the power factor and regulate the output current by monitoring the ZCD,  $V_S$  and CS pin voltages (signals ZCD,

$V_S$  and  $V_{CS}$  of Figure 4). This circuitry generates the current setpoint ( $V_{CONTROL}$ ) and compares it to the current sense signal ( $V_{CS}$ ) to dictate the MOSFET turning off event when  $V_{CS}$  exceeds  $V_{CONTROL}$ .

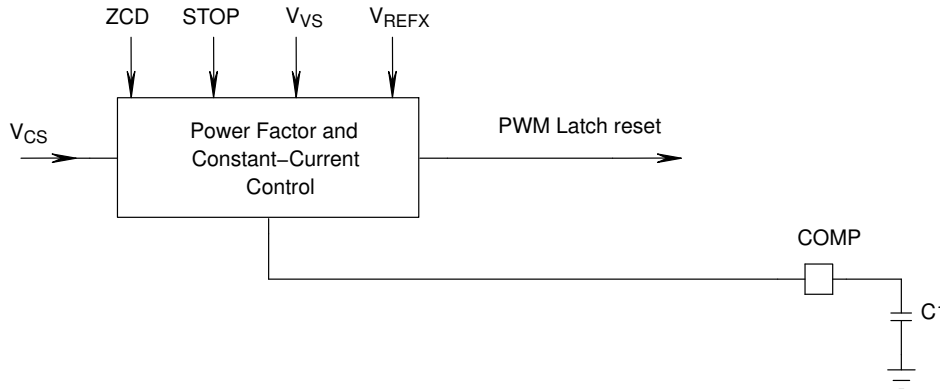

**Figure 4. Power Factor and Constant-Current Control**

As illustrated in Figure 4, the  $V_S$  pin provides the sinusoidal reference necessary for shaping the input current. The obtained current reference is further modulated so that when averaged over a half-line period, it is equal to the output current reference ( $V_{REFX}$ ). This averaging process is made by an internal Operational Trans-conductance Amplifier (OTA) and the capacitor connected to the COMP pin (C1 of Figure 4). Typical COMP capacitance is 1  $\mu$ F and should not be less than 470 nF to ensure stability. The COMP ripple does not affect the power factor performance as the circuit digitally eliminates it when generating the current setpoint.

If the  $V_S$  pin properly conveys the sinusoidal shape, power factor will be close to unity and the Total Harmonic Distortion (THD) will be low. In any case, the output current will be well regulated following the equation below:

$$I_{out} = \frac{V_{REF}}{2 N_{PS} R_{sense}} \quad (\text{eq. 1})$$

Where:

- $N_{PS}$  is the secondary to primary transformer turns  
 $N_{PS} = N_S / N_P$
- $R_{sense}$  is the current sense resistor (see Figure 1).
- $V_{REF}$  is the output current internal reference (200 mV).

Whenever a major fault is detected which forces the auto-recovery mode, the COMP pin is grounded for the 4-s interruption. This is also the case if one of these situations is detected: brown-out, UVLO, TSD fault. This ensures a clean start-up when the circuit resumes operation.

**Start-up Sequence**

Generally an LED lamp is expected to emit light in < 1 s and typically within 500 ms. The start-up phase consists of the time to charge the  $V_{CC}$  capacitor, to begin switching and the time to charge the output capacitor until sufficient current flows into the LED string. To speed-up this phase, the following characteristics define the start-up sequence:

- The COMP pin is grounded when the circuit is off. The average COMP voltage needs to exceed the  $V_S$  pin peak value to have the LED current properly regulated (whatever the current target is). To speed-up the COMP capacitance charge and shorten the start-up phase, an internal 80  $\mu$ A current source adds to the OTA sourced current (60  $\mu$ A max typically) to charge up the COMP capacitance. The 80  $\mu$ A current source remains on until the OTA starts to sink current as a result of the COMP pin voltage sufficient rise. At that moment, the COMP pin being near its steady-state value, only the OTA drives the COMP pin.
- If the load is shorted, the circuit will operate in hiccup mode with  $V_{CC}$  oscillating between  $V_{CC(off)}$  and  $V_{CC(on)}$  until the Auxiliary Short Circuit Protection, AUX\_SCP, forces the 4 s auto-recovery delay to reduce the operation duty-ratio (AUX\_SCP trips if the ZCD pin voltage does not exceed 1 V within a 90 ms active period of time thus indicating a short to ground of the ZCD pin or an excessive load preventing the output voltage from rising). Figure 5 illustrates a start-up sequence with the output shorted to ground.

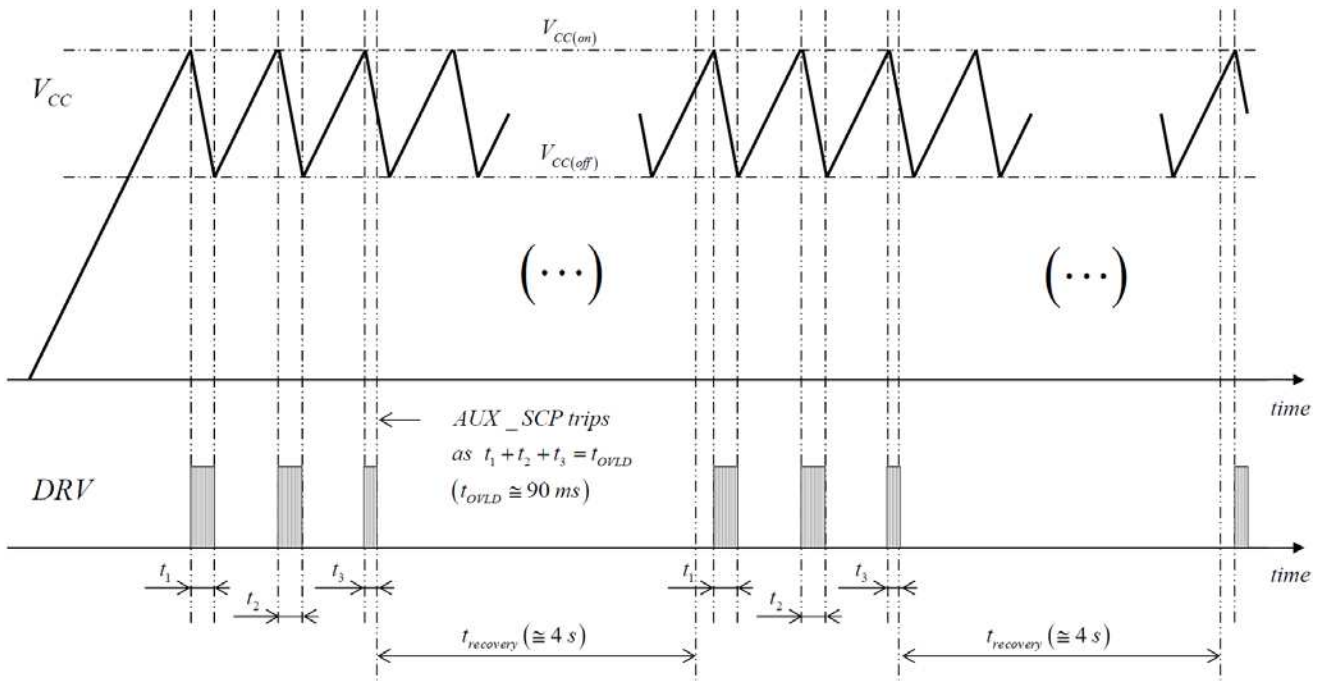

Figure 5. Start-up Sequence in a Load Short-circuit Situation

**Zero Crossing Detection Block**

The CS/ZCD pin detects when the drain-source voltage of the power MOSFET reaches a valley by crossing down the 55 mV internal threshold and initiates a new DRV pulse at that moment. At startup and in overload conditions, the ZCD comparator may not be able to detect the demagnetization signal. To allow a new DRV pulse to occur, the NCL30288 features a watchdog timer which initiates a DRV pulse if the CS/ZCD pin voltage does not trig the ZCD comparator for the watchdog time. The watchdog duration is typically 55  $\mu$ s at low line. It increases to 62  $\mu$ s when the line range is detected (see next section).

As detailed in next section, the NCL30288 operates in QR mode at low line and at valley 2 in high-line conditions. If the auxiliary winding free oscillations are extremely damped, the ZCD comparator may not be able to detect the second valley as necessary at high line. To overcome this high-line situation, the NCL30288 features a time-out circuit to initiate a DRV pulse if once the demagnetization is detected, the CS/ZCD pin voltage stays below the ZCD comparator internal threshold for about 7.3  $\mu$ s. Hence, the time-out acts as a substitute clock for valley-2 detection.

In other words:

- The timeout timer initiates a DRV pulse at high line if valley 1 is detected but valley 2 cannot be detected.
- The watchdog timer prevents the circuit from keeping permanently off if no demagnetization signal can be detected (e.g. at startup).

Whenever the controller enters operation (cold startup, restart after a failure to startup at the first attempt or

operation recovery after a fault), the ZCD blanking time is  $t_{ZCD(blank2)}$  (3  $\mu$ s typically) and keeps this value until the ZCD signal is high enough to be detected by the ZCD comparator (higher than  $V_{ZCD(rising)}$ , 90 mV typically). At that moment, the ZCD blanking time recovers its nominal level ( $t_{ZCD(blank1)} = 1.5\ \mu$ s, typically).

If the ZCD pin or the auxiliary winding happen to be shorted, the watchdog function would normally make the controller keep switching and hence lead to improper LED current regulation. The “AUX\_SCP” protection prevents such a stressful operation: a timer starts counting which is only reset when the ZCD voltage exceeds the  $V_{ZCD(short)}$  threshold (1 V typically). If this timer reaches 90 ms (no ZCD voltage pulse having exceeded  $V_{ZCD(short)}$  for this time period), the controller detects a fault and stops operation for 4 seconds.

The CS/ZCD pin is grounded for 325 ns (time  $T_1$  of the parametric table) when the drive turns low. This prevents a possible CS residual voltage to be taken into account by the ZCD comparator, which could otherwise occur in particular if a filtering capacitor was added to the pin. Similarly, the CS/ZCD pin is “reset” when the drive turns high. Practically, the pin is grounded for the 175 ns  $t_{BCS}$  time (Leading Edge Blanking Duration for  $V_{CS(stop)}$ ) to in this case, avoid that a  $V_{AUX}$  remaining voltage alters the current sense block operation.

**For an optimal operation, the maximum ZCD level should be maintained below 5 V to stay safely below the built in clamping voltage of the pin.**

**Line Range Detection**

As sketched in Figure 6, this circuit detects the low-line range if the  $V_S$  pin remains below the  $V_{LL}$  threshold (1.9 V typical) for more than the 25 ms blanking time. The high-line range is detected (“HL” of Figure 6 is high) as

soon as the  $V_S$  pin voltage exceeds  $V_{HL}$  (2.0 V typical). These levels roughly correspond to 152 V rms and 160 V rms line voltages if the external resistors divider applied to the  $V_S$  pin is designed to provide a 1 V peak value at 80 V rms.

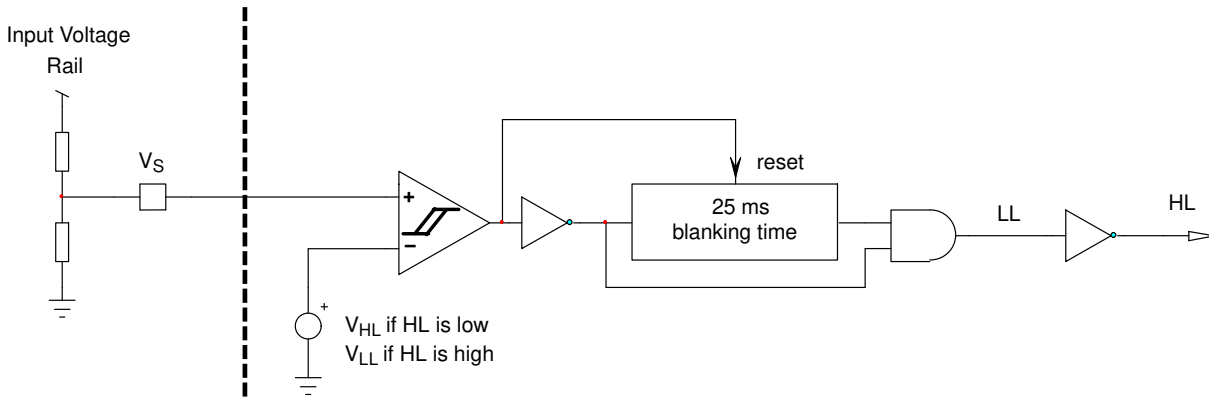

**Figure 6. Line Range Detection Circuitry**

In the low-line range, conduction losses are generally dominant. Adding a dead-time would further increase these losses by forcing increased switching current. In high-line conditions, switching losses generally are the most critical. It is thus efficient to skip one valley to lower the switching frequency. Hence, under normal operation, the NCL30288

optimizes the efficiency over the line range by turning on the MOSFET at the first valley in low-line conditions and at the second valley in the high-line case. This is illustrated by Figure 7 that sketches the MOSFET Drain-source voltage in both cases.



**Figure 7. Quasi-resonant Mode in Low Line (left), Turn on at Valley 2 when in High Line (right)**

In addition, the gain of the current control block is divided by two when the high-line range is detected. This allows for an optimal resolution of the output current over the line range.

**Line Feedforward**

The NCL30288 computes the current setpoint ( $V_{control}$ ) for power factor correction and proper regulation of the LED

current. Now, the MOSFET cannot turn off at the very moment when the current-sense voltage exceeds  $V_{control}$ . There actually exists a propagation delay for which the primary current keeps rising. As a result, the primary current does not exactly peak to the expected ( $V_{control} / R_{SENSE}$ ) value but to a higher level. The NCL30288 features the line feedforward function to compensate for this effect.

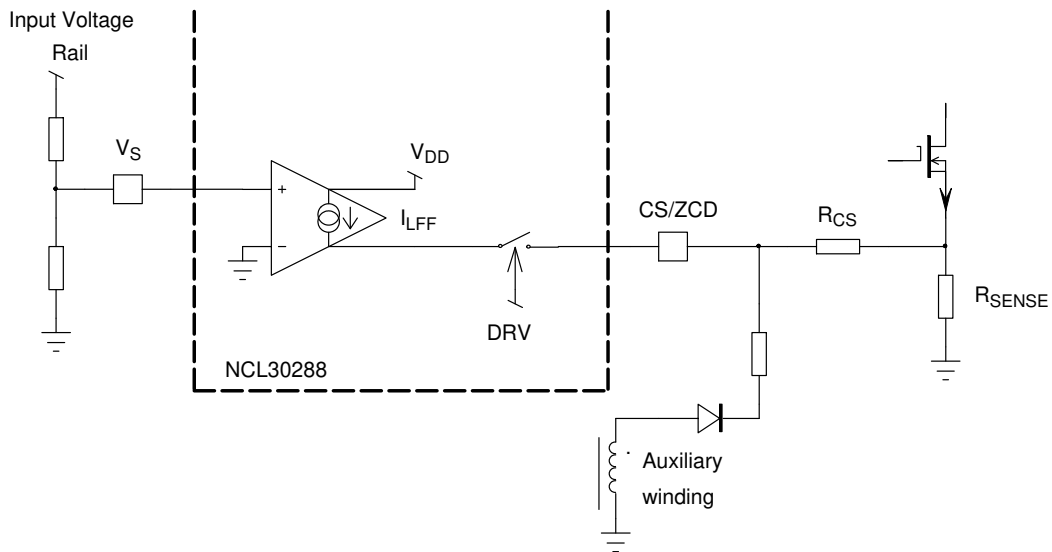

Figure 8. Line Feed-Forward Schematic

As illustrated by Figure 8, the input voltage is sensed by the  $V_S$  pin and converted into a current ( $I_{LFF}$ ) which is sourced by the CS/ZCD pin during the MOSFET on-time. An external resistor ( $R_{CS}$ ) being placed between the MOSFET current sense resistor ( $R_{SENSE}$ ) and the CS pin, this current produces a voltage offset proportional to the input voltage which is added to the CS signal. This effectively compensates for the over-currents caused by the switching delays. For optimal output current accuracy over the line range,  $R_{CS}$  must thus be optimized as a function of the application switching delays.

### Protections

The circuit incorporates a large variety of protections to make the LED driver very rugged. Among them, we can list:

- Output Short Circuit Situation

An overload fault is detected if the CS/ZCD pin voltage remains below  $V_{ZCD(short)}$  for 90 ms. The signal is compared to  $V_{ZCD(short)}$  during the off time after the ZCD blanking time is elapsed. In such a situation, the circuit stops generating pulses until the 4 s delay auto-recovery time has elapsed.

- Winding or Output Diode Short Circuit Protection(WODSCP)

If a transformer winding happens to be shorted, the primary inductance will collapse leading the current to ramp up in a very abrupt manner. The  $V_{ILIM}$  comparator (current limitation threshold) will trip to open the MOSFET and eventually stop the current rise. However, because of the abnormally steep slope of the current, internal propagation delays and the MOSFET turn-off time will make possible the current rise up to 50% or more of the nominal maximum value set by  $V_{ILIM}$ . As illustrated in Figure 9, the circuit uses this current overshoot to detect a winding short circuit. The leading edge blanking (LEB) time for short circuit protection is significantly shorter than the LEB time for cycle-by-cycle protection (LEB2 lasts for  $T_{BCS} - 175$  ns typically – while LEB1 lasts for  $T_{LEB} - 275$  ns typically). Practically, if four consecutive switching periods lead the CS pin voltage to exceed  $V_{CS(stop)}$  ( $V_{CS(stop)} = 150\% * V_{ILIM}$ ), the controller enters auto-recovery mode (4 s operation interruption between active bursts). Similarly, this function can also protect the power supply if the output diode is shorted or if the transformer simply saturates.

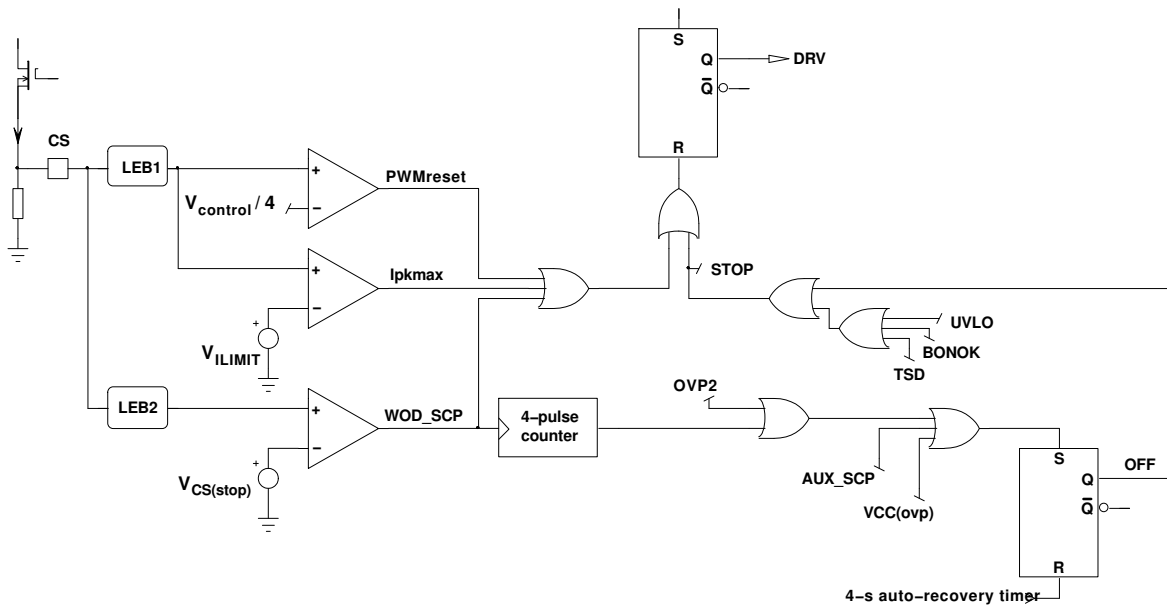

Figure 9. Winding Short Circuit Protection, Max. Peak Current Limit Circuits

- V<sub>CC</sub> Over Voltage Protection**  
 The circuit stops generating pulses if V<sub>CC</sub> exceeds V<sub>CC(OVP)</sub> and enters auto-recovery mode. This feature protects the circuit if the output LED string happens to open or is disconnected.
- Programmable Over Voltage Protection (OVP2)**  
 The ZCD signal is compared to an internal 4.5 V threshold. If V<sub>ZCD</sub> exceeds this threshold for more than 1 μs (after the ZCD blanking time), an OVP event is detected. If this happens for 4 consecutive switching cycles, an OVP fault is detected and the system enters auto-recovery mode.
- Cycle-by-Cycle Current Limit**  
 When the current sense voltage exceeds the internal threshold V<sub>ILIM</sub>, the MOSFET is turned off for the rest of the switching cycle.

- Brown-Out Protection**  
 The NCL30288 prevents operation when the line voltage is too low for proper operation. As sketched in Figure 10, the circuit detects a brown-out situation (BONOK is high) if the V<sub>S</sub> pin remains below the V<sub>BO(off)</sub> threshold (0.9 V typical) for more than the 25 ms blanking time. In this case, the controller stops operating. Operation resumes as soon as the V<sub>S</sub> pin voltage exceeds V<sub>BO(on)</sub> (1.0 V typical) and V<sub>CC</sub> is higher than V<sub>CC(on)</sub>. To ease recovery, the circuit overrides the V<sub>CC</sub> normal sequence (no need for V<sub>CC</sub> cycling down below V<sub>CC(off)</sub>). Instead, its consumption immediately reduces to I<sub>CC(start)</sub> so that V<sub>CC</sub> rapidly charges up to V<sub>CC(on)</sub>. Once done, the circuit re-starts operating.

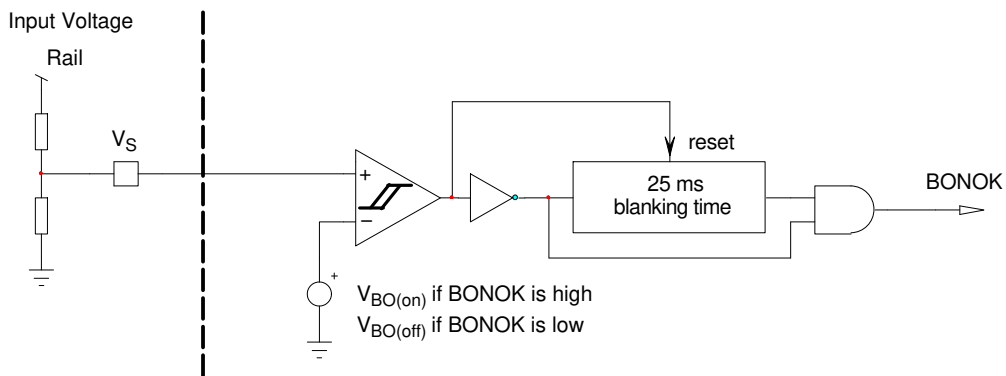

Figure 10. Brown-out Protection Circuit

## NCL30288

- Die Over Temperature (TSD)  
The circuit stops operating if the junction temperature ( $T_J$ ) exceeds 150°C typically. The controller remains off until  $T_J$  goes below nearly 100°C.
- Pin connection faults  
The circuit addresses most pin connection fault cases. In particular, the circuit detects the CS pin short to ground situations by sensing the CS/ZCD pin impedance every time it starts-up and after DRV pulses

are terminated by the 36  $\mu$ s maximum on-time. If the measured impedance does not exceed 170  $\Omega$  typically, the circuit stops operating. In practice, it is recommended to place a minimum of 500  $\Omega$  in series between the CS pin and the current sense resistor to take into account possible parametric deviations.

More generally, pin incorrect connection situations (open, grounded, shorted to adjacent pin) are covered by ANDxxxx.

# NCL30288

## PACKAGE OUTLINE

TSOP-6  
CASE 318G-02  
ISSUE V

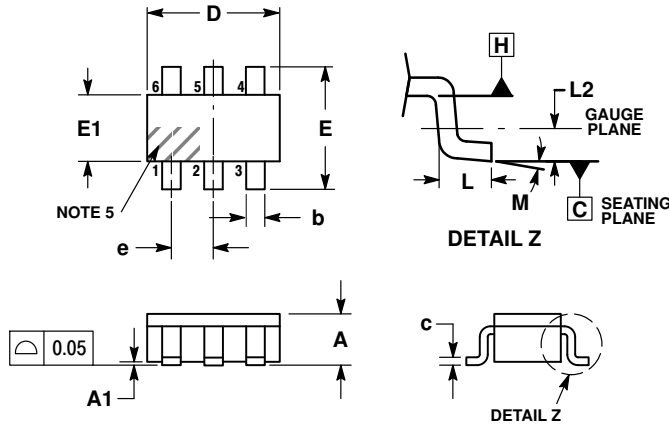

**NOTES:**

1. DIMENSIONING AND TOLERANCING PER ASME Y14.5M, 1994.
2. CONTROLLING DIMENSION: MILLIMETERS.
3. MAXIMUM LEAD THICKNESS INCLUDES LEAD FINISH. MINIMUM LEAD THICKNESS IS THE MINIMUM THICKNESS OF BASE MATERIAL.
4. DIMENSIONS D AND E1 DO NOT INCLUDE MOLD FLASH, PROTRUSIONS, OR GATE BURRS. MOLD FLASH, PROTRUSIONS, OR GATE BURRS SHALL NOT EXCEED 0.15 PER SIDE. DIMENSIONS D AND E1 ARE DETERMINED AT DATUM H.
5. PIN ONE INDICATOR MUST BE LOCATED IN THE INDICATED ZONE.

DIM	MILLIMETERS		
	MIN	NOM	MAX
A	0.90	1.00	1.10
A1	0.01	0.06	0.10
b	0.25	0.38	0.50
c	0.10	0.18	0.26
D	2.90	3.00	3.10
E	2.50	2.75	3.00
E1	1.30	1.50	1.70
e	0.85	0.95	1.05
L	0.20	0.40	0.60
L2	0.25 BSC		
M	-		

### RECOMMENDED SOLDERING FOOTPRINT\*

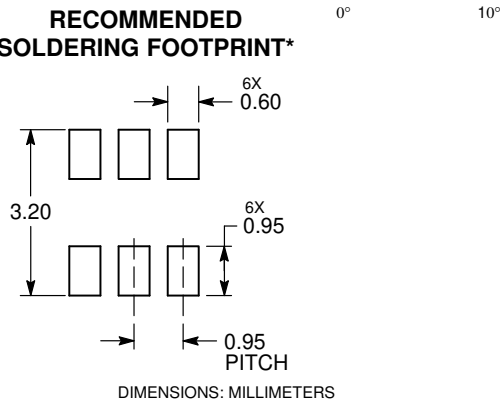

DIMENSIONS: MILLIMETERS

\*For additional information on our Pb-Free strategy and soldering details, please download the ON Semiconductor Soldering and Mounting Techniques Reference Manual, SOLDERRM/D.

ON Semiconductor and are trademarks of Semiconductor Components Industries, LLC dba ON Semiconductor or its subsidiaries in the United States and/or other countries. ON Semiconductor owns the rights to a number of patents, trademarks, copyrights, trade secrets, and other intellectual property. A listing of ON Semiconductor's product/patent coverage may be accessed at [www.onsemi.com/site/pdf/Patent-Marking.pdf](http://www.onsemi.com/site/pdf/Patent-Marking.pdf). ON Semiconductor reserves the right to make changes without further notice to any products herein. ON Semiconductor makes no warranty, representation or guarantee regarding the suitability of its products for any particular purpose, nor does ON Semiconductor assume any liability arising out of the application or use of any product or circuit, and specifically disclaims any and all liability, including without limitation special, consequential or incidental damages. Buyer is responsible for its products and applications using ON Semiconductor products, including compliance with all laws, regulations and safety requirements or standards, regardless of any support or applications information provided by ON Semiconductor. "Typical" parameters which may be provided in ON Semiconductor data sheets and/or specifications can and do vary in different applications and actual performance may vary over time. All operating parameters, including "Typicals" must be validated for each customer application by customer's technical experts. ON Semiconductor does not convey any license under its patent rights nor the rights of others. ON Semiconductor products are not designed, intended, or authorized for use as a critical component in life support systems or any FDA Class 3 medical devices or medical devices with a same or similar classification in a foreign jurisdiction or any devices intended for implantation in the human body. Should Buyer purchase or use ON Semiconductor products for any such unintended or unauthorized application, Buyer shall indemnify and hold ON Semiconductor and its officers, employees, subsidiaries, affiliates, and distributors harmless against all claims, costs, damages, and expenses, and reasonable attorney fees arising out of, directly or indirectly, any claim of personal injury or death associated with such unintended or unauthorized use, even if such claim alleges that ON Semiconductor was negligent regarding the design or manufacture of the part. ON Semiconductor is an Equal Opportunity/Affirmative Action Employer. This literature is subject to all applicable copyright laws and is not for resale in any manner.

### PUBLICATION ORDERING INFORMATION

**LITERATURE FULFILLMENT:**

Literature Distribution Center for ON Semiconductor  
19521 E. 32nd Pkwy, Aurora, Colorado 80011 USA  
Phone: 303-675-2175 or 800-344-3860 Toll Free USA/Canada  
Fax: 303-675-2176 or 800-344-3867 Toll Free USA/Canada  
Email: [orderlit@onsemi.com](mailto:orderlit@onsemi.com)

**N. American Technical Support:** 800-282-9855 Toll Free  
USA/Canada  
**Europe, Middle East and Africa Technical Support:**  
Phone: 421 33 790 2910  
**Japan Customer Focus Center**  
Phone: 81-3-5817-1050

**ON Semiconductor Website:** [www.onsemi.com](http://www.onsemi.com)

**Order Literature:** <http://www.onsemi.com/orderlit>

For additional information, please contact your local Sales Representative