



Chipsmall Limited consists of a professional team with an average of over 10 year of expertise in the distribution of electronic components. Based in Hongkong, we have already established firm and mutual-benefit business relationships with customers from,Europe,America and south Asia,supplying obsolete and hard-to-find components to meet their specific needs.

With the principle of “Quality Parts,Customers Priority,Honest Operation,and Considerate Service”,our business mainly focus on the distribution of electronic components. Line cards we deal with include Microchip,ALPS,ROHM,Xilinx,Pulse,ON,Everlight and Freescale. Main products comprise IC,Modules,Potentiometer,IC Socket,Relay,Connector.Our parts cover such applications as commercial,industrial, and automotives areas.

We are looking forward to setting up business relationship with you and hope to provide you with the best service and solution. Let us make a better world for our industry!



Contact us

Tel: +86-755-8981 8866 Fax: +86-755-8427 6832

Email & Skype: info@chipsmall.com Web: www.chipsmall.com

Address: A1208, Overseas Decoration Building, #122 Zhenhua RD., Futian, Shenzhen, China



NCN2411

4-Channel Differential 1:2 Mux/Demux Switch for PCI Express Gen2

The NCN2411 is a 4-Channel differential SPDT switch designed to route PCI Express Gen2 signals. When used in a PCI Express application, the switch can handle up to two PCIe lanes. Due to the ultra-low ON-state capacitance (2 pF typ) and resistance (7.5 Ω typ), this switch is ideal for switching high frequency signals up to a signal bit rate (BR) of 5 Gbps. This switch pinout is designed to be used in BTX form factor desktop PCs and is available in a space-saving 3.5x9x0.75 mm WQFN42 package.

Features

- V_{DD} Power Supply from 1.5 V to 2.0 V
- 4 Differential Channels 2:1 MUX/DEMUX
- Compatible with PCIe 2.0
- Data Rate: Supports 5 Gbps
- Low Crosstalk: -30 dB @ 3 GHz
- Low Bit-to-Bit Skew: 5 ps
- Low R_{ON} Resistance: 13 Ω max
- Low C_{ON} Capacitance: 2 pF
- Low Supply Current: 200 μ A
- Insertion Loss: -2 dB @ 3 GHz
- Space Saving, Small WQFN-42 Package
- This is a Pb-Free Device

Typical Applications

- Notebook Computer
- Desktop computer
- Server/Storage Area Network

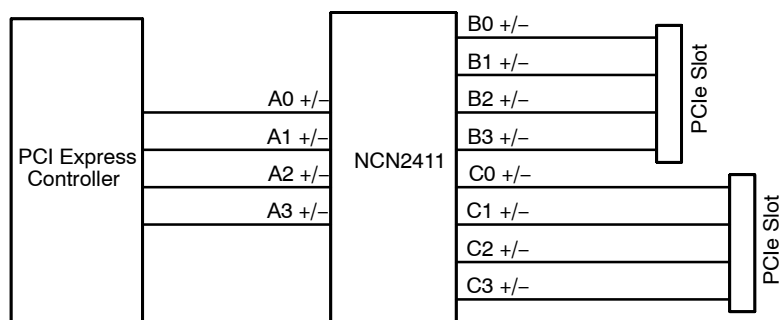
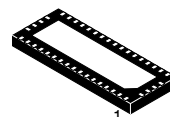

Figure 1. Application Schematic



ON Semiconductor®

<http://onsemi.com>



MARKING DIAGRAM

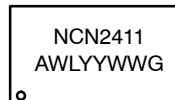

WQFN42
CASE 510AP

A = Assembly Location
WL = Wafer Lot
YY = Year
WW = Work Week
G = Pb-Free Package

ORDERING INFORMATION

Device	Package	Shipping†
NCN2411MTTWG	WQFN42 (Pb-Free)	2000 / Tape & Reel

†For information on tape and reel specifications, including part orientation and tape sizes, please refer to our Tape and Reel Packaging Specifications Brochure, BRD8011/D.

NCN2411

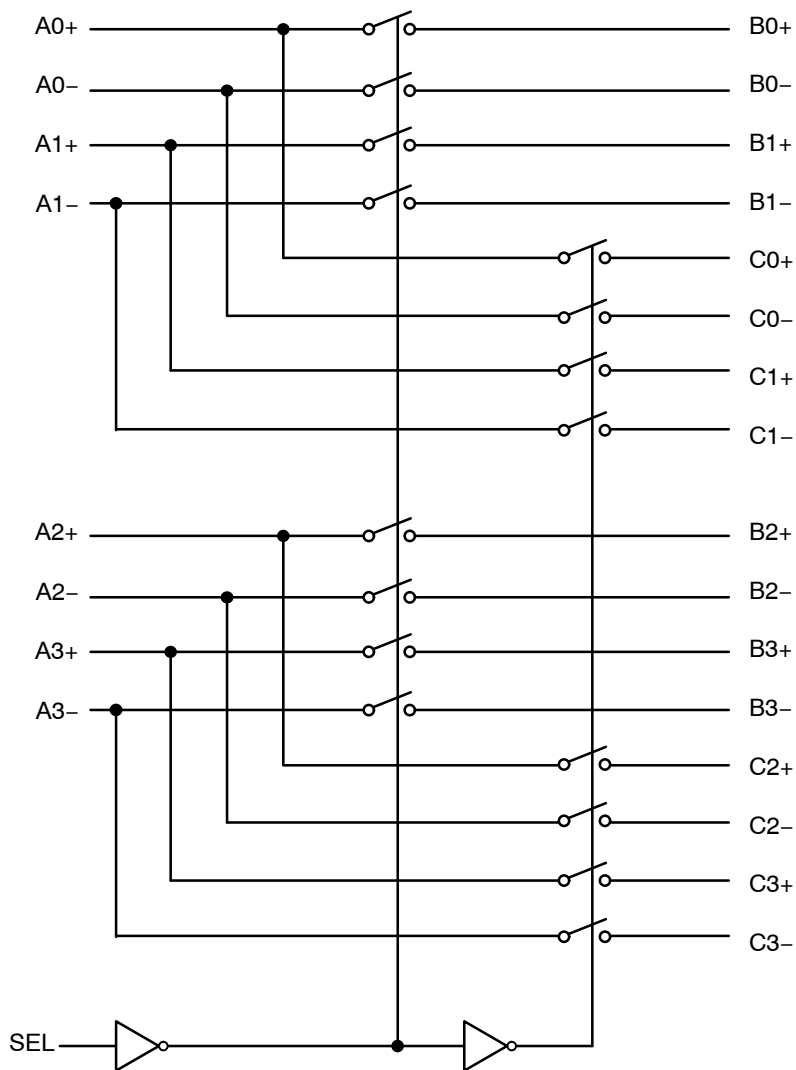
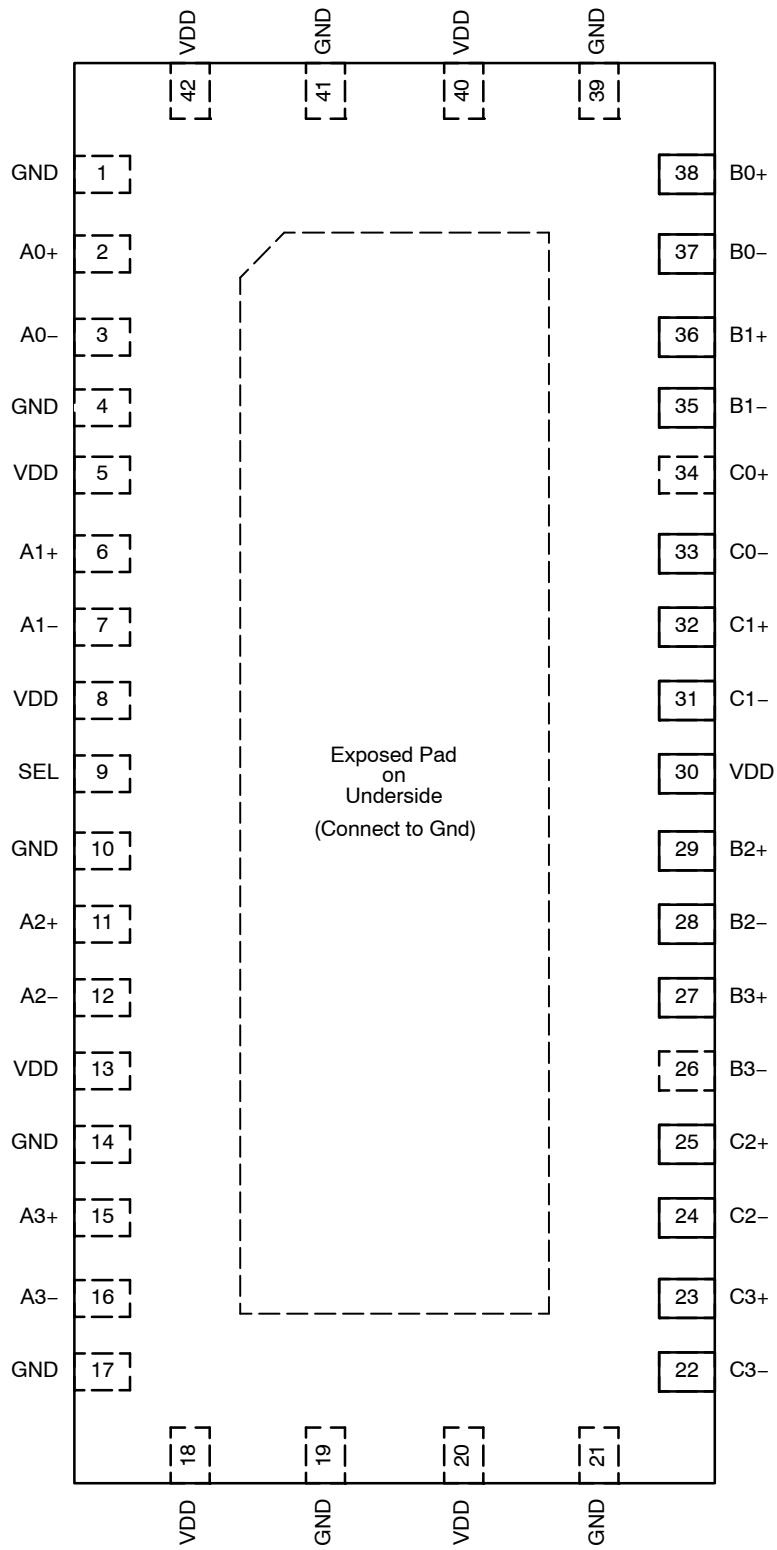

**Figure 2. NCN2411 Functional Block Diagram
(Top View)**

TRUTH TABLE

Function	SEL
A_N to B_N	L
A_N to C_N	H

NCN2411



**Figure 3. Pin Description
(Top View)**

NCN2411

PIN FUNCTION AND DESCRIPTION

Pin	Pin Name	Description
2, 3	A0+, A0-	Signal I/O, Channel 0, Port A
6, 7	A1+, A1-	Signal I/O, Channel 1, Port A
11, 12	A2+, A2-	Signal I/O, Channel 2, Port A
15, 16	A3+, A3-	Signal I/O, Channel 3, Port A
38, 37	B0+, B0-	Signal I/O, Channel 0, Port B
36, 35	B1+, B1-	Signal I/O, Channel 1, Port B
29, 28	B2+, B2-	Signal I/O, Channel 2, Port B
27, 26	B3+, B3-	Signal I/O, Channel 3, Port B
34, 33	C0+, C0-	Signal I/O, Channel 0, Port C
32, 31	C1+, C1-	Signal I/O, Channel 1, Port C
25, 24	C2+, C2-	Signal I/O, Channel 2, Port C
23, 22	C3+, C3-	Signal I/O, Channel 3, Port C
9	SEL	Operational Mode Select (When SEL = 0: A → B, When SEL = 1: A → C) Do not float this pin.
5, 8, 13, 18, 20, 30, 40, 42	VDD	DC Supply: 1.5 V to 2.0 V
1, 4, 10, 14, 17, 19, 21, 39, 41	GND	Power Ground
Exposed Pad	-	The exposed pad on the backside of package is internally connected to GND. Externally the pad should also be user-connected to GND.

MAXIMUM RATINGS

Parameter	Symbol	Rating	Units
Power Supply Voltage	V_{DD}	-0.5 to 2.5	V_{DC}
Input/Output Voltage Range of the Switch (A_N , B_N , C_N)	V_{IS}	-0.5 to V_{DD}	V_{DC}
Selection Pin Voltages	V_{SEL}	-0.5 to V_{DD}	V_{DC}
Continuous Current Through One Switch	I_{CC}	±120	mA
Maximum Junction Temperature (Note 1)	T_J	150	°C
Operating Ambient Temperature	T_A	-40 to +85	°C
Storage Temperature Range	T_{stg}	-65 to +150	°C
Thermal Resistance, Junction-to-Air	$R_{\theta JA}$	75	°C/W
Latch-up Current (Note 2)	I_{LU}	±100	mA
Human Body Model (HBM) ESD Rating (Note 3)	ESD HBM	7000	V
Machine Model (MM) ESD Rating (Note 3)	ESD MM	400	V
Moisture Sensitivity (Note 4)	MSL	Level 1	-

Stresses exceeding Maximum Ratings may damage the device. Maximum Ratings are stress ratings only. Functional operation above the Recommended Operating Conditions is not implied. Extended exposure to stresses above the Recommended Operating Conditions may affect device reliability.

1. Power dissipation must be considered to ensure maximum junction temperature (T_J) is not exceeded.
2. Latch up Current Maximum Rating: ±100 mA per JEDEC standard: JESD78.
3. This device series contains ESD protection and passes the following tests:
Human Body Model (HBM) ±7.0 kV per JEDEC standard: JESD22-A114 for all pins.
Machine Model (MM) ±400 V per JEDEC standard: JESD22-A115 for all pins.
4. Moisture Sensitivity Level (MSL): 1 per IPC/JEDEC standard: J-STD-020A.

NCN2411

DC ELECTRICAL CHARACTERISTICS OVER OPERATING RANGE ($T_A = -40^{\circ}\text{C}$ to $+85^{\circ}\text{C}$, $V_{DD} = 1.5\text{ V}$ to 2.0 V , $\text{GND} = 0\text{V}$)

Symbol	Pins	Parameters	Conditions (Note 5)	Min.	Typ (Note 6)	Max.	Units
--------	------	------------	---------------------	------	--------------	------	-------

POWER SUPPLY

V_{DD}	V_{DD} , GND	Supply Voltage Range	With respect to GND	1.5	1.8	2.0	V
I_{DD}	V_{DD} , GND	Quiescent Supply Current	$V_{DD} = 2\text{ V}$, $V_{SEL} = \text{GND}$ or V_{DD}		200	300	μA

DATA SWITCH PERFORMANCE

V_{IS}	A_N , B_N , C_N	Data Input/Output Voltage Range		0		1.2	V
R_{ON}	B_N	On Resistance (B_N)	$V_{DD} = 1.5\text{ V}$, $V_{IS} = 0\text{ V}$ to 1.2 V , $I_{IS} = 15\text{ mA}$		7.5	13	Ω
R_{ON}	C_N	On Resistance (C_N)	$V_{DD} = 1.5\text{ V}$, $V_{IS} = 0\text{ V}$ to 1.2 V , $I_{IS} = 15\text{ mA}$		8.0	13	Ω
$R_{ON(\text{flat})}$	B_N	On Resistance Flatness	$V_{DD} = 1.5\text{ V}$, $V_{IS} = 0\text{ V}$ to 1.2 V , $I_{IS} = 15\text{ mA}$ (Note 7)		0.1	1.24	Ω
$R_{ON(\text{flat})}$	C_N	On Resistance Flatness	$V_{DD} = 1.5\text{ V}$, $V_{IS} = 0\text{ V}$ to 1.2 V , $I_{IS} = 15\text{ mA}$ (Note 7)		0.1	1.24	Ω
ΔR_{ON}	B_N	On Resistance Matching(B_N)	$V_{DD} = 1.5\text{ V}$, $V_{IS} = 0\text{ V}$, $I_{IS} = 15\text{ mA}$ (Note 7)			0.35	Ω
ΔR_{ON}	C_N	On Resistance Matching(C_N)	$V_{DD} = 1.5\text{ V}$, $V_{IS} = 0\text{ V}$, $I_{IS} = 15\text{ mA}$ (Note 7)			0.35	Ω
C_{ON}	A_N to B_N , A_N to C_N	On Capacitance	$f = 1\text{ MHz}$, Switch On, Open Output		2.0		pF
C_{OFF}	A_N to B_N , A_N to C_N	Off Capacitance	$f = 1\text{ MHz}$, Switch Off		1.5		pF
I_{ON}	A_N to B_N , A_N to C_N	On Leakage Current	$V_{DD} = 2\text{ V}$, $V_{AN} = 0\text{ V}$, 1.2 V , Switch On to B_N/C_N , B_N/C_N pins are unconnected	-1		+1	μA
I_{OFF}	A_N to B_N , A_N to C_N	Off Leakage Current	$V_{DD} = 2\text{ V}$, $V_{AN} = 0\text{ V}$, 1.2 V , Switch Off to B_N/C_N , $V_{BN}/V_{CN} = 1.2\text{ V}$, 0 V	-1		+1	μA

LOGIC INPUT CHARACTERISTICS (SEL Pin)

V_{IH}	SEL	Input HIGH Voltage	(Note 7)	$0.65 \times V_{DD}$		V_{DD}	V
V_{IL}	SEL	Input LOW Voltage	(Note 7)	0		$0.35 \times V_{DD}$	V
V_{IK}	SEL	Clamp Diode Voltage	$V_{DD} = \text{Max}$, $I_{SEL} = -18\text{ mA}$		-0.7	-1.2	V
I_{IH}	SEL	Input HIGH Current	$V_{DD} = \text{Max}$, $V_{SEL} = V_{DD}$			± 5	μA
I_{IL}	SEL	Input LOW Current	$V_{DD} = \text{Max}$, $V_{SEL} = \text{GND}$			± 5	μA

SWITCHING CHARACTERISTICS

$t_{SELO\text{N}}$	SEL, A_N , B_N/C_N	Line Enable Time	SEL to A_N , B_N , C_N $R_L = 50\ \Omega$, $C_L = 20\ \text{pF}$		8.0		ns
$t_{SELO\text{F}}$	SEL, A_N , B_N/C_N	Line Disable Time	SEL to A_N , B_N , C_N $R_L = 50\ \Omega$, $C_L = 20\ \text{pF}$		5.0		ns
t_{b-b}	A_N , B_N/C_N	Bit-to-bit skew	Within the same differential pair		9.0		ps
t_{ch-ch}	A_N , B_N	Channel-to channel skew	Maximum skew between all channels		50		ps

5. For Max. or Min. conditions, use appropriate value specified under Electrical Characteristics for the applicable device type.

6. Typical values are at $V_{DD} = 1.8\text{ V}$, $T_A = 25^{\circ}\text{C}$ ambient and maximum loading.

7. Guaranteed by design and/or characterization.

NCN2411

DC ELECTRICAL CHARACTERISTICS OVER OPERATING RANGE ($T_A = -40^{\circ}\text{C}$ to $+85^{\circ}\text{C}$, $V_{DD} = 1.5\text{ V}$ to 2.0 V , $\text{GND} = 0\text{V}$)

Symbol	Pins	Parameters	Conditions (Note 5)	Min.	Typ (Note 6)	Max.	Units
--------	------	------------	---------------------	------	-----------------	------	-------

DYNAMIC ELECTRICAL CHARACTERISTICS OVER OPERATING RANGE

BR	A_N to B_N , A_N to C_N	Signal Bit Rate			5.0		Gbps
D _{IL}	A_N to B_N , A_N to C_N	Differential Insertion Loss	f = 3 GHz		-2.0		dB
			f = 100 MHz		-0.7		dB
D _{CTK}	A_N , B_N , C_N	Differential Crosstalk	f = 3 GHz		-30		dB
			f = 100 MHz		-58		dB
D _{ISO}	A_N to B_N , A_N to C_N	Differential Off Isolation	f = 3 GHz		-23		dB
			f = 100 MHz		-58		dB
D _{RL}	A_N to B_N , A_N to C_N	Differential Return Loss	f = 3 GHz		-6.0		dB
			f = 100 MHz		-22		dB

5. For Max. or Min. conditions, use appropriate value specified under Electrical Characteristics for the applicable device type.

6. Typical values are at $V_{DD} = 1.8\text{ V}$, $T_A = 25^{\circ}\text{C}$ ambient and maximum loading.

7. Guaranteed by design and/or characterization.

TYPICAL OPERATING CHARACTERISTICS

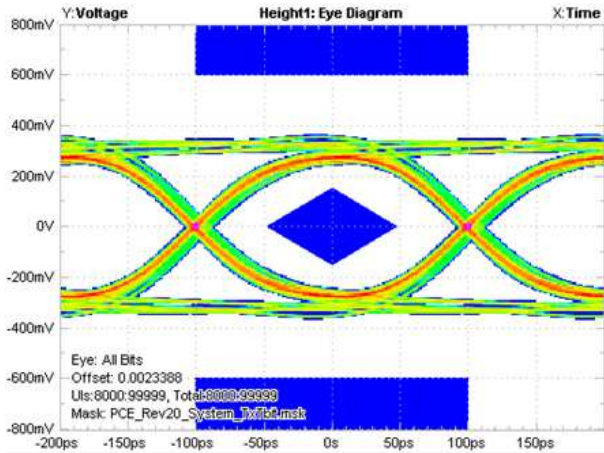

Figure 4. PCI Express Eye Diagram at 5 Gbps, 800 mVpp Differential Swing (Minimum Case)

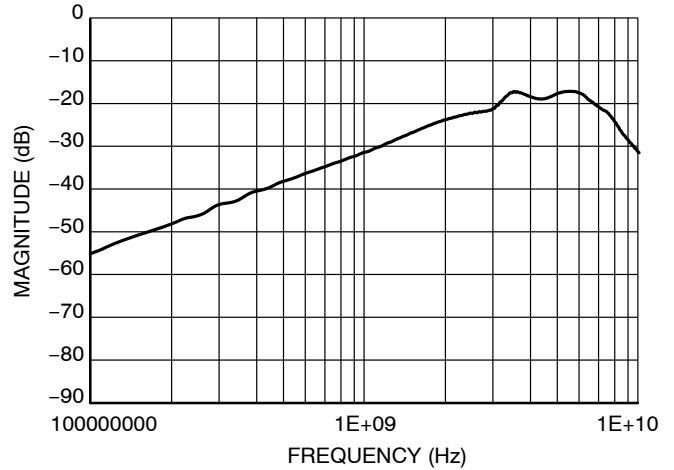

Figure 5. Differential Off Isolation

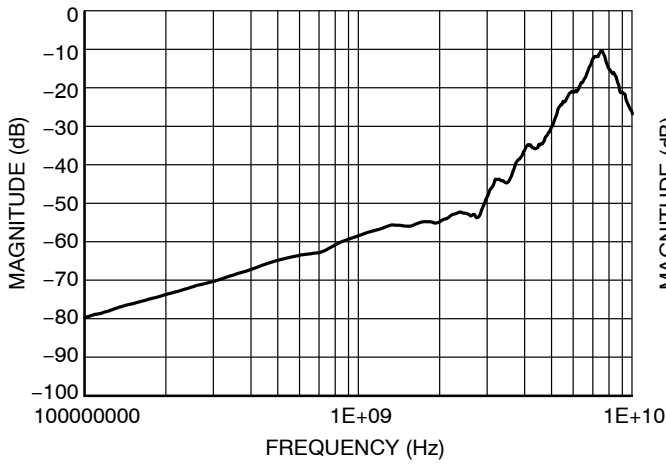

Figure 6. Differential Crosstalk

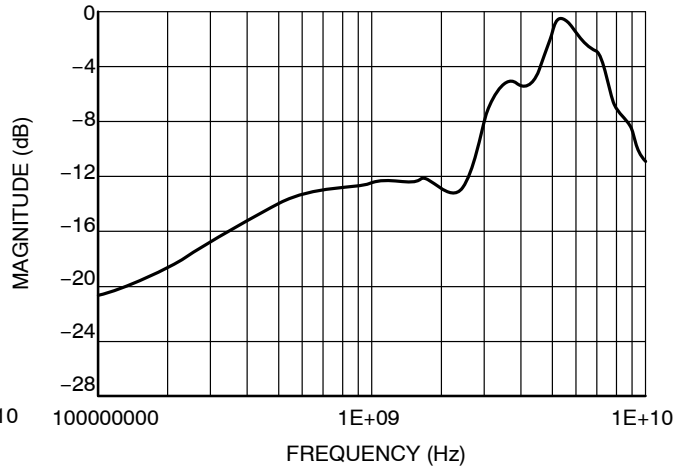

Figure 7. Differential Return Loss

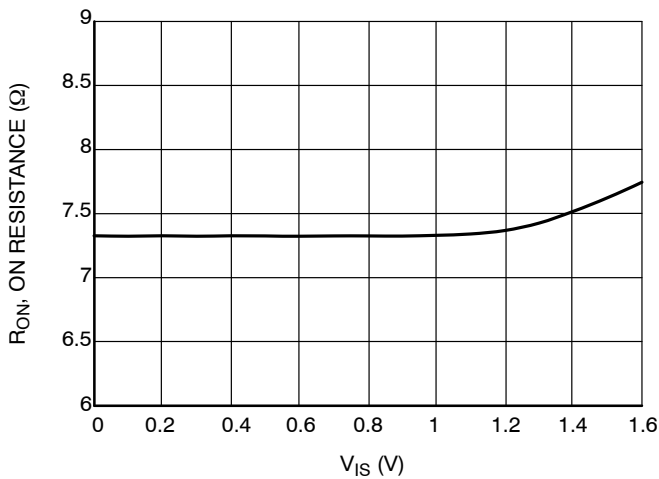

Figure 8. RON vs. VIS

PARAMETER MEASUREMENT INFORMATION

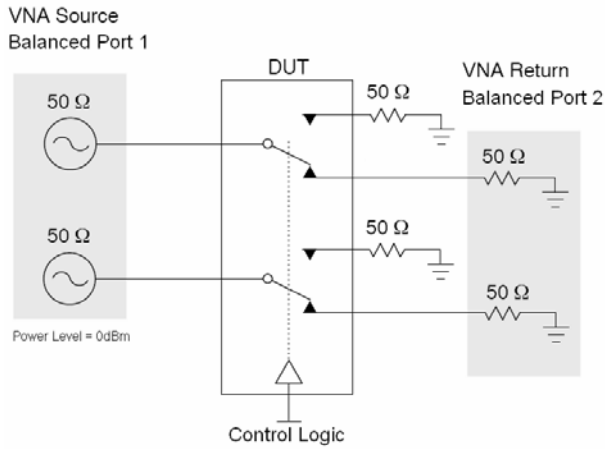

Figure 9. Differential Insertion Loss (S_{DD21}) and Differential Return Loss (S_{DD11})

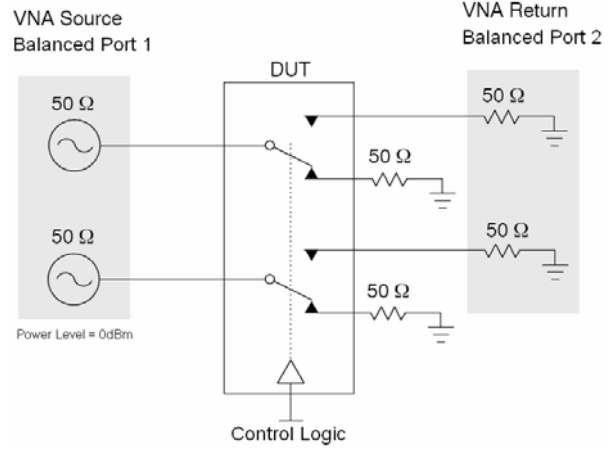

Figure 10. Differential Off Isolation (S_{DD21})

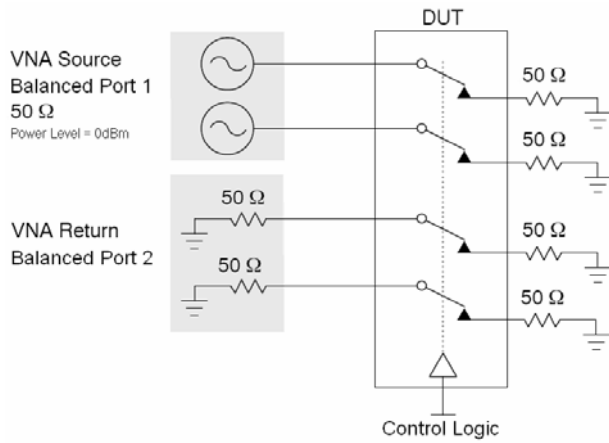

Figure 11. Differential Crosstalk (S_{DD21})

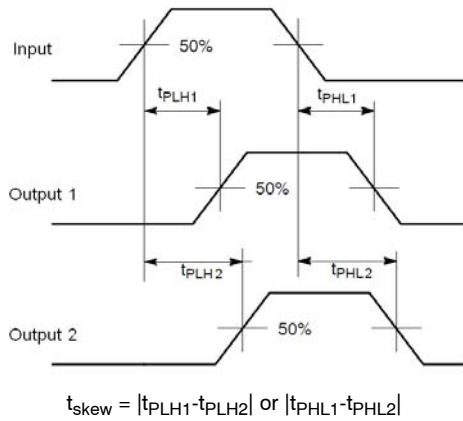

Figure 12. Bit-to-Bit and Channel-to-Channel Skew

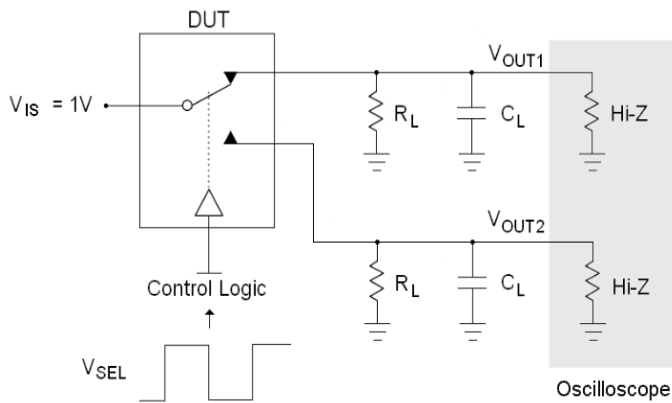

Figure 13. t_{ON} and t_{OFF}

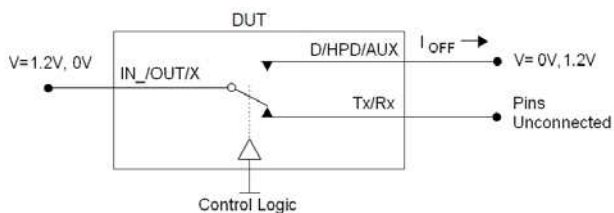
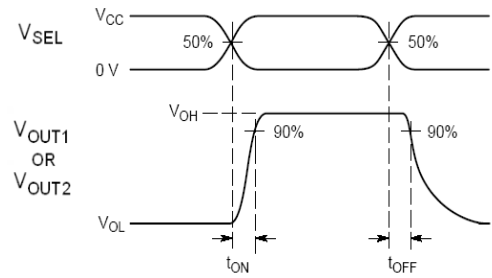

Figure 14. Off State Leakage

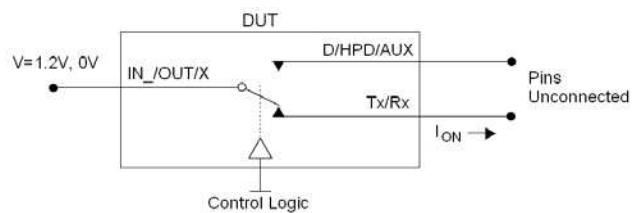
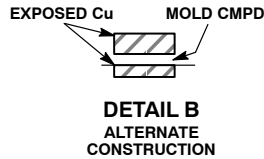
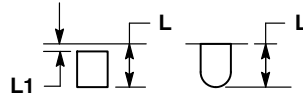
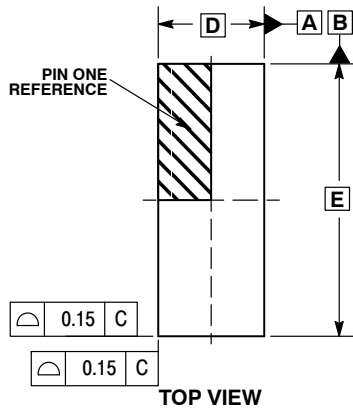

Figure 15. On State Leakage

NCN2411

PACKAGE DIMENSIONS

WQFN42 3.5x9, 0.5P
CASE 510AP-01
ISSUE O



NOTES:

1. DIMENSIONING AND TOLERANCING PER ASME Y14.5M, 1994.
2. CONTROLLING DIMENSION: MILLIMETERS.
3. DIMENSION b APPLIES TO PLATED TERMINAL AND IS MEASURED BETWEEN 0.15 AND 0.30 MM FROM TERMINAL TIP.
4. COPLANARITY APPLIES TO THE EXPOSED PAD AS WELL AS THE TERMINALS.

DIM	MILLIMETERS	
	MIN	MAX
A	0.70	0.80
A1	0.00	0.05
A3	0.20	REF
b	0.20	0.30
D	3.50 BSC	
D2	1.95	2.15
E	9.00 BSC	
E2	7.45	7.65
e	0.50 BSC	
K	0.20	---
L	0.30	0.50
L1	0.00	0.15

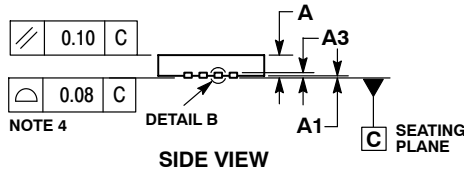

RECOMMENDED MOUNTING FOOTPRINT*

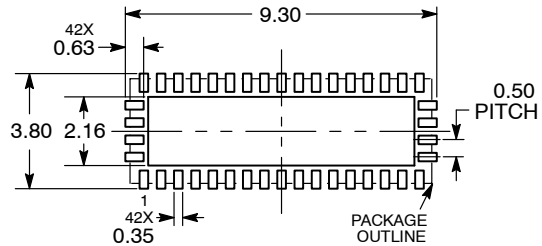

DIMENSIONS: MILLIMETERS

*For additional information on our Pb-Free strategy and soldering details, please download the ON Semiconductor Soldering and Mounting Techniques Reference Manual, SOLDERRM/D.

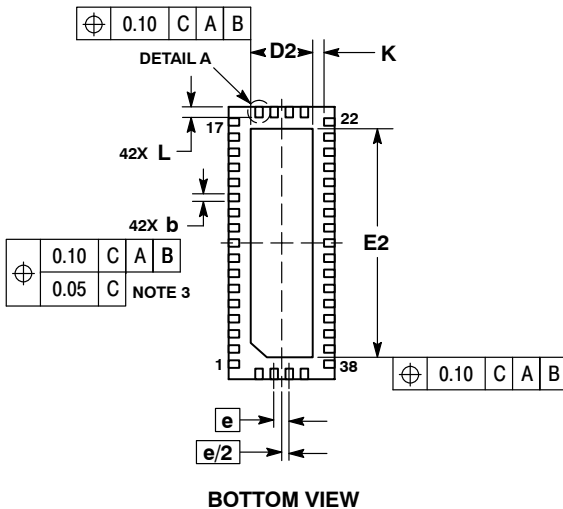

ON Semiconductor and are registered trademarks of Semiconductor Components Industries, LLC (SCILLC). SCILLC reserves the right to make changes without further notice to any products herein. SCILLC makes no warranty, representation or guarantee regarding the suitability of its products for any particular purpose, nor does SCILLC assume any liability arising out of the application or use of any product or circuit, and specifically disclaims any and all liability, including without limitation special, consequential or incidental damages. "Typical" parameters which may be provided in SCILLC data sheets and/or specifications can and do vary in different applications and actual performance may vary over time. All operating parameters, including "Typicals" must be validated for each customer application by customer's technical experts. SCILLC does not convey any license under its patent rights nor the rights of others. SCILLC products are not designed, intended, or authorized for use as components in systems intended for surgical implant into the body, or other applications intended to support or sustain life, or for any other application in which the failure of the SCILLC product could create a situation where personal injury or death may occur. Should Buyer purchase or use SCILLC products for any such unintended or unauthorized application, Buyer shall indemnify and hold SCILLC and its officers, employees, subsidiaries, affiliates, and distributors harmless against all claims, costs, damages, and expenses, and reasonable attorney fees arising out of, directly or indirectly, any claim of personal injury or death associated with such unintended or unauthorized use, even if such claim alleges that SCILLC was negligent regarding the design or manufacture of the part. SCILLC is an Equal Opportunity/Affirmative Action Employer. This literature is subject to all applicable copyright laws and is not for resale in any manner.

PUBLICATION ORDERING INFORMATION

LITERATURE FULFILLMENT:
Literature Distribution Center for ON Semiconductor
P.O. Box 5163, Denver, Colorado 80217 USA
Phone: 303-675-2175 or 800-344-3860 Toll Free USA/Canada
Fax: 303-675-2176 or 800-344-3867 Toll Free USA/Canada
Email: orderlit@onsemi.com

N. American Technical Support: 800-282-9855 Toll Free USA/Canada
Europe, Middle East and Africa Technical Support:
Phone: 421 33 790 2910
Japan Customer Focus Center
Phone: 81-3-5773-3850

ON Semiconductor Website: www.onsemi.com
Order Literature: <http://www.onsemi.com/orderlit>
For additional information, please contact your local Sales Representative