



Chipsmall Limited consists of a professional team with an average of over 10 year of expertise in the distribution of electronic components. Based in Hongkong, we have already established firm and mutual-benefit business relationships with customers from,Europe,America and south Asia,supplying obsolete and hard-to-find components to meet their specific needs.

With the principle of “Quality Parts,Customers Priority,Honest Operation,and Considerate Service”,our business mainly focus on the distribution of electronic components. Line cards we deal with include Microchip,ALPS,ROHM,Xilinx,Pulse,ON,Everlight and Freescale. Main products comprise IC,Modules,Potentiometer,IC Socket,Relay,Connector.Our parts cover such applications as commercial,industrial, and automotives areas.

We are looking forward to setting up business relationship with you and hope to provide you with the best service and solution. Let us make a better world for our industry!



Contact us

Tel: +86-755-8981 8866 Fax: +86-755-8427 6832

Email & Skype: info@chipsmall.com Web: www.chipsmall.com

Address: A1208, Overseas Decoration Building, #122 Zhenhua RD., Futian, Shenzhen, China



NCN49599

Product Preview

Power Line Communication Modem

The NCN49599 is a powerful spread frequency shift keying (S-FSK) communication system-on-chip (SoC) designed for communication in hostile environments.

It combines a low power ARM Cortex M0 processor with a high precision analogue front end and a robust line driver. Based on 4800 baud S-FSK dual-channel technology, it offers an ideal compromise between speed and robustness.

It is functionally compatible with the NCN49597 and NCS5651 chip set, offering frequencies to cover all CENELEC bands for use in applications such as e-metering, home automation and street lighting. The NCN49599 benefits for more than 10 years of field experience in e-metering and delivers innovative features such as a smart synchronization and in-band statistics.

Fully reprogrammable, the modem firmware can be updated in the field. Multiple royalty-free firmware options are available from ON Semiconductor; refer to the separate datasheets for details. The configurable GPIOs allow connecting peripherals such as LCDs or metering ICs.

Features

- Power Line Communication (PLC) Modem for 50 Hz, 60 Hz and DC Mains
- Embedded Highly Linear 2-stage Power Amplifier with Current Limitation, Thermal Protection, Enable/Shutdown Control, Rail-to-rail Drop of only ± 1 V at $I_{out} = 1.5$ A
- Embedded ARM Cortex M0 Processor
- 8 General-purpose IOs Controllable by Software
- Embedded 32 kB RAM; Embedded 2 kB ROM
- Hardware Compliant with CENELEC EN 50065-1 and EN 50065-7
- Half Duplex S-FSK Channel, Data Rate Selectable:
 - 300 – 600 – 1200 – 2400 – 4800 baud (@ 50 Hz);
 - 360 – 720 – 1440 – 2880 – 5760 baud (@ 60 Hz)
- Programmable Carrier Frequencies in CENELEC A, B, C and D Band
- UART for Interfacing with an Application Microcontroller
- Power Supply 3.3 V and 12 V
- Wide Junction Temperature Range: -40°C to $+125^{\circ}\text{C}$

Available Firmware Options

- ON PL110 – Mesh Networking with Collision Avoidance and Error Correction
- Complete Handling of Protocol Layers (physical, MAC, LLC)

This document contains information on a product under development. ON Semiconductor reserves the right to change or discontinue this product without notice.



ON Semiconductor®

www.onsemi.com

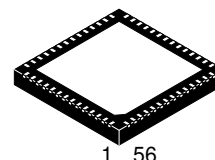

QFN56 8x8, 0.5P
CASE 485CN

MARKING DIAGRAMS

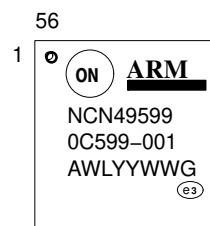

- A = Assembly Location
- WL = Wafer Lot Traceability
- YYWW = Date Code
- G = Green Designator

ORDERING INFORMATION

See detailed ordering and shipping information in the package dimensions section on page 33 of this data sheet.

Typical Applications

- AMR: Remote Automated Meter Reading
- Building Automation
- Solar Power Control and Monitoring
- Street Light Control and Monitoring
- Transmission of Alerts (fire, gas leak, water leak)

Application Example

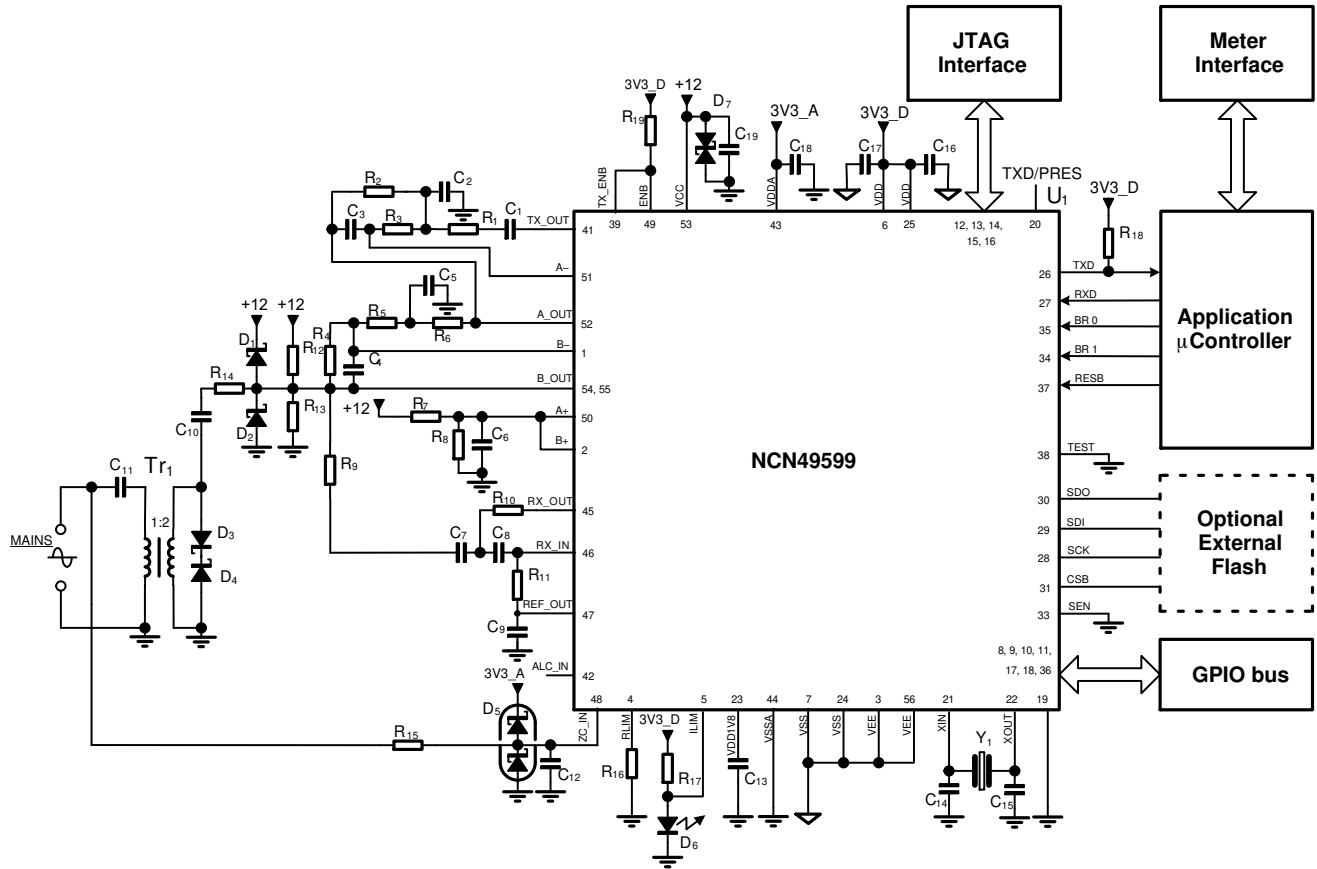

Figure 1. Typical Application for the NCN49599 S-FSK Modem

Figure 1 shows an S-FSK PLC modem built around the NCN49599. The design is a good starting point for a CENELEC. EN 50065-1-compliant system; for further information refer to the design manual in [1].

This design is not galvanically isolated; safety must be considered when interfacing to a microcontroller or a PC.

For synchronization the mains is coupled in via a 1 MΩ resistor; the Schottky diode pair D5 clamps the voltage within the input range of the zero crossing detector.

In the receive path a 2nd order high pass filter blocks the mains frequency. The corner point – defined by C7, C8, R10 and R11 – is designed at 10 kHz. In the transmit path a 3rd

order low pass filter built around the internal power operational amplifier suppresses the 2nd and 3rd harmonics to be in line with the CENELEC EN50065-1 specification. The filter components are tuned for a space and mark frequency of 63.3 and 74 kHz respectively, typically for e-metering in the CENELEC A-band. The output of the amplifier is coupled via a DC blocking capacitor C10 to a 2:1 transformer Tr1. The high voltage capacitor C11 couples the secondary of this transformer to the mains. High-energetic transients from the mains are clamped by the protection diode combination D3, D4, together with D1, D2.

Table 1. EXTERNAL COMPONENTS LIST AND DESCRIPTION

Component	Function and Remarks	Value	Tolerance	Unit
C ₁	TX_OUT signal coupling	470	±20%	nF
C ₂	Low pass transmit filter	470	±10%	pF
C ₃	Low pass transmit filter	68	±10%	pF
C ₄	Low pass transmit filter	3	±10%	pF
C ₅	Low pass transmit filter	2.7	±10%	nF
C ₆ , C ₁₆ , C ₁₇ , C ₁₈ , C ₁₉	Supply decoupling	100	-20 +80%	nF
C ₇ , C ₈	High pass receive filter	1	±10%	nF
C ₉ , C ₁₃	Internal 1.8 V supply decoupling; ceramic	10	-20 +80%	µF
C ₁₀	Transmission signal coupling; 1 A rms ripple @ 70 kHz	10	±20%	µF
C ₁₁	High Voltage coupling; 630 VDC	220	±20%	nF
C ₁₂	Zero Cross noise suppression	100	±20%	pF
C ₁₄ , C ₁₅	Crystal load capacitor	36	±20%	pF
R ₁	Low pass receive filter	3.3	±1%	kΩ
R ₂	Low pass receive filter	8.2	±1%	kΩ
R ₃ , R ₉ ,	Low pass transmit and high pass receive filter;	10	±1%	kΩ
R ₇ , R ₈	Amplifier bias	10	±1%	kΩ
R ₁₂ , R ₁₃	Receive mode input bias	10	±1%	kΩ
R ₁₈ , R ₁₉	Pull up	10	±1%	kΩ
R ₄	Low pass transmit filter	3	±1%	kΩ
R ₅	Low pass transmit filter	1	±1%	kΩ
R ₆	Low pass transmit filter	1.6	±1%	kΩ
R ₁₀	High pass receive filter	15	±1%	kΩ
R ₁₁	High pass receive filter	30	±1%	kΩ
R ₁₄	Line transients protection; 0.5 W	0.47	±1%	Ω
R ₁₅	Zero crossing coupling	1	±5%	MΩ
R ₁₆	Current protection	5	±1%	kΩ
R ₁₇	ILIM LED bias	3.3	±5%	kΩ
D ₁ , D ₂	High-current Schottky clamp diodes	MBRA340		
D ₃ , D ₄	Unidirectional TVS	P6SMB6.8AT3G		
D ₅	Dual low-current Schottky clamp diode	BAS70-04		
D ₆	ILIM LED indication (optional)	LED		
D ₇	TVS	1SMA12CA		
Y ₁	Crystall	48 MHz	50 ppm	
Tr ₁	2:1 signal transformer			
U ₁	PLC modem	NCN49599		

Table 2. ABSOLUTE MAXIMUM RATINGS

Rating	Symbol	Min	Max	Unit
POWER SUPPLY PINS VCC, VDD, VDD2, VDDA, VSS, VSSA				
Absolute maximum power amplifier supply	V_{CC_ABSM}	$V_{EE} - 0.3$	13.2	V
Absolute maximum digital amplifier power supply	V_{DD_ABSM}	$V_{SS} - 0.3$	3.9	V
Absolute maximum digital modem power supply	V_{DD_ABSM}	$V_{SS} - 0.3$	3.9	V
Absolute maximum analog power supply	V_{DDA_ABSM}	$V_{SSA} - 0.3$	3.9	V
Absolute maximum difference between digital and analog power supply	$V_{DD} - V_{DDA_ABSM}$	-0.1	0.1	V
Absolute maximum difference between digital and analog ground	$V_{SS} - V_{SSA_ABSM}$	-0.1	0.1	V
Absolute maximum difference between digital and power ground	$V_{SS} - V_{EE_ABSM}$	-0.5	0.5	V
CLOCK PINS XIN, XOUT				
Absolute maximum input for the clock input pin (Note 1)	V_{XIN_ABSM18}	$V_{SS} - 0.2$	$V_{DD18} + 0.2$	V
Absolute maximum voltage at the clock output pin (Note 1)	V_{XOUT_ABSM18}	$V_{SS} - 0.2$	$V_{DD18} + 0.2$	V
NON 5 V SAFE PINS: TX_OUT, ALC_IN, RX_IN, RX_OUT, REF_OUT, ZC_IN, TDO, SCK, SDO, SCB				
Absolute maximum input for normal digital inputs and analog inputs	V_{N5VSIN_ABSM}	$V_{SS} - 0.3$	$V_{DD} + 0.3$	V
Absolute maximum voltage at any output pin	$V_{N5VSOUT_ABSM}$	$V_{SS} - 0.3$	$V_{DD} + 0.3$	V
Maximum peak input current at the zerocrossing input pin	I_{mpZC_IN}	-20	20	mA
Maximum average input current at the zerocrossing input pin (1 ms)	I_{mavgZC_IN}	-2	2	mA
5 V SAFE PINS: TX_ENB, TXD, RXD, BR0, BR1, IO0..IO9, RESB, TDI, TCK, TMS, TRSTB, TEST, SDI				
Absolute maximum input for digital 5 V safe pins configured as input (Note 2)	V_{5VSIN_ABSM}	$V_{SS} - 0.3$	5.5	V
Absolute maximum voltage at 5V safe pin configured as output (Note 2)	V_{5VSOUT_ABSM}	$V_{SS} - 0.3$	$V_{DD} + 0.3$	V
AMPLIFIER PINS A+, A-, B+, B-, BOUT1, BOUT2, VWARN, XOUT				
Absolute maximum voltage at the analog amplifier pins	V_{AMPA_ABSM}	$V_{SS} - 0.3$	$V_{DD18} + 0.3$	V
Absolute maximum voltage at the amplifier control pins	V_{AMPC_ABSM}	$V_{SS} - 0.3$	$V_{CC} + 0.3$	V

Stresses exceeding those listed in the Maximum Ratings table may damage the device. If any of these limits are exceeded, device functionality should not be assumed, damage may occur and reliability may be affected.

1. The upper maximum voltage rating on the clock pins XIN and XOUT is specified with respect to the output voltage of the internal core voltage regulator. The tolerance of this voltage regulator must be taken into account. In case an external clock is used, care must be taken not to damage the XIN pin.
2. The direction (input or output) of configurable pins (IO0...IO9) depends on the firmware.

Normal Operating Conditions

Operating ranges define the limits for functional operation and parametric characteristics of the device as described in the Electrical Characteristics section and for the reliability specifications.

Total cumulative dwell time outside the normal power supply voltage range or the ambient temperature under bias, must be less than 0.1 percent of the useful life.

Table 3. OPERATING RANGES

Rating	Symbol	Min	Max	Unit
Power supply voltage range (VDDA and VDD pins)	V_{DD}, V_{DDA}	3.0	3.6	V
Power supply voltage range (VCC pin)	V_{CC}	6.0	12.0	V
Junction Temperature Range	T_J	-40	125	°C
Ambient Temperature Range	T_A	-40	85	°C

Functional operation above the stresses listed in the Recommended Operating Ranges is not implied. Extended exposure to stresses beyond the Recommended Operating Ranges limits may affect device reliability.

NCN49599

Pin Description – QFN Package

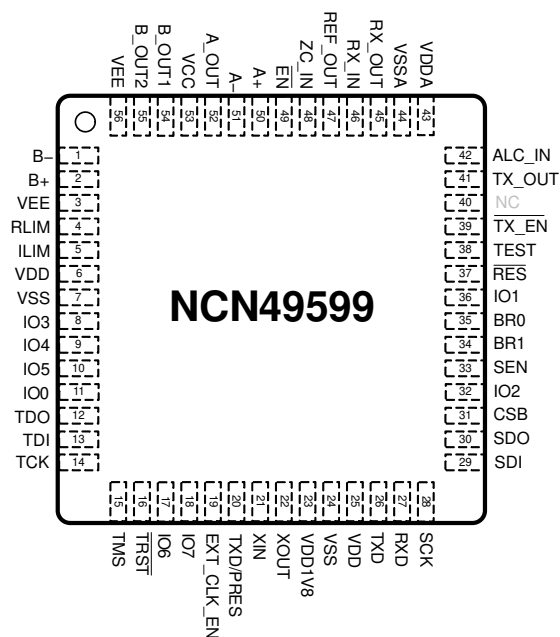

Figure 2. QFN Pin-out of NCN49599 (top view)

Table 4. NCN49599 QFN PIN FUNCTION DESCRIPTION

Pin Number	Pin Name	I/O	Type	Description
1	B-	In	A	Inverting input of operational amplifier B
2	B+	In	A	Non-inverting input of operational amplifier B
3, 56	VEE		P	Negative power supply amplifiers
4	RLIM	In	A	Amplifier B current limit set resistor pin
5	ILIM	In	A	Current limit flag
6, 25	VDD		P	3.3 V digital supply
7, 24	VSS	In	P	Digital ground
8..10, 17, 18	IO3...IO7	In/Out	D, 5VS, ST	General-purpose I/O's (Note 3)
11, 36	IO0, IO1	In/Out	D, 5VS, ST	General-purpose I/O's (Notes 3 and 4)
12	TDO	Out	D	JTAG test data output
13	TDI	In	D, 5VS, PD, ST	JTAG test data input (Note 7)
14	TCK	In	D, 5VS, PD	JTAG test clock (Note 7)
15	TMS	In	D, 5VS, PD	JTAG test mode select (Note 7)
16	TRSTB	In	D, 5VS, PD, ST	JTAG test reset (active low) (Note 8)
19	EXT_CLK_EN	In	D, 5VS, PD, ST	External clock enable input
20	TXD/PRES	Out	D, 5VS	Output of transmitted data (TXD) or PRE_SLOT signal (PRES)
21	XIN	In	A, 1.8V	Crystal oscillator input
22	XOUT	Out	A, 1.8V	Crystal oscillator output (output must be left floating when XIN is driven by external clock)

- The direction and function of the general-purpose I/O's is controlled by the firmware. Depending on the firmware behavior, a general-purpose IO (GPIO) used as an output may appear as an open-drain, push-pull or open-source pin. Refer to the firmware documentation for details.
- During boot (i.e., before firmware has been uploaded) this pin is an output and indicates the status of the boot loader. Once firmware has been loaded, the pin is available as a GPIO.
- During normal operation, this pin must be tied to ground (recommended) or left open.
- If the modem is not loading the firmware from an external SPI memory, it is recommended that this pin is tied to ground or Vdd.
- During normal operation, it is recommended that this pin is tied to ground.
- During normal operation, this pin must be tied to Vdd.
- If a general purpose IO is configured as an output, the pull-down resistor is disconnected.

Table 4. NCN49599 QFN PIN FUNCTION DESCRIPTION

Pin Number	Pin Name	I/O	Type	Description
23	VDD1V8		P	1.8 V regulator output. A decoupling capacitor of at least 1 μ F is required for stability
26	TXD	Out	D, 5VS, OD	UART transmit output
27	RXD	In	D, 5VS	UART receive input
28	SCK	Out	D, 5VS	SPI interface to external Flash: clock
29	SDI	In	D, 5VS, ST	SPI interface to external Flash: serial data input (Note 6)
30	SDO	Out	D, 5VS	SPI interface to external Flash: serial data output
31	CSB	In	D, 5VS	SPI interface to external Flash: chip select
32	IO2	In/Out	D, 5VS, ST	Must be kept low while firmware is loaded over the serial interface; available as a normal GPIO afterwards (Note 3)
33	SEN	In	D, 5VS, PD, ST	Boot mode selection (refer to Boot Loader section)
34	BR1	In	D, 5VS	UART baud rate selection
35	BR0	In	D, 5VS	UART baud rate selection
37	RESB	In	D, 5VS, ST	Reset (active low)
38	TEST	In	D, 5VS, ST, PD	Production hardware test enable (Note 5)
39	TX_ENB	Out	D, 5VS, OD	Transmit enable (active low)
40	NC	This pin is not connected and must be connected to ground (recommended) or left open		
41	TX_OUT	Out	A	Transmitter output
42	ALC_IN	In	A	Automatic level control input
43	VDDA		P	3.3 V analog supply
44	VSSA		P	Analog ground
45	RX_OUT	Out	A	Output of receiver operational amplifier
46	RX_IN	In	A	Non-inverting input of receiver operational amplifier
47	REF_OUT	Out	A	Internal voltage reference. A decoupling capacitor of at least 1 μ F is required for stability
48	ZC_IN	In	A	50/60 Hz input for mains zero crossing detection
49	ENB	In	D	Enable / shutdown power amplifier (active low)
50	A+	In	A	Non-inverting input of operational amplifier A
51	A-	In	A	Inverting input of operational amplifier A
52	A_OUT	Out	A	Output of operational amplifier A
53	VCC		P	Positive supply for power amplifiers A and B
54	B_OUT1	Out	A	Output of operational amplifier B
55	B_OUT2	Out	A	Output of operational amplifier B

3. The direction and function of the general-purpose I/O's is controlled by the firmware. Depending on the firmware behavior, a general-purpose IO (GPIO) used as an output may appear as an open-drain, push-pull or open-source pin. Refer to the firmware documentation for details.
4. During boot (i.e., before firmware has been uploaded) this pin is an output and indicates the status of the boot loader. Once firmware has been loaded, the pin is available as a GPIO.
5. During normal operation, this pin must be tied to ground (recommended) or left open.
6. If the modem is not loading the firmware from an external SPI memory, it is recommended that this pin is tied to ground or Vdd.
7. During normal operation, it is recommended that this pin is tied to ground.
8. During normal operation, this pin must be tied to Vdd.
9. If a general purpose IO is configured as an output, the pull-down resistor is disconnected.

P: Power pin
 A: Analogue pin
 D: Digital pin
 PD: Internal Pull Down resistor (Note 9)
 OD: Open Drain Output

5VS: 5 V safe; pin that supports the presence of 5 V if used as input or as open-drain output
 Out: Output signal
 In: Input signal

ELECTRICAL CHARACTERISTICS

All parameters are valid for $T_J = -40^{\circ}\text{C}$ to 125°C , $V_{DD} = 3.3\text{ V}$, $V_{CC} = 12\text{ V}$, $V_{EE} = 0\text{ V}$, $f_{CLK} = 48\text{ MHz} \pm 50\text{ ppm}$ unless otherwise specified.

Internal voltage regulator: pin VDD1V8

Table 5. POWER SUPPLY AND VOLTAGE REFERENCE

Parameter	Test Conditions	Symbol	Min	Typ	Max	Unit
Internal voltage regulator output		V_{DD18}	1.62	1.80	1.98	V
V_{DD} and V_{DDA} current consumption	During reception (Note 10)	I_{RX}		40	60	mA
	During transmission (Note 10)	I_{TX}		40	60	mA
	RESB = 0	I_{RESET}			4	mA
V_{CC} quiescent current consumption	ENB = 0; no load	I_{Q_EN}		20	40	mA
	ENB = 1	I_{Q_HiZ}		120	150	μA

10. With typical firmware. The exact value depends on the firmware variant loaded and the firmware configuration.

Oscillator: pin XIN, XOUT

In production the actual oscillation of the oscillator and duty cycle will not be tested. The production test will be based on the static parameters and the inversion from XIN to XOUT in order to guarantee the functionality of the oscillator.

Table 6. OSCILLATOR

Parameter	Test Conditions	Symbol	Min	Typ	Max	Unit
Duty cycle with quartz connected			35		65	%
Start-up time		$T_{startup}$			15	ms
Load capacitance external crystal		C_L			18	pF
Series resistance external crystal		R_S	1	6	60	Ω
Maximum Capacitive load on XOUT	XIN used as clock input	C_{LXOUT}			15	pF
Low input threshold voltage	XIN used as clock input	V_{ILXOUT}	$0.3 V_{DD18}$			V
High input threshold voltage	XIN used as clock input	V_{IHXOUT}			$0.7 V_{DD18}$	V
Low output voltage	XIN used as clock input, XOUT = 2 mA	V_{OLXOUT}			0.3	V
High input voltage	XIN used as clock input	V_{OHXOUT}			$V_{DD18} - 0.3$	V
Rise and fall time on XIN	XIN used as clock input	t_{rXIN_EXT}			1.5	ns

Zero Crossing detector and 50/60 Hz PLL: pin ZC_IN

Table 7. ZERO CROSSING DETECTOR AND 50/60 HZ PLL

Parameter	Test Conditions	Symbol	Min	Typ	Max	Unit
Mains voltage input range	With protection resistor at ZC_IN (Note 11)	V_{MAINS}	90		550	V_{PK}
Rising threshold level		V_{IRZC_IN}			1.9	V
Falling threshold level		V_{IFZC_IN}	0.85			V
Hysteresis		V_{HYZC_IN}	0.4			V
Lock range (Note 12)	R_CONF[0] = 0 (50 Hz)	Flock _{50Hz}	45		55	Hz
	R_CONF[0] = 1 (60 Hz)	Flock _{60Hz}	54		66	Hz
Lock time (Note 12)	R_CONF[0] = 0 (50 Hz)	Tlock _{50Hz}			15	s
	R_CONF[0] = 1 (60 Hz)	Tlock _{60Hz}			20	s

11. This parameter is not tested in production.

12. These parameters will not be measured in production as the performance is determined by a digital circuit. Correct operation of this circuit will be guaranteed by the digital test patterns.

Table 7. ZERO CROSSING DETECTOR AND 50/60 HZ PLL

Parameter	Test Conditions	Symbol	Min	Typ	Max	Unit
Frequency variation without going out of lock (Note 12)	R_CONF[0] = 0 (50 Hz)	DF _{60Hz}			0.1	Hz/s
Frequency variation without going out of lock (Note 12)	R_CONF[0] = 1 (60 Hz)	DF _{50Hz}			0.1	Hz/s
Jitter of CHIP_CLK (Note 12)		Jitter _{CHIP_CLK}			25	μs

11. This parameter is not tested in production.

12. These parameters will not be measured in production as the performance is determined by a digital circuit. Correct operation of this circuit will be guaranteed by the digital test patterns.

Transmitter External Parameters: pin TX_OUT, ALC_IN, TX_ENB

Table 8. TRANSMITTER EXTERNAL PARAMETERS

Parameter	Test Conditions	Symbol	Min	Typ	Max	Unit
AC output level	f _{TX_OUT} = 23 – 75 kHz (Note 13) f _{TX_OUT} = 148.5 kHz (Note 13)	V _{TX_OUT}	0.85 0.76		1.15 1.22	V _{PK} V _{PK}
DC output level		V _{TX_OUT}		1.65		V
Second order harmonic distortion	f _{TX_OUT} = 148.5 kHz (Note 13)	HD2			-55	dB
Third order harmonic distortion	f _{TX_OUT} = 148.5 kHz (Note 13)	HD3			-57	dB
Transmitted carrier frequency resolution		Rf _{TX_OUT}	11.44		11.44	Hz
Transmitted carrier frequency accuracy	(Note 14)	Df _{TX_OUT}			30	Hz
Capacitive output load at pin TX_OUT	(Note 14)	CL _{TX_OUT}			20	pF
Resistive output load at pin TX_OUT		RL _{TX_OUT}	5		5	kΩ
Turn off delay of TX_ENB output		Td _{TX_ENB}	0.25		0.5	ms
Automatic level control attenuation step		ALC _{step}	2.9		3.1	dB
Maximum attenuation		ALC _{range}	20.3		21.7	dB
Low threshold level on ALC_IN	With DC bias equal to V _{REF_OUT}	V _{TL} _{ALC_IN}	0.34		0.46	V _{PK}
High threshold level on ALC_IN	With DC bias equal to V _{REF_OUT}	V _{TH} _{ALC_IN}	0.54		0.72	V _{PK}
Input impedance of ALC_IN pin		R _{ALC_IN}	111		189	kΩ
Power supply rejection ratio of the transmitter section	f = 50 Hz (Note 15) f = 10 kHz (Note 15)	PSRR _{TX_OUT}	32 10			dB
Transmit cascade gain (Note 16)	f = 10 kHz f = 148.5 kHz f = 195 kHz f = 245 kHz f = 500 kHz f = 1 MHz f = 2 MHz	V _{TX_PF_10kHz} V _{TX_LPF_148kHz5} V _{TX_LPF_195kHz} V _{TX_LPF_245kHz} V _{TX_LPF_500kHz} V _{TX_LPF_1000kHz} V _{TX_LPF_2000kHz}	-0.5 -1.3 -4.5		0.5 -1.5 -3 -18	dB
				-36 -50		

13. With the level control register set for maximal output amplitude. Tested with low pass filter tuned for CENELEC D-band.

14. This parameter will not be tested in production.

15. A sinusoidal signal of 100 mVpp is injected between VDDA and VSSA while the digital AD converter generates an idle pattern. The signal level at TX_OUT is measured to determine the parameter.

16. The cascade of the digital-to-analog converter (DAC), low-pass filter (LPF), and transmission amplifier is production tested and must have a frequency characteristic between the limits listed. The level is specified relative to the level at DC; the absolute output level will depend on the operating condition.

This test is done with the low-pass filter (LPF) tuned to include the CENELEC D-band. In production the measurement will be done for relative to DC with a signal amplitude of 100 mV.

Power amplifier parameters: Pin A+, A-, A_OUT, B+, B-, BOUT1&2, VSS, VEE, ENB, ILIM, RLIM

Table 9. POWER AMPLIFIER GENERAL PARAMETERS

Parameter	Test Conditions	Symbol	Min	Typ	Max	Unit
Output shutdown time	ENB 0 → 1			60		ns
Output enable time	ENB 1 → 0			5	10	μs
Junction temperature shutdown threshold	(Note 17)		+150	+160		°C
Junction temperature shutdown recovery threshold	(Note 17)			+135		°C
ENB input level high		V _{IH,EN}	2			V
ENB input level low		V _{IL,EN}			0.8	V
ENB input current	V _{ENB} = 3.3 V			10		μA
	V _{ENB} = 0 V			0.1		μA
ILIM flag output high level		V _{IH,EN}			2	V
ILIM flag output low level		V _{IL,EN}	0.8			V

17. Characterization data only. Not tested in production.

Table 10. POWER AMPLIFIER EXTERNAL PARAMETERS OP AMP A

Parameter	Test Conditions	Symbol	Min	Typ	Max	Unit
Input offset voltage		V _{OS,A}		±3	±10	mV
Offset vs power supply	V _{CC} = +6 V, V _{EE} = -6 V	PSRR _A		25	150	μV/V
Input bias current	(Note 18)	I _{B,A}			1	nA
Input voltage noise density	f = 1 kHz, V _{IN} = GND, BW = 131 kHz (Note 18)	e _{n,A}		250		nV/√Hz
Common-mode voltage range		V _{CM,A}	V _{EE} - 0.1		V _{CC} - 3	V
Common-mode rejection ratio	V _{EE} - 0.1 ≤ V _{CM} ≤ V _{CC} - 3	CMRR _A	70	85		dB
Differential input impedance		Z _{IDM,A}		0.2 1.5		GΩ pF
Common-mode input impedance		Z _{ICM,A}		0.2 3		GΩ pF
Open-loop gain	R _L = 500 Ω (Note 18)	A _{OL,A}	80	100		dB
Gain bandwidth product		GBW _A		80		MHz
Full power bandwidth	G = +5, V _{out} = 11 V _{PP} (Note 18)		0.2	1.5		MHz
Slew rate		SR _A		60		V/μs
Total harmonic distortion and noise	G = +1, R _L = 500 Ω, V _O = 8 V _{PP} , f = 1 kHz, C _{IN} = 220 μF, C _{OUT} = 330 μF	THD+N _A		0.015		%
	G = +1, R _L = 50 Ω, V _O = 8 V _{PP} , f = 100 kHz, C _{IN} = 220 μF, C _{OUT} = 330 μF	THD+N _A		0.023		%
Voltage output swing from rail	V _{CC} = +12 V, V _{EE} = 0 V					
From positive rail	IL = -12 mA	V _{OH,A}		0.3	1	V
From negative rail	IL = +12 mA	V _{OL,A}		0.3	1	V
Short-circuit current		I _{SC,A}		280		mA
Output impedance	Closed Loop G = +4, f = 100 kHz	Z _{O,A}		0.25		Ω
Capacitive load drive		C _{LOAD,A}		100		pF

18. Characterization data only. Not tested in production.

Table 11. POWER AMPLIFIER EXTERNAL PARAMETERS OP AMP B

Parameter	Test Conditions	Symbol	Min	Typ	Max	Unit
Input offset voltage		$V_{OS,B}$		± 3	± 10	mV
Offset vs power supply		$PSRR_B$		25	150	$\mu V/V$
Input bias current	(Note 19)	$I_{B,B}$			1	nA
Input voltage noise density	$f = 1 \text{ kHz}$, $V_{IN} = \text{GND}$, $BW = 131 \text{ kHz}$	$e_{n,B}$		125		nV/ $\sqrt{\text{Hz}}$
Common-mode voltage range		$V_{CM,B}$	$V_{EE} - 0.1$		$V_{CC} - 3$	V
Common-mode rejection ratio	$V_{EE} - 0.1 \leq V_{CM} \leq V_{CC} - 3$	$CMRR_B$	70	85		dB
Differential input impedance		$Z_{IDM,B}$		0.2 11		$G\Omega$ pF
Common-mode input impedance		$Z_{ICM,B}$		0.2 22		$G\Omega$ pF
Open-loop gain	$R_L = 5 \Omega$ (Note 19)	$A_{OL,B}$	80	100		dB
Gain bandwidth product		GBW_B		60		MHz
Full power bandwidth	$G = +2$, $V_{out} = 11 V_{PP}$ (Note 19)		200	400		kHz
Slew rate		SR_B		70		V/ μs
Total harmonic distortion and noise	$G = +1$, $R_L = 50 \Omega$, $V_O = 8 V_{PP}$, $f = 1 \text{ kHz}$	THD+N _B		0.015		%
	$G = +1$, $R_L = 50 \Omega$, $V_O = 8 V_{PP}$, $f = 100 \text{ kHz}$	THD+N _B		0.067		%
Voltage output swing from positive rail	$I_{OUT} = -1.5 \text{ A}$ @ $T_J = 25^\circ\text{C}$	$V_{OH,B}$		0.7	1	V
	$I_{OUT} = -1.0 \text{ A}$ @ $T_J = 125^\circ\text{C}$	$V_{OH,B}$		0.7	1	V
Voltage output swing from negative rail	$I_{OUT} = +1.5 \text{ A}$ @ $T_J = 25^\circ\text{C}$	$V_{OH,B}$		0.4	1	V
	$I_{OUT} = +1.0 \text{ A}$ @ $T_J = 125^\circ\text{C}$	$V_{OH,B}$		0.4	1	V
Short-circuit current	$R_{LIM} = 5 \text{ k}\Omega$	$I_{SC,B}$	1.2			A
Output impedance	Closed Loop $G = +1$, $f = 100 \text{ kHz}$					
	ENB = 0 (enabled)	$Z_{O,B}$		0.065		Ω
	ENB = 1 (shutdown)	$Z_{O,B}$		12		M Ω
Capacitive load drive		$C_{LOAD,B}$		500		nF

19. Characterization data only. Not tested in production.

Receiver External Parameters: Pin RX_IN, RX_OUT, REF_OUT

Table 12. RECEIVER EXTERNAL PARAMETERS

Parameter	Test Conditions	Symbol	Min	Typ	Max	Unit
Input offset voltage	AGC gain = 42 dB	$V_{OFFS_RX_IN}$			5	mV
	AGC gain = 0 dB	$V_{OFFS_RX_IN}$			50	mV
Max. peak input voltage (corresponding to 62.5% of the ADC full scale)	AGC gain = 0 dB (Note 20)	$V_{MAX_RX_IN}$	0.85		1.15	V_{PK}
Input referred noise of the analog receiver path	AGC gain = 42 dB (Notes 20 and 21)	NF_{RX_IN}			150	nV/ $\sqrt{\text{Hz}}$
Input leakage current of receiver input		$I_{LE_RX_IN}$	-1		1	μA

20. Input at RX_IN, no other external components.

21. Characterization data only. Not tested in production.

22. A sinusoidal signal of 100 mVpp is injected between VDDA and VSSA. The signal level at the differential LPF_OUT and REF_OUT output is measured to determine the parameter. The AGC gain is fixed at 42 dB.

23. These parameters will be tested in production with an input signal of 95 kHz and 1 V_{PK} by reading out the digital samples at the output of the ADC. The AGC gain is switched to 0 dB.

24. The cascade of the receive low-pass filter (LPF), AGC and low noise amplifier is production tested and must have a frequency characteristic between the limits listed. The level is specified relative to the level at DC; the absolute output level will depend on the operating condition. This test is done with the low-pass filter (LPF) tuned to include the CENELEC D-band.

Table 12. RECEIVER EXTERNAL PARAMETERS

Parameter	Test Conditions	Symbol	Min	Typ	Max	Unit
Max. current delivered by REF_OUT		$I_{Max_REF_OUT}$	-300		300	μA
Power supply rejection ratio of the receiver input section	f = 50 Hz (Note 22)	PSRR _{LPF_OUT}	35			dB
	f = 10 kHz (Note 22)		10			dB
AGC gain step		AGC _{step}	5.3		6.7	dB
AGC range		AGC _{range}	39.9		44.1	dB
Analog ground reference output voltage	Load current $\pm 300 \mu A$	V _{REF_OUT}	1.52	1.65	1.78	V
Signal to noise ratio	Signal amplitude of 62.5% of the full scale of the ADC (Notes 20 and 23)	SN _{AD_OUT}	54			dB
Clipping level at the output of the gain stage (RX_OUT)		V _{CLIP_AGC_IN}	1.05		1.65	V _{PK}
Receive cascade gain (Note 24)	f = 10 kHz, A = 250 mVpk	V _{RX_LPF_10kHz}	-0.5	0	0.5	dB
	f = 148.5 kHz, A = 250 mVpk	V _{RX_LPF_148.5kHz}	-1.3		0.5	
	f = 195 kHz, A = 250 mVpk	V _{RX_LPF_195kHz}	-4.5		-1	
	f = 245 kHz, A = 250 mVpk	V _{RX_LPF_245kHz}			-3	
	f = 500 kHz, A = 250 mVpk	V _{RX_LPF_500kHz}			-18	
	f = 1 MHz	V _{RX_LPF_1000kHz}			-36	
	f = 2 MHz	V _{RX_LPF_2000kHz}			-50	

20. Input at RX_IN, no other external components.

21. Characterization data only. Not tested in production.

22. A sinusoidal signal of 100 mVpp is injected between VDDA and VSSA. The signal level at the differential LPF_OUT and REF_OUT output is measured to determine the parameter. The AGC gain is fixed at 42 dB.

23. These parameters will be tested in production with an input signal of 95 kHz and 1 V_{PK} by reading out the digital samples at the output of the ADC. The AGC gain is switched to 0 dB.

24. The cascade of the receive low-pass filter (LPF), AGC and low noise amplifier is production tested and must have a frequency characteristic between the limits listed. The level is specified relative to the level at DC; the absolute output level will depend on the operating condition. This test is done with the low-pass filter (LPF) tuned to include the CENELEC D-band.

Power-on-Reset (POR)

Table 13. POWER-ON-RESET

Parameter	Test Conditions	Symbol	Min	Typ	Max	Unit
POR threshold (Note 25)	V _{DD} and V _{DDA} rising	V _{PORH}			2.7	V
	V _{DD} and V _{DDA} falling	V _{PORL}	2.1			
Power supply rise time	0 to 3 V on both VDD and VDDA	T _{RPOR}	1			ms

25. The nominal voltage on the pins VDD and VDDA (the digital and analog power supply) must be equal; both supply rails must be switched together.

Digital Outputs: TDO, SCK, SDO, CSB, IO0..IO7

Table 14. DIGITAL OUTPUTS: TDO, SCK, SDO, CSB, IO0..IO7

Parameter	Test Conditions	Symbol	Min	Typ	Max	Unit
Low output voltage (Note 26)	I _{XOUT} = 4 mA	V _{OL}			0.4	V
High output voltage (Note 26)	I _{XOUT} = -4 mA	V _{OH}	0.85 V _{DD}			V

26. For IO0..IO7, this parameter only applies if the pin is configured as output pin by the firmware.

Digital Outputs with Open Drain: TX_ENB, TXD, DATA/PRES

Table 15. DIGITAL OUTPUTS WITH OPEN DRAIN: TX_ENB, TXD, DATA/PRES

Parameter	Test Conditions	Symbol	Min	Typ	Max	Unit
Low output voltage	$I_{XOUT} = 4 \text{ mA}$	V_{OL}			0.4	V

Digital Inputs: BR0, BR1

Table 16. DIGITAL INPUTS: BR0, BR1

Parameter	Test Conditions	Symbol	Min	Typ	Max	Unit
Low input level		V_{IL}			$0.2 V_{DD}$	V
High input level	0 to 3 V	V_{IH}	$0.8 V_{DD}$			V
Input leakage current		I_{LEAK}	-2		2	μA

Digital Inputs with Pull-down: TDI, TMS, TCK, TRSTB, TEST, SEN

Table 17. DIGITAL INPUTS WITH PULL-DOWN: TDI, TMS, TCK, TRSTB, TEST, SEN

Parameter	Test Conditions	Symbol	Min	Typ	Max	Unit
Low input level		V_{IL}			$0.2 V_{DD}$	V
High input level		V_{IH}	$0.8 V_{DD}$			V
Pull-down resistor	Measured at $V_{Pin} = V_{DD} / 2$	R_{PU}	35	100	170	$k\Omega$

Digital Schmitt Trigger Inputs: RXD, RESB, IO0..IO7, SDI

Table 18. DIGITAL SCHMITT TRIGGER INPUTS: RXD, RESB, IO0..IO7, SDI

Parameter	Test Conditions	Symbol	Min	Typ	Max	Unit
Rising threshold level (Note 27)		V_{T+}			$0.80 V_{DD}$	V
Falling threshold level (Note 27)		V_{T-}	$0.2 V_{DD}$			V
Input leakage current (Note 27)		I_{LEAK}	-2		2	μA

27. For IO0...IO7, this parameter only applies if the pin is configured as input pin by the firmware.

Boot Loader Timing

NOTE: The timing constraints shown in Table 19 governing the boot loader when uploading firmware over the serial interface are illustrated in Figure 3.

Parameters are valid for a baud rate of 115'200.

Table 19. BOOT LOADER TIMING

Parameter	Test Conditions	Symbol	Min	Typ	Max	Unit
IO2 setup time to falling edge of RESB	(Note 28)	t_{2s}	5			μs
Boot loader startup time	(Notes 28 and 29)	t_{stx}		135	200	ms
Inter-byte timeout sent to modem	(Note 28)	t_{IB}			20	ms
Boot loader acknowledgement after last byte correctly received	(Note 28)	t_{ACK}		3.6	12	ms
IO2 hold time after start of acknowledgement byte transmission	(Note 28)	t_{2h}	36			μs

28. These parameters will not be measured in production as the performance is determined by a digital circuit.

29. This parameter is specified with the oscillator stable. Refer to Tstartup for oscillator startup information.

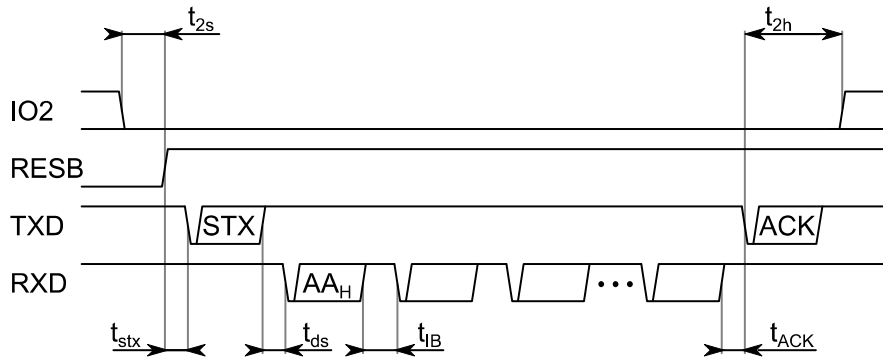

Figure 3. Timing constraints for uploading the firmware over the serial communication interface (SCI)

TYPICAL CHARACTERISTICS

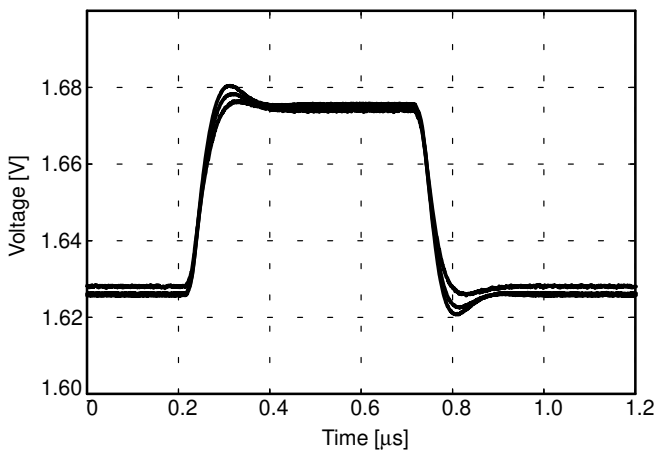

Figure 4. Receiver opamp – Small signal transient response for (top to centre) no load, 10 kΩ load, 3.6 kΩ load

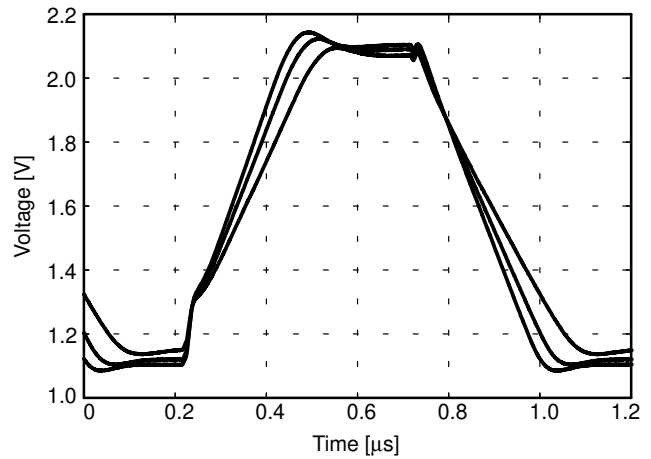

Figure 5. Receiver opamp – Large signal transient response for (top to centre) no load, 10 kΩ load, 3.6 kΩ load

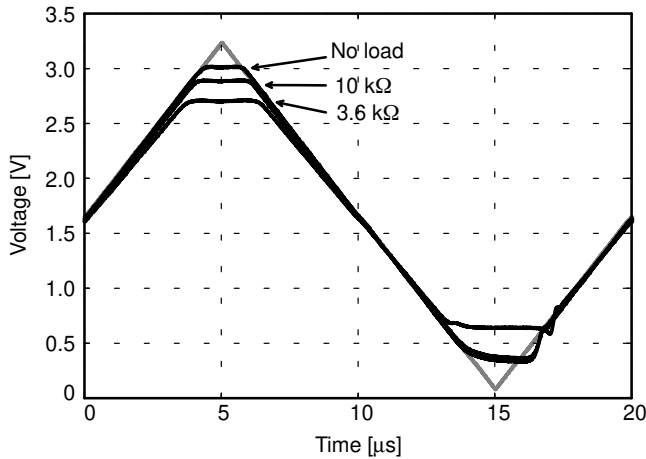

Figure 6. Receiver opamp – Output overdrive recovery behaviour. The input signal is shown in grey.

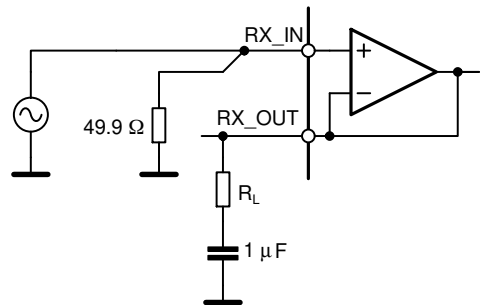

Figure 7. Test Circuit for Figures 4–6

TYPICAL CHARACTERISTICS

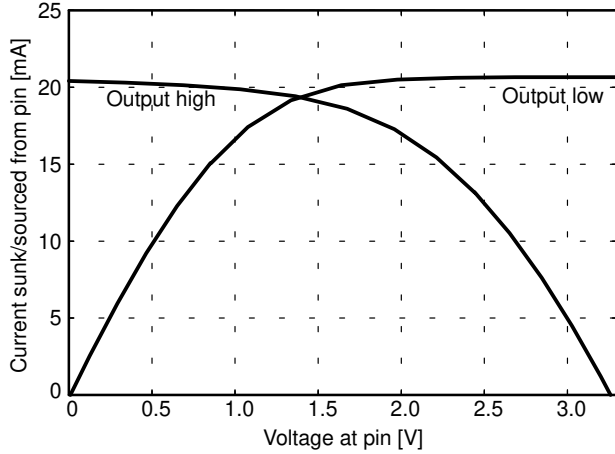

Figure 8. GPIO current sourcing and sinking capability

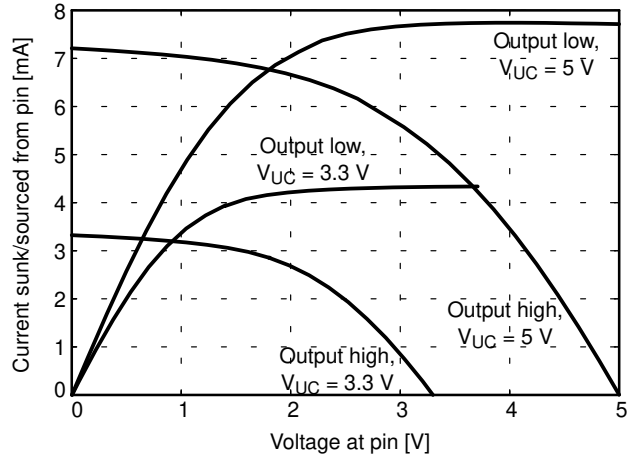

Figure 9. Overcurrent flag pin (ILIM) current sourcing and sinking capability

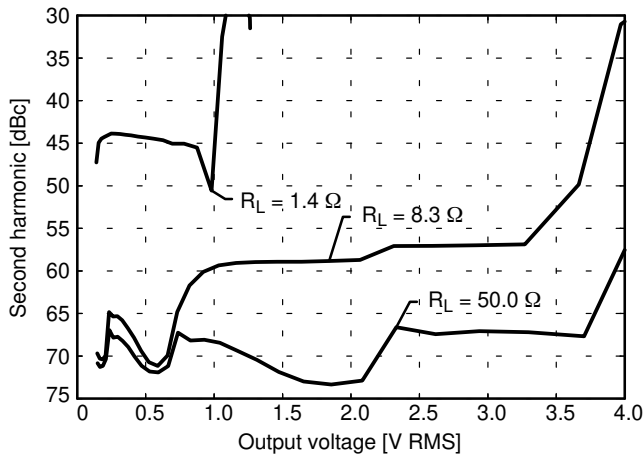

Figure 10. Second harmonic distortion of the output opamp vs. output amplitude, for $f = 100$ kHz and R_L (top to bottom) = 1.4Ω , 8.3Ω , 50Ω

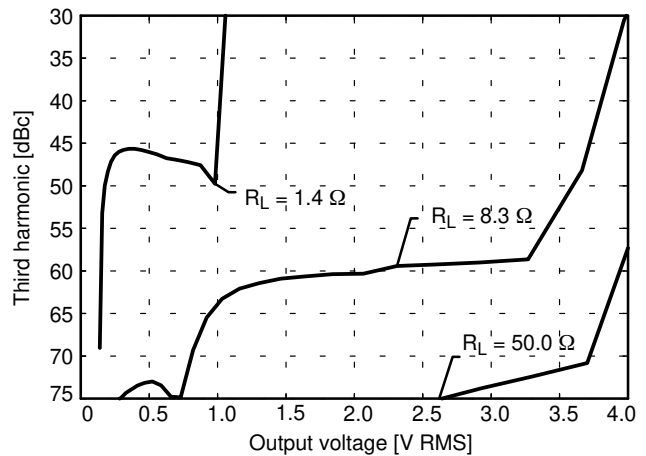

Figure 11. Third harmonic distortion of the output opamp vs. output amplitude, for $f = 100$ kHz and R_L (top to bottom) = 1.4Ω , 8.3Ω , 50Ω

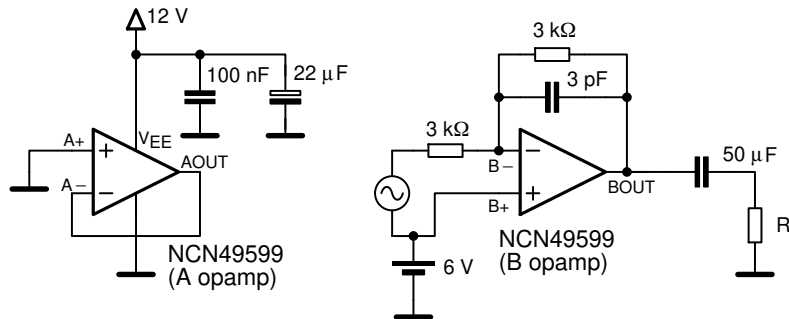

Figure 12. Test Circuit for Figures 10 and 11

GENERAL DESCRIPTION

The NCN49599 is a single-chip half duplex S-FSK modem with an integrated line driver. It is designed for hostile communication environments with very low signal-to-noise ratio (SNR) and high interference. It is particularly suited for power line carrier (PLC) data transmission on low-or medium-voltage power lines. Together with firmware, the device handles of the lower layers of communication protocols. Firmware solutions are provided by ON Semiconductor royalty-free for the ON PL110 protocol. It handles the physical, Media Access Control (MAC) and Logical Link Control (LLC) layers on-chip. For more information, refer to the dedicated software datasheet.

Because the lower layers are handled on-chip, the NCN49599 provides an innovative architectural split. The user benefits from a higher level abstraction. Compared to a low-level interface, the NCN49599 allows faster development of applications: the user just needs to send the raw data to the NCN49599 and no longer has to take care of the details of the transmission over the specific medium. The latter part easily represents half of the software development cost.

Figure 13 shows the building blocks of the NCN49599. Refer to the sections below for a detailed description.

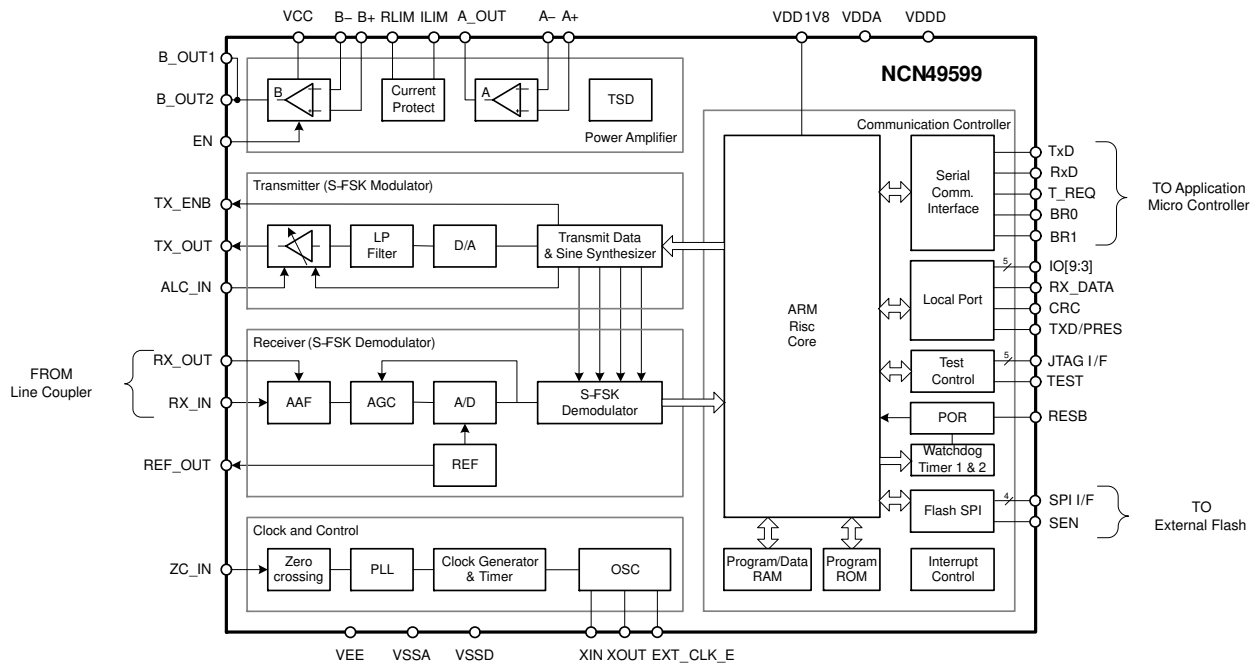

Figure 13. Block Diagram of the NCN49599 S-FSK Modem

NCN49599 complies with the CENELEC EN 50065-1 and EN 50065-7 standards. It operates from a single 3.3 V power supply and is interfaced to the power line by an external line driver and transformer. An internal PLL is locked to the mains frequency and is used to synchronize the data transmission at data rates of 300, 600, 1200, 2400 and 4800 baud for a 50 Hz mains frequency, or 360, 720, 1440, 2880 and 5760 baud for a 60 Hz mains frequency. In both cases this corresponds to 3, 6, 12 or 24 data bits per half cycle of the mains period.

S-FSK is a modulation and demodulation technique that combines some of the advantages of a classical spread spectrum system (e.g. immunity against narrow band interferers) with the advantages of the classical FSK system (low complexity). The transmitter assigns the space frequency f_s to “data 0” and the mark frequency f_m to “data 1”. In contrast to classical FSK, the modulation carriers f_s and f_m used in S-FSK are placed well apart. As interference

and signal attenuation seen at the carrier frequencies are now less correlated, this results in making their transmission quality independent from each other. Thus, more robust communication is possible in interference-prone environments. The frequency pairs supported by the NCN49599 are in the range of 9–150 kHz with a typical separation of 10 kHz.

The NCN49599 incorporates a line driver for transmission, enabling communication over low-impedance lines. The line driver is described in detail in the Power Amplifier section.

The conditioning and conversion of the signal is performed at the analogue front-end of the circuit. All further processing of the signal and the handling of the protocol is fully digital. The digital processing of the signal is partitioned between hardwired blocks and a microprocessor block. Where timing is most critical, the functions are implemented with dedicated hardware. For the

functions where the timing is less critical – typically the higher level functions – the circuit makes use of an integrated ARM microprocessor core. An internal random-access memory (RAM) stores the firmware and the working data.

After the modem has been reset, the user must upload the firmware into the modem memory. This may be done over the asynchronous serial interface (discussed below); alternatively, the modem can autonomously retrieve the firmware from an attached SPI memory. For details, refer to Boot Loader section.

The modem communicates to the application microcontroller over a Serial Communication Interface (SCI), a standard asynchronous serial link, which allows interfacing with any microcontroller with a free UART. The SCI works on two wires: TXD and RXD. The baud rate is programmed by setting two pins (BR0, BR1). The NCN49599 is functionally equivalent to the combination of an NCN49597 modem and an NCS5651 line driver. Thus, the same user software works equally well with the NCN49597 as with the NCN49599.

DETAILED HARDWARE DESCRIPTION

Clock and Control

The clock and control block (Figure 14) provides the modem with the clock and synchronization signals required for correct data transmission and reception. It is composed of the zero-crossing detector section, phase locked loop (PLL) section, oscillator section and clock generator section.

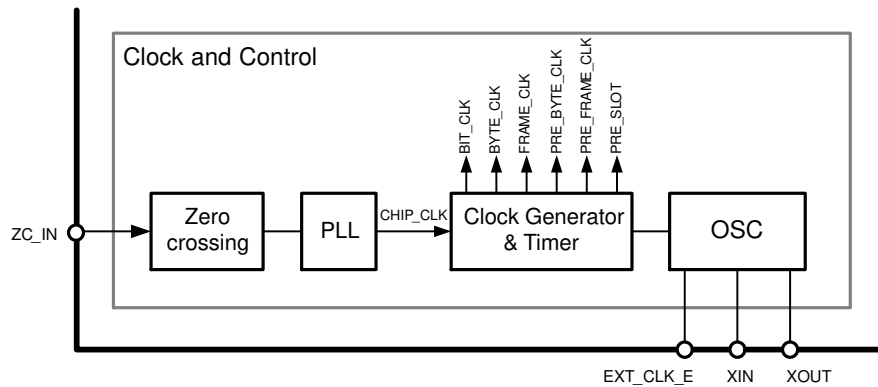

Figure 14. Clock and Control Block

Oscillator

The NCN49599 may be clocked from a crystal with the built-in oscillator or from an external clock. XIN is the input to the oscillator inverter gain stage; XOUT the output. XOUT cannot be used directly as a clock output as no additional loading is allowed on the pin due to the limited voltage swing. This applies both to operation with a crystal and an external oscillator.

If an external clock of 48 MHz is to be used, the pin EXT_CLK_E must be pulled to V_{DD} and the clock signal connected to XIN. Note that the high level on XIN must not exceed the voltage of the internal voltage regulator (V_{DD18}, or about 1.8 V). The output must be floating.

If a crystal is to be used, the pin EXT_CLK_E should be strapped to V_{SSA} and the circuit illustrated in Figure 15 should be employed.

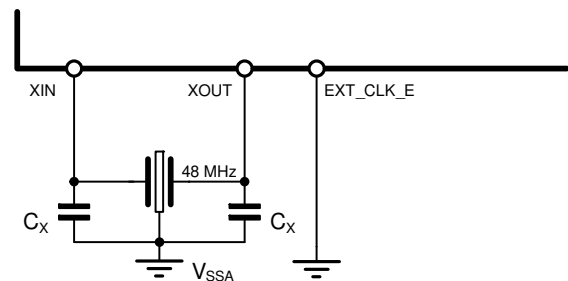

Figure 15. Clocking the NCN49599 with a Crystal

Correct operation is only possible with a parallel resonance crystal of 48 MHz. A crystal with a load capacitance C_L of 18 pF is recommended.

The load capacitance is the circuit capacitance appearing between the crystal terminals; it must be within the range specified by the crystal manufacturer for correct operation at the desired frequency. C_L is determined by the external capacitors C_X and stray capacitance (C_{STRAY}):

$$C_L = \frac{C_X}{2} + C_{STRAY}$$

Stray capacitance typically ranges from 2 to 5 pF. This results in a typical C_X value of 33pF.

The printed circuit board should be designed to minimise stray capacitance and capacitive coupling to other parts by keeping traces as short as possible. The quality of the ground plane below the oscillator components is critical.

To guarantee startup, the series loss resistance of the crystal must be smaller than 60 Ω .

The oscillator output f_{CLK} (48 MHz) is the base clock for the entire modem. The microcontroller clock, f_{ARM} , is taken directly from f_{CLK} . The clock for the transmitter, f_{TX_CLK} , is equal to $f_{CLK} / 4$ or 12 MHz; the master receiver clock, f_{RX_CLK} , equals $f_{CLK} / 8$ or 6 MHz. All the internal clock

signals of the transmitter and the receiver will be derived from f_{TX_CLK} resp. f_{RX_CLK} .

Zero Crossing Detector

Depending on the standard and the application, synchronization with the mains zero crossing may be required.

In order to recover this timing information, a zero cross detection of the mains is performed.

Recommended circuits for the detection of the mains zero crossing appear in the Application note “Mains synchronization for PLC modems”. In case the modem is not isolated from the mains a series resistor of 1 M Ω in combination with two external Schottky clamp diodes is recommended (Figure 16). This will limit the current flowing through the internal protection diodes.

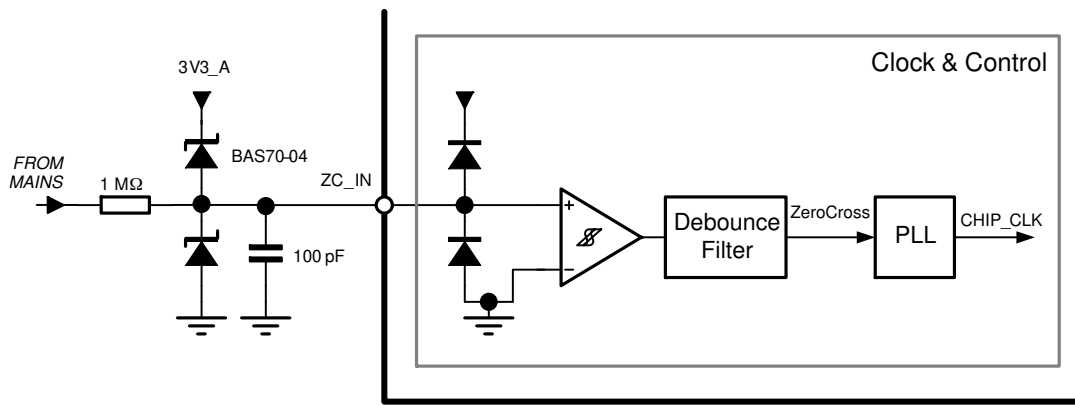

Figure 16. Zero Crossing Detector with Falling-edge De-bounce Filter

ZC_IN is the mains frequency sense pin. A comparator with Schmitt trigger ensures a signal with edges, even in the presence of noise. In addition, the falling edges of the detector output are de-bounced with a delay of 0.5–1 ms. Rising edges are not de-bounced.

Because the detector threshold is not 0 V but slightly positive, the rising edge of the output is delayed compared to the actual rising mains zero crossing (Figure 17).

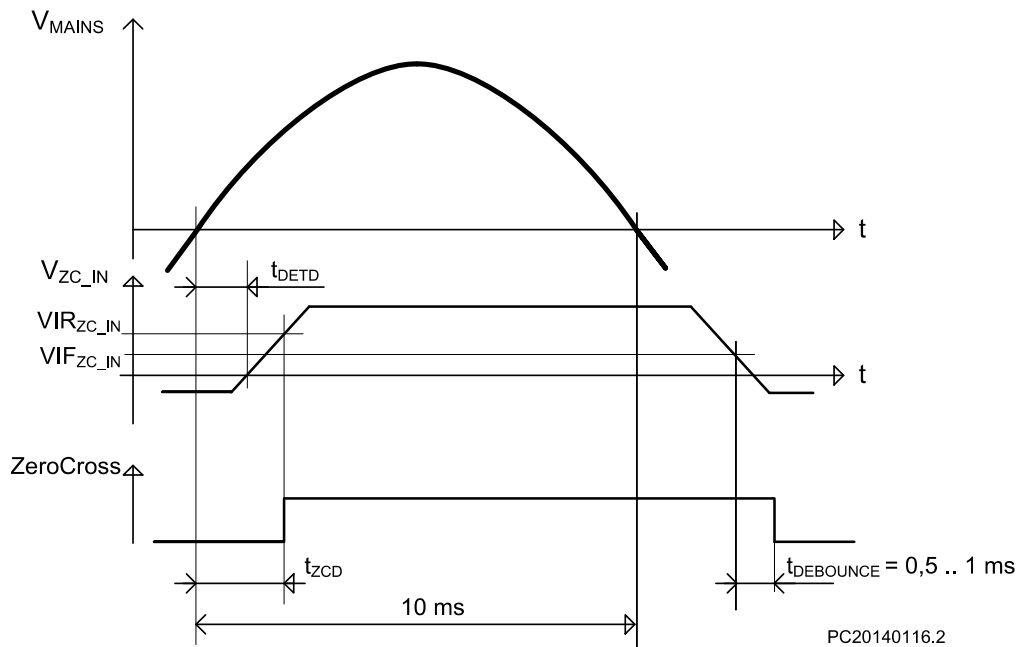

Figure 17. Zero Crossing Detector Signals and Timing (example for 50 Hz)

Phase Locked Loop (PLL)

A phase-locked loop (PLL) structure converts the signal at the ZC_IN comparator output to the chip clock (CHIP_CLK). This clock is used for modulation and demodulation and runs 8 times faster than the bit rate; as a result, the chip clock frequency depends on the mains frequency and the baud rate.

The filters of the PLL are dependent on the baud rate and the mains frequency. They must be correctly configured

using the register R_CONF. The bit R_CONF[0] specifies the mains frequency, with a cleared bit (0) corresponding to 50 Hz; a set bit (1) to 60 Hz. The bits R_CONF[2:1] control the number of data bits per mains period. The values 00b, 01b, 10b and 11b correspond to 6, 12, 24 and 48 bits per mains period of 20 ms (50 Hz) or 16.7 ms (60 Hz).

Together this results in the baud rates and chip clock frequencies shown in Table 20.

Table 20. CHIP_CLK IN FUNCTION OF SELECTED BAUD RATE AND MAINS FREQUENCY

R_CONF[0]	Mains Frequency	R_CONF[2:1]	Baudrate	CHIP_CLK
0	50 Hz	00b	300 bps	2400 Hz
		01b	600 bps	4800 Hz
		10b	1200 bps	9600 Hz
		11b	2400 bps	19200 Hz
1	60 Hz	00b	360 bps	2880 Hz
		01b	720 bps	5760 Hz
		10b	1440 bps	11520 Hz
		11b	2880 bps	23040 Hz

The PLL significantly reduces the clock jitter. This makes the modem less sensitive to timing variations; as a result, a cheaper zero crossing detector circuit may be used.

The PLL input is only sensitive to rising edges. If no zero crossings are detected, the PLL freezes its internal timers in order to maintain the CHIP_CLK timing.

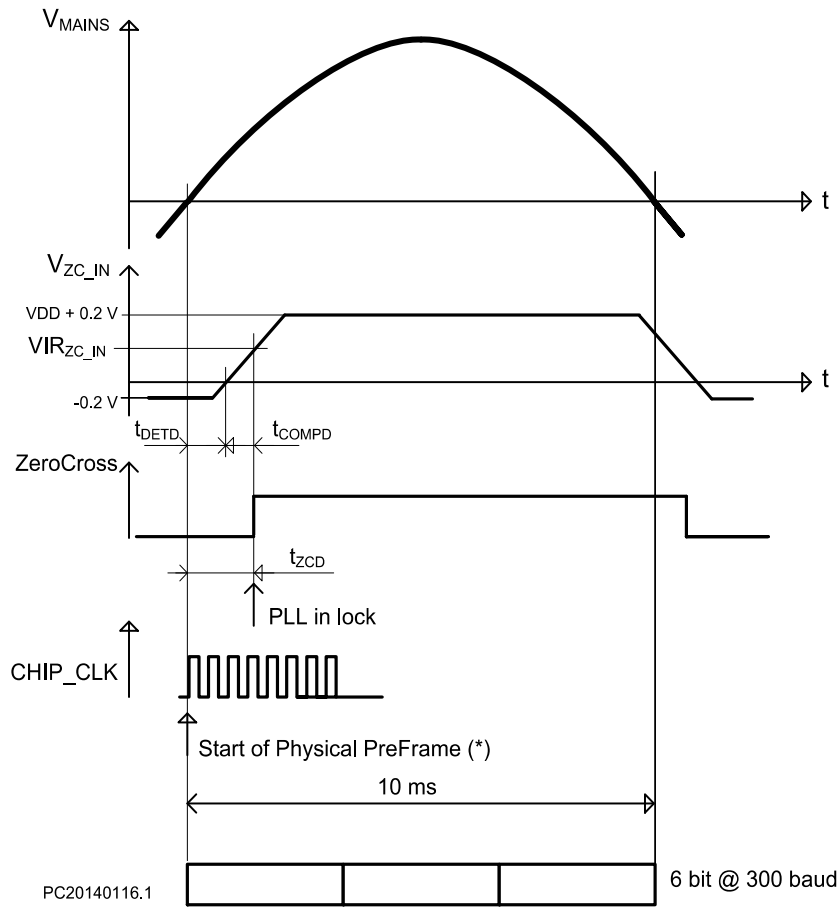

Figure 18. Using the ZC_ADJUST register to compensate for zero crossing delay (example for 50 Hz)

The PLL ensures the generated chip clock is in phase with the rising edge of comparator output. However, these edges are not precisely in phase with the mains.

Inevitably, the external zero crossing detector circuit suffers from a delay t_{DETD} (e.g. caused by an optocoupler). In addition, the comparator threshold is not zero ($V_{IR_{ZC_IN}} = 1.9\text{ V}$); this results in a further delay, t_{COMP0} between the rising edge of the signal on pin ZC_IN and the rising edge on the comparator output (as noted before, the PLL takes only the rising edge into account).

The combination of these delays would cause the modem to emit and receive data frames too late.

Therefore, the PLL allows tuning the phase difference between its input and the chip clock. The CHIP_CLK may be brought forward by setting the register R_ZC_ADJUST. The adjustment period or granularity is $13\ \mu\text{s}$, with a maximum adjustment of $255 \cdot 13\ \mu\text{s} = 3,3\text{ ms}$, corresponding with a sixth of the 50 Hz mains sine period.

This is illustrated in Figure 9. The “physical frame” (i.e., the modulated signal appearing on the mains) starts earlier with $R_ZC_ADJUST[7:0] \cdot 13\ \mu\text{s}$ to compensate for the zero cross delay.

The delay corresponding with the value of R_ZC_ADJUST is also listed in Table 21.

Table 21. ZERO CROSSING DELAY COMPENSATION

R_ZC_ADJUST[7:0]	Compensation
0000 0000	0 μs (reset value)
0000 0001	13 μs
0000 0010	26 μs
0000 0011	39 μs
...	...
1111 1111	3315 μs

Clock Generator and Timer

The timing generator (Figure 14, centre) is responsible for all synchronization signals and interrupts related to S-FSK communication.

The timing is derived from the chip clock (CHIP_CLK, generated by the PLL) and the main oscillator clock f_{CLK} . The timing has a fixed repetition rate, corresponding to the length of a physical subframe (see reference [1]).

When the NCN49599 switches between receive and transmit mode, the chip clock counter value is maintained. As a result, the same timing is maintained for reception and transmission. Seven timing signals are defined:

- **CHIP_CLK** is the output of the PLL and the input of the timing generator. It runs 8 times faster than the bit rate on the physical interface.
- **BIT_CLK** is only active at chip clock counter values that are multiples of 8 (0, 8, ..., 2872). It indicates the start of the transmission of a new bit.
- **BYTE_CLK** is only active at chip clock counter values that are multiples of 64 (0, 64, ..., 2816). It indicates the start of the transmission of a new byte.
- **FRAME_CLK** is only active at counter value 0; it indicates the transmission or reception of a new frame.
- **PRE_BYTE_CLK** follows the same pattern as **BYTE_CLK**, but precedes it by 8 chip clocks. It can be used as an interrupt for the internal microcontroller and

- indicates that a new byte for transmission must be generated.
- **PRE_FRAME_CLK** follows the same pattern at **FRAME_CLK**, but precedes it by 8 chip clocks. It can be used as an interrupt for the internal microcontroller and indicates that a new frame will start at the next **FRAME_CLK**.
- **PRE_SLOT** is active between the rising edge of **PRE_FRAME_CLK** and the rising edge of **FRAME_CLK**. This signal can be provided at the digital output pin **DATA/PRES** when **R_CONF[7] = 0**. Thus, the external host controller may synchronize its software with the internal **FRAME_CLK** of the NCN49599. Refer to the SCI section and Table 26 for details.

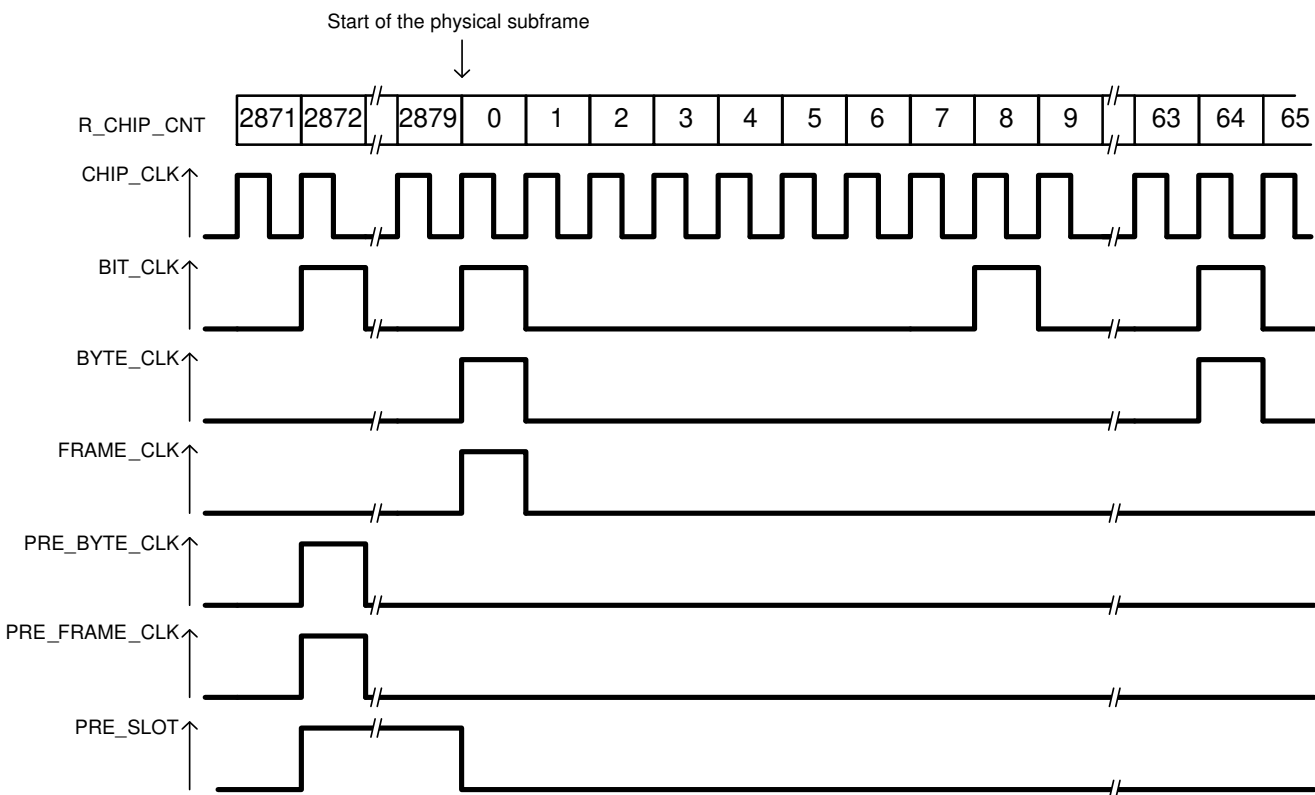

Figure 19. Timing Signals

Transmitter Path Description (S-FSK Modulator)

The NCN49599 transmitter block (Figure 21) generates the signal to be sent on the transmission channel. Most commonly, the output is connected to a power amplifier which injects the output signal on the mains through a line-coupler.

As the NCN49599 is a half-duplex modem, this block is not active when the modem is receiving.

The transmitter block is controlled by the microcontroller core, which provided the bit sequence to be transmitted. Direct digital synthesis (DDS) is employed to synthesize the modulated signal (the Sine Wave Generator section); after a conditioning step, this signal is converted to an analogue voltage (the DA Converter section). Finally, an amplifier with variable gain buffers the signal (the Amplifier with ALC section) and outputs it on pin TX_OUT.

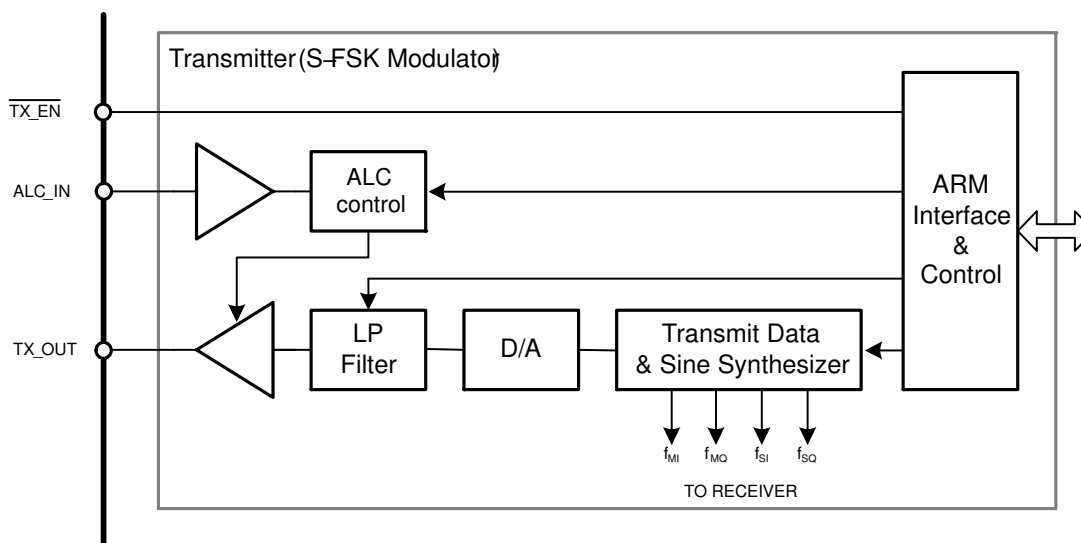

Figure 20. Transmitter Block Diagram

Microcontroller Interface & Control

The interface with the internal ARM microcontroller consists of an 8-bit data register R_TX_DATA, 2 control registers R_TX_CTRL and R_ALC_CTRL, a flag TX_RXB defining the operating mode (a high level corresponding to transmit mode; low to receive) and the frequency control registers. All these registers are memory mapped; most can be accessed through the firmware: refer to the specific firmware documentation for details.

Sine Wave Generator

The direct digital synthesizer (DDS) generates a sinusoidal signal alternating between the space frequency (f_S , data 0) and the mark frequency (f_M , data 1) as required to modulate the desired bit pattern. Two 16-bit wide frequency step registers, R_FM and R_FS, control the steps used by the DDS and thus the frequencies.

The space and mark frequency can be calculated using

$$f_S = R_{FS}[15:0]_{dec} \cdot f_{DDS}/2^{18}$$

$$f_M = R_{FM}[15:0]_{dec} \cdot f_{DDS}/2^{18}$$

Equivalently, values for R_FS[15:0] and R_FM[15:0] may be calculated from the desired carrier frequencies

$$R_{FS}[15:0]_{dec} = [2^{18} \cdot f_S/f_{DDS}]$$

$$R_{FM}[15:0]_{dec} = [2^{18} \cdot f_M/f_{DDS}]$$

With $f_{DDS} = 3$ MHz the direct digital synthesizer clock frequency and $[x]$ equal to x rounded to the nearest integer.

At the start of the transmission the DDS phase accumulator starts at 0, resulting in a 0 V output level. Switching between f_M and f_S is phase-continuous. Upon switching to receive mode the DDS completes the active sine period. These precautions minimize spurious emissions.

DA Converter and Anti-aliasing Filter

A digital to analogue $\Sigma\Delta$ converter converts the sine wave digital word to a pulse density modulated (PDM) signal. The PDM stream is converted to an analogue signal with a first order switched capacitor filter.

A 3rd order continuous time low pass filter in the transmit path filters the quantization noise and noise generated by the $\Sigma\Delta$ DA converter.

The -3 dB frequency of this filter can be set to 130 kHz for applications using the CENELEC A band. In this configuration, the response of the filter is virtually flat up to 95 kHz. Alternatively a -3 dB frequency of 195 kHz can be selected yielding a flat response for the entire CENELEC A to D band (i.e., up to 148.5 kHz). Refer to the documentation of the firmware for more information.

The low pass filter is tuned automatically to compensate for process variation.

Amplifier with Automatic Level Control (ALC)

The analogue output of the low-pass filter is buffered by a variable gain amplifier; 8 attenuation steps from 0 to -21 dB (typical) with steps of 3 dB are provided.

The attenuation can be fixed by setting the bit R_ALC_CTRL[3]. The embedded microcontroller can then set the attenuation using register ALC_CTRL[2:0]. This register is usually made available by the firmware to the application microcontroller. The attenuations corresponding to R_ALC_CTRL[2:0] values are given in Table 34.

Table 22. FIXED TRANSMITTER OUTPUT ATTENUATION

ALC_CTRL[2:0]	Attenuation
000	0 dB
001	-3 dB
010	-6 dB
011	-9 dB
100	-12 dB
101	-15 dB
110	-18 dB
111	-21 dB

Alternatively, automatic level control (ALC) may be used by clearing the bit R_ALC_CTRL[3].

In this mode, the signal on the analogue input pin ALC_IN controls the transmitter output level. First, peak detection is performed. The peak value is then compared to two threshold levels $V_{TL_ALC_IN}$ and $V_{TH_ALC_IN}$. Depending on the value of the measured peak level on ALC_IN the attenuation is updated using

$$V_{PALC_IN} < V_{TL_ALC}:$$

increase the level with one 3 dB step

$$V_{TL_ALC} \leq V_{PALC_IN} \leq V_{TH_ALC}:$$

do not change the attenuation

$$V_{PALC_IN} > V_{TH_ALC}:$$

decrease the level with one 3 dB step

The gain changes in the next chip clock. Therefore, an evaluation phase and a level adjustment phase take two CHIP_CLK periods. ALC operation is enabled only during the first 16 CHIP_CLK cycles after switching to transmit mode.

Following reset, the level is set at minimum level (maximum attenuation). When switching to reception mode

the last level is kept in memory. As a result the next transmit frame starts with the old level.

Note that the DC level on the ALC_IN pin is fixed internally to 1.65 V. As a result, a coupling capacitor is usually required.

If the automatic level control feature is not used, the pin ALC_IN may be left floating (not recommended) or tied to ground.

Transmitter Output TX_OUT

The transmitter output is DC coupled to the TX_OUT pin. Because the entire analogue part of the NCN49599 is referenced to the analogue reference voltage REF_OUT (about 1.65 V), a decoupling capacitor (C_1 in Figure 21) is usually required.

To suppress the second and third order harmonic of the generated S-FSK signal it is recommended to use a low pass filter. Figure 21 illustrates an MFB topology of a 2nd order filter.

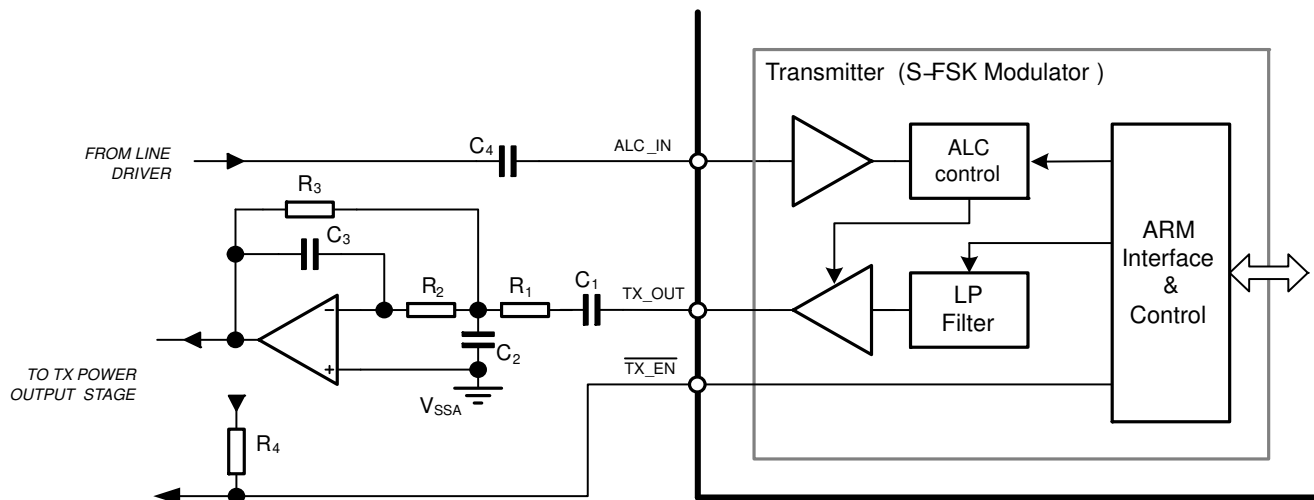

Figure 21. TX_OUT Filter

The modem indicates whether it is transmitting or receiving on the digital output pin TX_ENB. This is driven low when the transmitter is activated. The signal can be used to turn on an external line driver.

TX_ENB is a 5 V safe with open drain output; an external pull-up resistor must be added (Figure 21, R4).

When the modem switches from transmit to receive mode, TX_ENB is kept active (i.e., low) for a short period t_{dTX_ENB} (Figure 13).

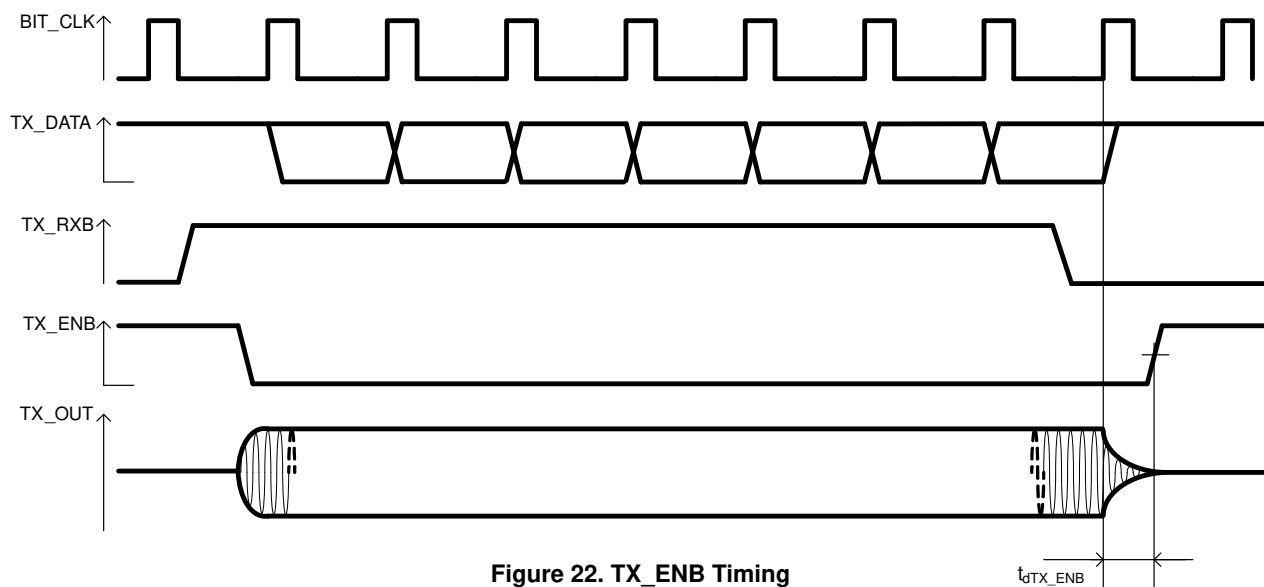

Figure 22. TX_ENB Timing

Power Amplifier

The NCN49599 integrates a high efficiency, Class A/B, low distortion power line driver. It is optimized to accept a signal from the modem part of the chip. The driver consists of two operational amplifiers (opamps).

The output opamp is designed to drive up to 1.2 A peak into an isolation transformer or simple coil coupling to the mains. At an output current of 1.5 A, the output voltage is guaranteed to swing within 1 V or less of either rail giving the user improved SNR.

In addition to the output amplifier, a small-signal opamp is provided which can be configured as a unity gain follower buffer or can provide the first stage of a 4-pole low pass filter.

The line driver offers a current limit, programmable with a single resistor, R-Limit, together with a current limit flag. The device has a thermal shutdown with hysteresis, triggered when the internal junction temperature exceeds 150°C.

The line driver has a power supply voltage range of 6–12 V. It can be shut down, leaving the outputs highly impedant.

Optimal stability and noise rejection, sufficient supply decoupling is required. Refer to the Supplies and Decoupling section for more information.

Coupling and Filtering

A typical coupling and filtering circuit is shown in Figure 24.

The power amplifier is enabled when ENB is low. In most applications TX_ENB is looped to ENB; an external pull up resistor is required.

Because the DC level on the TX_OUT pin equals the voltage on REF_OUT (nominally 1.65 V), a decoupling capacitor C_1 is needed when connecting it to the power amplifier.

To suppress the second and third order harmonic of the generated S-FSK signal it is recommended to use a 2nd or 3rd order low pass filter. Figure 24 shows an MFB topology of a 3rd order filter, designed for compliance with the European CENELEC EN 50056–1 standard for signaling on low-voltage electrical installations in the frequency range 3 kHz to 148.5 kHz.

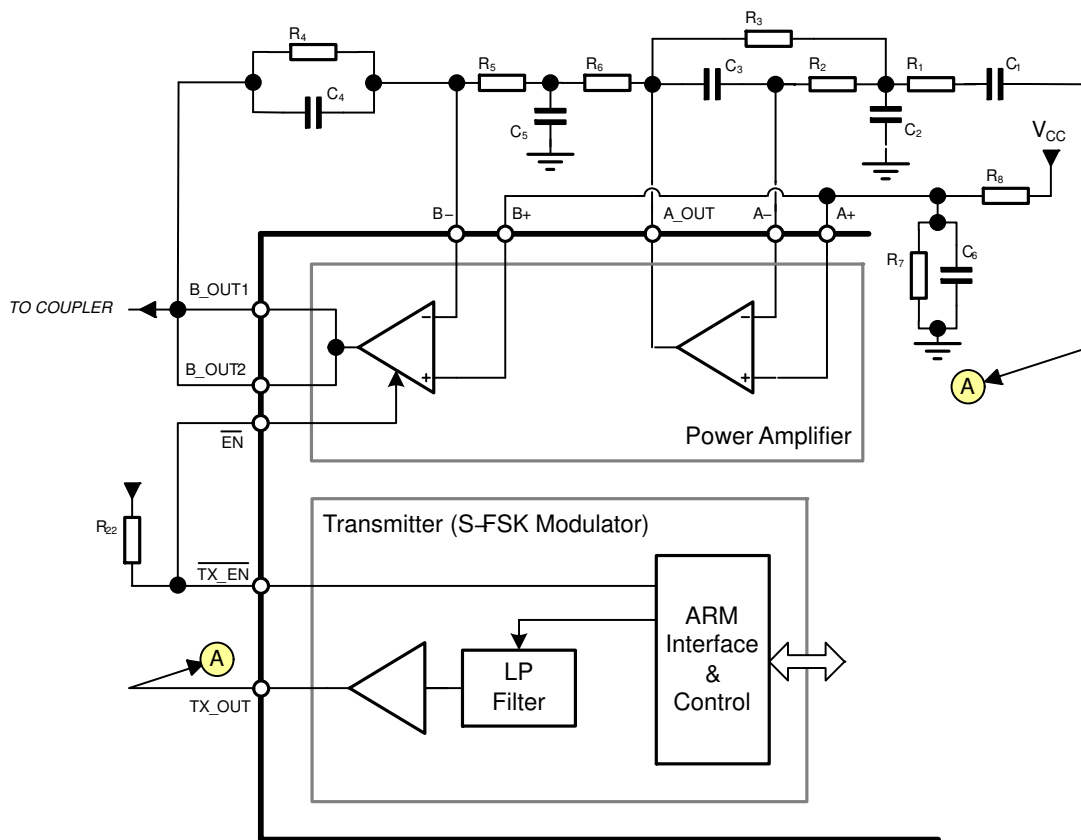

Figure 23. Power Amplifier Coupling and Filtering Current Protection

The maximal output current of the line driver in the NCN49599 can be programmed by the simple addition of a resistor (R_{LIM}) from RLIM (pin 4) to V_{EE} (Figure 25). Figure 26 shows the limiting value for given resistance, with a tolerance of ± 50 mA. Unlike traditional power amplifiers, the line driver in the NCN49599 current limit functions both while sourcing and sinking current. To calculate the resistance required to program a desired current limit the following equation can be used:

For correct operation in typical applications it is strongly recommended to set R_{LIM} to 5 k Ω . This ensures the current will not exceed 1.2 A causing damage. Refer also to the paragraph Safe operating area.

If the load current reaches the set current limit, the ILIM flag will go logic high. As an example, the user may act on this by reducing the signal amplitude.

When the current output recovers, the ILIM flag will return low.

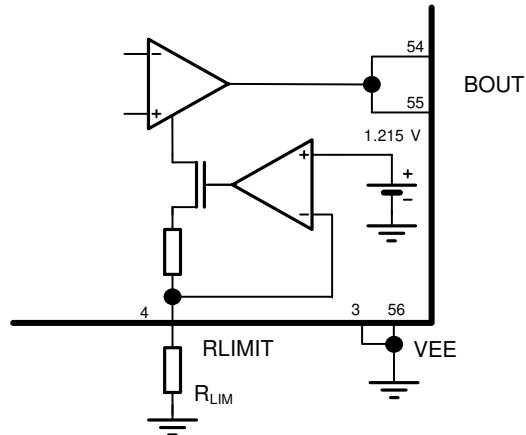

Figure 24. Programming the Current Limit

Figure 26 illustrates the required resistance to program the current limit.

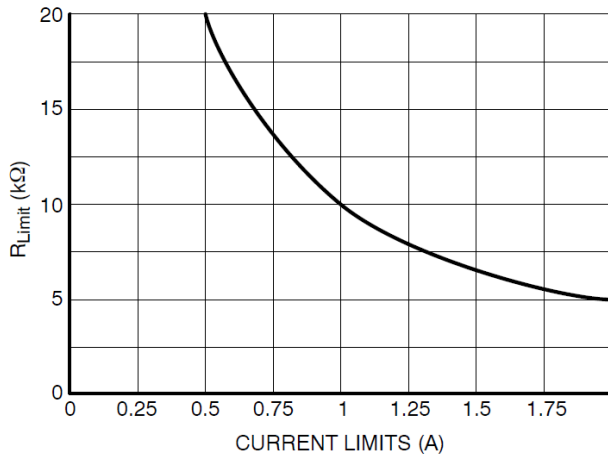

Figure 25. R_{LIM} in Function of the I_{LIM}

Thermal Protection

Excessive dissipation inside the amplifier, for instance during overload conditions, can result in damaging junction temperatures. A thermal shutdown protection monitors the junction temperature to protect against this.

When the internal junction temperature reaches approximately 160°C , the amplifier is disabled and placed in a high-impedance state. The amplifier will be re-enabled – assuming the Enable input is still active – when the junction temperature cools back down to approximately 135°C .

Safe Operating Area

The safe operating area (SOA) of an amplifier is the collection of output currents I_L and the output voltages V_L that will result in normal operation with risk of destruction due to overcurrent or overheating.

In a normal application only the output amplifier of the line driver must be considered; the load on the small-signal amplifier is usually negligible.

The output amplifier SOA depends on the thermal resistance from junction to ambient R_{thj-a} , which in turn strongly depends on board design. $R_{thj-a} = 50 \text{ K/W}$ in free air is a typical value, which may be used even if the host printed circuit board (PCB) is mounted in a small closed box, provided the transmission of frames are infrequent and widely spread in time.

This typical value is also used in the generation of the curves plotted in Figures 26 and 27.

Figure 27 shows the SOA in function of output current I_L and output voltage V_L with the ambient temperature as independent parameter. The maximum allowed current is 800 mA RMS. For that reason it is recommended to limit the output current by using $R_{LIM} = 5 \text{ k}\Omega$. This current limitation is plotted as a horizontal line. The maximal output voltage is limited by $V_{CC,max}$, V_{OH} and V_{OL} . This results in the straight line on the right hand side of the V_L-I_L plot. The area below and left from these limitations is considered as safe. The relation between output voltage and current is the impedance as seen at the output of the power operational amplifier. Constant impedance lines are represented by canted lines.

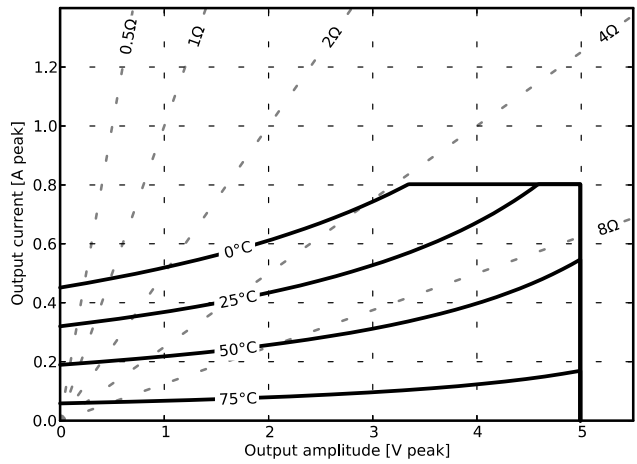

Figure 26. Example SOA in V_L-I_L space (bottom left corner is safe) with $R_{thj-a} = 50 \text{ K/W}$

Although voltage-versus-current is the normal representation of safe operating area, a PLC line driver can only control one of these variables: voltage and current are linked through the mains impedance. Figure 28 displays exactly the same information as Figure 27 but might be easier to work with. Constant current values are now represented as canted lines.

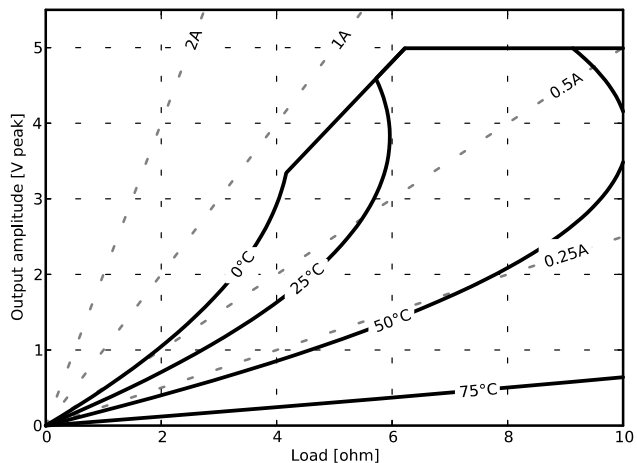

Figure 27. Example SOA in Z_L-V_L space (bottom right corner is safe)

Again, the safe operating area depends on PCB layout. Thus, the designer must verify the performance of her particular design [1].

Receiver Path Description

The receiver demodulates the signal on the communication channel. Typically, an external line coupling circuit is required to filter out the frequencies of interest on the communication channel.

The receiver block (Figure 29 and Figure 32) filters, digitalizes and partially demodulates the output signal of the coupling circuit. Subsequently, the embedded microcontroller core will demodulate the resulting digital stream. The demodulation is described in the fact sheets of the various firmware solutions.