



Chipsmall Limited consists of a professional team with an average of over 10 year of expertise in the distribution of electronic components. Based in Hongkong, we have already established firm and mutual-benefit business relationships with customers from,Europe,America and south Asia,supplying obsolete and hard-to-find components to meet their specific needs.

With the principle of “Quality Parts,Customers Priority,Honest Operation,and Considerate Service”,our business mainly focus on the distribution of electronic components. Line cards we deal with include Microchip,ALPS,ROHM,Xilinx,Pulse,ON,Everlight and Freescale. Main products comprise IC,Modules,Potentiometer,IC Socket,Relay,Connector.Our parts cover such applications as commercial,industrial, and automotives areas.

We are looking forward to setting up business relationship with you and hope to provide you with the best service and solution. Let us make a better world for our industry!



Contact us

Tel: +86-755-8981 8866 Fax: +86-755-8427 6832

Email & Skype: info@chipsmall.com Web: www.chipsmall.com

Address: A1208, Overseas Decoration Building, #122 Zhenhua RD., Futian, Shenzhen, China



NCN511010GEVB, NCN512010GEVB, NCN512110GEVB, NCN513010GEVB



ON Semiconductor®

www.onsemi.com

NCN51XX10GEVB Evaluation Board User's Manual

EVAL BOARD USER'S MANUAL

Introduction

The NCN51XX10GEVB Evaluation Board is the ideal solution for developing your KNX application with an ON Semiconductor KNX transceiver. The evaluation board contains the KNX transceiver which handles the transmission and reception of data on the bus. It will also generate all necessary voltages to power the board and external loads.

The NCN51XX10GEVB Evaluation Board assures safe coupling to and decoupling from the KNX bus. Bus monitoring warns the external microcontroller for loss of power so that critical data can be stored in time.

Features

- 9,600 baud KNX Communication Speed
- Supervision of KNX Bus Voltage
- High Efficient 1.2 V to 21 V Selectable DC-DC
- Converter to Drive External Loads
- Monitoring of Power Regulators
- No Additional Power Supply Required
- Buffering of Sent Data Frames (Extended Frames Supported)
- Selectable UART or SPI Interface to Host Controller
- Selectable UART and SPI Baud Rate to Host Controller
- Optional CRC on UART to the Host
- Optional MARKER Character to the Host
- Optional Direct Coupling of Rx/D and Tx/D to Host (Analog Mode)
- Auto Polling (Optional)
- Temperature Monitoring
- Operating Temperature Range of -40°C to $+105^{\circ}\text{C}$

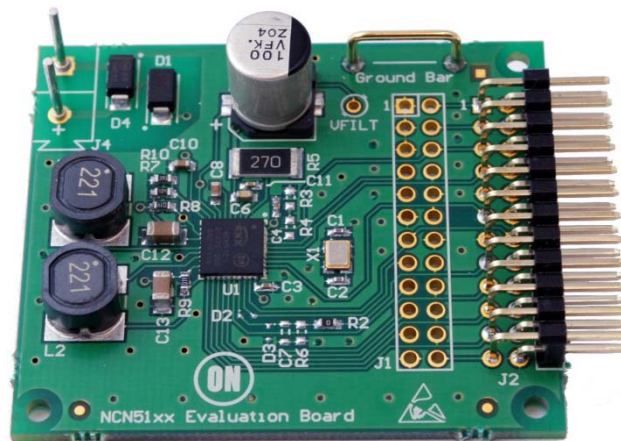

Figure 1. The NCN51XX10GEVB Evaluation Board

NCN511010GEVB, NCN512010GEVB, NCN512110GEVB, NCN513010GEVB

NCN51XX Description

The NCN51XX10GEVB provides an evaluation board for ON Semiconductor KNX transceivers that can be easily connected to a prototype design. Table 1 lists the available connectors on this board.

Table 1. CONNECTOR DESCRIPTION OF THE NCN51XX10GEVB BOARD

Connector	Description
J4	KNX Bus Connection
J2	Interface Connector
J1	Interface Connector (alternate)

Electrical Characteristics

Operating ranges define the limits for functional operation and parametric characteristics of the evaluation board. Note that the functionality of the evaluation board

outside these operating ranges is not guaranteed. Operating outside the recommended operating ranges for extended periods of time may affect device reliability.

Table 2. OPERATING RANGES

Symbol	Parameter	Min	Max	Units
V _{BUS}	Voltage on positive pin of J4 (Note 1)	+20	+33	V
V _{DIG}	Voltage on J1 (Pins 7, 8, 12, 13, 15–22) and J2 (Pins 7, 8, 11, 14–22)	0	+3.3	V
V _{ANA}	Output Voltage on J1 (Pin 6) or J2 (Pin 5)	0	+3.3	V
V _{DD1}	Output Voltage on J1 (Pin 24) or J2 (Pin 23)	0	+3.3	V
V _{DD2}	Output Voltage on J1 (Pin 2) or J2 (Pin 1) (Note 2)	0	+21	V
V _{20V}	Output Voltage on J1 (Pin 4) or J2 (Pin 3)	0	+22	V
T _a	Ambient Temperature	–40	+105	°C

1. Voltage indicates DC value. With equalization and active pulse, bus voltage must be between 11 V and 45 V
2. See Adjustable DC – DC Converter page 7 for the limitations!

NCN511010GEVB, NCN512010GEVB, NCN512110GEVB, NCN513010GEVB

NCN51XX10NGEVB Description Schematic Diagram – BOM List – PCB Layout

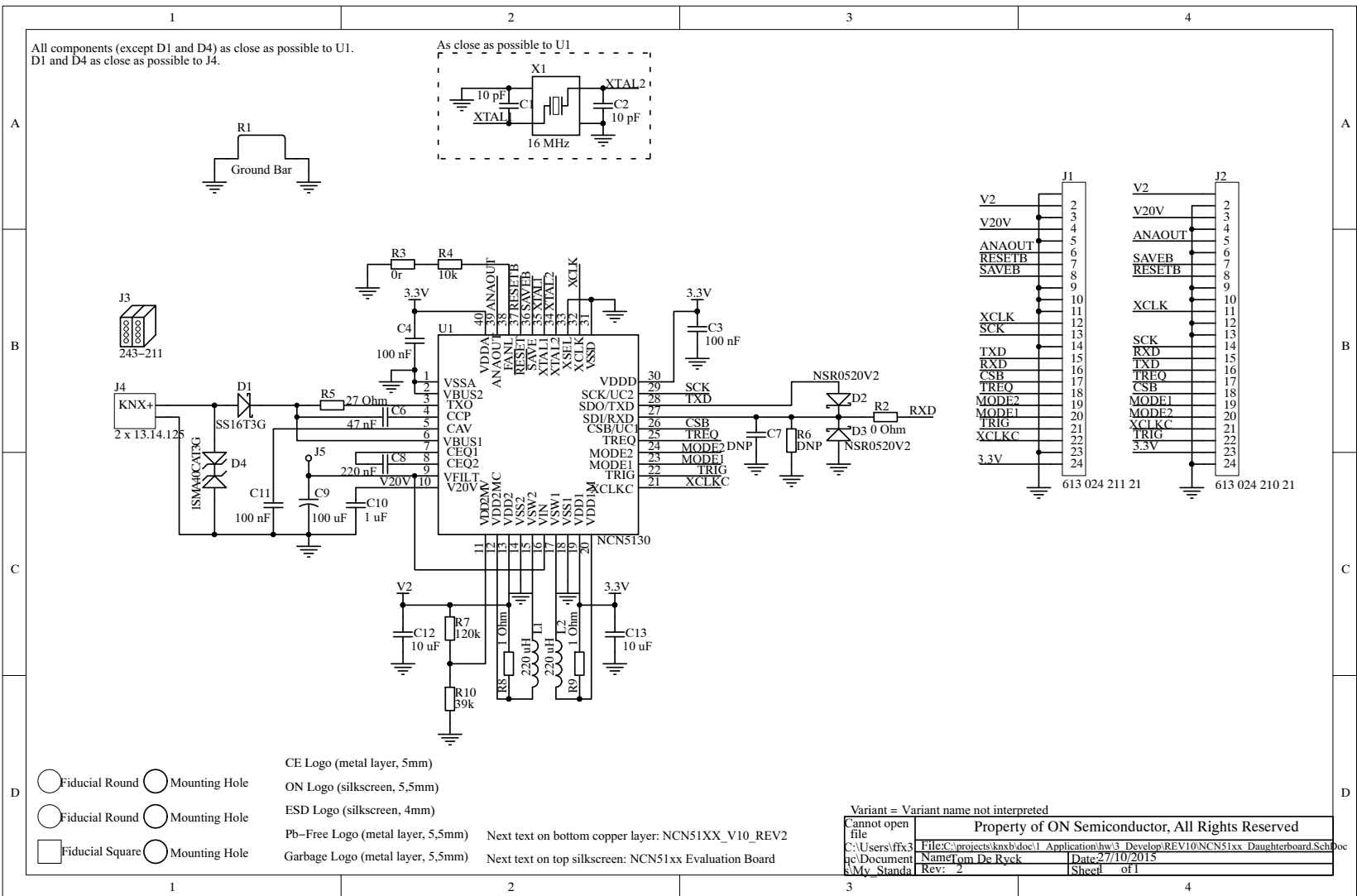

Figure 2. Schematic of NCN51XX10NGEVB

NCN511010GEVB, NCN512010GEVB, NCN512110GEVB, NCN513010GEVB

Table 3. NCN51XX10NGEVB BILL OF MATERIALS

Designator	Qty	Description	Value (NCN5110)	Value (NCN5120)	Value (NCN5121)	Value (NCN5130)
C1, C2	2	Multilayer Ceramic, COG, 50 V, ± 0 , 5 pF, 0402	DNP	10 pF		
C3, C4, C11	3	Multilayer Ceramic, X7R, 10 V, $\pm 10\%$, 0402	100 nF			
C6	1	Multilayer Ceramic, X7R, 50 V, $\pm 10\%$, 0603	47 nF			
C7			DNP			
C8	1	Multilayer Ceramic, X7R, 50 V, $\pm 10\%$, 0603	220 nF	4.7 nF	220 nF	
C9	1	SMD Electrolytic Capacitor, 35 V, $\pm 20\%$, 8x10	100 μ F			
C10	1	Multilayer Ceramic, X7R, 35 V, $\pm 10\%$, 0603	1 μ F			
C12, C13	2	Multilayer Ceramic, X7R, 25 V, $\pm 20\%$, 1206	10 μ F			
D1	1	1 A Schottky Rectifier, SMA	SS16T3G			
D2, D3			DNP			
D4	1	400 Watt SMA Transient Voltage Suppressor, 40 V Bidirectional, SMA	1SMA40CAT3G			
J2	1	WR-PHD Angled Pin Header, Dual Row, 24 Pins, 2,54 mm Pitch	Wurth Elektronik 613 024 210 21			
J3	1	EIB (KNX) Bus Coupler Unit Connector, Dark Grey and Red	Wago 243-211			
J4	1	EIB (KNX) Bus Coupler Unit Pins, 8,5 mm Length, 5,75 mm pitch	Ettinger 13.14.125			
L1, L2	2	WE-PD2SR SMD Shielded Power Inductor, 7,5x8,0	220 μ H			
R1	1	Shorting Link, Pitch 10.16 mm, Height 9 mm, Not-Isolated	0r			
R2		Thick Film Resistor, 100 mW, $\pm 5\%$, 0603	0r			
R3	1	Thick Film Resistor, 100 mW, $\pm 5\%$, 0603	0r	DNP		0r
R4	1	Thick Film Resistor, 100 mW, $\pm 1\%$, 0603	10k	DNP		10k
R5	1	Thick Film Resistor, 1 W, $\pm 5\%$, 2512	27r	22r	27r	
R7	1	Thick Film Resistor, 100 mW, $\pm 5\%$, 0603	120k	33k	120k	
R6			DNP			
R8, R9	2	Thick Film Resistor, 100 mW, $\pm 1\%$, 0603	1r			
R10	1	Thick Film Resistor, 100 mW, $\pm 5\%$, 0603	39k	180k	39k	
U1	1	ON Semiconductor KNX Transceiver, NQFP-40	NCN5110	NCN5120	NCN5121	NCN5130
X1	1	Crystal, SMD, 4 Pins, 3,2 x 2,5 mm	DNP	16 MHz		

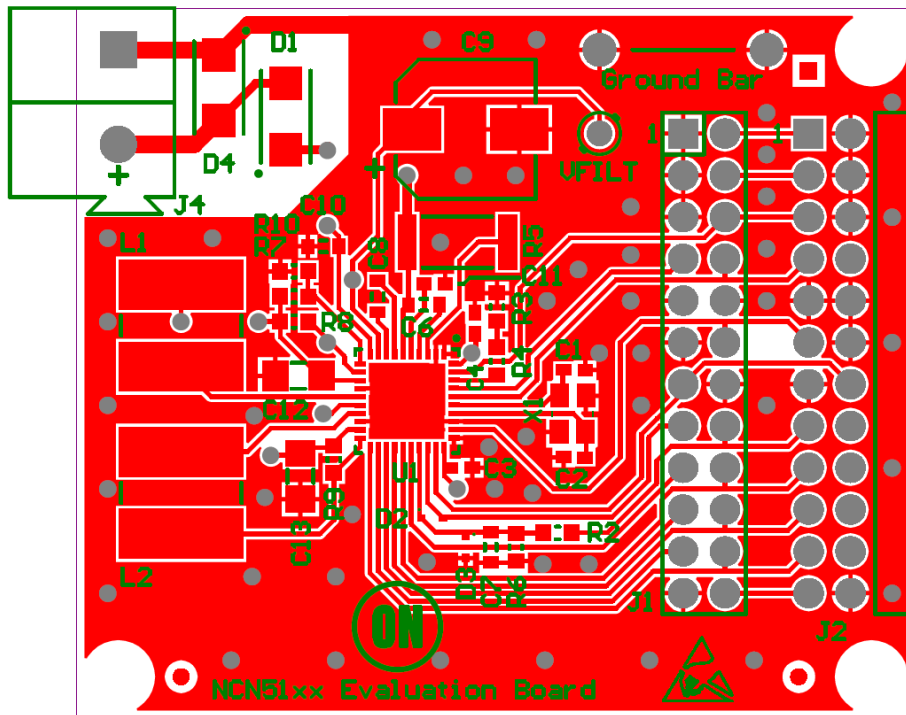

Figure 3.Top Layer Layout

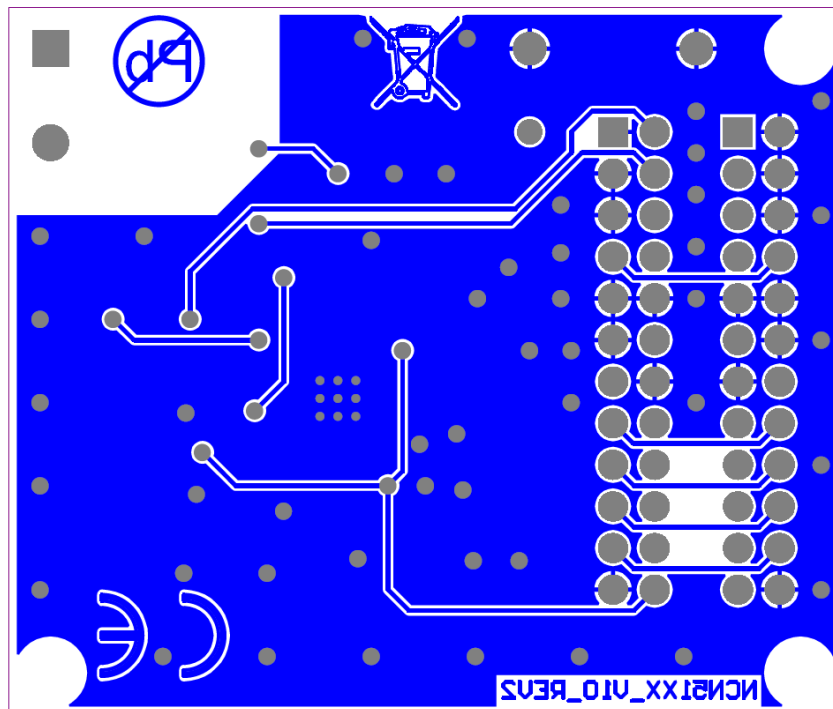

Figure 4.Bottom Layer Layout

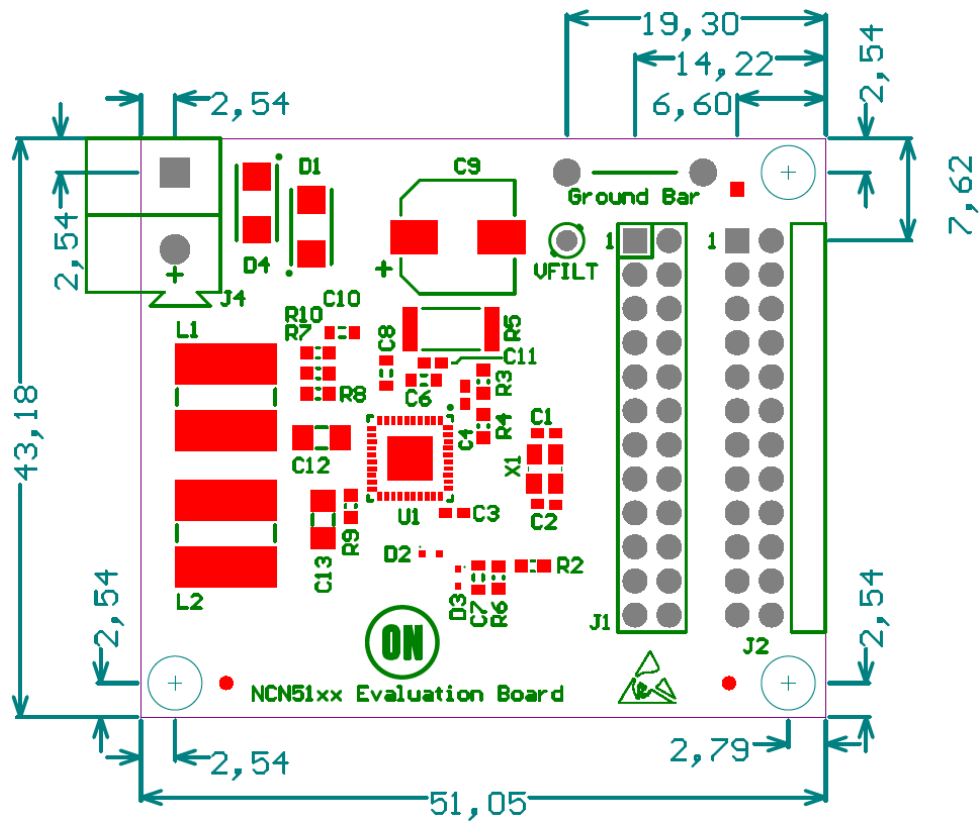

Figure 5.PCB Dimensions

General Overview

Because the NCN5120 Development Board contains a KNX Certified KNX Transceiver no further details on KNX will be given in this document. Detailed information on the ON Semiconductor Certified KNX Transceivers can be found in the NCN5110/NCN5120/NCN5121/NCN5130 datasheets (www.onsemi.com). Detailed information on the KNX Bus can be found on the KNX website and in the KNX standards (www.knx.org).

KNX Bus Connection

Connection to the KNX bus is done by means of J4. A standard Wago connector (type 243 – 211) can be used for this (see Figure 6). A reverse protection diode (D1, Figure 2)

is foreseen (mandatory) as also a Transient Voltage Suppressor (D2, Figure 2). Minimum VBUS is 20 V (see KNX standard).

IBUS is limited by the transceiver, as well as the rate of change of IBUS. This limitation is required by the KNX standard.

If the FANIN pin is open, IBUS can maximum be 12 mA and change at 0.5 mA/ms. If the FANIN pin is shorted to ground, IBUS can maximum be 24 mA and change at 1 mA/ms. For NCN5110 and NCN5130, the FANIN pin can also have a resistance to ground to set the current limit to any value between 6mA and 47 mA, with an associated current slope limitation of 0.23 mA/ms to 1.95 mA/ms.



Figure 6.KNX Bus Connector

NCN511010GEVB, NCN512010GEVB, NCN512110GEVB, NCN513010GEVB

Power Supplies

The KNX transceiver provides the power from the bus for the complete application. The evaluation board will provide the following voltages to the application.

V_{FILT}

This is an unregulated voltage resulting on a buffer capacitance, after observing the bus current (slope) limits. All other voltages are derived from this voltage. If the application has sharp load transients on any voltage rail, enough buffer capacitance must be placed on *V_{FILT}*. See the datasheet for more information.

V_{20V}:

This is a linear regulated +20 V. Since this voltage is derived from *V_{FILT}*, it may be that this voltage is lower than 20 V when the bus voltage is low or when during a load transient *V_{FILT}* drops below 20 V. For more information on this rail and the current limit, see the datasheet.

+3V3

A +3V3 is provided from one DCDC convertor. This voltage is also used as the supply for the transceiver. Although *V_{DD2}* is capable of delivering 100 mA, the maximum current capability will not always be usable. One needs to make sure that the KNX bus power consumption stays within the KNX specification.

V_{DD2}

This is a second power supply which can be used to drive external loads. The voltage is programmable between 1.2 V (NCN5110/NCN5121/NCN5130) or 3.3 V (NCN5120) and 21 V by means of an external resistor divider (R7 and R10, see Figure 2).

The voltage divider can be calculated as follows for NCN5120:

$$R_7 = \frac{R_{10} \times R_{VDD2M}}{R_{10} + R_{VDD2M}} \times \frac{V_{DD2} - 3.3}{3.3}$$

R_{VDD2M} is between 60 k and 140 k (typical 100 k).

The voltage divider can be calculated as follows for NCN5110/NCN5121/NCN5130:

$$R_7 = R_{10} \times \frac{V_{DD2} - 1.2}{1.2}$$

The DC value of the *V_{FILT}* line should be higher than *V_{DD2}*.

Although *V_{DD2}* is capable of delivering 100 mA, the maximum current capability will not always be usable. One needs to make sure that the KNX bus power consumption stays within the KNX specification.

Crystal Oscillator

A crystal of 16 MHz (X1, see Figure 11) is foreseen on the development board. This clock signal is also supplied to the microcontroller. As the clock signal is only used for digital services, the NCN5110 does not require a crystal. See the datasheet (www.onsemi.com) for more details on this block.

Interface

The device can communicate with the host controller by means of a UART interface or an SPI interface. The selection of the interface and communication speed is done by the pins *MODE1*, *MODE2*, *TREQ*, *SCK/UC2* and *CSB/UC1* which can be pulled up or down, or connected to the microcontroller. More details on the different interfaces can be found in the datasheet.

Monitoring

RESETB and SAVEB

The KNX transceiver controls the reset state of the microcontroller by means of the *RESETB* signal. An additional *SAVEB* signal can be monitored by the microcontroller to detect possible issues. See datasheet for more details on these two signals.

Voltage Supervisors

On Semiconductor KNX transceivers have different voltage supervisors, which can be read out through registers. Please check the datasheet for more details.

Temperature Monitor

The transceiver produces an over-temperature warning (*TW*) and a thermal shutdown warning (*TSD*), which can be read out through registers. Please check the datasheet for more details.

NCN511010GEVB, NCN512010GEVB, NCN512110GEVB, NCN513010GEVB

FAQ

1. Is this development board KNX Certified?

No, only the transceiver is KNX Certified. The development board may only be used for evaluation of the transceiver. It is not allowed to use the development board in a final product or to sell it as a KNX Certified product. Contact ON Semiconductor if you want to use the development board as a final product.

2. What 3rd party companies do you recommend for the higher layer stacks?

ON Semiconductor does not recommend any 3rd party company in particular. Several 3rd party companies have KNX Certified stacks and it's always advised to use one of these stacks. Some companies have experience with ON Semiconductor KNX transceivers. Contact ON Semiconductor for more information.

3. Can we freely reuse the schematic and layout of this development board?

It is allowed to reuse the schematic, components and layout of the evaluation board for your own application. Because the operating conditions of your design are not known by ON Semiconductor, one must always fully verify the design even if it's based on this evaluation board. Contact ON Semiconductor if additional information is required.

4. Can we request ON Semiconductor to supply the higher layer stacks?

By no means will ON Semiconductor provide any higher layer stacks. Certified higher layer stacks can be provided by 3rd party companies.

5. How much load can the outputs drive?

The maximum allow load can be calculated with the formula as given in Adjustable DC-DC Converter (page x13). IDD2 defines the maximum load the outputs can drive in total.

6. Is it possible to test all interfaces (UART, SPI, Analog Mode) with this evaluation board?

Yes, the board can be used with all possible interfaces. One has to be careful however when using the Analog Mode. In the Analog Mode the digital of NCN5120 is bypassed. If the microcontroller would force the RXD – pin (pin 29) high, the transceiver would pull the KNX bus low continuously, which could lead to issues.

7. I'm having issues with the voltage regulators whenever I'm going above a certain current. What could be the issue?

To be able to take more than 13 mA from the KNX bus one needs to pull the FANIN – pin of NCN5120 low. This can be done by shorting J5 (add jumper). See datasheet for more info on the FANIN – pin.

Additionally, there is a current limit on V20/3V3/VDD2

ON Semiconductor and the  are registered trademarks of Semiconductor Components Industries, LLC (SCILLC) or its subsidiaries in the United States and/or other countries. SCILLC owns the rights to a number of patents, trademarks, copyrights, trade secrets, and other intellectual property. A listing of SCILLC's product/patent coverage may be accessed at www.onsemi.com/site/pdf/Patent-Marking.pdf. SCILLC reserves the right to make changes without further notice to any products herein. SCILLC makes no warranty, representation or guarantee regarding the suitability of its products for any particular purpose, nor does SCILLC assume any liability arising out of the application or use of any product or circuit, and specifically disclaims any and all liability, including without limitation special, consequential or incidental damages. "Typical" parameters which may be provided in SCILLC data sheets and/or specifications can and do vary in different applications and actual performance may vary over time. All operating parameters, including "Typicals" must be validated for each customer application by customer's technical experts. SCILLC does not convey any license under its patent rights nor the rights of others. SCILLC products are not designed, intended, or authorized for use as components in systems intended for surgical implant into the body, or other applications intended to support or sustain life, or for any other application in which the failure of the SCILLC product could create a situation where personal injury or death may occur. Should Buyer purchase or use SCILLC products for any such unintended or unauthorized application, Buyer shall indemnify and hold SCILLC and its officers, employees, subsidiaries, affiliates, and distributors harmless against all claims, costs, damages, and expenses, and reasonable attorney fees arising out of, directly or indirectly, any claim of personal injury or death associated with such unintended or unauthorized use, even if such claim alleges that SCILLC was negligent regarding the design or manufacture of the part. SCILLC is an Equal Opportunity/Affirmative Action Employer. This literature is subject to all applicable copyright laws and is not for resale in any manner.

PUBLICATION ORDERING INFORMATION

LITERATURE FULFILLMENT:

Literature Distribution Center for ON Semiconductor
19521 E. 32nd Pkwy, Aurora, Colorado 80011 USA
Phone: 303-675-2175 or 800-344-3860 Toll Free USA/Canada
Fax: 303-675-2176 or 800-344-3867 Toll Free USA/Canada
Email: orderlit@onsemi.com

N. American Technical Support: 800-282-9855 Toll Free
USA/Canada
Europe, Middle East and Africa Technical Support:
Phone: 421 33 790 2910
Japan Customer Focus Center
Phone: 81-3-5817-1050

ON Semiconductor Website: www.onsemi.com

Order Literature: <http://www.onsemi.com/orderlit>

For additional information, please contact your local Sales Representative