



Chipsmall Limited consists of a professional team with an average of over 10 year of expertise in the distribution of electronic components. Based in Hongkong, we have already established firm and mutual-benefit business relationships with customers from,Europe,America and south Asia,supplying obsolete and hard-to-find components to meet their specific needs.

With the principle of “Quality Parts,Customers Priority,Honest Operation,and Considerate Service”,our business mainly focus on the distribution of electronic components. Line cards we deal with include Microchip,ALPS,ROHM,Xilinx,Pulse,ON,Everlight and Freescale. Main products comprise IC,Modules,Potentiometer,IC Socket,Relay,Connector.Our parts cover such applications as commercial,industrial, and automotives areas.

We are looking forward to setting up business relationship with you and hope to provide you with the best service and solution. Let us make a better world for our industry!



## Contact us

Tel: +86-755-8981 8866 Fax: +86-755-8427 6832

Email & Skype: info@chipsmall.com Web: www.chipsmall.com

Address: A1208, Overseas Decoration Building, #122 Zhenhua RD., Futian, Shenzhen, China



# NCN5150NGEVB

## NCN5150 Evaluation Board User's Manual



**ON Semiconductor®**

<http://onsemi.com>

### EVAL BOARD USER'S MANUAL

#### Introduction

The NCN5150SOICGEVB and NCN5150QFNGEVB evaluation boards demonstrate the NCN5150 M-BUS transceiver in SOIC and QFN package respectively. These evaluation boards include all external components needed for operating NCN5150 and demonstrate the small PCB surface area such an implementation requires.

#### Overview

The NCN5150 is a single-chip integrated slave transceiver for use in two-wire Meter Bus (M-BUS) slave devices and repeaters. The transceiver provides all of the functions needed to satisfy the European Standards EN 13757-2 and EN 1434-3 describing the physical layer requirements for M-BUS. It includes a programmable power level of up to 2 (SOIC version) or 6 (NQFP version) unit loads, which are available for use in external circuits through a 3.3 V LDO regulator. The NCN5150 can provide communication up to the maximum M-BUS communication speed of 38,400 baud (half-duplex).

#### Applications

Multi-energy Utility Meters

- Water
- Gas
- Electricity
- Heating Systems

#### Features

- Single-chip MBUS Transceiver
- UART Communication Speeds Up to 38,400 baud

- Integrated 3.3 V VDD LDO Regulator with Extended Peak Current
- Capability of 15 mA
- Supports Powering Slave Device from the Bus or from External Power Supply
- Adjustable I/O Levels
- Adjustable Constant Current Sink up to 2 or 6 Unit Loads Depending on the Package
- Low Bus Voltage Operation
- Extended Current Budget for External Circuits: minimum 0.8 mA
- Polarity Independent
- Power-Fail Function
- Fast Startup – No External Transistor Required on STC Pin
- Industrial Ambient Temperature Range of  $-40^{\circ}\text{C}$  to  $+85^{\circ}\text{C}$
- Available in:
  - ♦ 16-pin SOIC (Pin-to-Pin Compatible with TSS721A)
  - ♦ 20-pin QFN
- These are Pb-free Devices

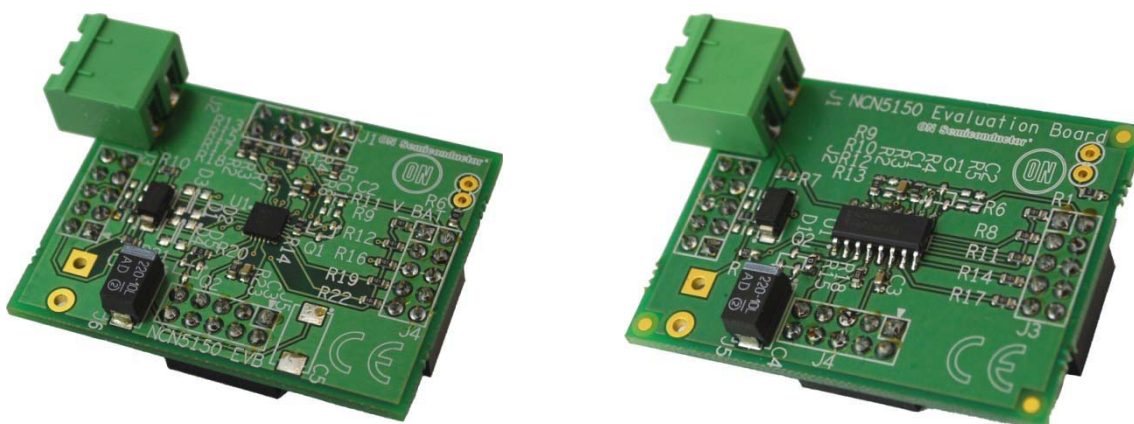

Figure 1. The NCN5150NGEVB Evaluation Boards

# NCN5150NGEVB

## ELECTRICAL CHARACTERISTICS

**Table 1. ELECTRICAL CHARACTERISTICS OF THE NCN5150SOICGEVB AND NCN5150QFNGEVB BOARD**

Symbol	Parameter / Condition	Value			Unit
		Min	Typ	Max	
<b>Bus Voltage</b>					
$V_{BUS}$	Bus Voltage	12	36	42	V
<b>Current Drawn from the Bus</b>					
$I_{BUS}$	1 UL		1.3	1.5	mA
<b>Output Voltage</b>					
$V_{DD}$	LDO output	3.1	3.3	3.6	V

### NCN5150 DESCRIPTION

The NCN5150 provide a complete transceiver for the Metering Bus (M-BUS). It consists of a transmit block which will translate the logic level uart input to current level signaling on the bus, and a receive block which will translate the voltage-level signaling on the bus to a logic-level uart output. The device includes an echo function which will echo the uart input on the uart output, provided the device is powered. This can be used by the software stack to monitor if the message was transmitted. The high voltage level of the microcontroller interface can be changed by connecting the desired voltage to the VIO pin. By default, this pin is

connected through a 0R resistor to 3.3 V on the evaluation boards.

A constant current regulator that will draw a fixed current from the bus, expressed in unit loads (UL). This current is made available to the application through a low-dropout 3.3 V regulator. The NCN5150 will detect when the bus is disconnected and provide an early warning to the microcontroller that the 3.3 V supply is about to collapse through the Pfb pin.

A thermal shutdown protects the device against high junction temperatures.

### NCN5150SOICGEVB DESCRIPTION

#### General Overview

The NCN5192NGEVB evaluation board demonstrates the external components required for the operation of the IC.

We will cover the different sections below as well as possible alternatives. A drawing of the board where the different sections are indicated is shown below.

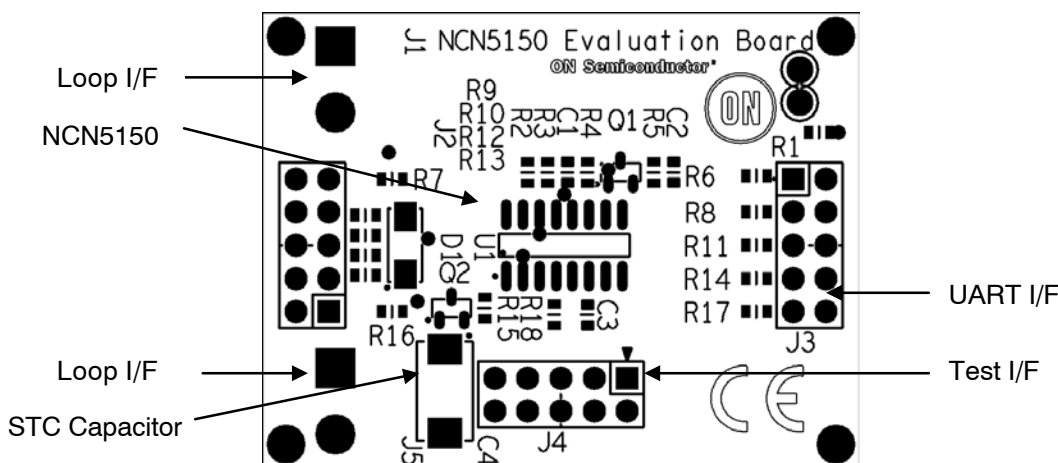

**Figure 2. Board Drawing with Indication of Different Sections**

# NCN5150NGEVB

## BOM List

**Table 2. NCN5150SOICGEVB BILL OF MATERIALS**

Quantity	Reference	Part	Footprint	Comments	Manufacturer	Product Code
1	C1	1u	C0603	6V3	Multicomp	MCCA000515
1	C2	DNP	C0603	DNP	-	-
5	R3, R5, R9, R12, R13	DNP	R0603	DNP	-	-
1	C3	100n	C0603	50 V	Multicomp	MCCA000256
1	C4	220u	Case E	10 V	AVX	TAJD227K010RNJ
1	D1	1SMA40CAT3G	SMA		ON Semiconductor	1SMA40CAT3G
2	J1,J5	CON2		DNP	IMO Precision	21.95MH/2
3	J2,J3,J4	CON10A		DNP	Multicomp	2214S-10SG-85
2	Q1,Q2	DNP	SOT-23	DNP	-	-
4	R1, R4, R10, R15	0R	R0603	62.5 mW	Multicomp	MC0603WG00000T5E-TR
6	R2, R6, R8, R11, R14, R17	100R	R0603	62.5 mW	Multicomp	MC0.063W06031%100RFR
2	R7, R16	220R	R0603	62.5 mW	Multicomp	MC0.063W06031%220RFR
1	R18	30K	R0603	62.5 mW	Multicomp	MC0.063W06031%30KFR
1	TP1	GND		DNP	-	-
1	TP2	3V3		DNP	-	-
1	U1	NCN5150	SOIC16	DNP	ON Semiconductor	NCN5150DR2G

# NCN5150NGEVB

## Schematic Diagram

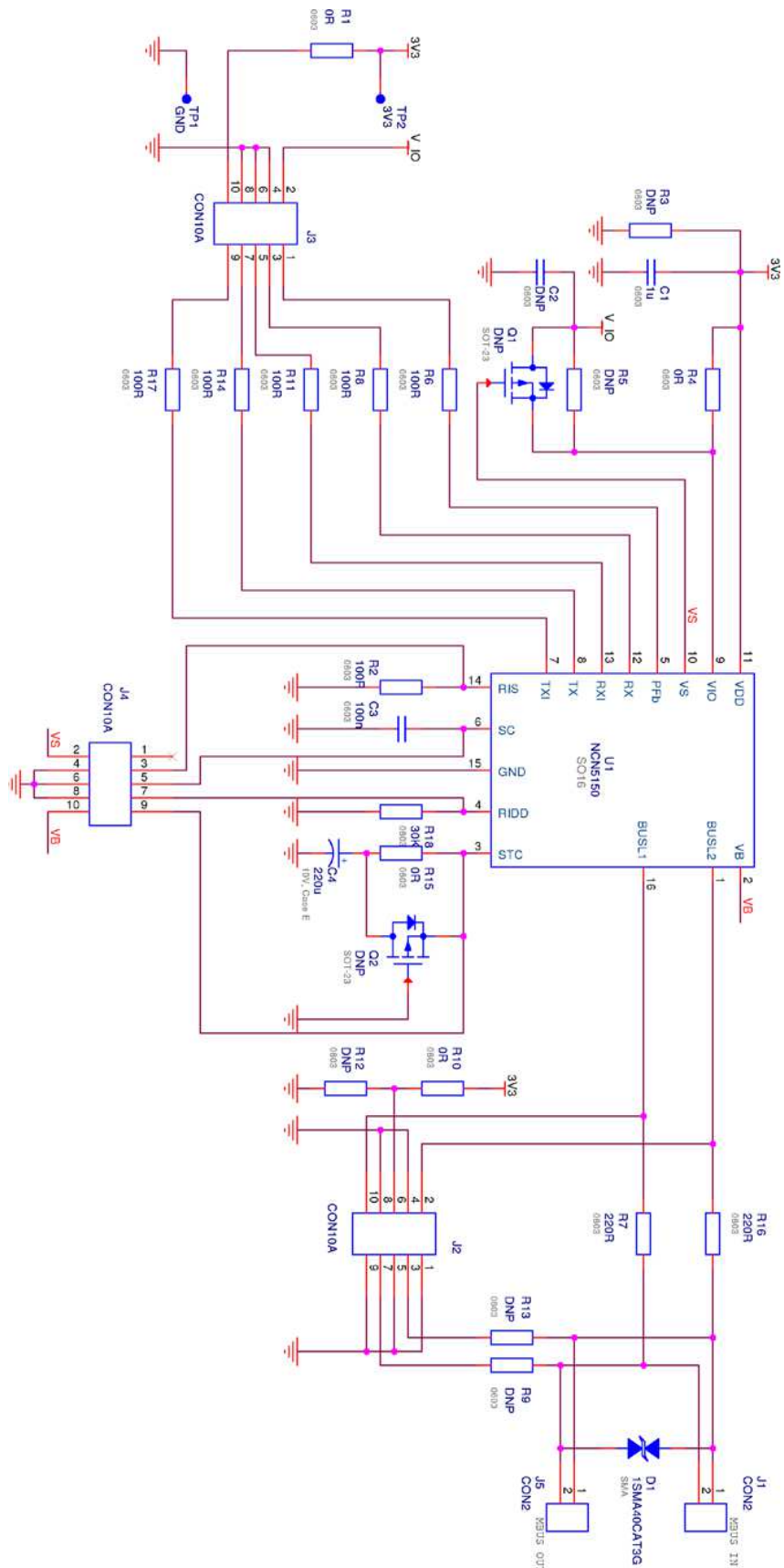

Figure 3. Schematic of NCN5150SOICGEVB

# NCN5150NGEVB

## NCN5150QFNGEVB DESCRIPTION

### General Overview

The NCN5150QFNGEVB evaluation board demonstrates the external components required for the operation of the IC. We will cover the different sections

below as well as possible alternatives. A drawing of the board where the different sections are indicated is shown below.

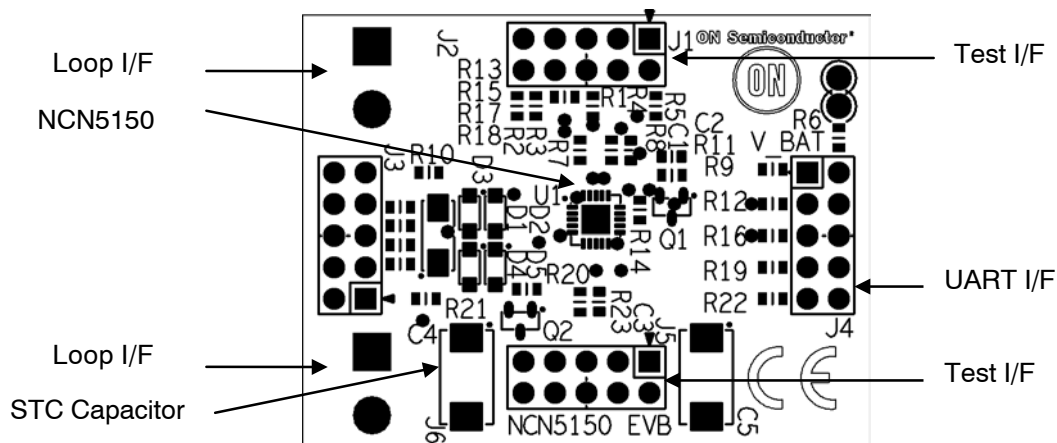

Figure 4. Board Drawing with Indication of Different Sections

### BOM List

Table 3. NCN5150QFNGEVB BILL OF MATERIALS

Quantity	Reference	Part	Footprint	Comments	Manufacturer	Product Code
1	C1	1u	C0603	6.3 V	Multicomp	MCCA000515
1	C2	DNP	C0603	DNP	-	-
1	C3	100n	C0603	50 V	Multicomp	MCCA000256
1	C4	220u	Case E	10 V	AVX	TAJD227K010RNJ
1	C5	DNP	Case E	DNP	-	-
4	D1, D2, D4, D5	DNP	SOD-123	DNP	-	-
1	D3	1SMA40CAT3G	SMA		ON Semiconductor	1SMA40CAT3G
4	J1, J3, J4, J5	CON10A		DNP	IMO Precision	21.95MH/2
2	J2, J6	CON2		DNP	Multicomp	2214S-10SG-85
2	Q1, Q2	DNP	SOT-23	DNP	-	-
10	R1,R2,R3,R4,R5, R8,R11,R13,R15, R18	DNP		DNP	-	-
6	R7,R9,R12,R16, R19,R22	100R	R0603	62.5 mW	Multicomp	MC0.063W06031%100RFR
4	R6,R14,R17,R20	0R	R0603	62.5 mW	Multicomp	MC0603WG00000T5E-TR
2	R10, R21	220R	R0603	62.5 mW	Multicomp	MC0.063W06031%220RFR
1	R23	30K	R0603	62.5 mW	Multicomp	MC0.063W06031%30KFR
1	TP1	GND		DNP	-	-
1	TP2	3V3		DNP	-	-
1	U1	NCN5150	QFN20	ON Sample	ON Semiconductor	NCN5150MNTWG

Schematic Diagram

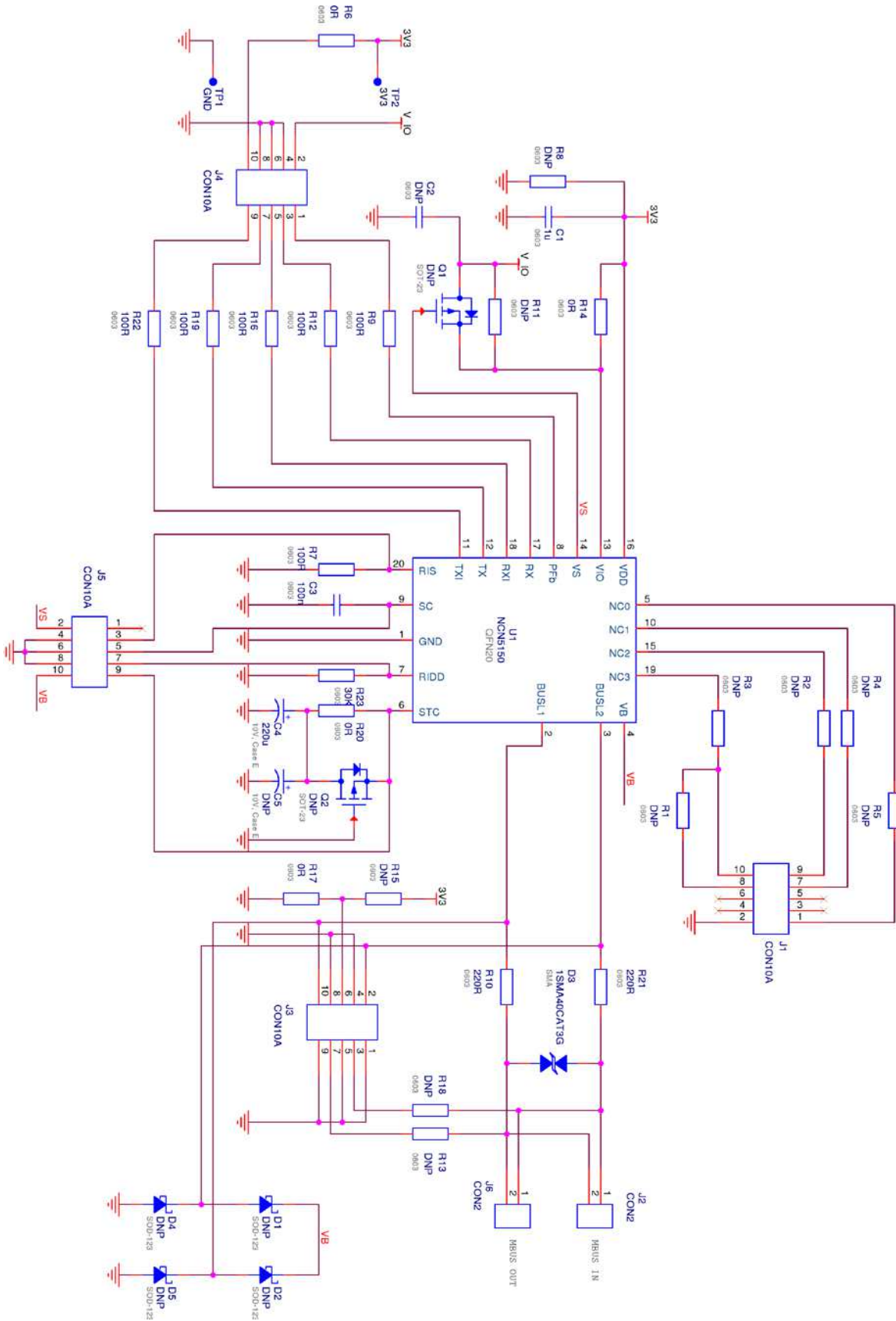

Figure 5. Schematic of NCN5150QFNGEVB

# NCN5150NGEVB

## FUNCTIONAL DESCRIPTION

### Power Supply

The NCN5150 provides power to be used in the application. To do this, the NCN5150 draws a fixed current from the bus. The amount of current drawn is fixed at a number of unit loads (intervals of 1.5 mA) and can be set by changing the value of the RIDD resistor. The SOIC version can support up to 2 UL, while the QFN version can support up to 6 UL. The required resistors for are shown in table xx.

Also shown in table xx is the maximum amount of capacitance allowed on the STC pin. This limit will ensure that the transceiver will start up in less than 3 s as required by the M-BUS standard. Using a smaller capacitor on STC is allowed, and will result in faster start-up, but also in a faster shutdown, reducing the time between the early warning Pfb toggling (when the bus is removed) and the point where the 3.3V VDD voltage can no longer be maintained. The minimum allowed capacitance on STC is 10 times the capacitance on the VDD pin. The minimum required capacitance on the VDD pin is 1  $\mu$ F.

**Table 4. UL, RIDD VALUES, STC CAPACITANCE**

Number of Unit Loads	RIDD Value	Maximum STC Capacitor Value	Min. Available Current
1	30 k $\Omega$	330 $\mu$ F	0.88 mA
2	13 k $\Omega$	820 $\mu$ F	2.10 mA
3	8.45 k $\Omega$	1200 $\mu$ F	3.10 mA
4	6.19 k $\Omega$	1500 $\mu$ F	4.20 mA
5	4.87 k $\Omega$	2200 $\mu$ F	5.30 mA
6	4.02 k $\Omega$	2700 $\mu$ F	6.50 mA

Shown in Figure 6 is the startup sequence of the device. Note that the NCN5150 does not require any external (PMOS) transistor on the STC pin for proper startup. The yellow waveform is the bus voltage, the purple waveform the STC voltage, the green waveform the VDD output, and the blue waveform the TX output.



**Figure 6. NCN5150 Startup Sequence**

Shown in Figure 7 is the shutdown sequence of the device. The green waveform is the bus voltage, the blue waveform

is the VDD output, the purple waveform is the Pfb output, and the yellow waveform is the TX output.



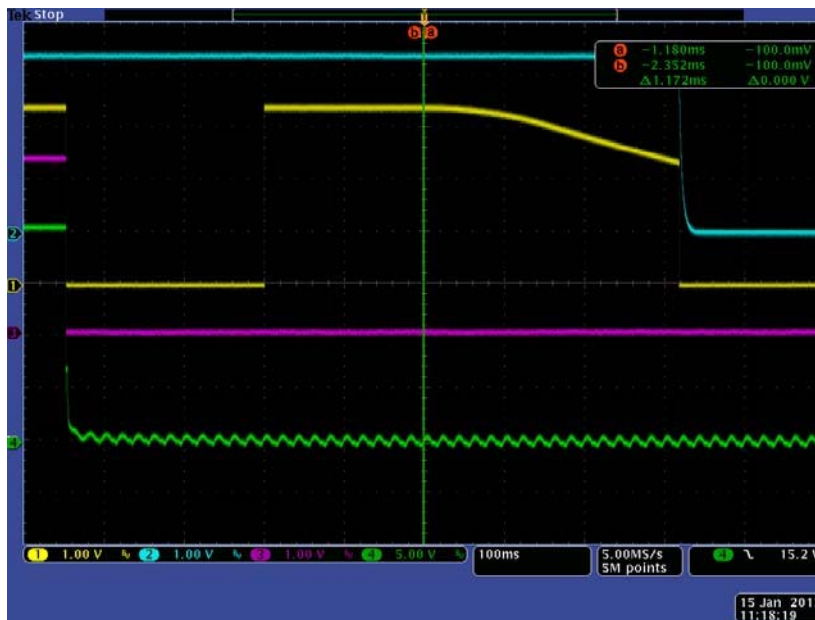

Figure 7. NCN5150 Shutdown Sequence

**UART Interface IDC1**

The interface between the transceiver and an external microcontroller is a standard uart interface consisting of the TX and RX. Alternatively, inverted signals, TXI and RXI, which are active high, are also available. Only one signal from TX and TXI, or from RX and RXI can be used at the same time. The uart pins can handle communication up to 38400 baud. The M-BUS standard requires communication with 1 start bit, 8 data-bits, 1 even parity bit and 1 stop bit.

Also available on the same connector is the VIO connection, PFb indication and 3V3 VDD output.

**Table 5. MICROCONTROLLER INTERFACE**

Pin number	Signal	Type	Description
1	PFb	Output	Bus failure indication
2	VIO	Power	IO voltage level
3	RX	Input	UART input
5	RXI	Input	UART input, inverted
7	TX	Output	UART output
9	TXI	Output	UART output, Inverted
4, 6, 8	GND	Power	Ground
10	VDD	Power	3V3 Output

**Transmitter**

The M-Bus transmitter translated the RX or RXI voltage levels to current levels on the bus. Typically, 15 mA is added when transmitting a space.

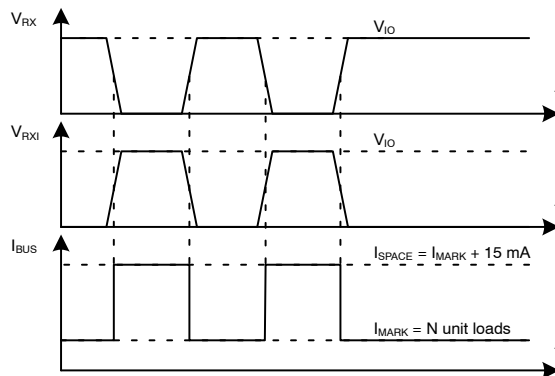

Figure 8. Output Waveforms

**Receiver**

The receiver will compare the bus voltage level with the mark level stored on the SC capacitor minus the threshold level (typically 6 V). It will translate these voltage levels to low voltage communication on the TX and TXI pins. The high voltage of these pins is determined by the VIO voltage.

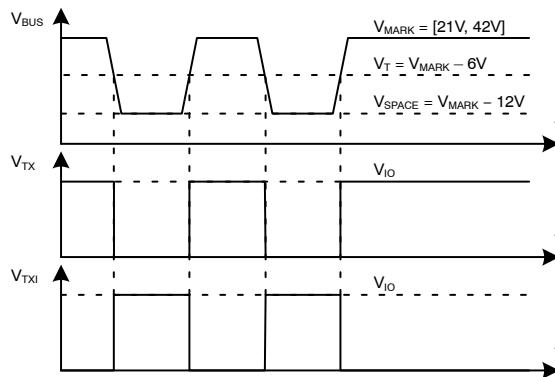

Figure 9. Receive Waveforms

# NCN5150NGEVB

## APPENDIX

### Evaluation Board Layout

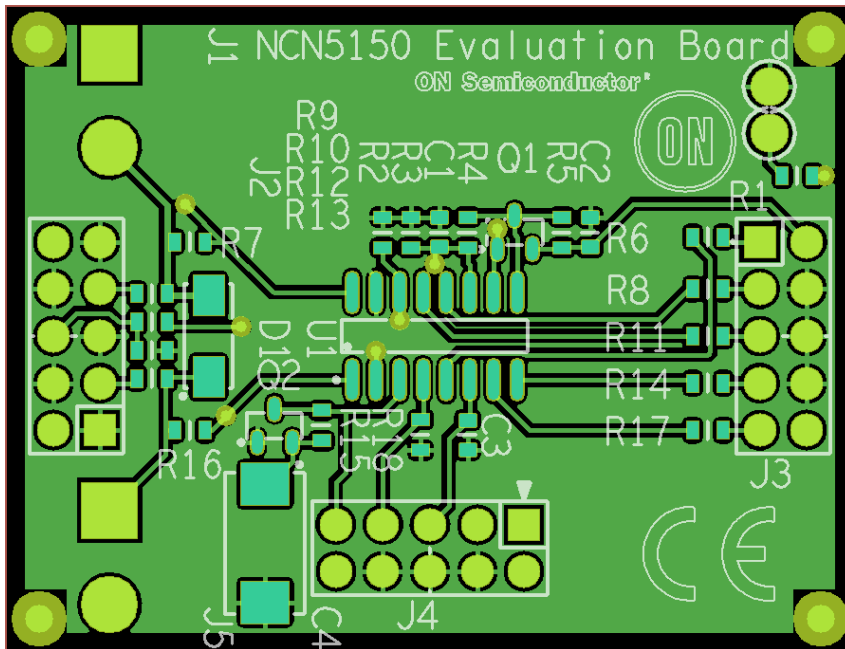

Figure 10. Top Layer Layout (SOIC)

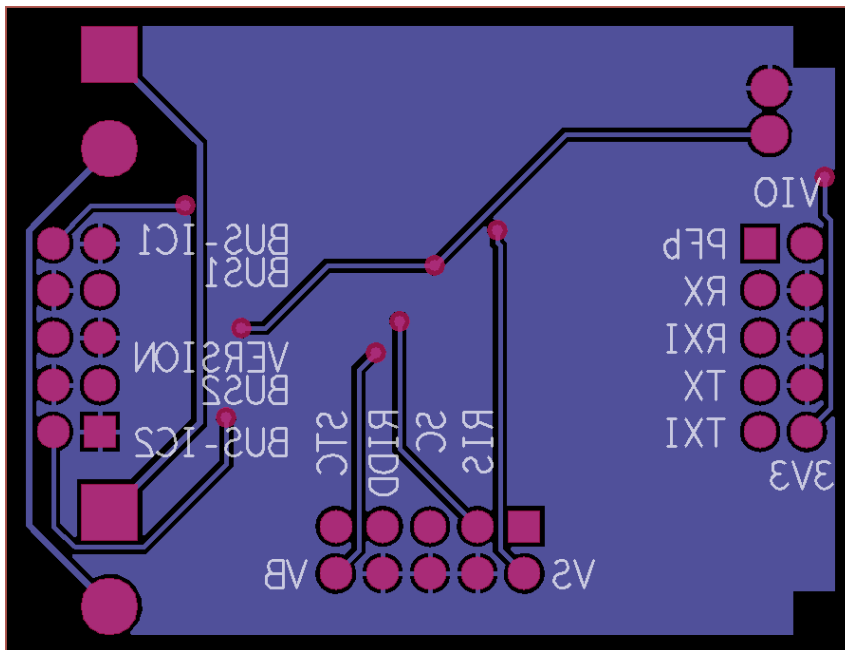



Figure 11. Bottom Layer Layout (SOIC)



**ON Semiconductor** and  are registered trademarks of Semiconductor Components Industries, LLC (SCILLC). SCILLC owns the rights to a number of patents, trademarks, copyrights, trade secrets, and other intellectual property. A listing of SCILLC's product/patent coverage may be accessed at [www.onsemi.com/site/pdf/Patent-Marking.pdf](http://www.onsemi.com/site/pdf/Patent-Marking.pdf). SCILLC reserves the right to make changes without further notice to any products herein. SCILLC makes no warranty, representation or guarantee regarding the suitability of its products for any particular purpose, nor does SCILLC assume any liability arising out of the application or use of any product or circuit, and specifically disclaims any and all liability, including without limitation special, consequential or incidental damages. "Typical" parameters which may be provided in SCILLC data sheets and/or specifications can and do vary in different applications and actual performance may vary over time. All operating parameters, including "Typicals" must be validated for each customer application by customer's technical experts. SCILLC does not convey any license under its patent rights nor the rights of others. SCILLC products are not designed, intended, or authorized for use as components in systems intended for surgical implant into the body, or other applications intended to support or sustain life, or for any other application in which the failure of the SCILLC product could create a situation where personal injury or death may occur. Should Buyer purchase or use SCILLC products for any such unintended or unauthorized application, Buyer shall indemnify and hold SCILLC and its officers, employees, subsidiaries, affiliates, and distributors harmless against all claims, costs, damages, and expenses, and reasonable attorney fees arising out of, directly or indirectly, any claim of personal injury or death associated with such unintended or unauthorized use, even if such claim alleges that SCILLC was negligent regarding the design or manufacture of the part. SCILLC is an Equal Opportunity/Affirmative Action Employer. This literature is subject to all applicable copyright laws and is not for resale in any manner.

## PUBLICATION ORDERING INFORMATION

### LITERATURE FULFILLMENT:

Literature Distribution Center for ON Semiconductor  
P.O. Box 5163, Denver, Colorado 80217 USA  
**Phone:** 303-675-2175 or 800-344-3860 Toll Free USA/Canada  
**Fax:** 303-675-2176 or 800-344-3867 Toll Free USA/Canada  
**Email:** [orderlit@onsemi.com](mailto:orderlit@onsemi.com)

**N. American Technical Support:** 800-282-9855 Toll Free  
USA/Canada  
**Europe, Middle East and Africa Technical Support:**  
Phone: 421 33 790 2910  
**Japan Customer Focus Center**  
Phone: 81-3-5817-1050

**ON Semiconductor Website:** [www.onsemi.com](http://www.onsemi.com)  
**Order Literature:** <http://www.onsemi.com/orderlit>  
For additional information, please contact your local  
Sales Representative