



Chipsmall Limited consists of a professional team with an average of over 10 year of expertise in the distribution of electronic components. Based in Hongkong, we have already established firm and mutual-benefit business relationships with customers from,Europe,America and south Asia,supplying obsolete and hard-to-find components to meet their specific needs.

With the principle of “Quality Parts,Customers Priority,Honest Operation,and Considerate Service”,our business mainly focus on the distribution of electronic components. Line cards we deal with include Microchip,ALPS,ROHM,Xilinx,Pulse,ON,Everlight and Freescale. Main products comprise IC,Modules,Potentiometer,IC Socket,Relay,Connector.Our parts cover such applications as commercial,industrial, and automotives areas.

We are looking forward to setting up business relationship with you and hope to provide you with the best service and solution. Let us make a better world for our industry!



Contact us

Tel: +86-755-8981 8866 Fax: +86-755-8427 6832

Email & Skype: info@chipsmall.com Web: www.chipsmall.com

Address: A1208, Overseas Decoration Building, #122 Zhenhua RD., Futian, Shenzhen, China



NCN6004A

Dual SAM/SIM Interface Integrated Circuit

The NCN6004A is an interface IC dedicated for Secured Access Module reader/writer applications. It allows the management of two external ISO/EMV cards thanks to a simple and flexible microcontroller interface. Several NCN6004A interfaces can share a single data bus, assuming the external MPU provides the right Chip Select signals to identify each IC connected on the bus. A built in accurate protection system guarantees timely and controlled shutdown in the case of external error conditions.

On top of that, the NCN6004A can independently handle the power supply, in the range 2.7 V to 5.0 V input voltage, provided to each external Smart Card. The interface monitors the current flowing into each Smart Card, a flag being set in the case of overload.

Features

- Separated, Built-in DC/DC Converters Supply V_{CC} Power to External Cards
- 100% Compatible with ISO 7816-3, EMV and GIE-CB Standards
- Fully GSM Compliant
- Individually Programmable ISO/EMV Clock Generator
- Built-in Programmable CRD_CLK Stop Function Handles Run or High/Low State
- Programmable CRD_CLK Slopes to Cope with Wide Operating Frequency Range
- Programmable Independent V_{CC} Supply for Each Smart Card
- Support up to 65 mA V_{CC} Supply to Each ISO/EMV Card
- Multiple NCN6004A Parallel Operation on a Shared Bus
- 8 kV/Human Model ESD Protection on Each Interface Pin
- Provides C4/C8 Channels
- Provides 1.8 V, 3.0 V or 5.0 V Card Supply Voltages
- Pb-Free Package is Available*

Typical Applications

- Set Top Box Decoder
- ATM Multi Systems, POS, Handheld Terminals
- Internet E-commerce PC Interface
- Multiple Self Serve Automatic Machines
- Wireless Phone Payment Interface
- Automotive Operating Time Controller

*For additional information on our Pb-Free strategy and soldering details, please download the ON Semiconductor Soldering and Mounting Techniques Reference Manual, SOLDERRM/D.



ON Semiconductor®

<http://onsemi.com>

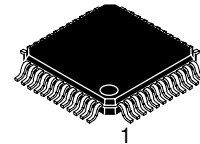

TQFP48
CASE 932F
PLASTIC

MARKING DIAGRAM

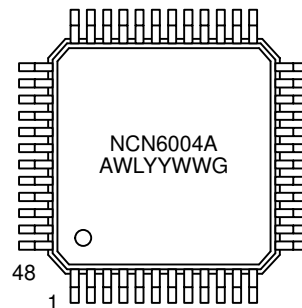

A = Assembly Location
WL = Wafer Lot
YY = Year
WW = Work Week
G = Pb-Free Package

ORDERING INFORMATION

Device	Package	Shipping†
NCN6004AFTBR2	TQFP48	2000/Tape & Reel
NCN6004AFTBR2G	TQFP48 (Pb-Free)	2000/Tape & Reel

†For information on tape and reel specifications, including part orientation and tape sizes, please refer to our Tape and Reel Packaging Specifications Brochure, BRD8011/D.

NCN6004A

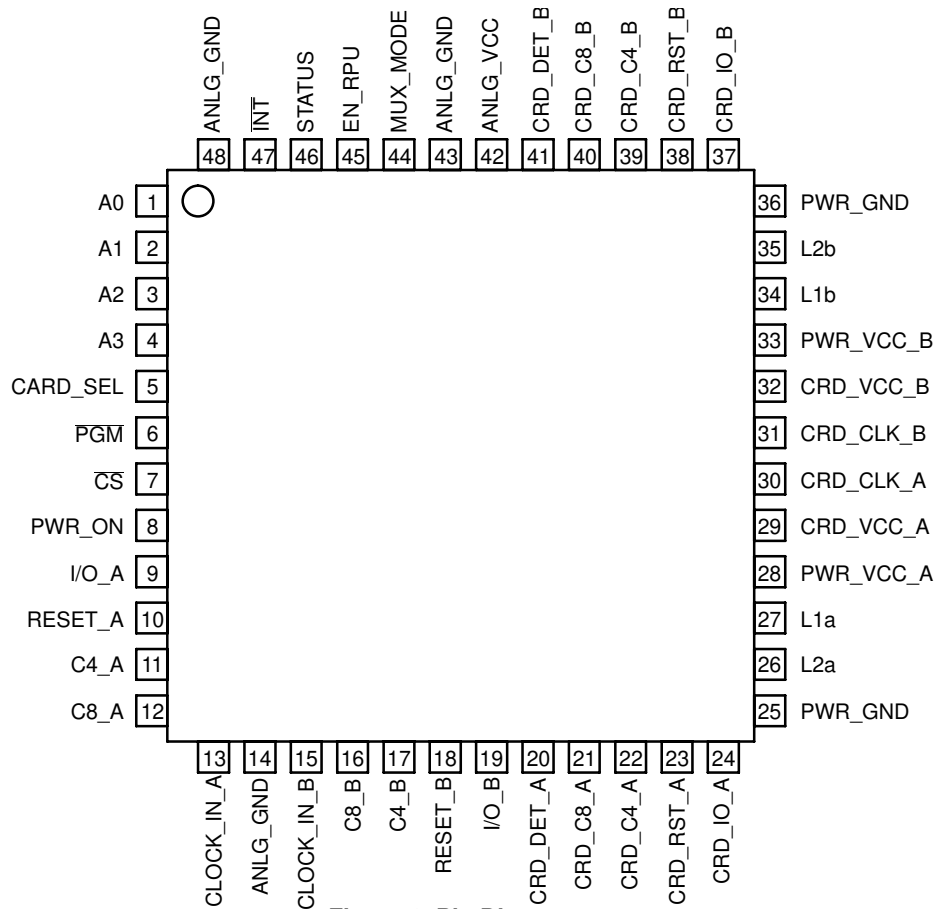

Figure 1. Pin Diagram

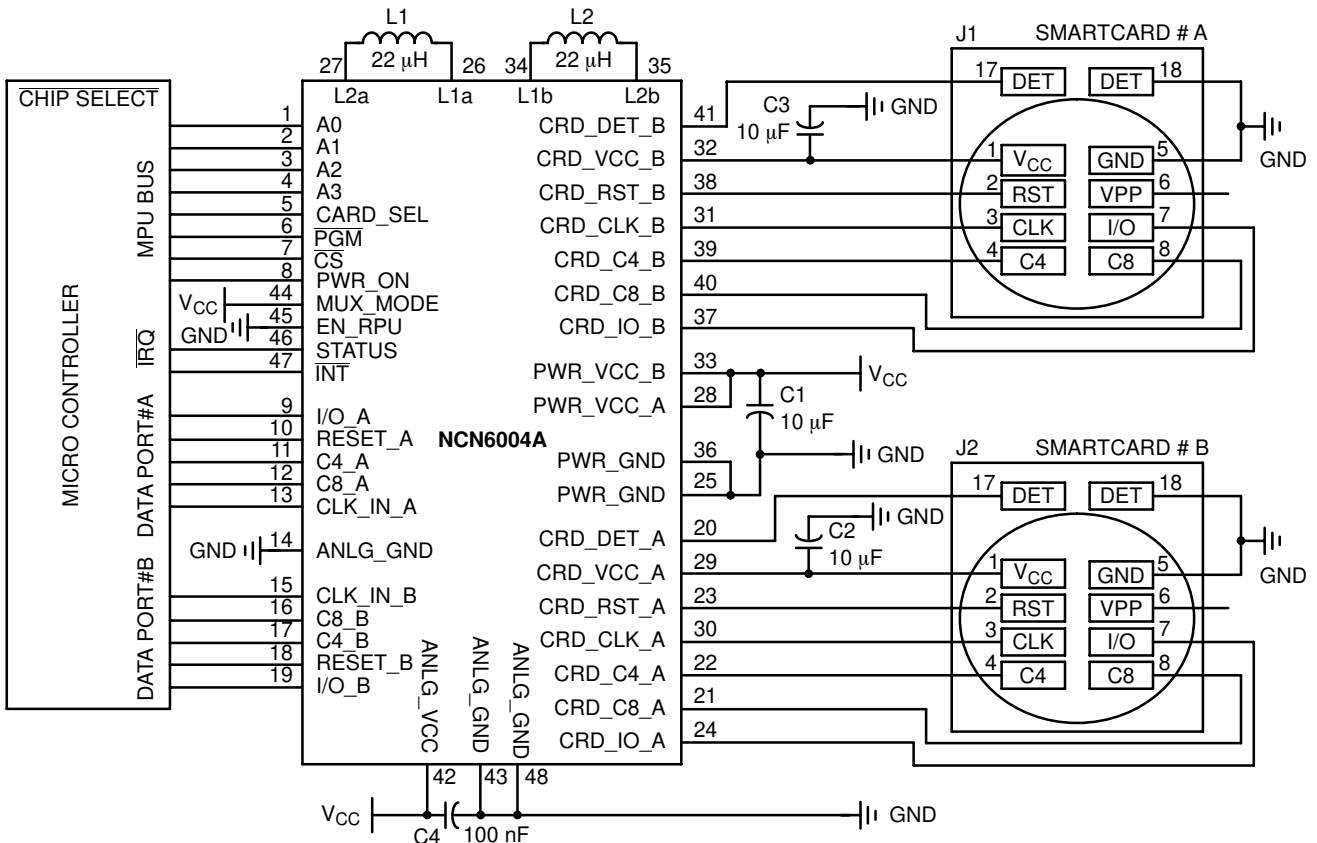

Figure 2. Typical Application

NCN6004A

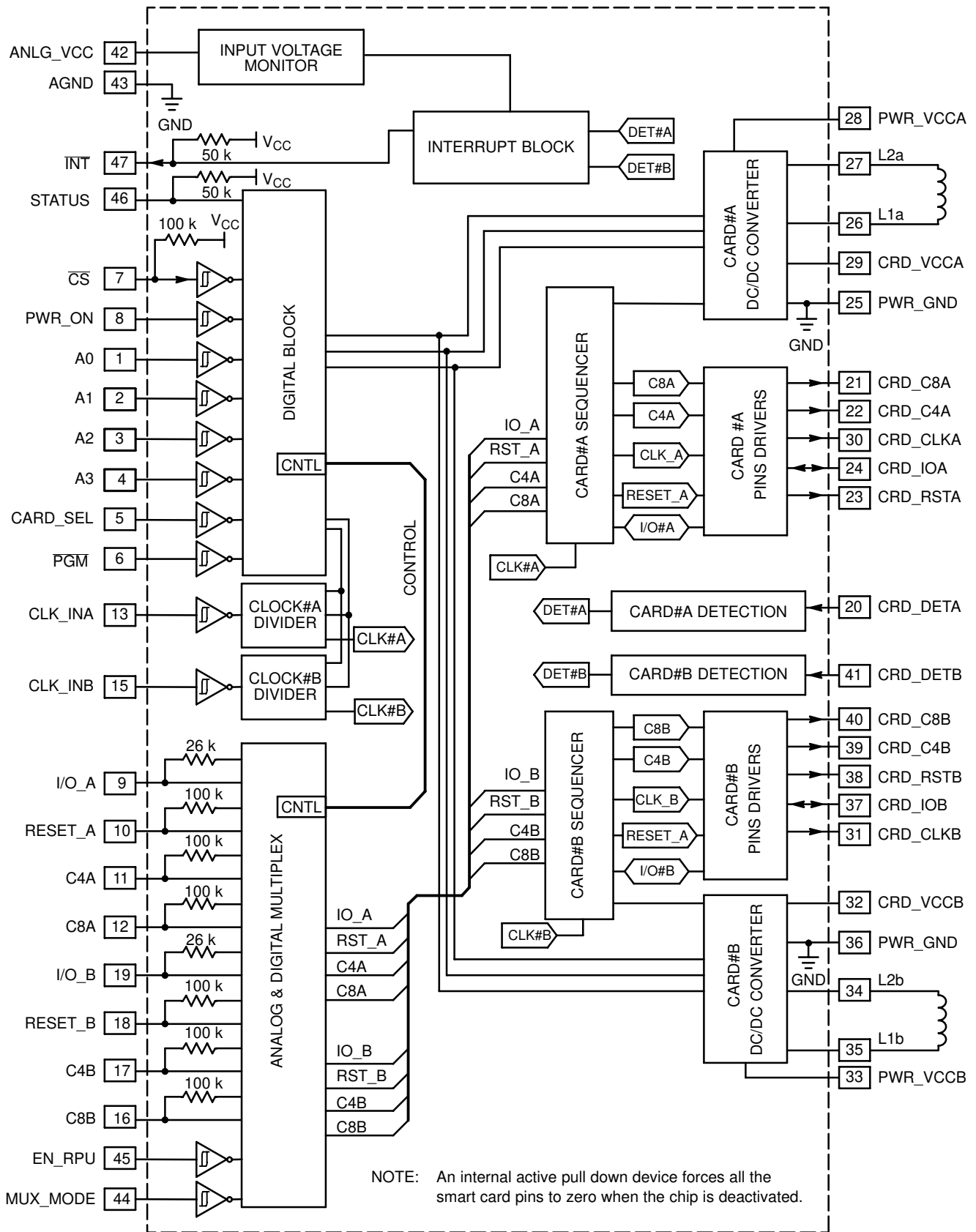

Figure 3. Block Diagram

NCN6004A

PIN DESCRIPTION

Pin	Symbol	Type	Description
1	A0	INPUT	This pin is combined with \overline{CS} , A1, A2, A3, CARD_SEL and \overline{PGM} to program the chip mode of operation, the CRD_VCC voltage value, and to read the data provided by the internal STATUS register (Table 1).
2	A1	INPUT	This pin is combined with \overline{CS} , A0, A2, A3, CARD_SEL and \overline{PGM} to program the chip mode of operation, the CRD_VCC voltage value, and to read the data provided by the internal STATUS register (Table 1).
3	A2	INPUT	This pin is combined with \overline{CS} , A0, A1, A3, CARD_SEL and \overline{PGM} to program the chip mode of operation, the CRD_VCC voltage value, and to read the data provided by the internal STATUS register (Table 1).
4	A3	INPUT	This pin is combined with \overline{CS} , A0, A1, A2, CARD_SEL and \overline{PGM} to program the chip mode of operation, the CRD_VCC voltage value, and to read the data provided by the internal STATUS register (Table 1).
5	CARD_SEL	INPUT	This pin provides logic identification of the Card #A/Card #B external smart card. The logic signal is set up by the external microcontroller. CARD_SEL = High → selection of the Smart Card A connected to pins 20, 21, 22, 23, 24, 29 and 30 (respectively CRD_DET_A, CRD_C8_A, CRD_C4_A, CRD_RST_A, CRD_IO_A, CRD_VCC_A and CRD_CLK_A). CARD_SEL = Low → selection of the Smart Card B connected to pins 41, 39, 40, 31, 38, 37, and 32 (respectively CRD_DET_B, CRD_C4_B, CRD_C8_B, CRD_CLK_B, CRD_RST_B, CRD_IO_B, and CRD_VCC_B).
6	\overline{PGM}	DIGITAL INPUT	This pin is combined with \overline{CS} , A0, A1, A2, A3, and CARD_SEL to program the chip mode of operation and to read the data provided by the internal STATUS register (Figure 4 and Table 1). \overline{PGM} = H → the NCN6004A is under normal operation and all the data with the external card can be exchanged using any of the Smart Card A or Smart Card B Lines \overline{PGM} = Low → the NCN6004A runs the programming mode and related parameters can be re programmed according to a given need. In this case, the related card side logic signals are latched in their previous states and no transaction can occur. The programmed states are latched upon the \overline{PGM} rising slope (Figure 4).
7	\overline{CS}	DIGITAL INPUT	This pin provides the Chip Select Function for the NCN6004A device. \overline{CS} = High → Pins A0, A1, A2, A3, CARD_SEL, \overline{PGM} , PWR_ON, RESET_A, RESET_B, C4_A, C4_B, C8_A, C8_B, I/O_A and I/O_B are disabled, the pre activated CRD_VCC maintains its currently programmed value. \overline{CS} = Low → Pins A0, A1, A2, A3, CARD_SEL, \overline{PGM} , PWR_ON, RESET_A, RESET_B, C4_A, C4_B, C8_A, C8_B, I/O_A and I/O_B are activated, all the functions being available. An internal pull up resistor, connected to V _{CC} , provides a logic bias when the external μ P is in the high impedance state.
8	PWR_ON	DIGITAL INPUT	This pin activates or deactivates the DC/DC converter selected by CARD_SEL upon positive/negative going transient. PWR_ON = Positive going High → DC/DC Activated PWR_ON = Negative going L → DC/DC switched Off, no power is applied to the associated output CRD_VCC pin. Since uncontrolled action could take place during the rise voltage of the related CRD_VCC_x output, care must be observed to avoid a PWR_ON negative going transient during this period of time. To avoid any logical latch up, using a minimum 1.0 ms delay is recommended prior to power down the related DC/DC converter following a power up command (Figure 12).
9	I/O_A	INPUT/OUTPUT	This pin carries the data transmission between an external microcontroller and the external smart card #A. A built-in bi-directional level translator adapts the signal flowing between the card and the MCU. The level translator is enabled when \overline{CS} = Low. Since a dedicated line is used to communicate the data between the MPU and the smart card, the user can activate the two channels simultaneously, assuming the μ P provides a pair of I/O lines. When MUX_MODE = High, this pin provides an access to either card A or B I/O by means of CARD_SEL selection bit. On the other hand, the internal pull up resistor is automatically disconnected when MUX_MODE = High, avoiding a current overload on the I/O line, regardless of the EN_RPU logic level. This pull up resistor is under the EN_RPU control when MUX_MODE = Low.

NCN6004A

PIN DESCRIPTION (continued)

Pin	Symbol	Type	Description
10	RESET_A	INPUT	<p>The signal present on this pin is translated to the RST pin of the external smart card #A. The CS signal must be Low to validate the RESET function, regardless of the selected card. Assuming the μP provides two independent lines to control the RESET pins, the NCN6004A can control two cards simultaneously.</p> <p>When MUX_MODE = High, this pin provides an access to either card A or B Reset by means of CARD_SEL selection bit.</p> <p>The associated pull up resistor is either connected to V_{CC} (EN_RPU = H) or disconnected when EN_RPU = Low.</p>
11	C4_A	INPUT	<p>This pin controls the card #A C4 contact. The signal can be either de-multiplexed, at MPU level, or is multiplexed with C4_B, depending upon the MUX_MODE logic state.</p> <p>When MUX_MODE = High, this pin provides an access to either card A or B C4 channel by means of CARD_SEL selection bit.</p> <p>The associated pull up resistor is either connected to V_{CC} (EN_RPU = H) or disconnected when EN_RPU = Low.</p>
12	C8_A	INPUT	<p>This pin controls the card #A C8 contact. The signal can be either de-multiplexed, at MPU level, or is multiplexed with C8_B, depending upon the MUX_MODE logic state.</p> <p>When MUX_MODE = High, this pin provides an access to either card A or B C8 channel by means of CARD_SEL selection bit.</p> <p>The associated pull up resistor is either connected to V_{CC} (EN_RPU = H) or disconnected when EN_RPU = Low.</p>
13	CLOCK_IN_A	Clock Input, High Impedance	<p>The signal present on this pin comes from either the MCU master clock, or from any signal fulfilling the logic level and frequency specifications. This signal is fed to the internal clock selection circuit prior to be connected to the external smart card #A. Each of the external card can have different division ratio, depending upon the state of the CRD_SEL pin and associated programming bits. The built-in circuit can be programmed to 1/1, 1/2, 1/4 or 1/8 frequency division ratio.</p> <p>This input is valid and routed to either CRD_CLK_A_DIVIDER or CRD_CLK_B_DIVIDER regardless of the MUX_MODE state, depending upon the CLK_D_A/CRD_D_B and CARD_SEL programmed states (Table 1).</p> <p>Although this input supports the signal coming from a crystal oscillator, care must be observed to avoid digital levels outside the specified V_{IH}/V_{IL} range. Similarly, the input clock signal shall have rise and fall times compatible with the operating frequency.</p>
14	ANLG_GND	POWER	<p>This pin is the ground reference for both analog and digital signals and must be connected to the system Ground. Care must be observed to provide a copper PCB layout designed to avoid small signals and power transients sharing the same track. Good high frequency techniques are strongly recommended.</p>
15	CLOCK_IN_B	Clock Input, High Impedance	<p>The signal present on this pin comes from either the MCU master clock, or from any signal fulfilling the logic level and frequency specifications. This signal is fed to the internal clock selection circuit prior to be connected to the external smart card #B. Each of the external card can have different division ratio, depending upon the state of the CRD_SEL pin and associated programming bits. The built-in circuit can be programmed to 1/1, 1/2, 1/4, or 1/8 frequency division ratio.</p> <p>This input is valid and routed to either CRD_CLK_B_DIVIDER or CRD_CLK_A_DIVIDER regardless of the MUX_MODE state, depending upon the CRD_D_B/CRD_D_A and CARD_SEL programmed states (Table 1).</p> <p>Although this input supports the signal coming from a crystal oscillator, care must be observed to avoid digital levels outside the specified V_{IH}/V_{IL} range. Similarly, the input clock signal shall have rise and fall times compatible with the operating frequency.</p>
16	C8_B	INPUT	<p>This pin controls the card #B C8 contact. The signal can be either de-multiplexed, at MPU level, or is multiplexed with C8_A, depending upon the MUX_MODE logic state.</p> <p>When MUX_MODE = High, this pin is internally disable, a pull up resistor is connected to V_{CC} (regardless of the logic state of EN_RPU is), and the access to card B takes place by C8_A associated with CARD_SEL selection bit.</p> <p>The associated pull up resistor is either connected to V_{CC} (EN_RPU = H) or disconnected when EN_RPU = Low.</p>
17	C4_B	INPUT	<p>This pin controls the card #B C4 contact. The signal can be either de-multiplexed, at MPU level, or is multiplexed with C8_A, depending upon the MUX_MODE logic state.</p> <p>When MUX_MODE = High, this pin is internally disable, a pull up resistor is connected to V_{CC}. (regardless of the logic state of EN_RPU), and the access to card B takes place by C4_A associated with CARD_SEL selection bit.</p> <p>The associated pull up resistor is either connected to V_{CC} (EN_RPU = H) or disconnected when EN_RPU = Low.</p>

NCN6004A

PIN DESCRIPTION (continued)

Pin	Symbol	Type	Description
18	RESET_B	INPUT	<p>The signal present on this pin is translated to the RST pin of the external smart card #B. The \overline{CS} signal must be Low to valid the RESET function, regardless of the selected card. Assuming the μP provides two independent lines to control the RESET pins, and MUX_MODE = Low, the NCN6004A can control two cards simultaneously.</p> <p>When MUX_MODE = High, this pin is internally disable, a pull up resistor is connected to V_{CC}. (regardless of the logic state of EN_RPU), and the access to card B takes place by RESET_A associated with CARD_SEL selection bit.</p> <p>The associated pull up resistor is either connected to V_{CC} (EN_RPU = H) or disconnected when EN_RPU = Low.</p>
19	I/O_B	INPUT/OUTPUT	<p>This pin carries the data transmission between an external microcontroller and the external smart card #B.</p> <p>A built-in bi-directional level translator adapts the signal flowing between the card and the MCU. The level translator is enabled when \overline{CS} = Low. The signal present on this pin is latched when \overline{CS} = High. Since a dedicated line is used to communicate the data between the μP and the smart card, (assuming MUX_MODE = Low) the user can activate the two channels simultaneously, assuming the μP provides a pair of I/O lines. When MUX_MODE = High, this pin is internally disable, the pull up resistor is connected to V_{CC}. (regardless of the logic state of EN_RPU), and the access to card B takes place by I/O_A associated with CARD_SEL selection bit.</p>
20	CRD_DET_A	INPUT	<p>This pin senses the signal coming from the external smart card connector to detect the presence of card #A. The polarity of the signal is programmable as Normally Open or Normally Close switch. The logic signal will be activated when the level is either Low or High, with respect to the polarity defined previously. By default, the input is Normally Open. A built-in circuit prevents uncontrolled short pulses to generate an INT signal. The digital filter eliminates pulse width below 50μs (see spec).</p>
21	CRD_C8_A	OUTPUT	<p>This pin controls the card #A C8 contact, according to the ISO7816 specifications. A built-in level shifter is used to adapt the card and the μC, regardless of the power supply voltage of each signals.</p> <p>The signal present at this pin is latched upon either CARD_SEL = L, or \overline{CS} = H or PGM = L, and resume to a transparent mode when card #A is selected and operates in the transfer mode. The pin is hardwired to zero, the bias being provided by the V_{CC} supply, when either the V_{CC} voltage drops below 2.7 V, or during the CRD_VCC_A startup time.</p>
22	CRD_C4_A	OUTPUT	<p>This pin controls the card #A C4 contact, according to the ISO7816 specifications. A built-in level shifter is used to adapt the card and the MCU, regardless of the power supply voltage of each signals.</p> <p>The signal present at this pin is latched upon either CARD_SEL = L, or \overline{CS} = H, or PGM = L, and resume to a transparent mode when card #A is selected and operates in the transfer mode.</p> <p>The pin is hardwired to zero, the bias being provided by the V_{CC} supply, when either the V_{CC} voltage drops below 2.7 V, or during the CRD_VCC_A startup time.</p>
23	CRD_RST_A	OUTPUT	<p>This pin is connected to the external smart card #A to support the RESET signal. A built-in level shifter is used to adapt the card and the MCU, regardless of the power supply voltage of each signals.</p> <p>The signal present at this pin is latched upon either CARD_SEL = Low, or when \overline{CS} or PGM returns to a High, and resume to a transparent mode when card #A is selected. The pin is hardwired to zero, the bias being provided by the V_{CC} supply, when either the V_{CC} voltage drops below 2.7 V, or during the CRD_VCC_A startup time.</p>
24	CRD_IO_A	INPUT/OUTPUT	<p>This pin carries the data serial connection between the external smart card #A and the microcontroller. A built-in bidirectional level shifter is used to adapt the card and the MCU, regardless of the power supply voltage of each signals.</p> <p>This pin is biased by a pull up resistor connected to CRD_VCC_A. When \overline{CS} = High, the CRD_IO_A holds the previous I/O logic state and resume to a normal operation when this pin is reactivated.</p> <p>The pin is hardwired to zero, the bias being provided by the V_{CC} supply, when either the V_{CC} voltage drops below 2.7 V, or during the CRD_VCC_A start-up time.</p>
25	PWR_GND	POWER	<p>This pin carries the power current flow coming from the built in DC/DC converters. It is associated with the external card # A. It must be connected to the system Ground and care must be observed at PCB layout level to avoid the risk of spike voltages on the logic lines.</p>
26	L2_A	POWER	<p>Connects one side of the external DC/DC converter inductor #A (Note 1).</p>
27	L1_A	POWER	<p>Connects one side of the external DC/DC converter inductor #A (Note 1).</p>

1. The external inductors shall preferably have the same values. Depending upon the power absorbed by the load, the inductor can range from 10 μ H to 47 μ H. To achieve the highest yield, the inductor shall have an ESR < 1.0 Ω .

NCN6004A

PIN DESCRIPTION (continued)

Pin	Symbol	Type	Description
28	PWR_VCC_A	POWER	This pin is connected to the positive external power supply. The device sustains any voltage from +2.7 V to +5.5 V. This voltage supplies the NCN6004A internal circuits and is regulated by the internal DC/DC converter to provide the DC voltage to the external card. A high quality capacitor must be connected across pin 28 and PWR_GND, 10 μ F/6.0 V ceramic X7R or X5R type is recommended. Note: The voltage present at pin 28 and 33 must be equal to the voltage present at pin 42.
29	CRD_VCC_A	POWER	This pin provides the power supply to the external smart card #A. The V_{CC} voltage is defined by programming the NCN6004A accordingly. Since the cards have independent DC/DC converter, the output voltage can have any value independently from CARD_B. A high quality, low ESR capacitor is mandatory to achieve the V_{CC} specifications. Using two 4.7 μ F/6.0 V ceramic X7R or X5R capacitors in parallel is recommended.
30	CRD_CLK_A	OUTPUT	This pin is connected to the CLK external smart card #A pin. The signal comes from the built-in frequency divider dedicated to the #A card. The clock is selected and controlled by setting the logic inputs according to Table 1. The slope of the output clock can be selected between one of the two programmable mode: SLOW or FAST (Table 8). The pin is hardwired to zero, the bias being provided by the V_{CC} supply, when either the V_{CC} voltage drops below 2.7 V, or during the CRD_VCC_A startup time.
31	CRD_CLK_B	OUTPUT	This pin is connected to the CLK external smart card #B pin. The signal comes from the built-in frequency divider dedicated to the #B card. The clock is selected and controlled by setting the logic inputs according to Table 1. The slope of the output clock can be selected between one of the two programmable mode: SLOW or FAST (Table 8). The pin is hardwired to zero, the bias being provided by the V_{CC} supply, when either the V_{CC} voltage drops below 2.7 V, or during the CRD_VCC_B startup time.
32	CRD_VCC_B	POWER	This pin provides the power supply to the external smart card #B. The V_{CC} voltage is defined by programming the NCN6004A accordingly. Since the cards have independent DC/DC converter, the output voltage can have any value independently from CARD_A. A high quality, low ESR capacitor is mandatory to achieve the V_{CC} specifications. Using two 4.7 μ F/6.0 V ceramic X7R or X5R capacitors in parallel is recommended.
33	PWR_VCC_B	POWER	This pin is connected to the positive external power supply. The device sustains any voltage from +2.7 V to +6.0 V. This voltage supplies the NCN6004A internal circuits and is regulated by the internal DC/DC converter to provide the DC voltage to the external card. A high quality capacitor must be connected across pin 33 and PWR_GND, 10 μ F/6.0 V ceramic X7R type is recommended. Note: The voltage present on pin 28 and 33 must be equal to the voltage present on pin 42
34	L2b	POWER	Connects one side of the external DC/DC converter inductor #B (Note 1).
35	L1b	POWER	Connects one side of the external DC/DC converter inductor #B (Note 1).
36	PWR_GND	POWER	This pin carries the power current flow coming from the built in DC/DC converters. It is associated with the external card # B. It must be connected to the system Ground and care must be observed at PCB layout level to avoid the risk of spike voltages on the logic lines.
37	CRD_IO_B	INPUT/OUTPUT	This pin carries the data serial connection between the external smart card #B and the microcontroller. A built-in bi-directional level shifter is used to adapt the card and the MCU, regardless of the power supply voltage of each signals. This pin is biased by a pull up resistor connected to CRD_VCC_A. When \overline{CS} = High, the CRD_IO_A holds the previous I/O logic state and resume to a normal operation when this pin is reactivated. The pin is hardwired to zero, the bias being provided by the V_{CC} supply, when either the V_{CC} voltage drops below 2.7 V, or during the CRD_VCC_B startup time.
38	CRD_RST_B	OUTPUT	This pin is connected to the external smart card #B to support the RESET signal. A built-in level shifter is used to adapt the card and the MCU, regardless of the power supply voltage of each signals. The signal present at this pin is latched upon either CARD_SEL or \overline{CS} or \overline{PGM} positive going transient and resume to a transparent mode when card #B is selected. The pin is hardwired to zero, the bias being provided by the V_{CC} supply, when either the V_{CC} voltage drops below 2.7 V, or during the CRD_VCC_B startup time.

1. The external inductors shall preferably have the same values. Depending upon the power absorbed by the load, the inductor can range from 10 μ H to 47 μ H. To achieve the highest yield, the inductor shall have an ESR < 1.0 Ω .

NCN6004A

PIN DESCRIPTION (continued)

Pin	Symbol	Type	Description
39	CRD_C4_B	OUTPUT	This pin controls the card #B C4 contact, according to the ISO specification. A built-in level shifter is used to adapt the card and the MCU, regardless of the power supply voltage of each signals. The signal present at this pin is latched upon either CARD_SEL or CS or PGM positive going transient and resume to a transparent mode when card #B is selected. The pin is hardwired to zero, the bias being provided by the V _{CC} supply, when either the V _{CC} voltage drops below 2.7 V, or during the CRD_VCC_B startup time.
40	CRD_C8_B	OUTPUT	This pin controls the card #B C8 contact, according to the ISO specification. A built-in level shifter is used to adapt the card and the MCU, regardless of the power supply voltage of each signals. The signal present at this pin is latched upon either CARD_SEL or CS or PGM positive going transient and resume to a transparent mode when card #B is selected. The pin is hardwired to zero, the bias being provided by the V _{CC} supply, when either the V _{CC} voltage drops below 2.7 V, or during the CRD_VCC_B startup time.
41	CRD_DET_B	INPUT	This pin senses the signal coming from the external smart card connector to detect the presence of card #B. The polarity of the signal is programmable as Normally Open or Normally Close switch. The logic signal will be activated when the level is either Low or High, with respect to the polarity defined previously. By default, the input is Normally Open. A built-in circuit prevents uncontrolled short pulses to generate an INT signal. The digital filter eliminates pulse width below 50 μs.
42	ANLG_VCC	POWER	This pin is connected to the positive external power supply. The device sustains any voltage from +2.7 V to +5.5 V. This voltage supplies the NCN6004A internal Analog and Logic circuits. A high quality capacitor must be connected across this pin and ANLG_GND, 10 μF/6 V is recommended. A set of extra pins (28 and 33) are provided to connect the power supply to the internal DC/DC converter. Note: The voltage present at pin 28 and 33 must be equal to the voltage present at pin 42
43	ANLG_GND	GROUND	This pin is the ground reference for both analog and digital signals and must be connected to the system Ground. Care must be observed to provide a copper PCB layout designed to avoid small signals and power transients sharing the same track. Good high frequency techniques are strongly recommended.
44	MUX_MODE	INPUT	This pin selects the mode of operation of the card signals from the MPU side. When MUX_MODE = Low, all the card signals are fully de-multiplexed and data transfers can take place with both cards simultaneously. On top of that, both cards can be accessed during the programming sequence, assuming the external microcontroller is capable to run multi tasks software. When MUX_MODE = High, all the card signals are multiplexed and the communications with the cards shall take place in a sequential mode. The card is selected by setting CARD_SEL high or Low. The internal logic will disable the CARD_B inputs and use CARD_SEL inputs as a single channel to controls both output smart cards sequentially when MUX_MODE = H. Moreover, when MUX_MODE = High, all the B channel μP dedicated pins, except CLOCK_IN_B, pin 15, are forced to a high level by means of internal pull up resistors. It is not necessary to connect these pins (16, 17, 18 and 19) to an external bias voltage, but it is mandatory to avoid any connections to ground. On the other hand, in this case the internal pull up resistor connected across I/O_A, pin 9 and V _{CC} is automatically disconnected to avoid a current overload on the I/O line.
45	EN_RPU	INPUT	This pin provides a logic input to valid or not the internal pullup resistors connected across each I/O, RESET, C4 and C8 lines and ANLG_VCC. When EN_RPU = High, the pull up resistors are connected When EN_RPU = Low, the pull up resistors are disconnected and it is up to the designer to set up the external resistor to cope with the ISO/EMV specifications. The logic signal must be set up prior to apply the ANLG_VCC supply. Once the logic mode has been acknowledged by the internal Power On reset, it cannot be changed until a new startup sequence is launched.
46	STATUS	OUTPUT	This pin provides a logic state related to the card [A or B] insertion, the VCC_OK, the CRD_VCC value and the current overflow powered to either card [A or B]. The internal register can be read when PGM = High. The logic level is forced to High when the input voltage drops below the V _{bat} min (2.0 V), thus reducing the stand by current, assuming the STATUS pin is not pulled down externally. The associated pullup resistor is either connected to V _{CC} (EN_RPU = H) or disconnected when EN_RPU = Low.

NCN6004A

PIN DESCRIPTION (continued)

Pin	Symbol	Type	Description
47	INT	OUTPUT	<p>This pin is activated LOW when a card has been inserted and detected in either of the external ports. The signal is reset by either a positive going transition on pin \overline{CS}, or by a High level on pin PWR_ON combined with $\overline{CS} = \text{Low}$.</p> <p>Similarly, an interrupt is generated when either one of the CRD_VCC output is overloaded. On the other hand, the pin is forced to a logic High when the input voltage V_{CC} drops below 2.0 V min.</p> <p>The associated pull up resistor is either connected to V_{CC} (EN_RPU = H) or disconnected when EN_RPU = Low.</p>
48	ANLG_GND	GROUND	<p>This pin is the ground reference for both analog and digital signals and must be connected to the system Ground. Care must be observed to provide a copper PCB layout designed to avoid small signals and power transients sharing the same track. Good high frequency techniques are strongly recommended.</p>

MAXIMUM RATINGS (Note 2)

Rating	Symbol	Value	Unit
Power Supply Input Supply Voltage	V_{CC}	6	V
V_{in}	Digital Input Pins	$-0.5 \text{ V} < V_{in} < V_{CC} + 0.5 \text{ V}$, but $< 6.0 \text{ V}$	V
Power Supply Input Current	$I_{V_{CC}}$	500	mA
Digital Input Pins	V_{in} I_{in}	$-0.5 < V_{CC} \text{ or } V_{CC} < 5.5$ ± 5	V mA
Digital Output Pins	V_{out} I_{out}	$-0.5 < V_{CC} \text{ or } V_{CC} < 5.5$ ± 10	V mA
Card Interface Pins	V_{card} I_{card}	$-0.5 \text{ V} < V_{card} < \text{CRD_VCC} + 0.5 \text{ V}$ 15 mA (internally limited)	V mA
ESD Capability, Human Body Model (Note 3) Standard Pins Card Interface Pins (Card A or B)	V_{ESD}	2 8	kV kV
TQFP48 Power Dissipation @ $T_{ab} = +85^\circ\text{C}$ Thermal Resistance Junction-to-Air	P_D $R_{J\theta A}$	800 50	mW $^\circ\text{C/W}$
Operating Ambient Temperature Range	T_A	-40 to +85	$^\circ\text{C}$
Operating Junction Temperature Range	T_J	-40 to +125	$^\circ\text{C}$
Maximum Junction Temperature (Note 4)	T_{Jmax}	+150	$^\circ\text{C}$
Storage Temperature Range	T_{ag}	-65 to +150	$^\circ\text{C}$

Stresses exceeding Maximum Ratings may damage the device. Maximum Ratings are stress ratings only. Functional operation above the Recommended Operating Conditions is not implied. Extended exposure to stresses above the Recommended Operating Conditions may affect device reliability.

2. Maximum Electrical Ratings are defined as those values beyond which damage(s) to the device may occur at $T_A = +25^\circ\text{C}$.

3. Human Body Model, R = 1500 Ω , C = 100 pF.

4. Absolute Maximum Rating beyond which damage(s) to the device may occur.

NCN6004A

POWER SUPPLY SECTION General test conditions, unless otherwise specified: Operating temperature: $-25^{\circ}\text{C} < T_A < +85^{\circ}\text{C}$,
 $V_{CC} = +3.0\text{ V}$, $\text{CRD_VCC_A} = \text{CRD_VCC_B} = +5.0\text{ V}$.

Rating	Symbol	Pin	Min	Typ	Max	Unit
$I_{out} = 2 \times 65\text{ mA}$ (both external cards running simultaneously) @ $3.0\text{ V} < V_{CC} < 5.5\text{ V}$	CRD_VCC	29, 32	4.6	-	5.4	V
$I_{out} = 2 \times 55\text{ mA}$ per pin (both external cards running) V_{out} defined @ $\text{CRD_VCC} = 3.0\text{ V}$ @ $3.0\text{ V} < V_{CC} < 5.5\text{ V}$	CRD_VCC	29, 32	2.7	-	3.3	V
$I_{out} = 2 \times 35\text{ mA}$ per pin (both external cards running) V_{out} defined @ $\text{CRD_VCC} = 1.80\text{ V}$ @ $3.0\text{ V} < V_{CC} < 5.5\text{ V}$	CRD_VCC	29, 32	1.65	-	1.95	V
Output Card Supply Voltage Ripple (per CRD_VCC outputs) @ : $L_{out} = 22\text{ }\mu\text{H}$, $L_{ESR} < 2.0\text{ }\Omega$, $C_{out} = 10\text{ }\mu\text{F}$ per CRD_VCC (Note 5) $I_{out} = 35\text{ mA}$, $V_{out} = 1.80\text{ V}$ $I_{out} = 55\text{ mA}$, $V_{out} = 3.0\text{ V}$ $I_{out} = 65\text{ mA}$, $V_{out} = 5.0\text{ V}$	VORA VORB	29 32	- - -	- - -	50 50 50	mV
DC/DC Dynamic Inductor Peak Current @ $V_{bat} = 5.0\text{ V}$, $L_{out} = 22\text{ }\mu\text{H}$, $C_{out} = 10\text{ }\mu\text{F}$ CRD_VCC = 1.8 V CRD_VCC = 3.0 V CRD_VCC = 5.0 V	I _{ccov}	29, 32	- - -	200 280 430	- - -	mA
Standby Supply Current Conditions (Note 5): ANLG_VCC = PWR_VCC = 3.0 V PWR_ON = H, STATUS = H, CS = H Card A and Card B CLOCK_IN = H, I/O = H, RESET = H All Logic Inputs = H, Temperature range = 0°C to $+50^{\circ}\text{C}$ ANLG_VCC = PWR_VCC = 5.0 V Temperature range -25°C to $+85^{\circ}\text{C}$ All other test conditions identical ANLG_VCC = PWR_VCC = 1.8 V Temperature range -25°C to $+50^{\circ}\text{C}$ All other test conditions identical Note: This parameter is guaranteed by design, not production tested.	I _{DD}	42, 28, 33	- - -	- - -	20 - - 50 - - 5.0 -	μA
Operating Supply Current ANLG_VCC = PWR_VCC = 5.5 V @ CRD_VCC_A/B = 5.0 V @ CRD_VCC_A/B = 3.0 V @ CRD_VCC_A/B = 1.85 V ANLG_VCC = PWR_VCC = 3.3 V @ CRD_VCC_A/B = 5.0 V @ CRD_VCC_A/B = 3.0 V @ CRD_VCC_A/B = 1.85 V PWR_ON = H, CS = H, CLK_A = CLK_B = Low, all card pins unloaded	I _{DDop}	42, 28, 33	- - -	0.7 0.7 0.7 0.2 0.2 0.2	- - -	mA
V_{bat} Under Voltage Detection Positive Going Slope V_{bat} Under Voltage Detection Negative Going Slope V_{bat} Under Voltage Detection Hysteresis Note: The voltage present in pins 28 and 33 must be equal to or lower than the voltage present in pin 42.	V_{batLH} V_{batLL} V_{batHY}	42	2.1 2.0 -	- - 100	2.7 2.6 -	V V mV
Output Continuous Current Card A or Card B (both cards can be operating simultaneously) @ $3.0 < V_{CC} < 5.5\text{ V}$ Output Voltage = 1.85 V Output Voltage = 3.0 V Output Voltage = 5.0 V	I _{ccp}	31, 42	35 55 65	- - -	- - -	mA
Output Over Current Limit (A or B) $V_{bat} = 3.3\text{ V}$, CRD_VCC = 1.8 V, 3.0 V or 5.0 V $V_{bat} = 5.0\text{ V}$, CRD_VCC = 1.8 V, 3.0 V or 5.0 V	I _{ccov}	31, 42	- -	100 150	- -	mA
Output Over Current Time Out Per Card	I _{tdoff}	31, 42	- -	4.0	- -	ms
Output Card Supply Turn On Time @ $L_{out} = 22\text{ }\mu\text{F}$, $C_{out} = 10\text{ }\mu\text{F}$ Ceramic. $V_{CC} = 2.7\text{ V}$, CRD_VCC = 5.0 V (A or B)	V _{CCTON}	31, 42	- -	- -	500	μs

5. Assuming ANLG_VCC and PWR_VCC pins are connected to the same power supply.

NCN6004A

POWER SUPPLY SECTION General test conditions, unless otherwise specified: Operating temperature: $-25^{\circ}\text{C} < T_A < +85^{\circ}\text{C}$, $V_{CC} = +3.0\text{ V}$, $\text{CRD_VCC_A} = \text{CRD_VCC_B} = +5.0\text{ V}$. (continued)

Rating	Symbol	Pin	Min	Typ	Max	Unit
Output Card Supply Shut Off Time @ $C_{out} = 10\ \mu\text{F}$, ceramic. $V_{CC} = 2.7\text{ V}$, $\text{CRD_VCC} = 5.0\text{ V}$, $V_{CCOFF} < 0.4\text{ V}$ (A or B)	V_{CCOFF}	31, 42		100	250	μs
DC/DC Converter Operating Frequency (A or B)	F_{SW}	31, 42		600		kHz

5. Assuming ANLG_VCC and PWR_VCC pins are connected to the same power supply.

DIGITAL INPUT/OUTPUT SECTION

$2.70 < V_{CC} < 5.50\text{ V}$, Normal Operating Mode (-25°C to $+85^{\circ}\text{C}$ ambient temperature, unless otherwise noted)

Rating	Symbol	Pin	Min	Typ	Max	Unit
A0, A1, A2, A3, CARD_SEL, PWR_ON, PGM, CS, MUX_MODE, EN_RPU, RESET_A, RESET_B, C4_A, C8_A, C4_B, C8_B High Level Input Voltage Low Level Input Voltage Input Capacitance	V_{IH} V_{IL} C_{in}	1, 2, 3, 4, 5, 6, 7, 8, 44, 45, 10, 18, 11, 12, 16, 17	$0.7 * V_{bat}$		V_{bat} $0.3 * V_{bat}$ 10	V V pF
STATUS, INT Output High Voltage @ $I_{OH} = -10\ \mu\text{A}$ Output Low Voltage @ $I_{OH} = 200\ \mu\text{A}$	V_{OH} V_{OL}	46, 47	$V_{bat} - 1.0\text{ V}$		0.40	V
STATUS, INT Output Rise Time @ $C_{out} = 30\text{ pF}$ Output Fall Time @ $C_{out} = 30\text{ pF}$	trsta, trint tfsta, tfint				5 100	μs ns
CLOCK_A Asynchronous Input Clock @ DC = 50% \pm 1%	F_{CLKINA}	13			40	MHz
CLOCK_B Asynchronous Input Clock @ DC = 50% \pm 1%	F_{CLKINB}	15			40	MHz
I/O_A, I/O_B, both directions @ $C_{out} = 30\text{ pF}$ I/O Rise Time I/O Fall Time	t_{rioA} , t_{rioB} t_{rioA} , t_{rioB}	9, 19			0.8 0.8	μs
STATUS Pull Up Resistance	R_{STA}	46	35	50		k Ω
INT Pull Up Resistance	R_{INT}	47	35	50		k Ω
I/O_A Pull Up Resistance	R_{IOA}	9	14	20	35	k Ω
I/O_B Pull Up Resistance	R_{IOB}	19	14	20	35	k Ω
RESET_A Pull Up Resistance	R_{RSTA}	10	60	100		k Ω
RESET_B Pull Up Resistance	R_{RSTB}	18	60	100		k Ω
C4_A Pull Up Resistance	R_{C4A}	11	60	100		k Ω
C8_A Pull Up Resistance	R_{C8A}	12	60	100		k Ω
C4_B Pull Up Resistance	R_{C4B}	17	60	100		k Ω
C8_B Pull Up Resistance	R_{C8B}	16	60	100		k Ω
CS Pull Up Resistance	R_{CS}	7	60	100		k Ω
CRD_DET_A and CRD_DET_B Pull Up Resistance	R_{DETA} R_{DETB}	20 41		500 500		k Ω k Ω

NCN6004A

CARD INTERFACE SECTION @ $2.70 < V_{CC} < 5.50$ V, Normal Operating Mode (-25°C to $+85^{\circ}\text{C}$ ambient temperature, unless otherwise noted) $\text{CRD_VCC_A} = \text{CRD_VCC_B} = 1.8$ V or 3.0 V or 5.0 V

Rating	Symbol	Pin	Min	Typ	Max	Unit
CRD_RST_A, CRD_RST_B Output Voltage Output RST High Level @ $I_{rst} = -200 \mu\text{A}$ Output RST Low Level @ $I_{rst} = 200 \mu\text{A}$	V_{OH} V_{OL}	23, 38 23, 38	$\text{CRD_VCC} - 0.5$ 0		CRD_VCC 0.4	V V
CRD_RST_A, CRD_RST_B Rise and Fall time RST Rise Time @ $C_{out} = 30$ pF RST Fall Time @ $C_{out} = 30$ pF	t_{rrst} t_{frst}	23, 38 23, 38			100 100	ns ns
CRD_CLK_A, CRD_CLK_B Output Clock Output Operating Clock Card A and Card B Output Operating Clock DC, Card A and Card B (Input DC = 50%, $\pm 1\%$) Note: This parameter is guaranteed by design, functionality 100% tested at production. Output Operating Clock Rise Time SLOW Mode Card A and Card B Output Operating Clock Fall Time SLOW Mode Card A and Card B Output Operating Clock Rise Time FAST Mode Card A and Card B Output Operating Clock Fall Time FAST Mode Card A and Card B Output Clock High Level, Card A and Card B, @ $I_{clk} = -200 \mu\text{A}$ Output Clock Low Level, Card A and Card B, @ $I_{clk} = 200 \mu\text{A}$	F_{clkA}, F_{clkB} V_{OH} V_{OL}	30, 31	45		20 55	MHz %
CRD_IO_A, CRD_IO_B Data Transfer Data Transfer Frequency, Card A and Card B Data Rise Time, Card A and Card B, @ $C_{out} = 30$ pF Data Fall Time, Card A and Card B, @ $C_{out} = 30$ pF Data Output High Level, Card A and Card B @ $I_{crd_io} = -20 \mu\text{A}$ Data Output Low Level, Card A and Card B @ $I_{crd_io} = 20 \mu\text{A}$	F_{IOA}, F_{IOB} t_{rIOA}, t_{rIOB} t_{fIOA}, t_{fIOB} V_{OH} V_{OL}	24, 37	$\text{CRD_VCC} - 0.5$ 0	400	0.8 0.8 CRD_VCC 0.4	kHz μs μs V V
CRD_IO_A and CRD_IO_B Output Voltages $I/O_A = I/O_B = 0, I_{OL} = 500 \mu\text{A}$	V_{OL}	24, 37			0.40	V
CRD_C4_A, CRD_C4_B Output Voltages Output C4 High Level @ $I_{rst} = -200 \mu\text{A}$ Output C4 Low Level @ $I_{rst} = 200 \mu\text{A}$ CRD_C4_A, CRD_C4_B Rise and Fall time C4 Rise Time @ $C_{out} = 30$ pF C4 Fall Time @ $C_{out} = 30$ pF	V_{OH} V_{OL} t_{rc4} t_{fc4}	22, 39	$\text{CRD_VCC} - 0.5$ 0		CRD_VCC 0.4	V V ns ns
CRD_C8_A, CRD_C8_B Output Voltages Output C4 High Level @ $I_{rst} = -200 \mu\text{A}$ Output C4 Low Level @ $I_{rst} = 200 \mu\text{A}$ CRD_C8_A, CRD_C8_B Rise and Fall Time C8 Rise Time @ $C_{out} = 30$ pF C8 RST Fall Time @ $C_{out} = 30$ pF	V_{OH} V_{OL} t_{rc8} t_{fc8}	21, 40	$\text{CRD_VCC} - 0.5$ 0		CRD_VCC 0.4	V V ns ns
Pull Up resistance, $\overline{CS} = \text{Low}, \text{PWR_ON} = \text{High}$ CRD_IO_A CRD_IO_B	R_{OLA} R_{OLB}	24 37	14 14	20 20	35 35	k Ω
Card Detection Bias Pull Up Current, Card A or Card B CRD_DET_A, CRD_DET_B	I_{DETA} I_{DETB}	20 41		15 15		μA
Card Insertion/Extraction Negative Going Input Low Voltage	V_{ILDETA} V_{ILDETB}	20 41	0 0		$0.30 * V_{bat}$ $0.30 * V_{bat}$	V
Card Detection Insertion/Extraction Digital Filtering Delay CRD_DET_A CRD_DET_B	t_{dcina} t_{dcinb}	20 41		50 50		μs
CARD_A or CARD_B short circuit current: CRD_IO, CRD_RST, CRD_C4, CRD_C8 CRD_CLK (According to I \overline{S} O and EMV specifications)	I_{short} $I_{shortclk}$				15 70	mA

NCN6004A

DIGITAL DYNAMIC SECTION NORMAL OPERATING MODE

Rating	Symbol	Pin	Min	Typ	Max	Unit
Card Signal Sequence Interval, CRD_VCC_A and CRD_VCC_B: CRD_IO_A, CRD_RST_A, CRD_CLK_A, CRD_C4_A, CRD_C8_A CRD_IO_B, CRD_RST_B, CRD_CLK_B, CRD_C4_B, CRD_C8_B	t_{dseq}	24, 23, 30, 37, 38, 31		0.5 0.5	2 2	μ s
Internal RESET Delay	t_{dreset}			1.0		μ s
Internal STATUS Delay Time	t_{dready}	46		1.0		μ s
PWR_ON Low State Pulse Width (Figure 11), Assuming CRD_VCC reservoir capacitor = 10 μ F.	t_{pwrlo}	8	5			μ s
PWR_ON High State Pulse Width (Figure 11)	t_{pwrset}	8	200			ns
PWR_ON Preset Delay (Figure 11)	t_{pwrpre}	5, 7, 8	300			ns
PWR_ON Programming Hold Time (Figure 11)	$t_{pwrhold}$	5, 7, 8	100			ns
PWR_ON to CARD_SEL Change Delay Time (Figure 12)	$t_{cseldly}$	5, 6, 8	100			ns
$\overline{\text{PGM}}$ to PWR_ON Delay Time (Figure 12)	t_{pgmdly}	5, 6, 8	300			ns
PWR_ON internal Set/Reset Pulses Width (Figure 12)	t_{pwrp}	8		20		ns

DIGITAL DYNAMIC SECTION PROGRAMMING MODE

Rating	Symbol	Pin	Min	Typ	Max	Unit
Data Set-up Time, Time Reference = $\overline{\text{PGM}}$, A0, A1, A2, A3, CARD_SEL, and $\overline{\text{CS}}$.	t_{smod}	8, 46, 1, 2, 3, 4, 5, 6	100			ns
Data Signal Rise and Fall Time	t_{smodtr}				50	ns
Data Hold Time, Time Reference = $\overline{\text{PGM}}$, A0, A1, A2, A3, CARD_SEL, and $\overline{\text{CS}}$.	t_{smod} t_{smodtr}	8, 46, 1, 2, 3, 4, 5, 6	100		50	ns ns
Chip Select $\overline{\text{CS}}$ Low State Pulse Width $\overline{\text{CS}}$ Signal Rise and Fall Time	t_{wcs} t_{rfcs}	7	300		50	ns ns

NCN6004A

PROGRAMMING AND STATUS FUNCTIONS

The NCN6004A includes a programming interface and a status interface. Figure 4 illustrates the sequence one must follow to enter and exit the programming mode. Table 1 and Table 2 provide the logical functions associated with the

input and output signals. The parameters are latched upon the rising edge of the PGM signal, the \overline{CS} pin being held low. Any number of programming sequences can be performed while the \overline{CS} pin is Low, but the minimum timings must be observed.

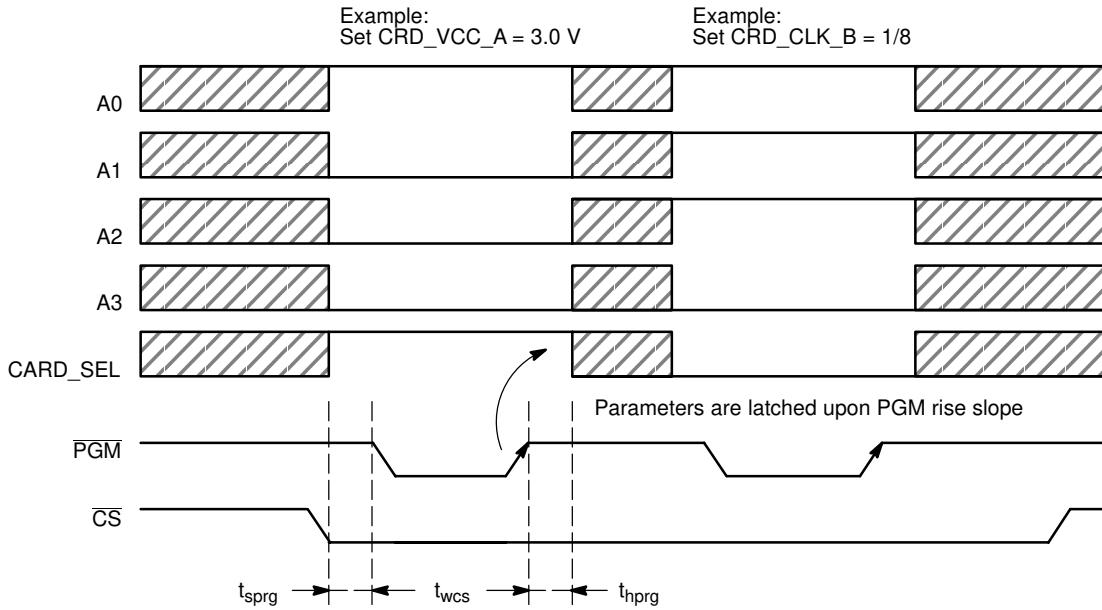

Figure 4. Programming Sequence

On the other hand, since the programming data are latched upon the rising edge of the PGM signal, the most up to date selected card (using $CARD_SEL = H$ or L) is used to activate the associated card. Consequently, when both cards must be updated with the same programmed content, a dual PGM sequence must be carried out, changing the $CARD_SEL$ signal during the High level state of the PGM pin.

Although selecting a card is possible during the same Chip Select sequence (as depicted here above), the user must

make sure that no data will be present to a card not ready for such a function. As a matter of fact, all the card signals are routed to the selected card immediately after a $CARD_SEL$ change, the NCN6004A taking no further logic control prior to activate the swap. To avoid any risk, one can run a sequence with the selected card, return \overline{CS} to High, change the $CARD_SEL$ according to the expected card selection, and pull \overline{CS} to Low to activate the selected card.

Table 1. Programming and Reading Basic Functions

Pin	Name	Select #A #B	Select V_{CC} ON/OFF	Program CLOCK_IN	Poll Card Status #A or #B	Poll I_{CC} Overload #A or #B	ANLG_VCC Input Voltage OK
7	\overline{CS}	0	0	0	0	0	0
46	STATUS	-	-	-	READ	READ	READ
1	A0	0/1	0/1	0/1	1	0	0
2	A1	0/1	0/1	0/1	1	1	0
3	A2	0/1	0/1	0/1	X	X	X
4	A3	0/1	0/1	0/1	X	X	X
5	CARD_SEL	0/1	0/1	0/1	0/1	0/1	0/1
6	PGM	0/1	0/1	0/1	1	1	1

NCN6004A

Table 2. Programming Functions (Conditions at start-up are in **Bold**)

(HEX)	PGM	A3	A2	A1	A0	CARD_SEL	CRD_VCC #A	CRD_VCC #B	CRD_CLK #A	CRD_CLK #B	CRD_DET #A	CRD_DET #B	CLOCK SLOPE
00	0	0	0	0	0	1	1.80 V	-	-	-	-	-	-
01	0	0	0	0	1	1	3.0 V	-	-	-	-	-	-
02	0	0	0	1	0	1	5.0 V	-	-	-	-	-	-
03	0	0	0	1	1	1	-	-	-	-	-	-	SLOW
00	0	0	0	0	0	0	-	1.80 V	-	-	-	-	-
01	0	0	0	0	1	0	-	3.0 V	-	-	-	-	-
02	0	0	0	1	0	0	-	5.0 V	-	-	-	-	-
03	0	0	0	1	1	0	-	-	-	-	-	-	SLOW
04	0	0	1	0	0	1	-	-	1/1	-	-	-	-
05	0	0	1	0	1	1	-	-	1/2	-	-	-	-
06	0	0	1	1	0	1	-	-	1/4	-	-	-	-
07	0	0	1	1	1	1	-	-	1/8	-	-	-	-
04	0	0	1	0	0	0	-	-	-	1/1	-	-	-
05	0	0	1	0	1	0	-	-	-	1/2	-	-	-
06	0	0	1	1	0	0	-	-	-	1/4	-	-	-
07	0	0	1	1	1	0	-	-	-	1/8	-	-	-
08	0	1	0	0	0	1	-	-	START	-	-	-	-
09	0	1	0	0	1	1	-	-	STOPL	-	-	-	-
0A	0	1	0	1	0	1	-	-	STOPH	-	-	-	-
0B	0	1	0	1	1	1	-	-	-	-	-	-	FAST
08	0	1	0	0	0	0	-	-	-	START	-	-	-
09	0	1	0	0	1	0	-	-	-	STOPL	-	-	-
0A	0	1	0	1	0	0	-	-	-	STOPH	-	-	-
0B	0	1	0	1	1	0	-	-	-	-	-	-	FAST
0C	0	1	1	0	0	1	-	-	-	-	NO	-	-
0D	0	1	1	0	1	1	-	-	-	-	NC	-	-
0C	0	1	1	0	0	0	-	-	-	-	-	NO	-
0D	0	1	1	0	1	0	-	-	-	-	-	NC	-
0E	0	1	1	1	0	1	-	-	CLK_D_A	-	-	-	-
0F	0	1	1	1	1	1	-	-	CLK_D_B	-	-	-	-
0E	0	1	1	1	0	0	-	-	-	CLK_D_B	-	-	-
0F	0	1	1	1	1	0	-	-	-	CLK_D_A	-	-	-

NCN6004A

Table 3. Status Pins Data

STATE (HEX)	PGM	A3	A2	A1	A0	CARD_SEL	STATUS #A	STATUS #B
00	1	X	X	0	0	X	Vcc_Vbat_OK Pass = Low VCC_OK Fail = High	
01	1	X	X	0	1	1	CRD_VCC_A In Range Pass = High Fail =Low	
02	1	X	X	1	0	1	CRD_VCCA Overloaded Pass = High Fail = Low	
03	1	X	X	1	1	1	CRD_DET_A Card Present = High	
00	1	X	X	0	0	X		VCC_OK Pass = Low VCC_OK Fail = High
01	1	X	X	0	1	0		CRD_VCC_B In Range Pass = High Fail =Low
02	1	X	X	1	0	0		CRD_VCC_B Overloaded Pass = High Fail = Low
03	1	X	X	1	1	0		CRD_DET_A Card Present = High

*The STATUS register is not affected when the NCN6004A operates in any of the programming mode. Initialized conditions upon start-up are depicted by bold characters in Table 2 and Table 4.

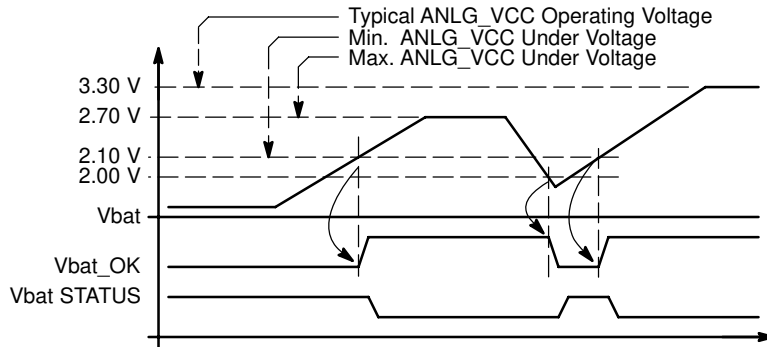

The input power supply voltage monitoring applies to the card selected.

Figure 5. Reading ANLG_VCC Status (monitoring ANLG_VCC input voltage)

SYSTEM STATES UPON UPON START-UP

Table 4. Operating Conditions Upon Start-up

CRD_VCC_A	3.0 V
CRD_VCC_B	3.0 V
CRD_CLK_A	1/1 Ratio
CRD_CLK_B	1/1 Ratio
CRD_CLK_A	START (clock is valid)
CRD_CLK_B	START (clock is valid)
CRD_CLK_A	Low Speed Slope
CRD_CLK_B	Low Speed Slope
CLOCK Route	Direct (CLK_A → A, CLK_B → B)

Depending upon the logic state at turn on present on pin 44, the system will run into a parallel mode (MUX_MODE = L) or a multiplexed mode (MUX_MODE = H). It is not possible to change the logic state once the system is running.

Similarly, depending upon the logic state present pin 45, the internal pull up resistors (I/O_A and I/O_B line) will be either connected to ANLG_VCC voltage (EN_RPU = H) or disconnected (EN_RPU = L). It is not possible to change this operating condition once the system is running.

PARALLEL/MULTIPLEXED OPERATION MODES

The logic input MUX_MODE, pin 44, provides a way to select the operation mode of the NCN6004A. Depending upon the logic level, the device operates either in a parallel mode (all the card pins, on the μ P side, are fully independent)

or in multiplexed mode (all the logic card pins, on the μ P side, share a common bus). Figure 6 shows a simplified schematic of the multiplex circuit built in the NCN6004A chip.

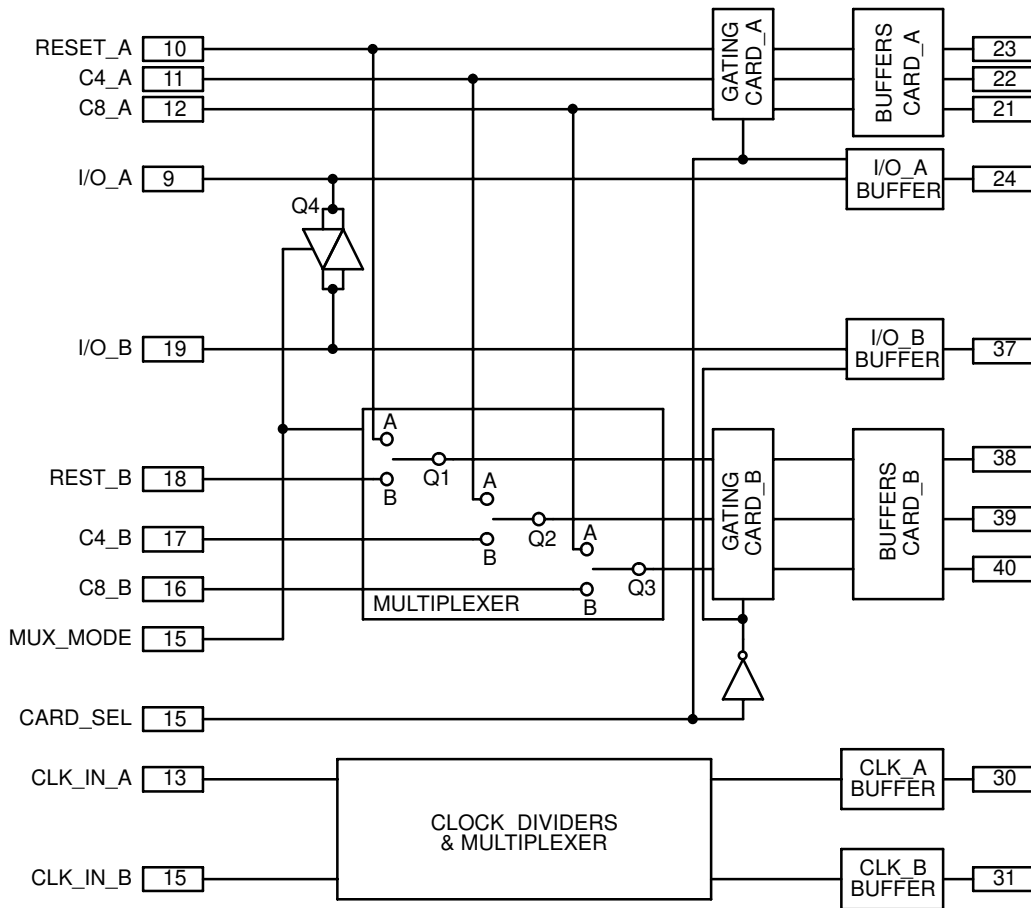

Figure 6. Simplified MUX_MODE Logic and Multiplex Circuit

In both case, the device is programmed by means of the common logic controls pins (A0, A1, A2, A3, PGM, PWR_ON, CARD_SEL and \overline{CS}). On the other hand, the logic status returned by the interface (STATUS pin 46) is shared by the two channels and can be read independently by setting CARD_SEL accordingly.

The card related signals connected on the μ C side are multiplexed or independent, depending upon the MUX_MODE state as described here below.

MUX_MODE = Low → PARALLEL MODE

When pin 44 is low, the device operates in the parallel mode. The transfer gate Q4 and the multiplexer circuit are disconnected and all the data will be carried out through their respective paths. The switches Q1, Q2 and Q3 are flipped to the B position, thus providing a direct connection from port B control signals to CARD_B

All the CARD_A and CARD_B signals are independent and both cards can operate simultaneously, the data

transaction can take place at the same time and processed independently. Of course, the microcontroller must have the right data bus available to handle this process.

However, it is not possible to change the operating mode once the system has been started. If such a function is needed, one must pull down the related NCN6004A power supply, change the MUX_MODE logic level, and re-start the interface.

MUX_MODE = High → MULTIPLEXED MODE

When pin 44 is High, the device operates in a multiplexed mode and all the card signals are shared between CARD_A and CARD_B, except the input clocks which are independent at any time. The RST_B, C4_B and C8_B pins are preferably left open at PCB level. The I/O_B pin must be left open and cannot be connected to any external signal or bias voltages.

The transfer gate Q4 is switched ON, depending upon the CARD_SEL logic level, the I/O data will be transferred

to either CARD_A or CARD_B. It is neither possible to connect directly I/O_A to I/O_B nor to connect the I/O_B pin to ground or voltage supply.

The multiplexer is activated and the CARD_SEL signal is used to select the card in use for a given transaction. The switches Q1, Q2 and Q3 are swapped to the A position, thus providing a path for the control signals applied to the CARD_A side.

When the CARD_SEL signal flips from one card to the other, the previous logic states of the on going card are latched in the chip and the related output card pin are maintained at the appropriate levels. When the system resumes to the previous card, the latches return to the transparent operation and the signals presented by the μ P take priority over the previously latched states.

On the other hand, the input clocks (CLK_IN_A and CLK_IN_B) are maintained independent and can be routed to either CARD_A or CARD_B according to the programming functions given in Table 2.

CARD POWER SUPPLY TIMING

When the PWR_ON signal is high, the associated CRD_VCC_A or CRD_VCC_B power supply rise time depends upon the current capability of the DC/DC converter together with the external inductors L1/L2 and the reservoir capacitor connected across each card power supply pin and GROUND.

On the other hand, at turn off, the CRD_VCC_A and CRD_VCC_B fall times depend upon the external reservoir capacitor and the peak current absorbed by the internal NMOS device built across each CRD_VCC_A/CRD_VCC_B and GROUND. These behaviors are depicted by Figure 7, assuming a 10 μ F output capacitor.

Since none of these parameters can have infinite values, the designer must take care of these limits if the t_{ON} or the t_{OFF} provided by the data sheets does not meet his requirement.

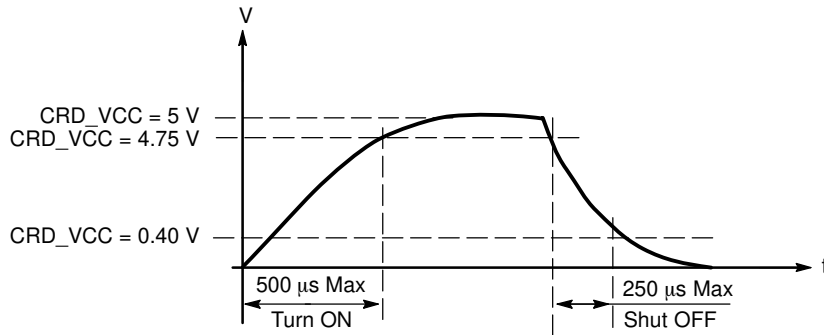

Figure 7. Card Power Supply Turn ON and Shut OFF Typical Timings

POWER DOWN OPERATION

The power down mode can be initiated by either the external MPU or by the internal error condition. The communication session is terminated immediately, according to the ISO7816-3 sequence. On the other hand, the MPU can run the Stand By mode by forcing CS = H, leaving the chip in the previous operating mode.

When the card is extracted, the interface will detect the operation and will automatically run the Power Down Sequence of the related card as described by the ISO/CEI 7816-3 sequence depicted in Figure 8 and illustrated by the oscillogram in Figure 9.

- Force RST to Low
- Force CLK to Low, unless it is already in this state
- Force C4 and C8 to Low
- Force CRD_IO to Low
- Shut Off the CRD_VCC Supply

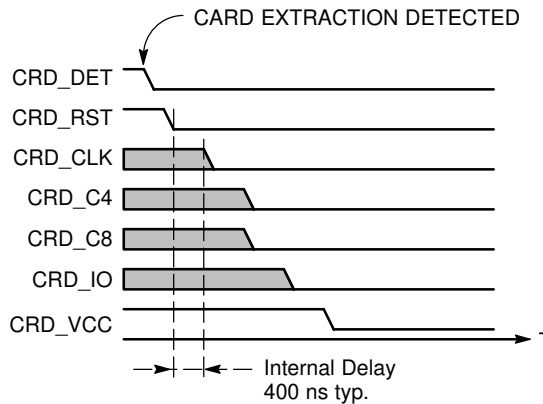

Figure 8. Card Power Down Sequence

NCN6004A

On the other hand, the Power Down sequence is automatically activated when the V_{bat} voltage drops below the VCC_OK level, regardless of the logic conditions

present on the control pins, or when the related CRD_VCC_x output voltage reaches the overload condition.

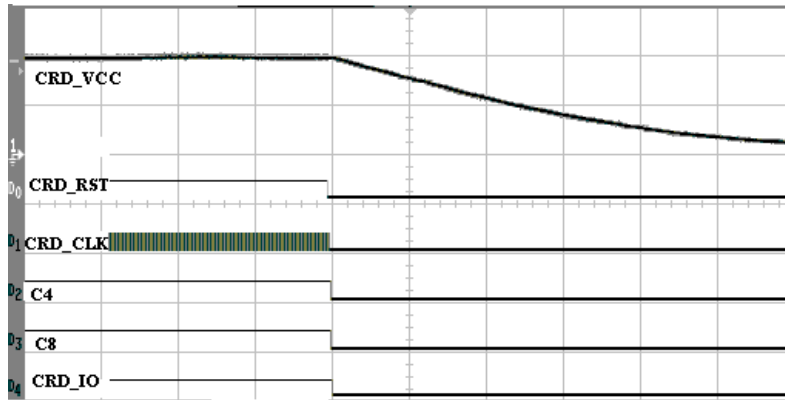

Figure 9. Power Down Sequence

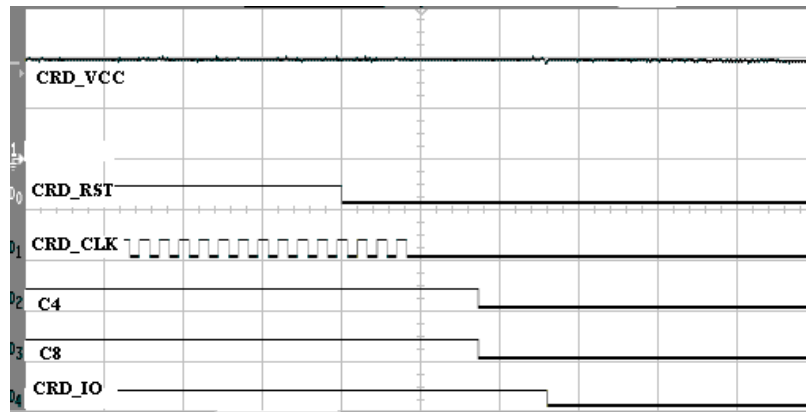

Figure 10. Power Down Sequence: Timing Details

CARD DETECTION

The card detector circuit provides a constant low current to bias the CRD_DET_A and CRD_DET_B pins, yielding a logic High when no card is present and the external switch is Normally Open type. The internal logic associated with pins 20 and 41 provides a programmable selection of the slope card detection. The transition is filtered out by the internal digital filter circuit, avoiding false interrupt. In addition to the typical 50 μs delay, the MPU shall provide an additional delay to cope with the mechanical stabilization of the card interface (typically 1 ms), prior to valid the CRD_VCC_A or CRD_VCC_B supply.

When a card is inserted, the detector circuit asserts \overline{INT} = Low as depicted before, the external μP being responsible to clear the interrupt signal, taking the necessary actions. When the NCN6004A detects a card extraction, the power down sequence is automatically activated for the related interface section, regardless of the PWR_ON state, and the \overline{INT} pin is asserted Low. It is up to the external MPU to clear this interrupt by pulsing the \overline{CS} pin.

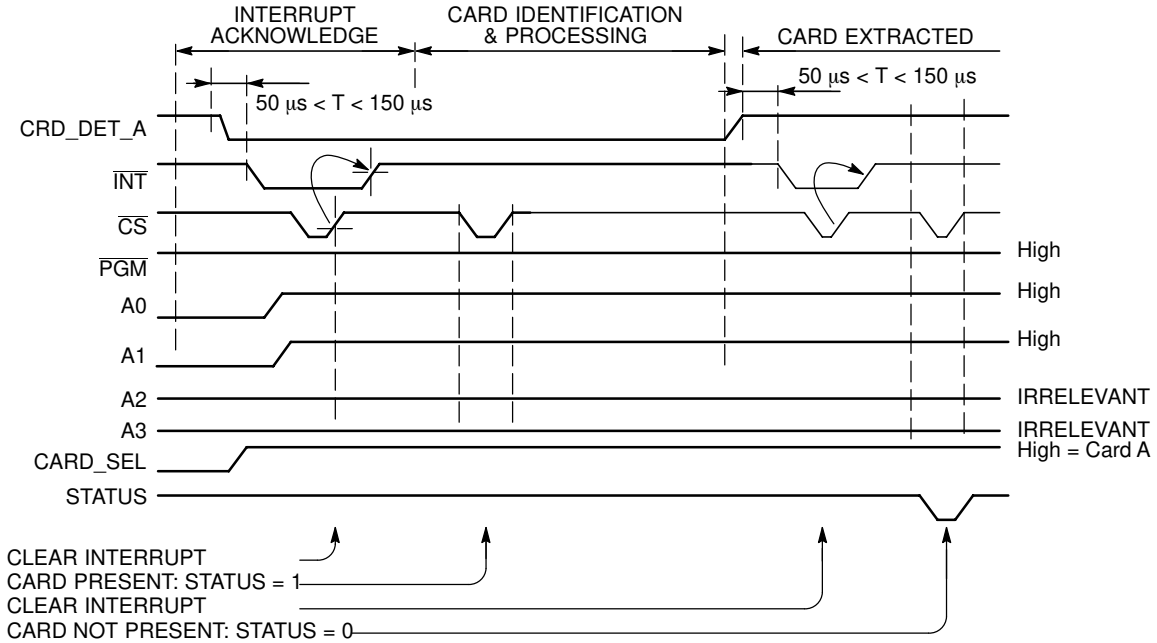

Figure 11. Typical Interrupt Sequence

The interrupt signal can be cleared either by a positive going slope on the Chip Select pin as depicted in Figure 11, or by forcing the PWR_ON signal High (keeping \overline{CS} = Low) for the related card.

The polarity of the card detection switch can be either Normally Open or Normally Close and is software controlled as defined here below and in Table 2.

Table 5. Card Detection Polarity

CS	PGM	A3	A2	A1	A0	CARD_SEL	CRD_DET_A	CRD_DET_B
1	X	X	X	X	X	X	Qn -1	Qn -1
0	1	X	X	X	X	X	Qn -1	Qn -1
0	0	1	1	0	0	1	Normally Open	Qn -1
0	0	1	1	0	1	1	Normally Close	Qn -1
0	0	1	1	0	0	0	Qn -1	Normally Open
0	0	1	1	0	1	0	Bn -1	Normally Close

*The polarity change is validated upon the next positive \overline{PGM} transient.

POWER MANAGEMENT

The main purpose of the power management is to provides the necessary output voltages to drive the 1.80 V, 3.0 V or 5.0 V smart card types. On top of that, the DC/DC converter efficiency must absorb a minimum current on the V_{bat} supply.

Beside the power conversion, in the Stand by mode ($PWR_ON = L$), the power management provides energy to the card detection circuit only. All the card interface pins are forced to ground potential, saving as much current as possible out of the battery supply.

In the event of a power up request coming from the external MPU ($CARD_SEL = H/L$, $PWR_ON = H$, $\overline{CS} = L$), the power manager starts the DC/DC converter related to the selected interface section.

When the selected section (either CRD_VCC_A or CRD_VCC_B) voltage reaches the programmed value (1.8 V, 3.0 V or 5.0 V), the circuit activates the card signals according to the following sequence:

$CRD_VCC_x \rightarrow CRD_IO_x \rightarrow CRD_C4_x \rightarrow CRD_C8_x \rightarrow CRD_CLK_x \rightarrow CRD_RST_x$

The logic level of the data lines are asserted High or Low, depending upon the state forced by the external MPU, when

the start-up sequence is completed. Under no situation the NCN6004A shall automatically launch a smart card ATR sequence.

At the end of the transaction, asserted by the MPU ($CARD_SEL = H/L$, $PWR_ON = L$, $\overline{CS} = L$), or under a card extraction, the ISO7816-3 power down sequence takes place:

$CRD_RST_x \rightarrow CRD_CLK_x \rightarrow CRD_C4_x \rightarrow CRD_C8_x \rightarrow CRD_IO_x \rightarrow CRD_VCC_x$

When $\overline{CS} = H$, the bi-directional I/O lines (pins 9 and 19) are forced into the High impedance mode to avoid signal collision with any data coming from the external MPU.

OUTPUT VOLTAGE PROGRAMMING

The internal logic provides a reliable circuit to activate any of the DC/DC converters safely. In particular, the Turn On/Turn Off of these converters is edge sensitive and controlled by the rising/falling edges of the PWR_ON signal applied with Chip Select pin Low. The $CARD_SEL$ signal is used to select either CRD_VCC_A or CRD_VCC_B as defined by the functions programming in Table 2.

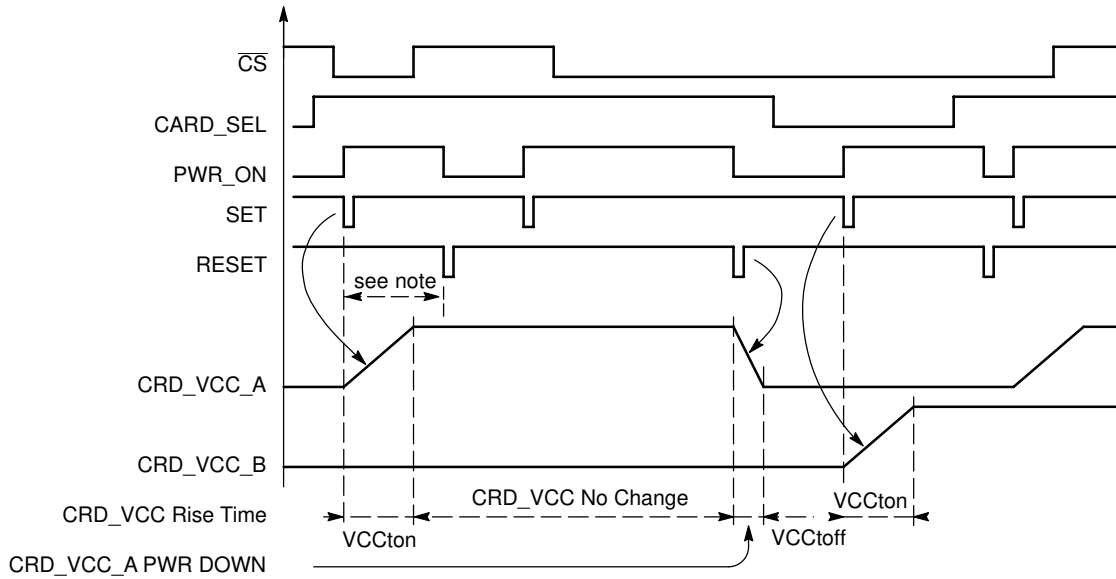

Note : minimum 1 ms delay before to send a power Off command to the same selected output is recommended.

Figure 12. Card Power Supply Controls

Although it is possible to change the output voltage straightly from 5.0 V to 1.80 V, care must be observed as the stabilization time will be relatively long if no current is absorbed from the related output pin.

According to the typical sequence depicted, it is not possible to program simultaneously the two DC/DC

converters, but two separate sequences must take place. On top of that, since the circuit is edge sensitive, the PWR_ON signal must present such a transient when a given state is expected for the converter. The PWR_ON and \overline{CS} timings definitions are given in Figure 13.

NCN6004A

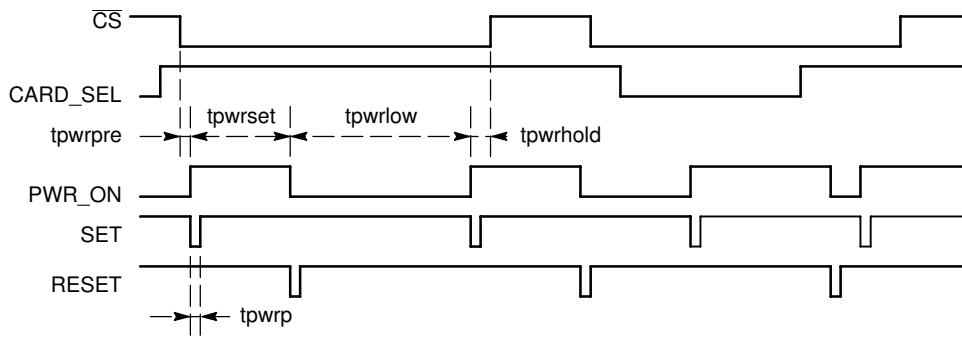

NOTE: $tpwrset$: This delay is necessary to latch-up the PWR_ON condition and does not represent the CRD_VCC output voltage rise time.
 $tpwrlow$: This delay includes the internal ISO7816-3 power down sequence to make sure the DC/DC converter is fully deactivated.

Figure 13. Power On Sequence Timings

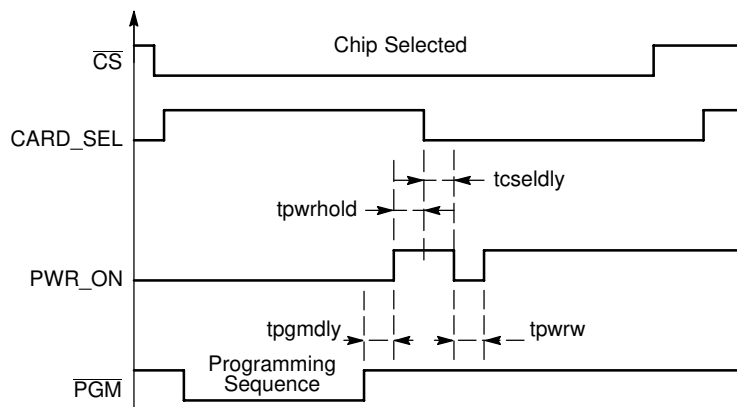

NOTE: $tpwrw$: This delay represents the minimum pulse width needed to write the PWR_ON status into the associated DC/DC latch

Figure 14. Power On and CARD_SEL Sequence Timings

DC/DC CONVERTER

The power conversion is carried out either in step up or step down mode. The operation is fully automatic and, beside the output voltage programming, does not need any further adjustments.

The simplified DC/DC converter, given in Figure 15, is based on a full bridge structure capable to handle either step up or step down power supply using an external inductor. This structure brings the capability to operate from a wide range of input voltage, while providing the accurate 1.80 V, 3.0 V or 5.0 V requested by the smart cards. Beside the accuracy, the major aim of this structure is the high efficiency necessary to save energy taken from the battery. On the other hand, using two independent converters provides a high flexibility and prevent a total system crash in the event of a failure on one of the card connected to the interface.

OPERATION

NOTE: Described operation makes reference to CARD_A and can be applied to CARD_B.

The system operates with a two cycles concept:

1. Cycle 1: Q15 and Q4 are switched ON and the inductor L1 is charged by the energy supplied by the external battery. During this phase, the pairs Q1/Q16 and Q2/Q3 are switched OFF. The current flowing into the two MOSFET Q1 and Q4 is internally monitored and will be switched OFF when the I_{peak} value (depending upon the programmed output voltage value) is reached. At this point, Cycle 1 is completed and Cycle 2 takes place. The ON time is a function of the battery voltage and the value of the inductor network (L and Zr) connected across pins 26/27 and 34/35. A 4 μ s time out structure makes sure the system does run in a continuous Cycle 1 loop.
2. Cycle 2: Q1 and Q16 are switched ON and the energy stored into the inductor L1 is dumped into the external load through Q16. During this phase, the pair Q15/Q4 and the pair Q2/Q3 are switched OFF. The current flow period is constant (900 ns typical) and Cycle 1 repeats after this time if the CRD_VCC voltage is below the specified value.

NCN6004A

When the output voltage reaches the specified value (1.80 V or 3.0 V or 5.0 V), Q1 and Q16 are switched OFF immediately to avoid over voltage on the output load. In the mean time, the two extra NMOS Q2 and Q3 are switched ON to fully discharge any current stored into the inductor, avoiding ringing and voltage spikes over the system. Figure 16 illustrates the theoretical basic waveforms present in the DC/DC converter.

The control block gives the logic states according to the bits provided by the external μP . These controls bits are applied to the selected DC/DC converter to generate the programmed output voltage. The MOS drive block includes the biases necessities to drive the NMOS and PMOS devices as depicted in the block diagram given Figure 15.

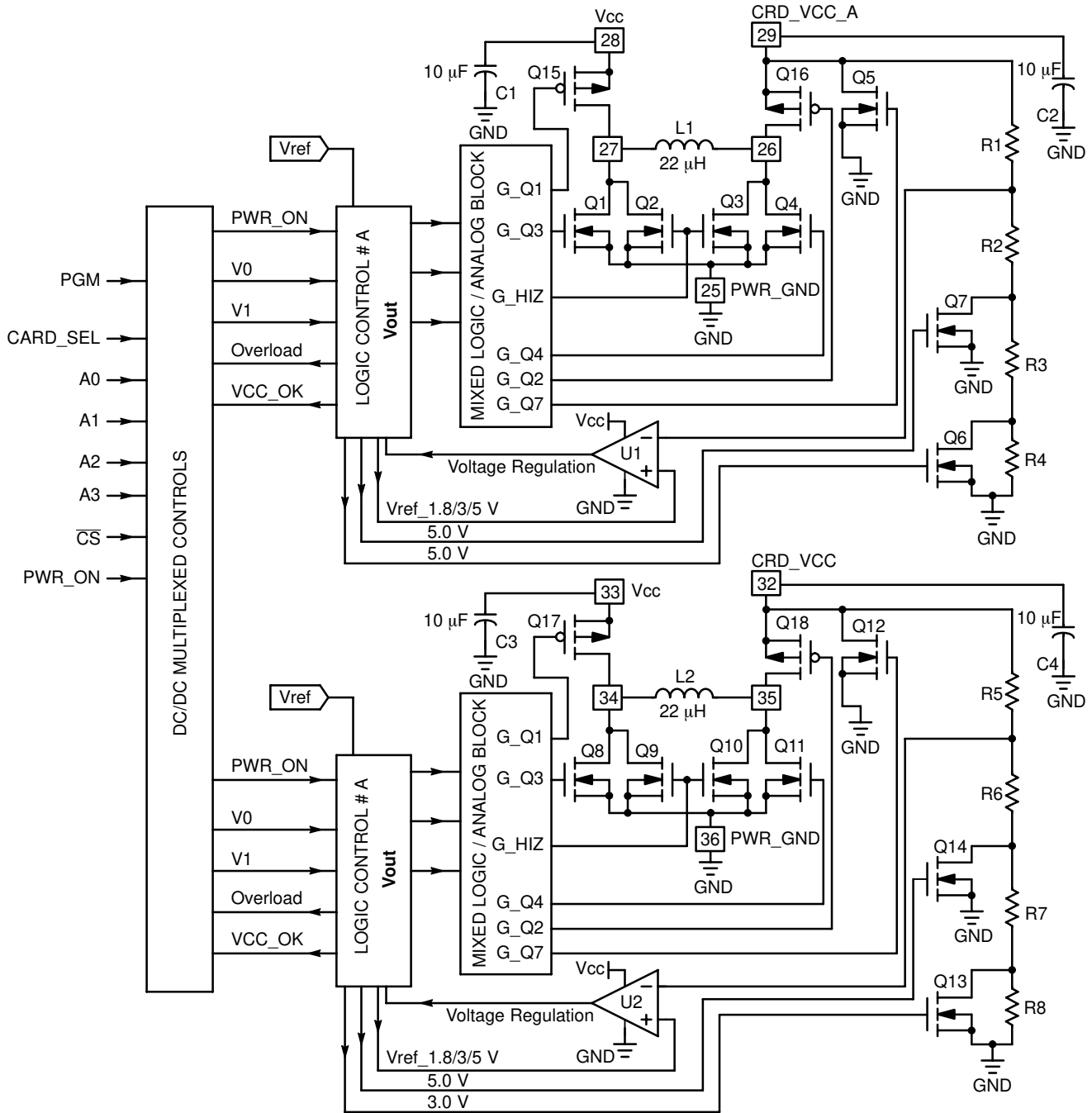

Figure 15. Basic DC/DC Converter Diagram

NCN6004A

Since the output inductor L1 and the reservoir capacitor C1 carry relative high peak current, low ESR devices must be used to prevent the system from poor output voltage ripple and low efficiency. Using ceramic capacitors, X5R or X7R type, are recommended, splitting the 10 μF in two separate parts when there is a relative long distance between

the CRD_VCC_x output pin and the card VCC input. On the other hand, the inductor shall have an ESR below 1.0 Ω to achieve the high efficiency over the full temperature range. However, inductor with 2.0 Ω ESR can be used when a slight decrease of the efficiency is acceptable at system level.

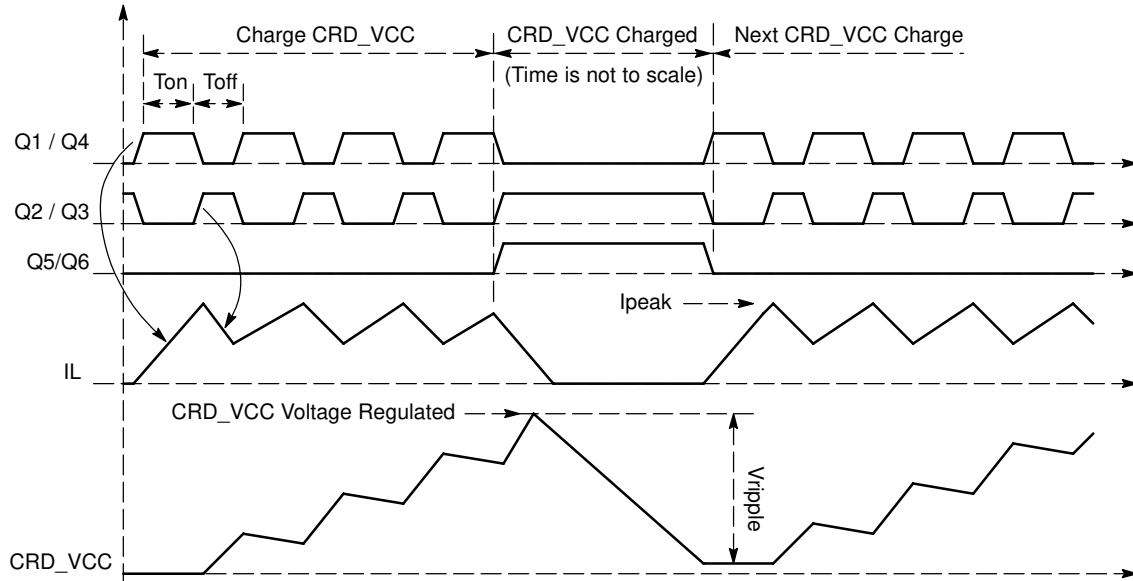

Figure 16. Theoretical DC/DC Operating

When the CRD_VCC is programmed to zero volt, or when the card is extracted from the socket, the active pull down Q5 rapidly discharges the output reservoir capacitor, making sure the output voltage is below 0.40 V when the card slides across the contacts.

Based on the experiments carried out during the NCN6004A characterization, the best comprise, at time of printing this document, is to use two 4.7 $\mu\text{F}/10\text{ V}/\text{ceramic}/\text{X7R}$ capacitor in parallel to achieve the CRD_VCC filtering. The ESR will not extend 50 m Ω

over the temperature range and the combination of standard parts provide an acceptable -20% to $+20\%$ tolerance, together with a low cost. Table 6 shows a quick comparison between the most common type of capacitors. Obviously, the capacitor must be SMD type to achieve the extremely low ESR and ESL necessary for this application.

Figure 17 illustrates the CRD_VCC ripple observed in the NCN6004A demo board running with X7R ceramic capacitors.

Table 6. Ceramic/Electrolytic Capacitors Comparison

Manufacturer	Type/Series	Format	Max Value	Tolerance	Typ. Z @ 500 kHz
MURATA	CERAMIC/GRM225	0805	10 $\mu\text{F}/6.3\text{ V}$	$-20\% / +20\%$	30 m Ω
MURATA	CERAMIC/GRM225	0805	4.7 $\mu\text{F}/6.3\text{ V}$	$-20\% / +20\%$	30 m Ω
VISHAY	Tantalum/594C/593C	1206	10 $\mu\text{F}/16\text{ V}$		450 m Ω
VISHAY	Electrolytic/94SV	1812	10 $\mu\text{F}/10\text{ V}$	$-20\% / +20\%$	400 m Ω
Miscellaneous	Electrolytic Low Cost	1812	10 $\mu\text{F}/10\text{ V}$	$-35\% / +50\%$	2.0 Ω

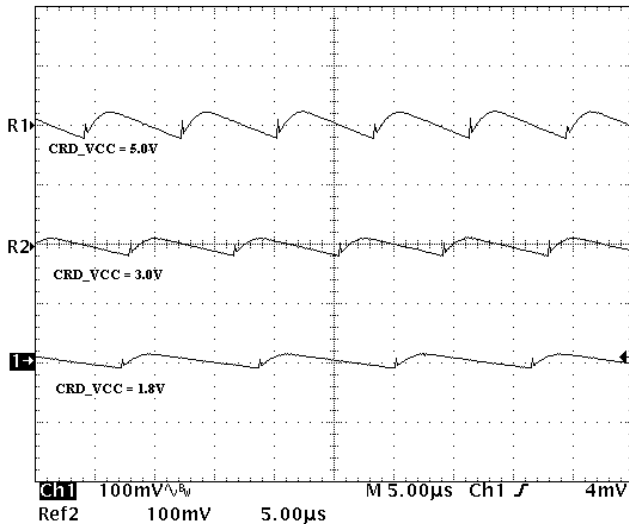

NOTE: Operating conditions under full output load.

Figure 17. Typical CRD_VCC Ripple Voltage

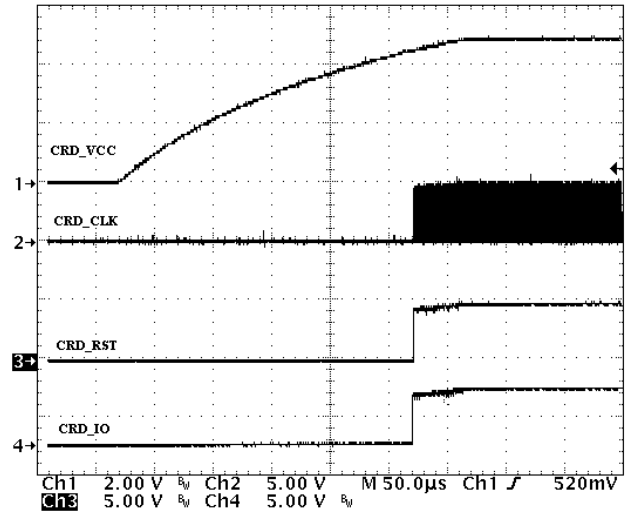

Figure 18. Typical Card Voltage Turn ON and Start-up Sequence

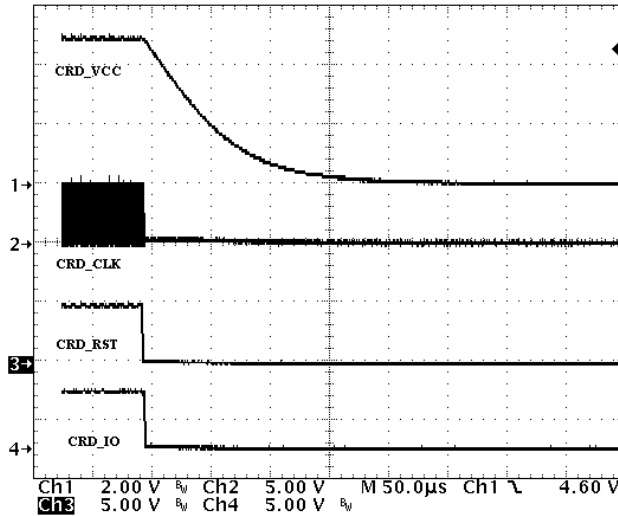

Figure 19. Typical Card Supply Turn OFF

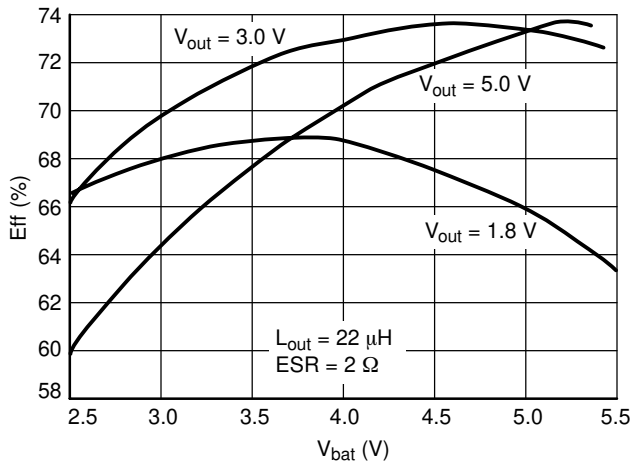

Figure 20. CRD_VCC Efficiency as a Function of the Input Supply Voltage

The curves in Figure 20, illustrate the typical behavior under full output current load (35 mA, 60 mA and 65 mA), according to EMV specifications.

During the operation, the inductor is subject to high peak current as depicted in Figure 21 and the magnetic core must sustain this level of current without damage. In particular, the ferrite material shall not be saturated to avoid uncontrolled current spike during the charge up cycle. Moreover, since the DC/DC efficiency depends upon the losses developed into the active and passive components, selecting a low ESR inductor is preferred to reduce these losses to a minimum.