



Chipsmall Limited consists of a professional team with an average of over 10 year of expertise in the distribution of electronic components. Based in Hongkong, we have already established firm and mutual-benefit business relationships with customers from,Europe,America and south Asia,supplying obsolete and hard-to-find components to meet their specific needs.

With the principle of “Quality Parts,Customers Priority,Honest Operation,and Considerate Service”,our business mainly focus on the distribution of electronic components. Line cards we deal with include Microchip,ALPS,ROHM,Xilinx,Pulse,ON,Everlight and Freescale. Main products comprise IC,Modules,Potentiometer,IC Socket,Relay,Connector.Our parts cover such applications as commercial,industrial, and automotives areas.

We are looking forward to setting up business relationship with you and hope to provide you with the best service and solution. Let us make a better world for our industry!



Contact us

Tel: +86-755-8981 8866 Fax: +86-755-8427 6832

Email & Skype: info@chipsmall.com Web: www.chipsmall.com

Address: A1208, Overseas Decoration Building, #122 Zhenhua RD., Futian, Shenzhen, China





Test Procedure for the NCP103MXTCEVB Evaluation Board

There is a collection test procedures for NCP103 demoboards. This paper offers some helpful test configuration for first contact with ONSEMI NCP103 LDO.

1. QUIESCENT CURRENT

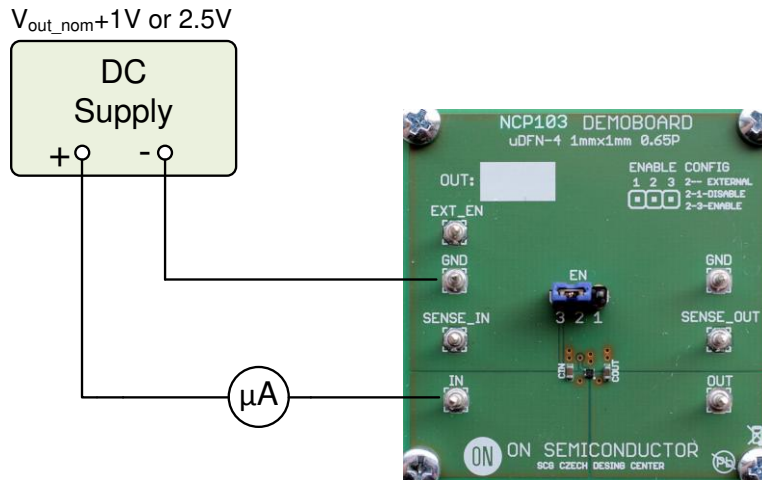

Figure 1: Test configuration for measurement I_Q , Quiescent Current

1. Connect circuit as shown figure on 1
2. Apply voltage at V_{Input} . Default test V_{input} is $V_{out_nom}+1$ V or 2.5 V whichever is greater
3. Value shown μA meter is measured quiescent current.
4. Measurement is finished. Disconnect supply voltage.

**Note – Be carefully if any device is connected on output, because leakage current can affect measurement accuracy.*



2. LOAD REGULATION

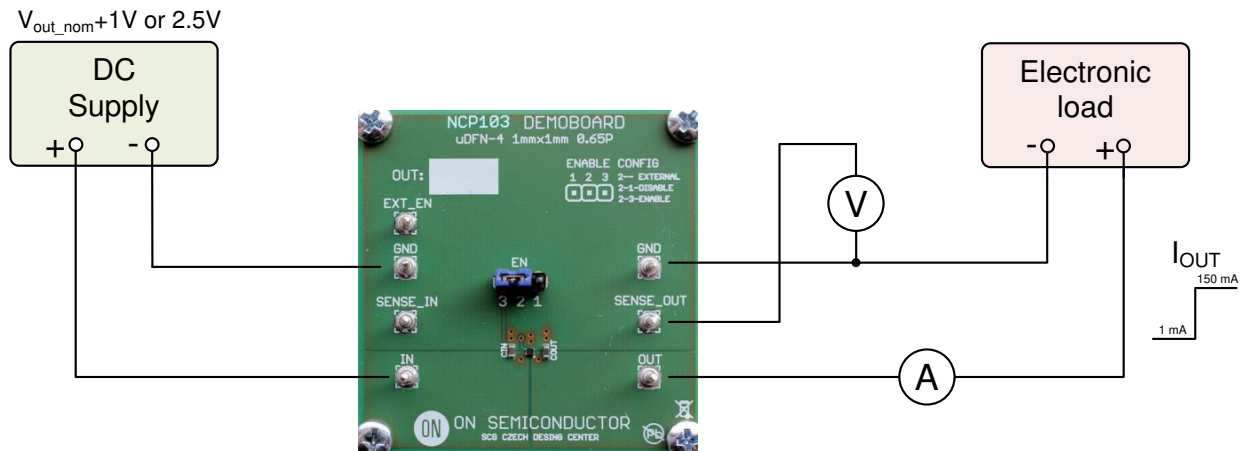

Figure 2: Test configuration for measurement REG_{LOAD} , Load Regulation

1. Connect circuit as shown figure on 2
2. Apply voltage at V_{input} . Default test V_{input} is $V_{out_nom}+1$ V or 2.5 V whichever is greater
3. Set minimal required current I_1 , e.g. 1 mA, and switch load ON.
4. Note the value V_1 from voltmeter V_o .
5. Switch load OFF and set maximal required current I_2 , e.g. 150 mA and switch load ON.
6. Note the value V_2 from voltmeter V_o .
7. Load regulation is obtained via following formula: $REG_{LOAD}=(V_1-V_2)$, [V]
8. Measurement is finished. Disconnect supply voltage.



3. LINE REGULATION

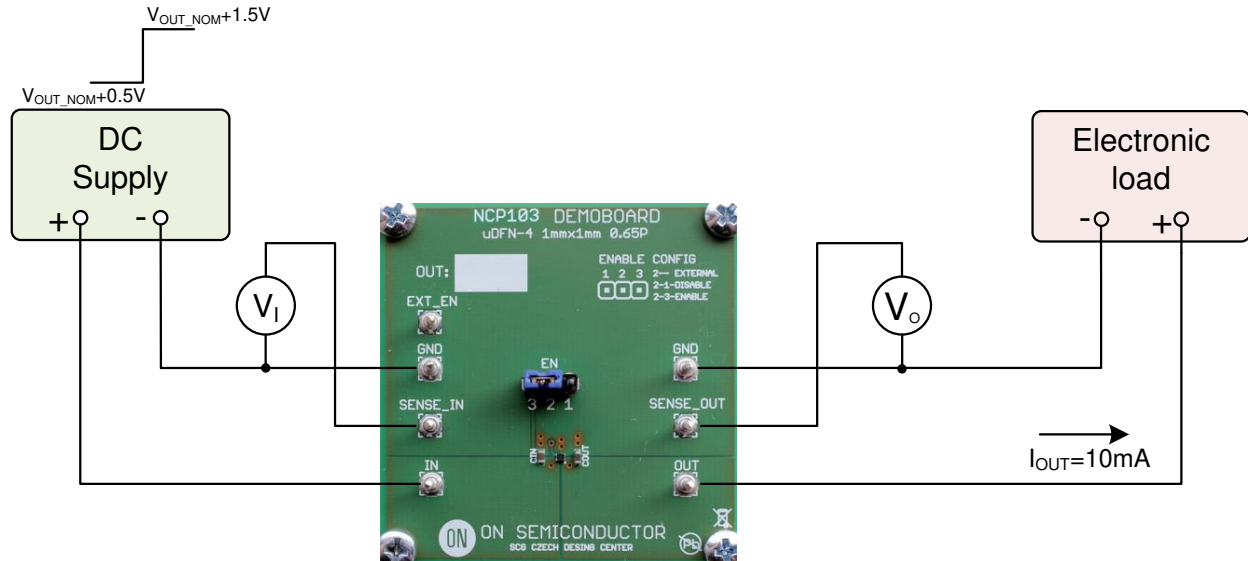

Figure 3: Test configuration for measurement REG_{LINE} , Line Regulation

1. Connect circuit as shown on figure 3
2. Set load to the required current e.g. 10 mA
3. Set minimal input voltage V_{I1} , $V_{OUT_NOM}+1V$ or 2.5V whichever is greater
4. Note the value V_{I1} and V_{O1} .
5. Set maximal input voltage $V_{I2} = 5.5 V$
6. Note the value V_{I2} and V_{O2} .
7. Load regulation is obtained via following formula: $REG_{LINE}=(V_{O1}-V_{O2})/(V_{I1}-V_{I2})$, [V/V]
8. Measurement is finished. Disconnect supply voltage.



4. ENABLE START-UP

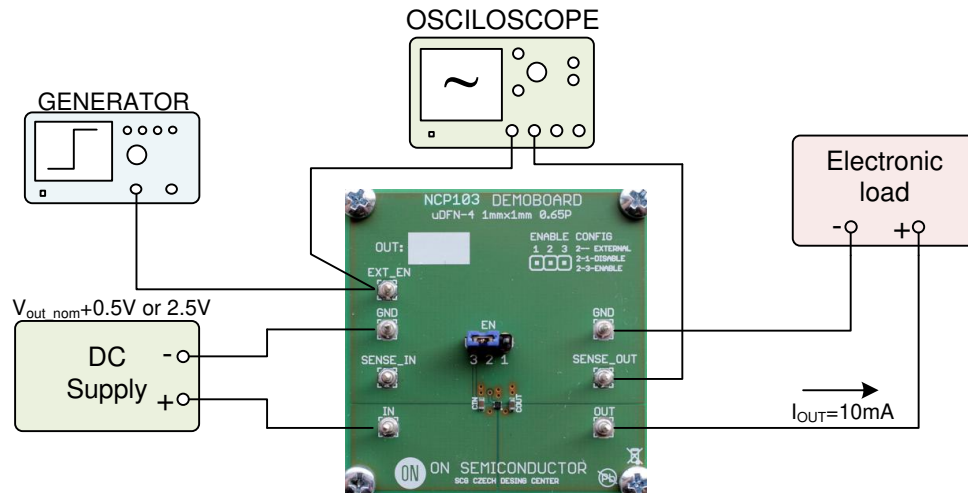

Figure 4: Test configuration for measurement enables response

1. Connect circuit as shown on figure 4
2. Set generator to SQUARE PULSE, $0.9 \leq \text{AMPLITUDE} \leq V_{\text{IN}}$, FREQUENCY=10Hz, DUTY=10%
3. Apply voltage at V_{Input} . Default test V_{Input} is $V_{\text{out_nom}} + 1 \text{ V}$ or 2.5 V whichever is greater
4. Set required I_{OUT} , e.g. 10 mA
5. Connect oscilloscope to EN signal and V_{OUTPUT} .
6. Watch enable response of the regulator after asserting EN pin.
7. Measurement is finished. Disconnect supply voltage.