



Chipsmall Limited consists of a professional team with an average of over 10 year of expertise in the distribution of electronic components. Based in Hongkong, we have already established firm and mutual-benefit business relationships with customers from,Europe,America and south Asia,supplying obsolete and hard-to-find components to meet their specific needs.

With the principle of “Quality Parts,Customers Priority,Honest Operation,and Considerate Service”,our business mainly focus on the distribution of electronic components. Line cards we deal with include Microchip,ALPS,ROHM,Xilinx,Pulse,ON,Everlight and Freescale. Main products comprise IC,Modules,Potentiometer,IC Socket,Relay,Connector.Our parts cover such applications as commercial,industrial, and automotives areas.

We are looking forward to setting up business relationship with you and hope to provide you with the best service and solution. Let us make a better world for our industry!



Contact us

Tel: +86-755-8981 8866 Fax: +86-755-8427 6832

Email & Skype: info@chipsmall.com Web: www.chipsmall.com

Address: A1208, Overseas Decoration Building, #122 Zhenhua RD., Futian, Shenzhen, China





Test Procedure for the NCP1071SOTGEVB Evaluation Board

Introduction: The NCP1071 Buck EVAL demo board is an off-line, 2 watt output, non-isolated buck converter. The output is configured for 12V_{out} at 150 mA max. The switching topology is a simple buck converter utilizing the ON Semi NCP1071, 100 kHz monolithic controller with internal MOSFET. CAUTION: The output of this converter IS NOT isolated from the AC line so caution should be taken when testing.

Equipment Required:

1. Adjustable, isolated AC power source capable of zero to 265 Vac output up to 500 mA. AC source should have the capability of measuring input power in watts. If not, an AC line analyzer or AC wattmeter should be used. Wattmeter should be capable of reading down to 50 mW (for standby power measurements.)
2. Digital volt/amp meters to measure output current and voltage to the electronic load.
3. A variable electronic load or rheostat capable of up to a 3 amp load. If an electronic load is used it is preferable to have a constant resistance load mode. The current meter on the electronic load can be used in lieu of a series, in-line ammeter.
4. Oscilloscope with probe to monitor output ripple on the demo converter.

Setup Procedure: Set the equipment as shown in the diagram below so that the output voltage and current to the demo board can be measured and the output ripple can be monitored.

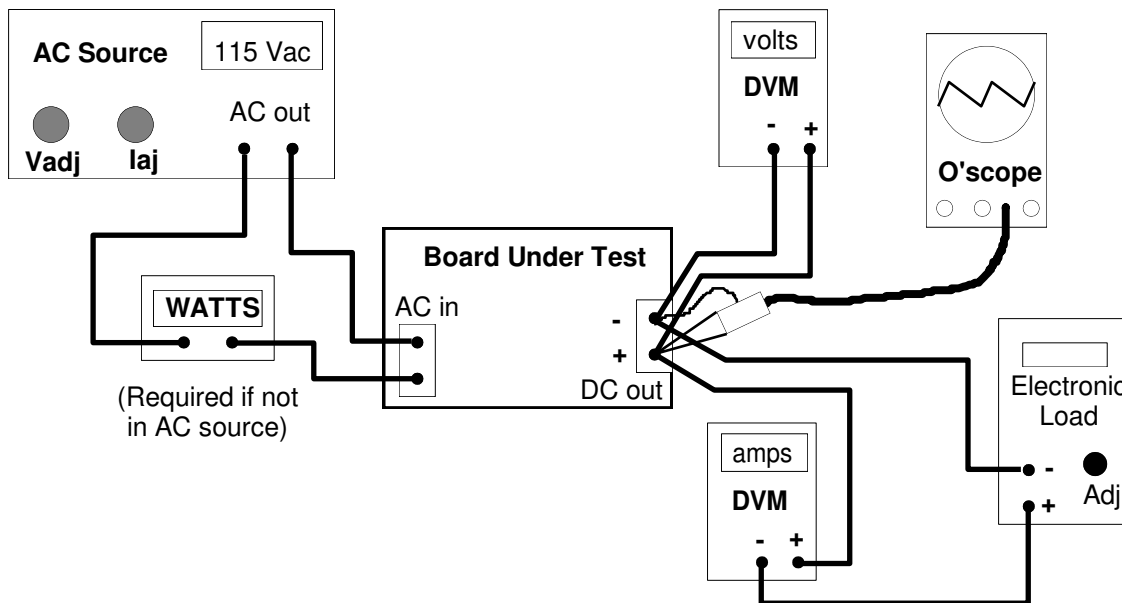

Note: Indicated output polarity on above drawing of demo board may not correspond to actual demo board. Please note output polarity as marked on demo board.

**Test Procedure:**

1. Switch the electronic load on and set to zero load; switch all of the digital meters on (assuming they are wired properly for voltage and current sensing); turn the oscilloscope on with sensing in AC mode and 100 mV per division vertical and a sweep rate of 5 uS per division. Connect the scope probe to the demo board's output terminals. **KEEP IN MIND THAT THE OUTPUT OF THE BOARD UNDER TEST IS NOT ISOLATE FROM THE AC LINE!**
2. With the AC source OFF, set the current limit on the AC source to 100 mA and the output voltage to 120 Vac.
3. Turn on the AC source and the power supply output voltage should be 14 to 15 Vdc on the DVM.
4. Adjust the electronic load from no load slowly up to 50 mA. The output voltage should drop to between 12 and 13 volts. Continue to increase the load up to 150 mA. The output voltage should be greater than 11.5 volts.
5. The output ripple (switching frequency) on the oscilloscope should be less than 150 mV peak-to-peak at full load. (Note – scope probe tip should be decoupled with a 0.1uF ceramic capacitor and ground wire should not be used to get best accuracy and max attenuation of switching noise pickup.)
6. Adjust the AC source down to 80 Vac and the power supply output should still be in spec. Return the AC source to 120 Vac.
7. While at full load (150 mA), check the efficiency at 120 Vac input. $\text{Effic} = (\text{Vout} \times \text{Iout})/\text{Pin}$. It should be greater than 65%.
8. Continue to increase the load slowly and the over-current protection should kick in at around 350 mA. This should result in a “hick-up” start-stop type of operation.
9. Set the load back to 150 mA and the power supply should recover with proper output voltage.
10. Adjust the electronic load to back to zero (do not switch it off!) and check the input power (standby power). It should be below 100 mW (note: this may not be measurable with test equipment when supply in skip mode.)
11. Adjust the AC input to 230 Vac with the load at 150 mA and confirm Vout is in spec and stable.
12. Switch the AC source off and disconnect the demo board.

End of Test.