



Chipsmall Limited consists of a professional team with an average of over 10 year of expertise in the distribution of electronic components. Based in Hongkong, we have already established firm and mutual-benefit business relationships with customers from,Europe,America and south Asia,supplying obsolete and hard-to-find components to meet their specific needs.

With the principle of “Quality Parts,Customers Priority,Honest Operation,and Considerate Service”,our business mainly focus on the distribution of electronic components. Line cards we deal with include Microchip,ALPS,ROHM,Xilinx,Pulse,ON,Everlight and Freescale. Main products comprise IC,Modules,Potentiometer,IC Socket,Relay,Connector.Our parts cover such applications as commercial,industrial, and automotives areas.

We are looking forward to setting up business relationship with you and hope to provide you with the best service and solution. Let us make a better world for our industry!



Contact us

Tel: +86-755-8981 8866 Fax: +86-755-8427 6832

Email & Skype: info@chipsmall.com Web: www.chipsmall.com

Address: A1208, Overseas Decoration Building, #122 Zhenhua RD., Futian, Shenzhen, China



Test Procedure for the NCP1075NONGEVB

ON Semiconductor®



21/06/2013

Test Procedure for ON Semiconductor NCP1075NONGEVB 8 Watt, Non- Isolated, Dual Output EVAL Board

Introduction:

The NCP1075 Dual Output EVAL board is a European input (180 – 270 Vac), off-line, non-isolated, 8 watt max output, power supply for powering E-meters or white goods. The supply provides 5 volt and 8.5 volt outputs and is intended for applications that do not require galvanic isolation between the outputs and the input mains. The switching topology is a discontinuous mode flyback converter utilizing the ON Semi NCP1075 monolithic controller with internal MOSFET.

Equipment Required:

Adjustable, isolated AC power source capable of zero to 265 Vac output up to 500 mA. AC source should have the capability of measuring input power in watts. If not, an AC line analyzer or AC wattmeter should be used. Wattmeter should be capable of reading down to 50 mW (for standby power measurements.) Digital volt/amp meters to measure output current and voltage to the electronic load.

A variable electronic load or rheostat capable of up to a 3 amp load. If an electronic load is used it is preferable to have a constant resistance load mode. The current meter on the electronic load can be used in lieu of a series, in-line ammeter.

Oscilloscope with probe to monitor output ripple on the demo converter.

Setup Procedure:

Set the equipment as shown in the diagram below so that the output voltage and current to the demo board can be measured and the output ripple can be monitored. The diagram illustrates the setup for a single output board, however, the DVM and scope probes can be moved to the second output for measurements during testing, and an additional electronic load (or equivalent load) can be used for the second output.

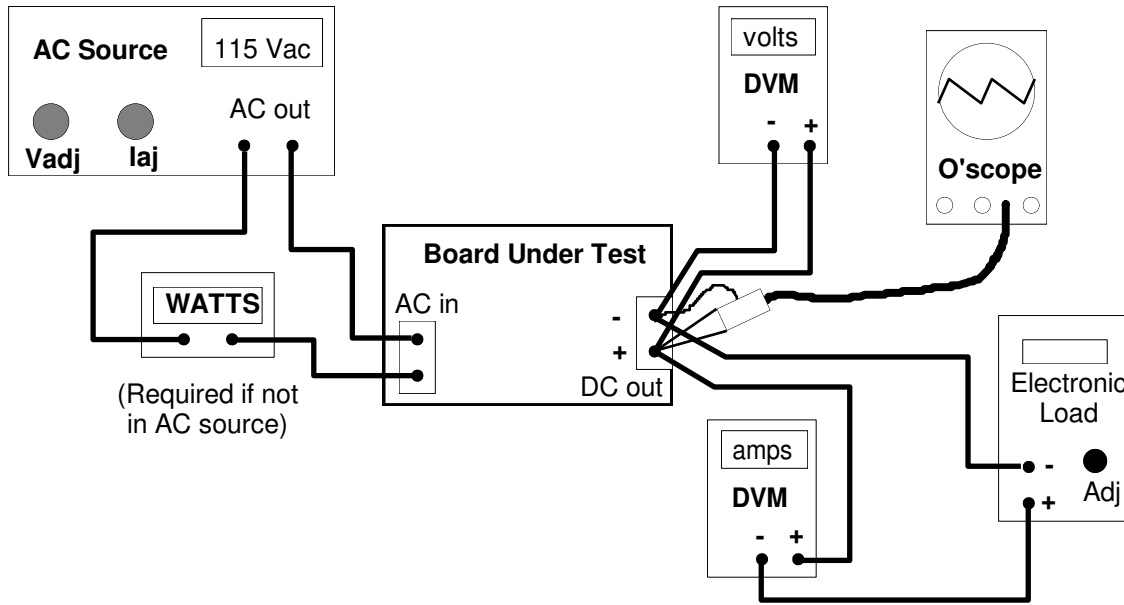

NOTE: The outputs of this board are not isolated from the AC input, so use precaution when using electronic loads or when touching or probing the board.

Test Procedure:

1. Visually check board for proper diode and electrolytic capacitor orientation and check for overall integrity of solder connections, etc.
2. Connect a 1 amp load (5 ohms) to the 5Vout terminals (VS1) and a 250 mA load (35 ohms) to the 8.5Vout terminals (VS2).
3. Connect an isolated AC source adjusted to 230Vac with current limit set to 300 mA. Connect dc voltmeters to each output. If electronic loads are used, the voltmeters in these loads can be used.
4. Switch on the AC input (230Vac) and see that both outputs come up. The 5Vout should be between 4.90 and 5.2 Vdc. If not, resistor R5 may have to be changed to trim the set point. The 8.5V output should be between 8.5 and 8.75 Vdc.
5. Measure the efficiency by calculating the output power for each channel and comparing to the input power at 230 Vac. It should be above 70%.
6. Test operation at 180 Vac input. Turn on and off here to assure startup and correct output voltage.
7. Turn AC source off and set 5Vout load to 5 amps and turn back on and make sure power supply is in hiccup overcurrent mode. Set 5Vout back to 1 amp and supply should recover with correct output voltage.
8. Turn AC off and disconnect supply. Record 5Vout voltage and efficiency values for each tested supply in notebook.

End of Test.