



Chipsmall Limited consists of a professional team with an average of over 10 year of expertise in the distribution of electronic components. Based in Hongkong, we have already established firm and mutual-benefit business relationships with customers from,Europe,America and south Asia,supplying obsolete and hard-to-find components to meet their specific needs.

With the principle of "Quality Parts,Customers Priority,Honest Operation,and Considerate Service",our business mainly focus on the distribution of electronic components. Line cards we deal with include Microchip,ALPS,ROHM,Xilinx,Pulse,ON,Everlight and Freescale. Main products comprise IC,Modules,Potentiometer,IC Socket,Relay,Connector.Our parts cover such applications as commercial,industrial, and automotives areas.

We are looking forward to setting up business relationship with you and hope to provide you with the best service and solution. Let us make a better world for our industry!



## Contact us

Tel: +86-755-8981 8866 Fax: +86-755-8427 6832

Email & Skype: info@chipsmall.com Web: www.chipsmall.com

Address: A1208, Overseas Decoration Building, #122 Zhenhua RD., Futian, Shenzhen, China



# NCP1093, NCP1094

## Integrated IEEE 802.3at PoE-PD Interface Controller

### Description

The NCP1093 and NCP1094 are members of ON Semiconductor's high power HIPO™ Power over Ethernet Powered Device (PoE-PD) product family and integrate an IEEE 802.3at PoE-PD interface controller.

Both variants incorporate the required functions such as detection, classification, under voltage lockout, inrush and operational current limit. A power good and NCLASS\_AT signal have been added to guarantee proper enabling/disabling of the DC-DC controller for both type-I and type-II operation. In addition, the NCP1093 offers a programmable under-voltage while the NCP1094 provides an auxiliary pin for applications supporting auxiliary supplies.

The NCP1093 and NCP1094 are fabricated in a robust high voltage process and integrate a rugged vertical N-channel DMOS suitable for the most demanding environments and capable of withstanding harsh environments such as hot swap and cable ESD events.

The NCP1093 and NCP1094 complement ON Semiconductor's ASSP portfolio in industrial devices and can be combined with stepper motor drivers, CAN bus drivers and other high-voltage interfacing devices to offer complete solutions to the industrial and security market.

### Features

- Fully Supports IEEE 802.3af/at Specifications
- Programmable Classification Current
- Support Two Event Classification-Signature
- Adjustable Under Voltage Lock Out (NCP1093 Only)
- Open-Drain Power Good Indicator
- 120 mA Typical Inrush Current Limit
- 680 mA Typical Operational Current Limit
- Pass Switch Disabling Input for Rear Auxiliary Supply Operation (NCP1094 Only)
- Over-temperature Protection
- Industrial Temperature Range -40°C to 85°C with Full Operation up to 125°C Junction Temperature
- 0.6 Ω Hot-swap Pass-switch
- Vertical N-channel DMOS Pass-switch Offers the Robustness of Discrete MOSFETs
- These Devices are Pb-Free, Halogen Free/BFR Free and are RoHS Compliant



ON Semiconductor®

[www.onsemi.com](http://www.onsemi.com)



DFN10  
MN SUFFIX  
CASE 485C

### PIN CONFIGURATION

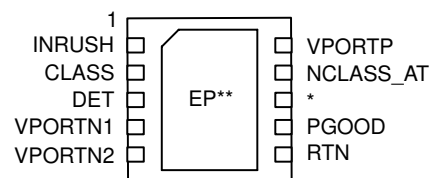

(Top View)

\*NCP1093 = UVLO

NCP1094 = AUX

\*\* Exposed pad should be connected to VPORTN

### MARKING DIAGRAMS

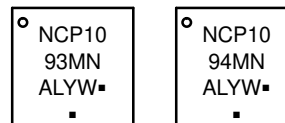

NCP109xMN = Specific Device Code

A = Assembly Location

L = Wafer Lot

Y = Year

W = Work Week

▪ = Pb-Free Package

(Note: Microdot may be in either location)

### ORDERING INFORMATION

Device	Package	Shipping†
NCP1093MNG	DFN10 (Pb-Free)	120 Units / Tube
NCP1093MNRG	DFN10 (Pb-Free)	3000 / Tape & Reel
NCP1094MNG	DFN10 (Pb-Free)	120 Units / Tube
NCP1094MNRG	DFN10 (Pb-Free)	3000 / Tape & Reel

†For information on tape and reel specifications, including part orientation and tape sizes, please refer to our Tape and Reel Packaging Specification Brochure, BRD8011/D.

# NCP1093, NCP1094

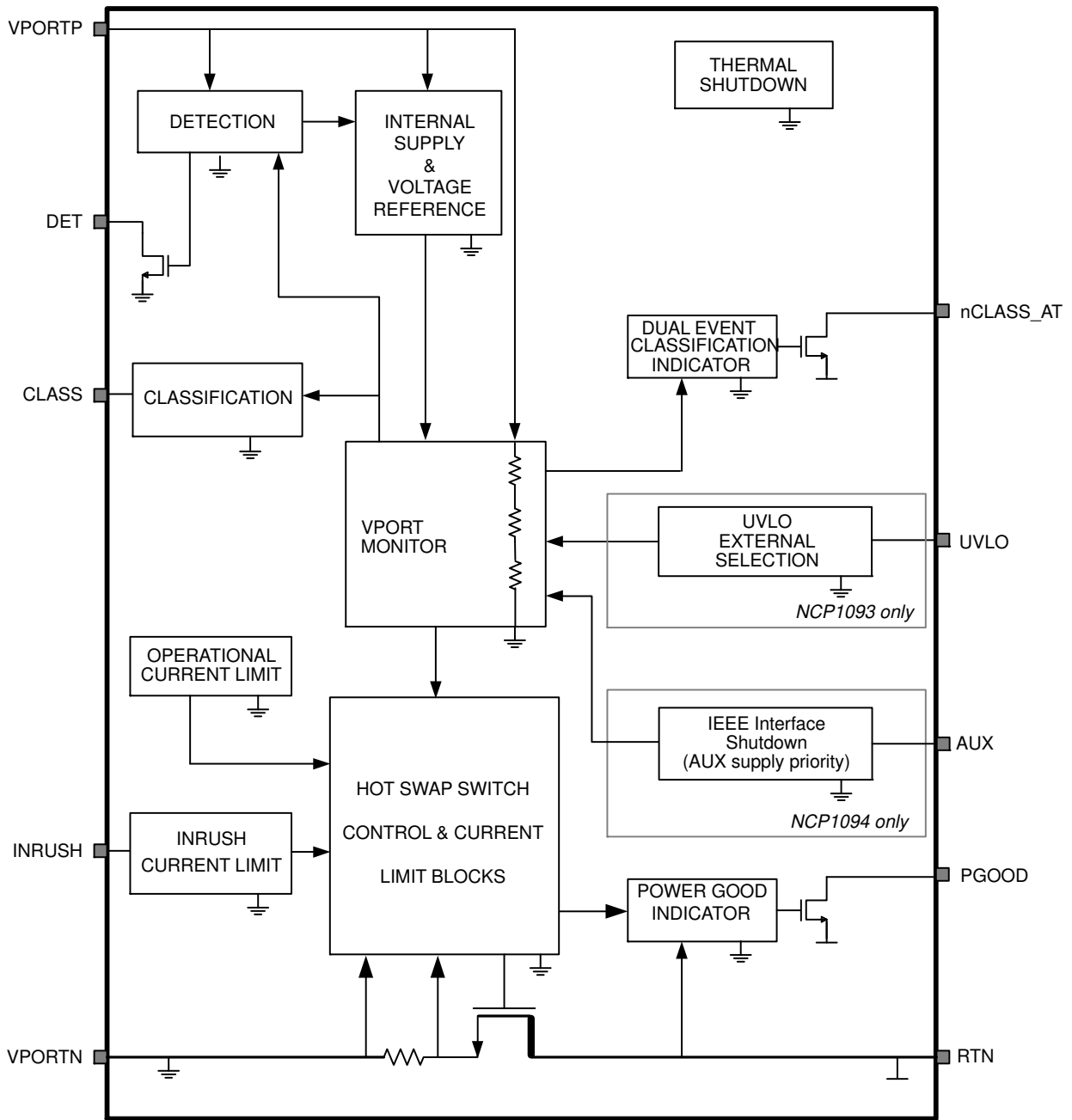

Figure 1. NCP1093/94 Functional Block Diagram

# NCP1093, NCP1094

## Simplified Application Diagrams

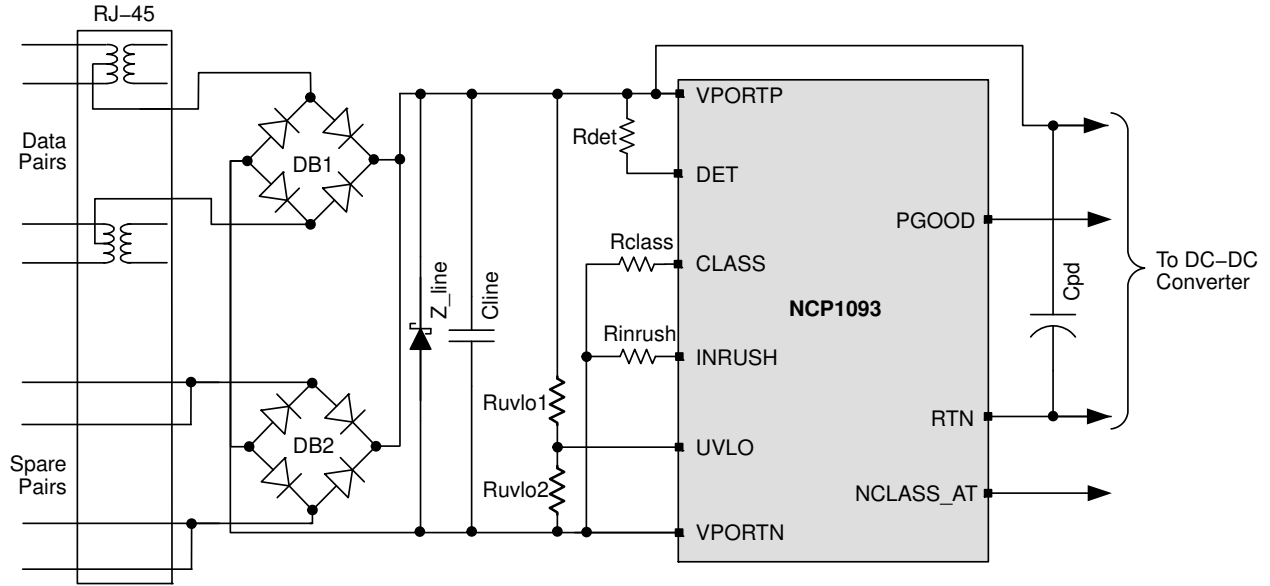

Figure 2. Typical Application Circuit using the NCP1093 with External UVLO Setting

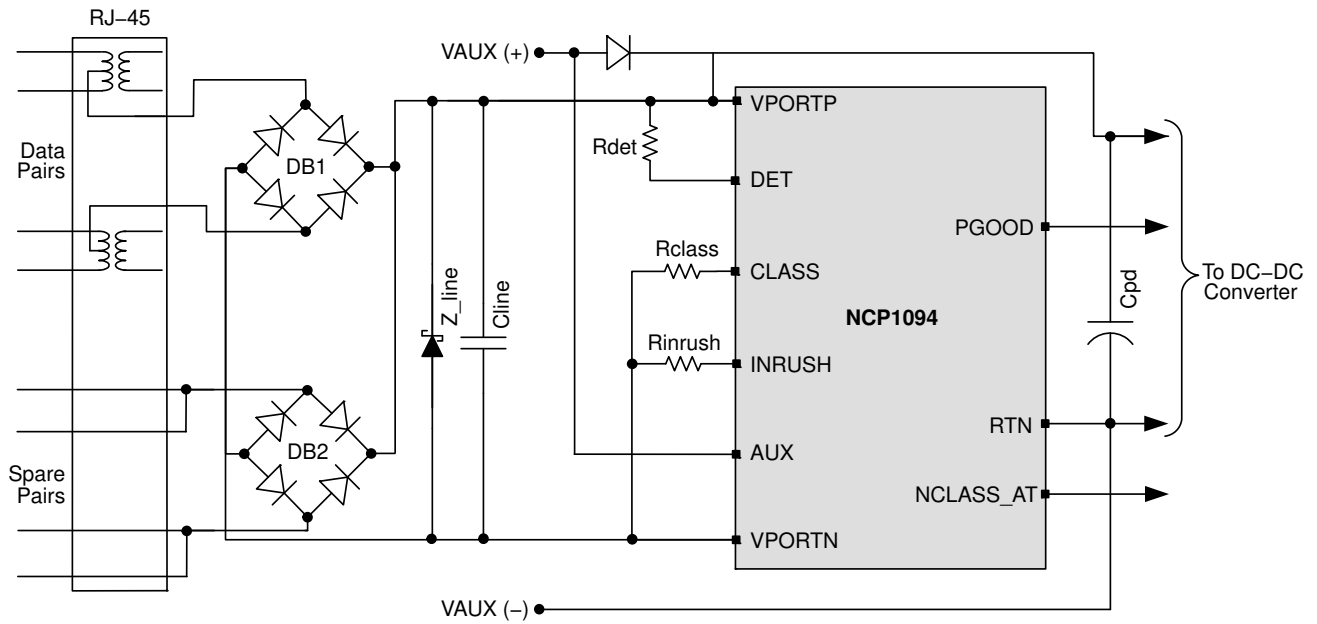

Figure 3. Typical Application Circuit using the NCP1094



# NCP1093, NCP1094

**Table 1. PIN DESCRIPTION**

Name	Pin No.		Type	Description
	NCP1093	NCP1094		
INRUSH	1	1	Output	Current limit programming pin. Connect a resistor between INRUSH and VPORTN.
CLASS	2	2	Output	Classification current programming pin. Connect a resistor between CLASS and VPORTN.
DET	3	3	Output, Open Drain	Detection pin. Connect a 24.9 kΩ resistor between DET and VPORTP for a valid PD detection signature.
VPORTN1	4	4	Ground	Negative input power. Connected to the source of the internal pass-switch
VPORTN2	5	5	Ground	Negative input power. Connected to the source of the internal pass-switch
RTN	6	6	Ground	DC-DC controller power return. Connected to the drain of the internal pass-switch
PGOOD	7	7	Output, Open Drain	Open Drain Power Good Indicator. Pin is in HZ mode when the power good signal is active.
UVLO	8	-	Input	Undervoltage lockout input. Voltage with respect to VPORTN. Connect a resistor-divider from VPORTP to UVLO to VPORTNx to set an external UVLO threshold.
AUX	-	8	Input	Auxiliary Pin. When this pin is pulled up, the Pass Switch is disabled and allows a supply transition from PSE to the rear auxiliary supply connected between VPORTP and RTN.
NCLASS_AT	9	9	Output	Active low enable signal used to verify high power operation
VPORTP	10	10	Input	Positive input power. Voltage with respect to VPORTN.
Exposed Pad	EP	EP	Ground	Exposed pad should be connected to VPORTN.

**Table 2. ABSOLUTE MAXIMUM RATINGS**

Symbol	Parameter	Min	Max	Units	Conditions
VPORTP	Input power supply	-0.3	72	V	Voltage with respect to VPORTN
RTN	Analog ground supply 2	-0.3	72	V	Pass-switch in off-state (voltage with respect to VPORTN)
CLASS	Analog output	-0.3	72	V	Voltage with respect to VPORTN
INRUSH	Analog output	-0.3	3.6	V	Voltage with respect to VPORTN
AUX	Analog input	-0.3	72	V	Voltage with respect to VPORTN
UVLO	Analog input	-0.3	3.6	V	Voltage with respect to VPORTN
PGOOD	Analog output	-0.3	72	V	Voltage with respect to RTN
T <sub>A</sub>	Ambient temperature	-40	85	°C	
T <sub>J</sub>	Junction temperature	-	125	°C	
T <sub>J</sub> , T <sub>SD</sub>	Junction temperature (Note 1)	-	175	°C	Thermal shutdown condition
T <sub>STG</sub>	Storage Temperature	-55	150	°C	
T <sub>θJA</sub>	Thermal Resistance, Junction to Air (Note 2)	50		°C/W	DFN-10
ESD-HBM	Human Body Model	2		kV	per EIA-JESD22-A114 standard
ESD-CDM	Charged Device Model	500		V	per ESD-STM5.3.1 standard
ESD-MM	Machine Model	200		V	per EIA-JESD22-A115-A standard
LU	Latch-up	±100		mA	per JEDEC Standard JESD78

Stresses exceeding those listed in the Maximum Ratings table may damage the device. If any of these limits are exceeded, device functionality should not be assumed, damage may occur and reliability may be affected.

1. T<sub>J</sub>-T<sub>SD</sub> allowed during error conditions only. It is assumed that this maximum temperature condition does not occur more than 1 hour cumulative during the useful life for reliability reasons.
2. Low θ<sub>JA</sub> is obtained with 2S2P test board (2 signal – 2 plane). High θ<sub>JA</sub> is obtained with double sideboard with minimum pad area and natural convection. Refer to Jedec JESD51 for details. The exposed pad must be connected to the VPORTN ground pin.

# NCP1093, NCP1094

## Recommended Operating Conditions

Operating conditions define the limits for functional operation and parametric characteristics of the device. Note that the functionality of the device outside the operating conditions described in this section is not warranted. Operating outside the recommended operating conditions for extended periods of time may affect device reliability.

**Table 3. OPERATING CONDITIONS** (All values are with respect to VPORTN unless otherwise noted.)

Symbol	Parameter	Min	Typ	Max	Units	Conditions
<b>INPUT SUPPLY</b>						
VPORT	Input supply voltage	0	–	57	V	VPORT = VPORTP – VPORTN

### SIGNATURE DETECTION

Offset_det1	$I_{(VPORTP)} + I_{(RTN)}$	–	2	5	$\mu\text{A}$	VPORTP = RTN = 1.9 V Rdet = 24.9 K $\Omega$
Sleep_det1	$I_{(VPORTP)} + I_{(RTN)}$	–	15	21	$\mu\text{A}$	VPORTP = RTN = 9.8 V Rdet = 24.9 K $\Omega$
Offset_det2	$I_{(VPORTP)} + I_{(RTN)} + I_{(DET)}$	73	77	81	$\mu\text{A}$	VPORTP = RTN = 1.9 V Rdet = 24.9 K $\Omega$
Sleep_det2	$I_{(VPORTP)} + I_{(RTN)} + I_{(DET)}$	390	400	412	$\mu\text{A}$	VPORTP = RTN = 9.8 V Rdet = 24.9 K $\Omega$

### CLASSIFICATION

Vcl_on	Classification current turn-on lower threshold	9.8	11.3	13	V	VPORTP rising
Vcl_off	Classification current turn-off upper threshold	21	–	24	V	VPORTP rising
Vclass_reg	Classification buffer output voltage	–	9.8	–	V	13 V < VPORTP < 21 V
Icl_bias	$I_{(vportp)}$ quiescent current during classification	–	600	–	$\mu\text{A}$	I(class) excluded 13 V < VPORTP < 21 V
Iclass0	Class 0: Rclass 4420 $\Omega$ (Note 3)	0	–	4	mA	13 V < VPORTP < 21 V
Iclass1	Class 1: Rclass 953 $\Omega$ (Note 3)	9	–	12	mA	13 V < VPORTP < 21 V
Iclass2	Class 2: Rclass 549 $\Omega$ (Note 3)	17	–	20	mA	13 V < VPORTP < 21 V
Iclass3	Class 3: Rclass 357 $\Omega$ (Note 3)	26	–	30	mA	13 V < VPORTP < 21 V
Iclass4	Class 4: Rclass 255 $\Omega$ (Note 3)	36	–	44	mA	13 V < VPORTP < 21 V
V_mark	Mark event voltage range	5.4	–	9.7	V	VPORTP falling
I_mark	$I_{(VPORTP)} + I_{(Rdet)}$ during mark event range	0.5	–	2	mA	5.4 V $\leq$ VPORTP $\leq$ 9.7 V
dR_mark	Input signature during mark event (Note 4)	–	–	12	k $\Omega$	
Vreset	Classification Reset range	4.3	4.9	5.4	V	VPORTP falling

### NCLASS\_AT 2 EVENT CLASSIFICATION INDICATOR

Inclass	$I_{(NCLASS\_AT)}$ sinking current	–	–	5	mA	
Nclass_low	NCLASS_AT voltage output low	–	0.2	0.5	V	$I_{(NCLASS\_AT)} = 2 \text{ mA}$

### UVLO – INTERNAL SETTING – NCP1093/94

Vuvlo_on	Default turn on voltage	–	37	40	V	VPORTP rising
Vuvlo_off	Default turn off voltage	29.6	31	–	V	VPORTP falling
Vhyst_int	UVLO internal hysteresis	–	6	–	V	
Uvlo_filter	UVLO On / Off filter time	–	100	–	$\mu\text{s}$	For information only

3. A tolerance of 1% on the Rclass resistor is included in the min/max values.

4. Measured with the 2 Point Measurement defined in the IEEE 802.3af standard with 5.4 V and 9.7 V the extreme values for V2 & V1.

# NCP1093, NCP1094

**Table 3. OPERATING CONDITIONS** (All values are with respect to VPORTN unless otherwise noted.)

Symbol	Parameter	Min	Typ	Max	Units	Conditions
<b>UVLO – EXTERNAL SETTING – NCP1093 ONLY</b>						
Vuvlo_pr	UVLO external programming range	25	–	50	V	VPORTP rising
Vuvlo_on2	External UVLO turn on voltage	1.14	1.2	1.26	V	
Vhyst_off2	External UVLO turn off voltage	0.95	1	1.05	V	
Uvlo_ipd	UVLO internal pull down current	–	2.5	–	μA	
<b>AUXILIARY SUPPLY SETTING – NCP1094 ONLY</b>						
Aux_h	AUX input high level voltage	3.1	–		V	
Aux_l	AUX input low level voltage	–	–	0.6	V	
Aux_pd	AUX internal pull down resistor	100	–	–	kΩ	For information only
<b>PASS-SWITCH AND CURRENT LIMITING</b>						
Ron	Pass-switch Rds-on	–	0.6	1	Ω	Measured with I(RTN) = 200 mA
I_inrush	Inrush current with Rinrush = 169 kΩ	75	120	170	mA	Measured at RTN–VPORTN = 3 V
I_ilim	Operating current limit with Rinrush = 169 kΩ	610	680	800	mA	Current limit threshold
<b>POWER GOOD INDICATOR</b>						
Vds_pgood_on	RTN–VPORTN threshold voltage required for power good status	0.8	1	1.2	V	RTN–VPORTN falling
Vds_pgood_off	RTN–VPORTN latching threshold voltage	9	10	11	V	RTN–VPORTN rising
Pgood_filter	PGOOD filter time		100		μs	Rising and falling / for information only
Ipgood	I(PGOOD) sinking current	–	–	5	mA	
Vpgood_low	PGOOD voltage output low	–	0.2	0.5	V	I(PGOOD) = 2 mA Voltage with respect to RTN
<b>CURRENT CONSUMPTION</b>						
IvportP	I(VPORTP) internal current consumption	–	600	900	μA	VPORTP = 48 V
<b>THERMAL SHUTDOWN</b>						
TSD	Thermal shutdown threshold	150	–	–	°C Tj	Tj = junction temperature
Thyst	Thermal hysteresis	–	15	–	°C Tj	Tj = junction temperature
<b>THERMAL RATINGS</b>						
Ta	Ambient temperature	–40	–	85	°C	
Tj	Junction temperature	–	–	125	°C	

3. A tolerance of 1% on the Rclass resistor is included in the min/max values.

4. Measured with the 2 Point Measurement defined in the IEEE 802.3af standard with 5.4 V and 9.7 V the extreme values for V2 & V1.

## Description of Operation

### Powered Device Interface

The integrated PD interface supports the IEEE 802.3af defined operating modes: detection signature, current source classification, undervoltage lockout, inrush and operating current limits. The following sections give an overview of these previous processes.

### Detection

During the detection phase, the incremental equivalent resistance seen by the PSE through the cable must be in the IEEE 802.3af standard specification range (23.70 kΩ to 26.30 kΩ) for a PSE voltage from 2.7 V to 10.1 V. In order to compensate for the non-linear effect of the diode bridge and satisfy the specification at low PSE voltage, the NCP1093/94 present a suitable impedance in parallel with the 24.9 kΩ Rdet external resistor. For some types of diodes (especially Schottky diodes), it may be necessary to adjust this external resistor.

The Rdet resistor has to be inserted between VPORTP and DET pins. During the detection phase, the DET pin is pulled to ground and goes in high impedance mode (open-drain) once the device exit this mode, reducing thus the current consumption on the cable.

### Classification

Once the PSE device has detected the PD device, the classification process begins. In classification, the PD regulates a constant current source that is set by the external resistor RCLASS value on the CLASS pin. Figure 4 shows the schematic overview of the classification block. The current source is defined as:

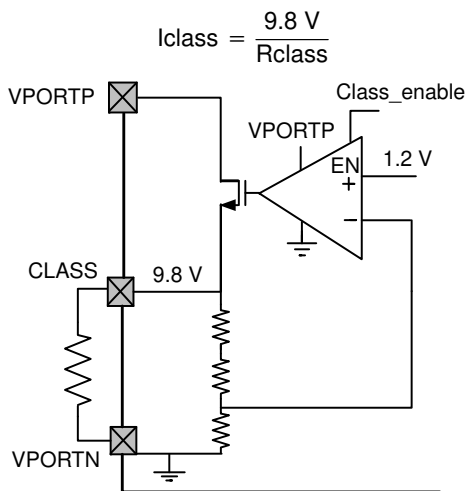

**Figure 4. Classification Block Diagram**

The NCP1093/94 is able to detect a dual event classification generated by a type 2 PSE, and flag it using its nCLASS\_AT open drain indicator.

### Power Mode

When the classification hand-shake is completed, the PSE and PD devices move into the operating mode.

### Under Voltage Lock Out (UVLO)

The NCP1093/94 incorporate a fixed under voltage lock out (UVLO) circuit which monitors the input voltage and determines when to turn on the pass switch and charge the dc-dc converter input capacitor before the power up of the application.

The NCP1093 offers a fixed or adjustable Vuvlo\_on threshold depending if the UVLO pin is used or not. In Figure 5, the UVLO pin is strapped to ground and the Vuvlo\_on threshold is defined by the internal level.

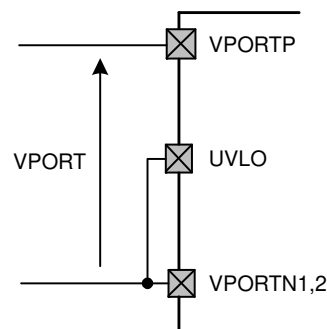

**Figure 5. Default Internal UVLO Configuration (NCP1093 only)**

To define the UVLO threshold externally, the UVLO pin must be connected to the center of an external resistor divider between VPORTP and VPORTN as shown in Figure 6.

In order to guarantee the detection signature, the equivalent input resistor made of the Ruvlo1, Ruvlo2 and Rdet should be equal to 24.9 kΩ.

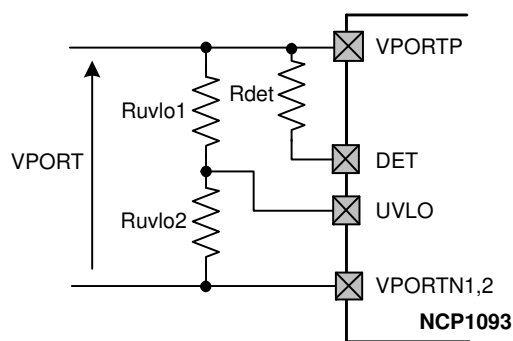

**Figure 6. Default Internal UVLO Configuration (NCP1093 only)**

For a Vuvlo\_on desired turn-on voltage threshold, Ruvlo1 and Ruvlo2 can be calculated using the following equations:

$$R_{uvlo} = \frac{24.9 \text{ k} \cdot R_{det}}{R_{det} - 24.9 \text{ k}}$$

with  $R_{uvlo1} + R_{uvlo2} = R_{uvlo}$

and  $R_{uvlo2} = \frac{1.2}{V_{uvlo\_on}} \cdot R_{uvlo}$

With:

Vuvlo\_on: Desired Turn-On voltage threshold



**Example for a Targeted  $U_{vlo\_on}$  of 35 V:**

Let's start with a  $R_{det}$  of 30.1 k $\Omega$ . This gives a  $R_{vlo}$  of 144 k $\Omega$  made with a  $R_{vlo2}$  of 4.99 k $\Omega$  and a  $R_{vlo1}$  of 140 k $\Omega$  (closest values from E96 series). Note that there is a pull down current of 2.5  $\mu$ A typ on the UVLO. Assuming the previous example, this pull down current will create a (non critical) systematic offset of 350 mV on the  $U_{vlo\_on}$  level of 35 V.

The external UVLO hysteresis on the NCP1093 is about 15 percent typical.

**Inrush and Operational Current Limitations**

Both inrush and operational current limit are defined by an external  $R_{inrush}$  resistor connected between INRUSH and VPORTN. The low inrush current limit allows smooth charge of large dc–dc converter input capacitor by limiting the power dissipation over the internal pass switch. In power mode, the operational current limit protects the pass switch

and the PD application against excessive transient current and failure on the dc–dc converter output.

Once the input supply reached the  $U_{vlo\_on}$  level, the charge of  $C_{pd}$  capacitor starts with a current limitation set to the INRUSH level. When this capacitor is fully charged, the current limit switches without any spikes from the inrush current to the operational current level and the power good indicator on PGOOD pin is turned on. The capacitor is considered to be fully charged once the following conditions are satisfied:

1. The drain–source voltage of the Pass Switch has decreased below the  $V_{ds\_pgood\_on}$  level (typical 1 V)
2. The gate–source voltage of the Pass Switch is sufficiently high (above 2 V typical) which means the current in the pass switch has decreased below the current limit.

This mechanism is depicted in the following Figure 7.

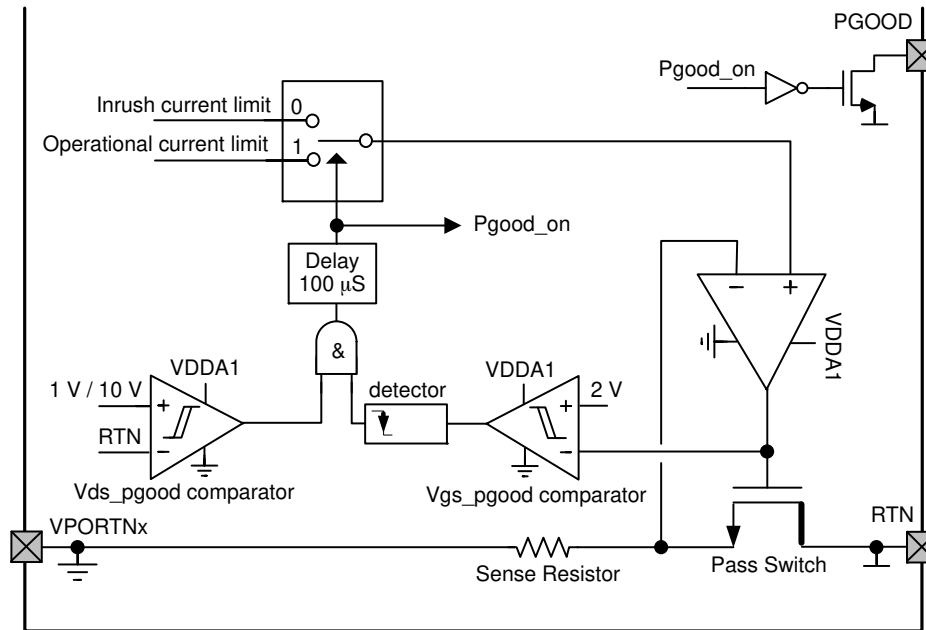

**Figure 7. Inrush and Operational Current Limitation Selection Mechanism**

The operational current limit and the power good indicator stays active as long as  $R_{TN}$  voltage stays below the  $v_{ds\_pgood\_off}$  threshold (10 V typical) and the input supply stay above the  $U_{vlo\_off}$  level. Therefore, fast and large voltage step lower than 10 V are tolerated on the input without interruption of the converter controller. Higher input transient will not affect the behavior if  $R_{TN}$  does not exceed 10 V for more than 100  $\mu$ S. Such input voltage steps may be introduced by a PSE which is switched to a higher power supply. In case  $R_{TN}$  is still above 10 V after this delay, the power good is turned off and the pass switch current limit falls back to the inrush level.

**PGOOD Indicator**

The NCP1093/94 integrate a Power Good indicator circuitry indicating the end of the dc–dc converter input capacitor charge, and the enabling of the operational current limit. This indicator is implemented on the PGOOD pin which goes in open drain state when active and which is pulled to ground during turn off.

A possible usage of this PGOOD pin is illustrated in Figure 8. During the inrush phase, the converter controller is forced in standby mode due to the PGOOD pin forcing low the under voltage lock out pin of the controller. Once the  $C_{pd}$  capacitor is fully charged, PGOOD goes in open drain state, allowing the start up sequence of the converter controller.

## NCP1093, NCP1094

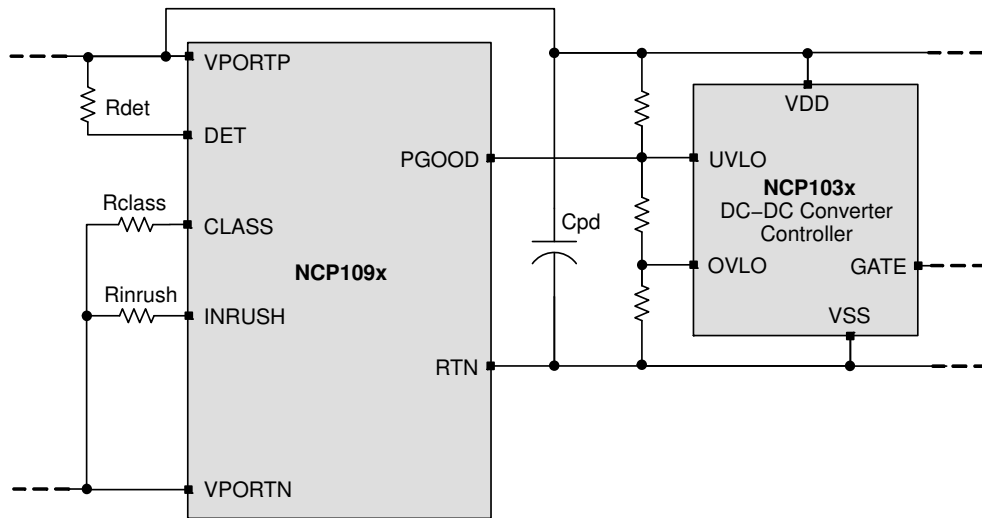

Figure 8. Power GOOD Implementation

### NCLASS\_AT Dual Event Classification Indicator

The *nCLASS\_AT* active low open drain output pin should be used to notify to the microprocessor of the Powered Device that the PSE did a one or two event Hardware Classification.

If a 2 event Hardware classification has been done and once the PD application power has been applied, the

*nCLASS\_AT* will be pulled low to RTN (ground connection of the DC/DC controller converter).

Otherwise, *nCLASS\_AT* will be in high impedance mode.

The following Scheme illustrates how the *nCLASS\_AT* pin may be configured with the processor of the Powered Device. An optocoupler is here used to guarantee to the full isolation between the cable and the application.

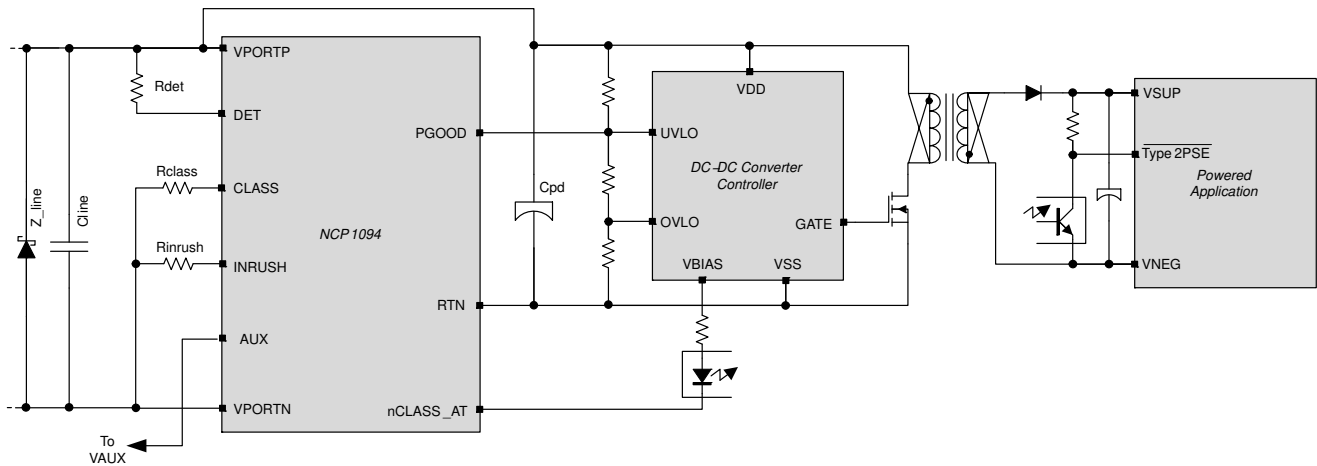

Figure 9. nClass AT indicator / possible implementation with the Powered Device

As soon as the application is powered by the DC/DC and after its initialization, the microprocessor will check if the PD interface detected a 2 event hardware classification by reading its digital input (*INI* in this example). If this *INI* pin is low, the application knows that the type 2 PSE, and therefore it can consume power till the level specified by the IEEE802.3at standard. Otherwise the application will have to perform a Layer 2 classification with the PSE.

Hereafter are described several scenarios for which the NCP109x will not enable its *nCLASS\_AT* pin during the Powered Mode:

- ◆ The PSE skipped the classification phase
- ◆ The PSE did a 1 event hardware classification (it can be a type 1 PSE or a type 2 PSE with Layer 2 only)
- ◆ The PSE did a 2 event hardware classification but it didn't well control the input voltage in the Mark voltage (it crossed the Reset range for example).

# NCP1093, NCP1094

## Auxiliary Supply

To support application connected to non-PoE enabled networks and minimize the bill of materials, the NCP1094 supports drawing power from an external supply and allows simplified designs with PoE or auxiliary supply priorities.

In most of the cases, the auxiliary supply is connected between VPORTP and RTN with a serial diode between VPORTP and VAUX, as shown in Figure 10.

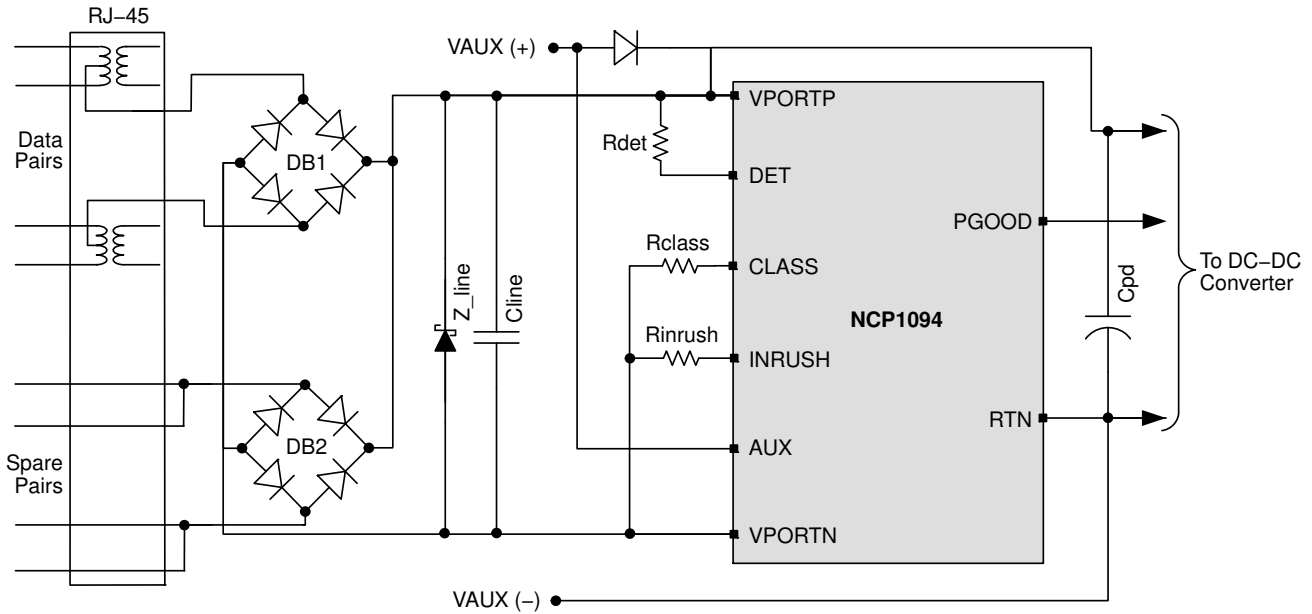

Figure 10. Auxiliary Supply Dominant PD Interface

The NCP1094 offers an AUX input pin which turns off the pass switch when pulled high. This feature is useful for PD applications where the auxiliary supply has to be dominant over the PoE supply. When the auxiliary supply is inserted on a POE powered application, the pass switch disconnection will move the current path from the PSE to the rear auxiliary supply. Since the current delivered by the PSE will go below the DC MPS level (specified in IEEE 802.3 af/at standard), the PSE will disconnect the PoE-PD

and the application will remain supplied by the auxiliary supply. The transition will happen without any power conversion interruption since the PGOOD indicator stays active (high impedance state).

Figure 11 depicts an other PD application where the POE supply is dominant over the VAUX supply. A diode D1 has been added in order to not corrupt the PD detection signature when the dc-dc converter is supplied by VAUX.

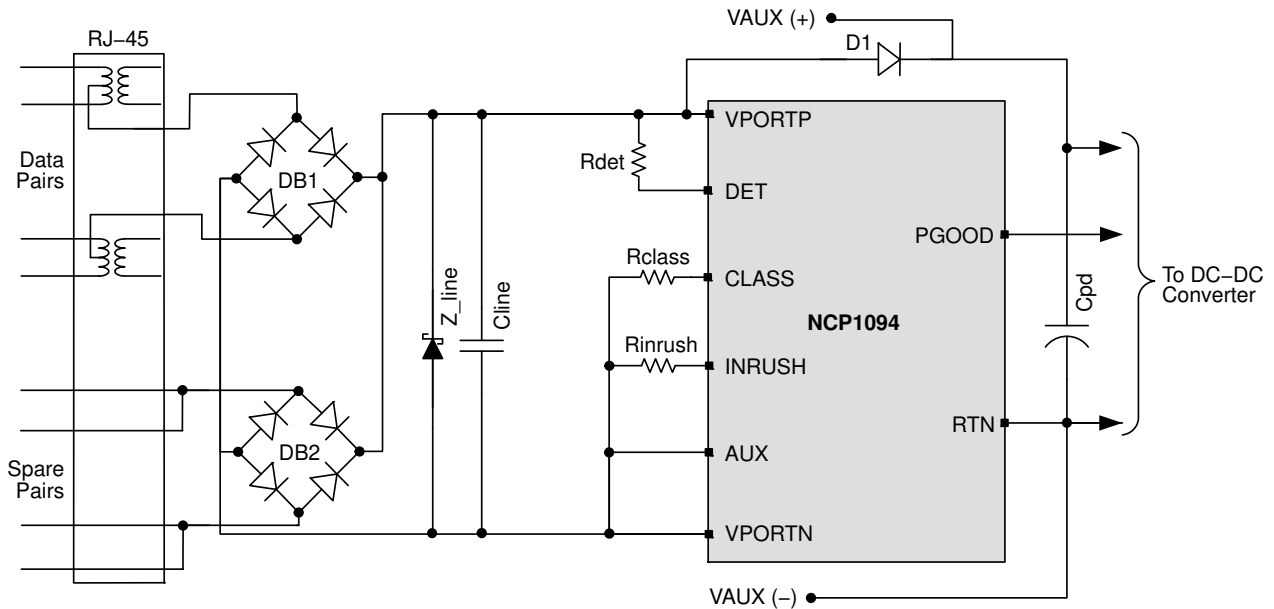

Figure 11. PoE Supply Dominant PD Interface

## NCP1093, NCP1094

### Thermal Shutdown

The NCP1093/94 include a thermal shutdown which protect the device in case of high junction temperature. Once the thermal shutdown (TSD) threshold is exceeded, the classification block, the pass switch and the PGOOD indicator are disabled. The NCP109X returns automatically to normal operation once the die temperature has fallen below the TSD low limit.

### Company or Product Inquiries

For more information about ON Semiconductor's Power over Ethernet products visit our Web site at <http://www.onsemi.com>.

# NCP1093, NCP1094

## PACKAGE DIMENSIONS

DFN10, 3x3, 0.5P  
CASE 485C  
ISSUE E

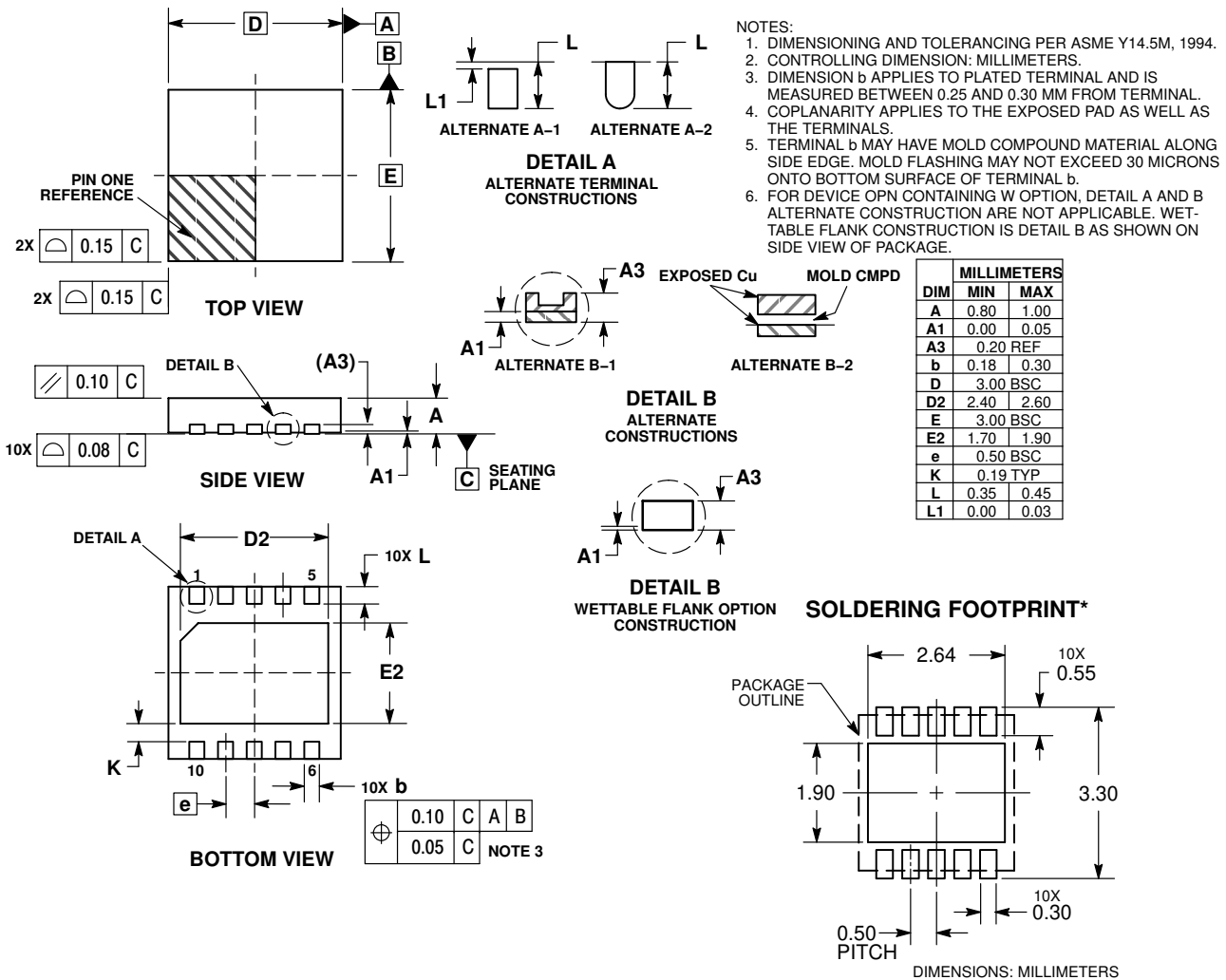

\*For additional information on our Pb-Free strategy and soldering details, please download the ON Semiconductor Soldering and Mounting Techniques Reference Manual, SOLDERRM/D.

All brand names and product names appearing in this document are registered trademarks or trademarks of their respective holders.

ON Semiconductor and are trademarks of Semiconductor Components Industries, LLC dba ON Semiconductor or its subsidiaries in the United States and/or other countries. ON Semiconductor owns the rights to a number of patents, trademarks, copyrights, trade secrets, and other intellectual property. A listing of ON Semiconductor's product/patent coverage may be accessed at [www.onsemi.com/site/pdf/Patent-Marking.pdf](http://www.onsemi.com/site/pdf/Patent-Marking.pdf). ON Semiconductor reserves the right to make changes without further notice to any products herein. ON Semiconductor makes no warranty, representation or guarantee regarding the suitability of its products for any particular purpose, nor does ON Semiconductor assume any liability arising out of the application or use of any product or circuit, and specifically disclaims any and all liability, including without limitation special, consequential or incidental damages. Buyer is responsible for its products and applications using ON Semiconductor products, including compliance with all laws, regulations and safety requirements or standards, regardless of any support or applications information provided by ON Semiconductor. "Typical" parameters which may be provided in ON Semiconductor data sheets and/or specifications can and do vary in different applications and actual performance may vary over time. All operating parameters, including "Typicals" must be validated for each customer application by customer's technical experts. ON Semiconductor does not convey any license under its patent rights nor the rights of others. ON Semiconductor products are not designed, intended, or authorized for use as a critical component in life support systems or any FDA Class 3 medical devices or medical devices with a same or similar classification in a foreign jurisdiction or any devices intended for implantation in the human body. Should Buyer purchase or use ON Semiconductor products for any such unintended or unauthorized application, Buyer shall indemnify and hold ON Semiconductor and its officers, employees, subsidiaries, affiliates, and distributors harmless against all claims, costs, damages, and expenses, and reasonable attorney fees arising out of, directly or indirectly, any claim of personal injury or death associated with such unintended or unauthorized use, even if such claim alleges that ON Semiconductor was negligent regarding the design or manufacture of the part. ON Semiconductor is an Equal Opportunity/Affirmative Action Employer. This literature is subject to all applicable copyright laws and is not for resale in any manner.

### PUBLICATION ORDERING INFORMATION

#### LITERATURE FULFILLMENT:

Literature Distribution Center for ON Semiconductor  
19521 E. 32nd Pkwy, Aurora, Colorado 80011 USA  
Phone: 303-675-2175 or 800-344-3860 Toll Free USA/Canada  
Fax: 303-675-2176 or 800-344-3867 Toll Free USA/Canada  
Email: [orderlit@onsemi.com](mailto:orderlit@onsemi.com)

**N. American Technical Support:** 800-282-9855 Toll Free  
USA/Canada  
**Europe, Middle East and Africa Technical Support:**  
Phone: 421 33 790 2910  
**Japan Customer Focus Center**  
Phone: 81-3-5817-1050

**ON Semiconductor Website:** [www.onsemi.com](http://www.onsemi.com)

**Order Literature:** <http://www.onsemi.com/orderlit>

For additional information, please contact your local Sales Representative