



Chipsmall Limited consists of a professional team with an average of over 10 year of expertise in the distribution of electronic components. Based in Hongkong, we have already established firm and mutual-benefit business relationships with customers from,Europe,America and south Asia,supplying obsolete and hard-to-find components to meet their specific needs.

With the principle of “Quality Parts,Customers Priority,Honest Operation,and Considerate Service”,our business mainly focus on the distribution of electronic components. Line cards we deal with include Microchip,ALPS,ROHM,Xilinx,Pulse,ON,Everlight and Freescale. Main products comprise IC,Modules,Potentiometer,IC Socket,Relay,Connector.Our parts cover such applications as commercial,industrial, and automotives areas.

We are looking forward to setting up business relationship with you and hope to provide you with the best service and solution. Let us make a better world for our industry!



Contact us

Tel: +86-755-8981 8866 Fax: +86-755-8427 6832

Email & Skype: info@chipsmall.com Web: www.chipsmall.com

Address: A1208, Overseas Decoration Building, #122 Zhenhua RD., Futian, Shenzhen, China





Test Procedure for the NCP1126DIPGEVB Evaluation Board

Introduction: The NCP1126 demo board is a universal input, off-line, constant voltage power supply for powering E-meters or white goods applications. The output can be configured easily with a few component changes for most typically used output voltages. The switching topology is a continuous conduction mode flyback converter utilizing the ON Semi NCP1126 co-packaged controller/MOSFET. The specific default demo board has an output rating of 5 volts at 4 amps max and a surge rating to 5 amps. Info for modification and testing for a 5Vout board is below.

Equipment Required:

1. Adjustable, isolated AC power source capable of zero to 265 Vac output up to 500 mA. AC source should have the capability of measuring output power in watts. If not, an AC line analyzer or AC wattmeter should be used. Wattmeter should be capable if reading down to 50 mW (for standby power measurements.)
2. Digital volt/amp meters to measure output current and voltage to the electronic load.
3. A variable electronic load or rheostat capable of up to a 7 amp load. If an electronic load is used it is preferable to have a constant resistance load mode. The current meter on the electronic load can be used in lieu of a series, in-line ammeter.
4. Oscilloscope with probe to monitor output ripple on the demo converter.

Setup Procedure: Set the equipment as shown in the diagram below so that the output voltage and current to the demo board can be measured and the output ripple can be monitored.

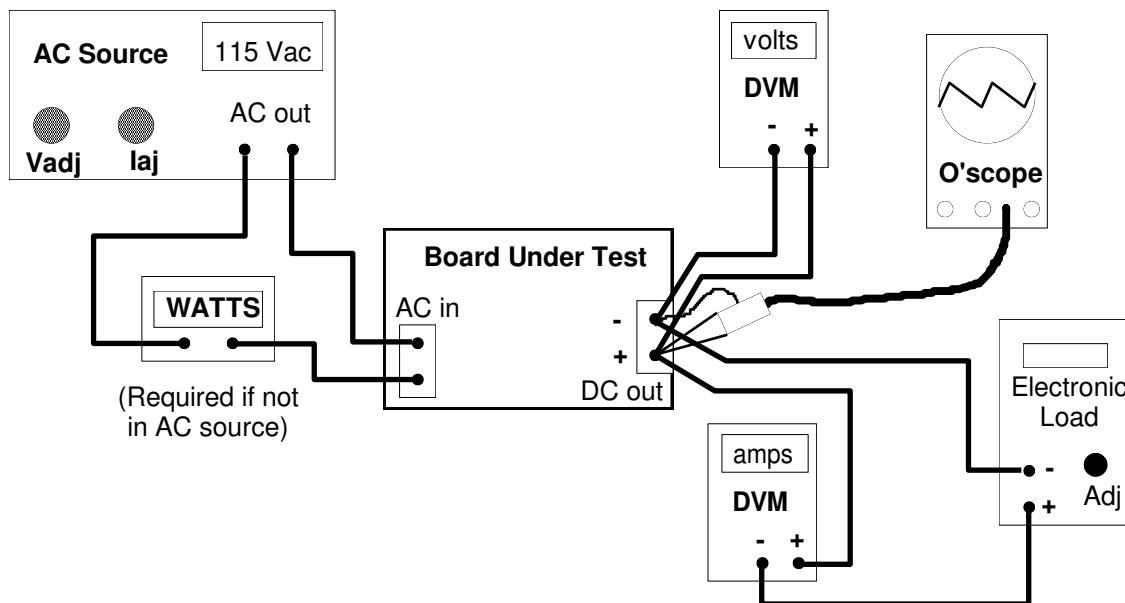

Test Procedure:

1. Switch the electronic load on and set to 10 mA load; switch all of the digital meters on (assuming they are wired properly for voltage and current sensing); turn the oscilloscope on with sensing in AC mode and 100 mV per division vertical and a sweep rate of 5 uS per division. Connect the scope probe to the demo board's output terminals.
2. With the AC source OFF, set the current limit on the AC source to 400 mA and the output voltage to 120 Vac.
3. Turn on the AC source and the power supply output voltage should be 5.00 Vdc \pm 0.2 V on the DVM.
4. Adjust the electronic load from no load slowly up to 3.0A (full load). The output voltage should remain within 120 mV (1%) of nominal if properly regulating. The output ripple (switching frequency) on the oscilloscope should be less than 150 mV peak-to-peak at full load. (Note – scope probe tip should be decoupled with a 0.1uF ceramic capacitor and ground wire should not be used to get best accuracy and max attenuation of switching noise pickup.)
5. Adjust the AC source down to 90 Vac and the power supply output should still be in spec. Return the AC source to 120 Vac.
6. Set the output load to 2.5A, check the efficiency. $\text{Effic} = (\text{Vout} \times \text{Iout})/\text{Pin}$. It should be greater than 79%.
7. Continue to increase the load slowly and the over-current protection should kick in between 4~5A. This should result in a “hick-up” start-stop type of operation.
8. Set the load back to 3.0A and the power supply should recover with proper output voltage.
9. Adjust the electronic load to back to zero, switch the load off, and check the input power (standby power). It should be below 100mW.
10. Adjust the AC input to 230 Vac and repeat tests (3) through (8) with the exception of (5).
11. Switch the AC source off and disconnect the demo board.

End of Test.

Parts Change for 12Vout Version (See BOM) from 5V Board:

Vout set: R14 to 1K ohms; R1 to 39K

Output Capacitors: C9A/B to 1000 uF, 16V

Transformer: T1 to ICE Components # TO12157