



Chipsmall Limited consists of a professional team with an average of over 10 year of expertise in the distribution of electronic components. Based in Hongkong, we have already established firm and mutual-benefit business relationships with customers from,Europe,America and south Asia,supplying obsolete and hard-to-find components to meet their specific needs.

With the principle of “Quality Parts,Customers Priority,Honest Operation,and Considerate Service”,our business mainly focus on the distribution of electronic components. Line cards we deal with include Microchip,ALPS,ROHM,Xilinx,Pulse,ON,Everlight and Freescale. Main products comprise IC,Modules,Potentiometer,IC Socket,Relay,Connector.Our parts cover such applications as commercial,industrial, and automotives areas.

We are looking forward to setting up business relationship with you and hope to provide you with the best service and solution. Let us make a better world for our industry!



Contact us

Tel: +86-755-8981 8866 Fax: +86-755-8427 6832

Email & Skype: info@chipsmall.com Web: www.chipsmall.com

Address: A1208, Overseas Decoration Building, #122 Zhenhua RD., Futian, Shenzhen, China



NCP1207

PWM Current-Mode Controller for Free Running Quasi-Resonant Operation

The NCP1207 combines a true current mode modulator and a demagnetization detector to ensure full borderline/critical Conduction Mode in any load/line conditions and minimum drain voltage switching (Quasi-Resonant operation). Due to its inherent skip cycle capability, the controller enters burst mode as soon as the power demand falls below a predetermined level. As this happens at low peak current, no audible noise can be heard. An internal 8.0 μ s timer prevents the free-run frequency to exceed 100 kHz (therefore below the 150 kHz CISPR-22 EMI starting limit), while the skip adjustment capability lets the user select the frequency at which the burst foldback takes place.

The Dynamic Self-Supply (DSS) drastically simplifies the transformer design in avoiding the use of an auxiliary winding to supply the NCP1207. This feature is particularly useful in applications where the output voltage varies during operation (e.g. battery chargers). Due to its high-voltage technology, the IC is directly connected to the high-voltage DC rail. As a result, the short-circuit trip point is not dependent upon any V_{CC} auxiliary level.

The transformer core reset detection is done through an auxiliary winding which, brought via a dedicated pin, also enables fast Overvoltage Protection (OVP). Once an OVP has been detected, the IC permanently latches off.

Finally, the continuous feedback signal monitoring implemented with an Overcurrent Fault Protection (OCP) circuitry makes the final design rugged and reliable.

Features

- Pb-Free Packages are Available*
- Free-Running Borderline/Critical Mode Quasi-Resonant Operation
- Current-Mode with Adjustable Skip-Cycle Capability
- No Auxiliary Winding V_{CC} Operation
- Auto-Recovery Overcurrent Protection
- Latching Overvoltage Protection
- External Latch Triggering, e.g. Via Overtemperature Signal
- 500 mA Peak Current Source/Sink Capability
- Internal 1.0 ms Soft-Start
- Internal 8.0 μ s Minimum T_{OFF}
- Adjustable Skip Level
- Internal Temperature Shutdown
- Direct Optocoupler Connection
- SPICE Models Available for TRANsient Analysis

Typical Applications

- AC-DC Adapters for Notebooks, etc.
- Offline Battery Chargers
- Consumer Electronics (DVD Players, Set-Top Boxes, TVs, etc.)
- Auxiliary Power Supplies (USB, Appliances, TVs, etc.)

*For additional information on our Pb-Free strategy and soldering details, please download the ON Semiconductor Soldering and Mounting Techniques Reference Manual, SOLDERRM/D.



ON Semiconductor®

<http://onsemi.com>

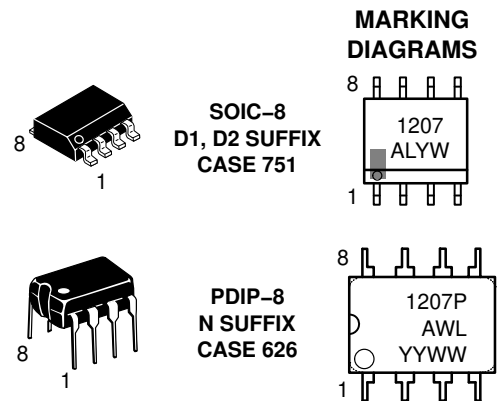

1207/P = Device Code
 A = Assembly Location
 WL, L = Wafer Lot
 YY, Y = Year
 WW, W = Work Week

PIN CONNECTIONS

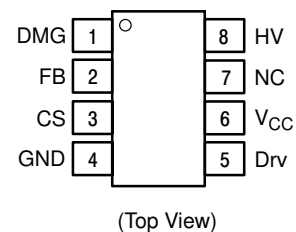

ORDERING INFORMATION

| Device | Package | Shipping† |
|-------------|---------------------|------------------|
| NCP1207DR2 | SOIC-8 | 2500/Tape & Reel |
| NCP1207DR2G | SOIC-8 (Pb-Free) | 2500/Tape & Reel |
| NCP1207P | PDIP-8 | 50 Units/Tube |
| NCP1207PG | PDIP-8 (Pb-Free) | 50 Units/Tube |

†For information on tape and reel specifications, including part orientation and tape sizes, please refer to our Tape and Reel Packaging Specifications Brochure, BRD8011/D.

NCP1207

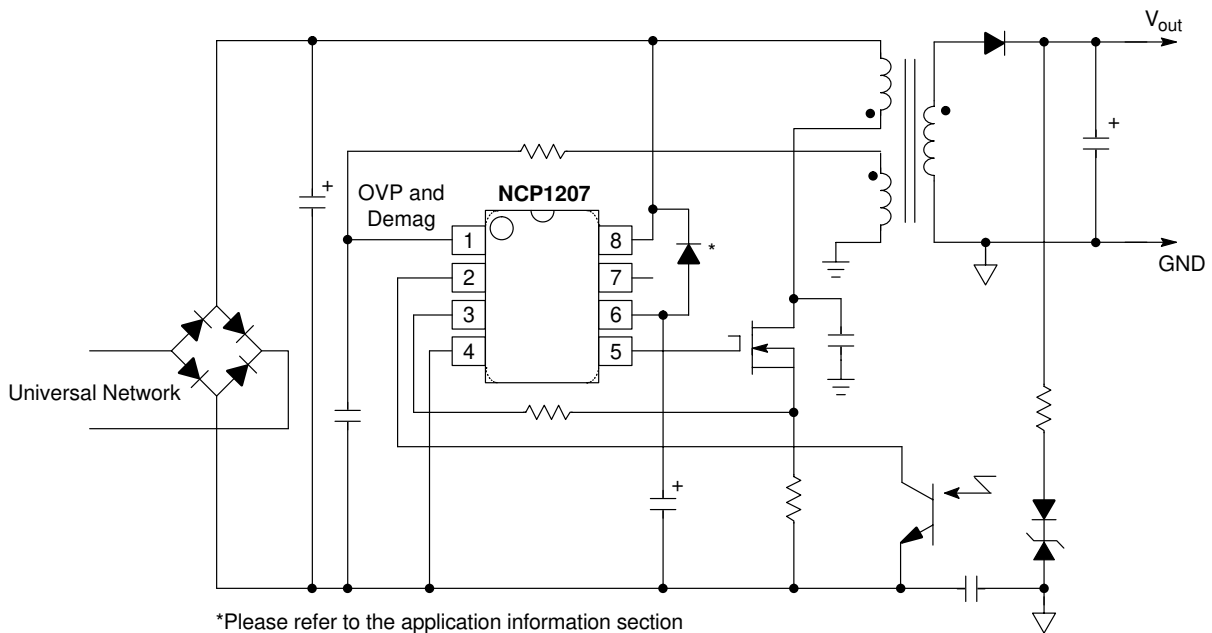

Figure 1. Typical Application

PIN FUNCTION DESCRIPTION

| Pin No. | Pin Name | Function | Description |
|---------|-----------------|--|---|
| 1 | Demag | Core reset detection and OVP | The auxiliary FLYBACK signal ensures discontinuous operation and offers a fixed overvoltage detection level of 7.2 V. |
| 2 | FB | Sets the peak current setpoint | By connecting an Optocoupler to this pin, the peak current setpoint is adjusted accordingly to the output power demand. By bringing this pin below the internal skip level, device shuts off. |
| 3 | CS | Current sense input and skip cycle level selection | This pin senses the primary current and routes it to the internal comparator via an L.E.B. By inserting a resistor in series with the pin, you control the level at which the skip operation takes place. |
| 4 | GND | The IC ground | - |
| 5 | Drv | Driving pulses | The driver's output to an external MOSFET. |
| 6 | V _{CC} | Supplies the IC | This pin is connected to an external bulk capacitor of typically 10 μF. |
| 7 | NC | - | This unconnected pin ensures adequate creepage distance. |
| 8 | HV | High-voltage pin | Connected to the high-voltage rail, this pin injects a constant current into the V _{CC} bulk capacitor. |

NCP1207

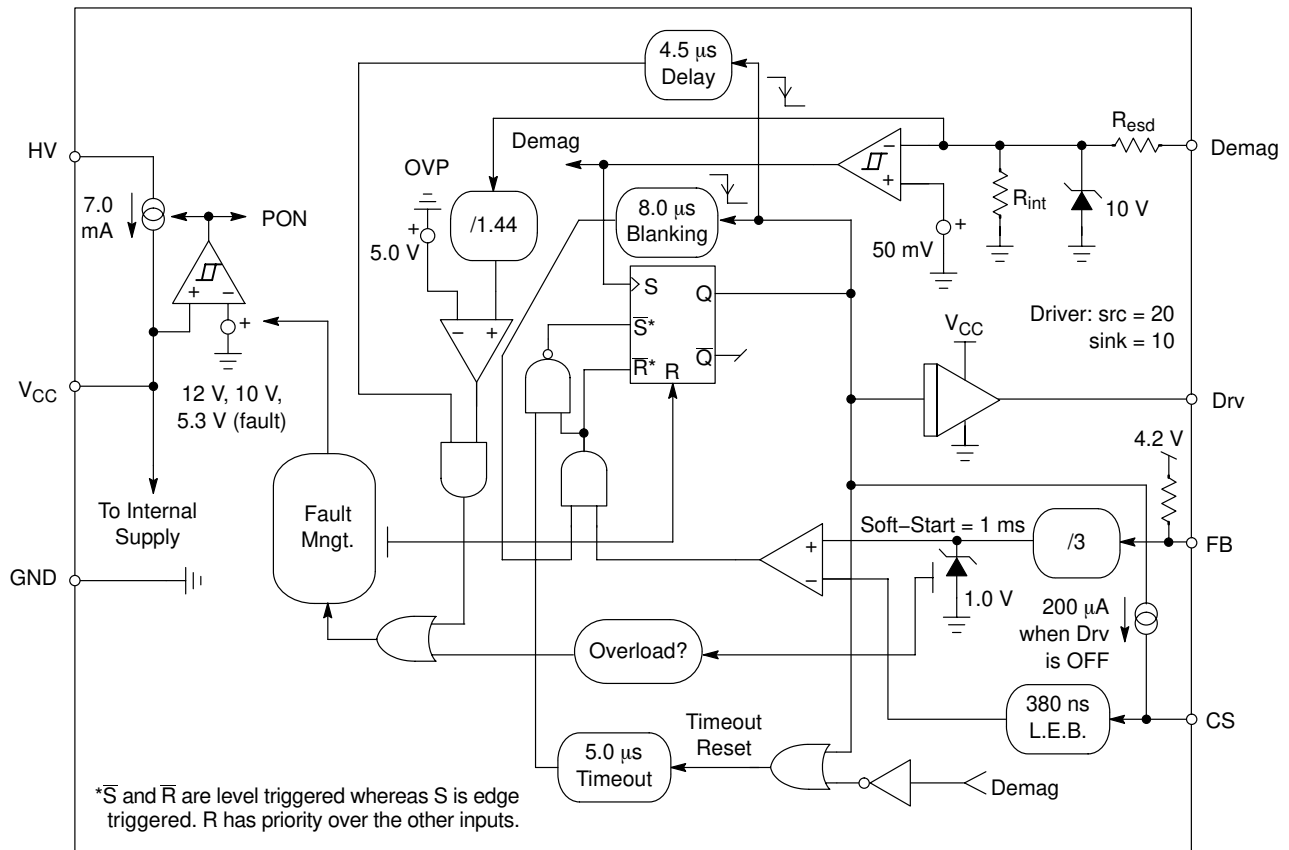

Figure 2. Internal Circuit Architecture

MAXIMUM RATINGS

| Rating | Symbol | Value | Units |
|--|-----------------|-------------|-------|
| Power Supply Voltage | V_{CC}, Drv | 16 | V |
| Maximum Voltage on all other pins except Pin 8 (HV), Pin 6 (V_{CC}) Pin 5 (Drv) and Pin 1 (Demag) | – | –0.3 to 10 | V |
| Maximum Current into all pins except V_{CC} (6), HV (8) and Demag (1) when 10 V ESD diodes are activated | – | 5.0 | mA |
| Maximum Current in Pin 1 | I_{dem} | +3.0/–2.0 | mA |
| Thermal Resistance, Junction-to-Case | $R_{\theta JC}$ | 57 | °C/W |
| Thermal Resistance, Junction-to-Air, SOIC version | $R_{\theta JA}$ | 178 | °C/W |
| Thermal Resistance, Junction-to-Air, PDIP version | $R_{\theta JA}$ | 100 | °C/W |
| Operating Junction Temperature | T_J | –40 to +125 | °C |
| Maximum Junction Temperature | T_{JMAX} | 150 | °C |
| Temperature Shutdown | – | 155 | °C |
| Hysteresis in Shutdown | – | 30 | °C |
| Storage Temperature Range | – | –60 to +150 | °C |
| ESD Capability, HBM Model (All pins except HV) | – | 2.0 | kV |
| ESD Capability, Machine Model | – | 200 | V |
| Maximum Voltage on Pin 8 (HV), Pin 6 (V_{CC}) decoupled to ground with 10 μ F | V_{HVMAX} | 500 | V |
| Minimum Voltage on Pin 8 (HV), Pin 6 (V_{CC}) decoupled to ground with 10 μ F | V_{HVMIN} | 40 | V |

Maximum ratings are those values beyond which device damage can occur. Maximum ratings applied to the device are individual stress limit values (not normal operating conditions) and are not valid simultaneously. If these limits are exceeded, device functional operation is not implied, damage may occur and reliability may be affected.

NCP1207

ELECTRICAL CHARACTERISTICS (For typical values $T_J = 25^\circ\text{C}$, for min/max values $T_J = 0^\circ\text{C}$ to $+125^\circ\text{C}$, Max $T_J = 150^\circ\text{C}$, $V_{CC} = 11\text{ V}$ unless otherwise noted)

| Rating | Pin | Symbol | Min | Typ | Max | Unit |
|--------|-----|--------|-----|-----|-----|------|
|--------|-----|--------|-----|-----|-----|------|

DYNAMIC SELF-SUPPLY

| | | | | | | |
|--|---|----------------------|------|-----|-----------------|---------------|
| V_{CC} Increasing Level at which the Current Source Turns-off | 6 | $V_{CC\text{OFF}}$ | 10.8 | 12 | 12.9 | V |
| V_{CC} Decreasing Level at which the Current Source Turns-on | 6 | $V_{CC\text{ON}}$ | 9.1 | 10 | 10.6 | V |
| V_{CC} Decreasing Level at which the Latchoff Phase Ends | 6 | $V_{CC\text{latch}}$ | – | 5.3 | – | V |
| Internal IC Consumption, No Output Load on Pin 5, $F_{\text{SW}} = 60\text{ kHz}$ | 6 | I_{CC1} | – | 1.0 | 1.3 (Note 1) | mA |
| Internal IC Consumption, 1.0 nF Output Load on Pin 5, $F_{\text{SW}} = 60\text{ kHz}$ | 6 | I_{CC2} | – | 1.6 | 2.0 (Note 1) | mA |
| Internal IC Consumption in Latchoff Phase | 6 | I_{CC3} | – | 330 | – | μA |

INTERNAL STARTUP CURRENT SOURCE ($T_J > 0^\circ\text{C}$)

| | | | | | | |
|---|---|-----------------|-----|-----|-----|----|
| High-voltage Current Source, $V_{CC} = 10\text{ V}$ | 8 | I_{C1} | 4.3 | 7.0 | 9.6 | mA |
| High-voltage Current Source, $V_{CC} = 0$ | 8 | I_{C2} | – | 8.0 | – | mA |

DRIVE OUTPUT

| | | | | | | |
|---|---|-----------------|-----|----|----|----------|
| Output Voltage Rise-time @ $CL = 1.0\text{ nF}$, 10–90% of Output Signal | 5 | T_r | – | 40 | – | ns |
| Output Voltage Fall-time @ $CL = 1.0\text{ nF}$, 10–90% of Output Signal | 5 | T_f | – | 20 | – | ns |
| Source Resistance | 5 | R_{OH} | 12 | 20 | 36 | Ω |
| Sink Resistance | 5 | R_{OL} | 5.0 | 10 | 19 | Ω |

CURRENT COMPARATOR (Pin 5 Unloaded)

| | | | | | | |
|--|---|--------------------|------|------|------|---------------|
| Input Bias Current @ 1.0 V Input Level on Pin 3 | 3 | I_{IB} | – | 0.02 | – | μA |
| Maximum Internal Current Setpoint | 3 | I_{Limit} | 0.92 | 1.0 | 1.12 | V |
| Propagation Delay from Current Detection to Gate OFF State | 3 | T_{DEL} | – | 100 | 160 | ns |
| Leading Edge Blanking Duration | 3 | T_{LEB} | – | 380 | – | ns |
| Internal Current Offset Injected on the CS Pin during OFF Time | 3 | I_{skip} | – | 200 | – | μA |

OVERVOLTAGE SECTION ($V_{CC} = 11\text{ V}$)

| | | | | | | |
|------------------------------|---|---------------------|-----|-----|-----|---------------|
| Sampling Delay after ON Time | 1 | T_{sample} | – | 4.5 | – | μs |
| OVP Internal Reference Level | 1 | V_{ref} | 6.4 | 7.2 | 8.0 | V |

FEEDBACK SECTION ($V_{CC} = 11\text{ V}$, Pin 5 Loaded by 1.0 k Ω)

| | | | | | | |
|--|---|--------------------|---|-----|---|------------|
| Internal Pullup Resistor | 2 | R_{up} | – | 20 | – | k Ω |
| Pin 3 to Current Setpoint Division Ratio | – | I_{ratio} | – | 3.3 | – | – |
| Internal Soft-Start | – | T_{ss} | – | 1.0 | – | ms |

DEMAGNETIZATION DETECTION BLOCK

| | | | | | | |
|---|--------|------------------------------------|-------------|------------|------------|---------------|
| Input Threshold Voltage (V_{pin1} Decreasing) | 1 | V_{TH} | 35 | 50 | 90 | mV |
| Hysteresis (V_{pin1} Decreasing) | 1 | V_{H} | – | 20 | – | mV |
| Input Clamp Voltage High State ($I_{\text{pin1}} = 3.0\text{ mA}$) Low State ($I_{\text{pin1}} = -2.0\text{ mA}$) | 1 1 | V_{CH} V_{CL} | 8.0 –0.9 | 10 –0.7 | 12 –0.5 | V V |
| Demag Propagation Delay | 1 | T_{dem} | – | 210 | – | ns |
| Internal Input Capacitance at $V_{\text{pin1}} = 1.0\text{ V}$ | 1 | C_{par} | – | 10 | – | pF |
| Minimum T_{OFF} (Internal Blanking Delay after T_{ON}) | 1 | T_{blank} | – | 8.0 | – | μs |
| Timeout After Last Demag Transition | 1 | T_{out} | – | 5.0 | – | μs |
| Pin 1 Internal Impedance | 1 | R_{int} | – | 28 | – | k Ω |

1. Max value at $T_J = 0^\circ\text{C}$.

NCP1207

TYPICAL CHARACTERISTICS

($T_J = -40^{\circ}\text{C}$ to 125°C)

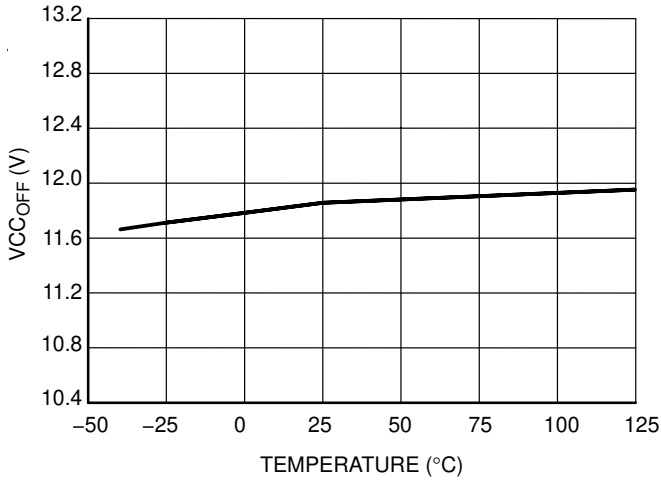

Figure 3. V_{CC} Increasing Level at which the Current Source Turns-off versus Temperature

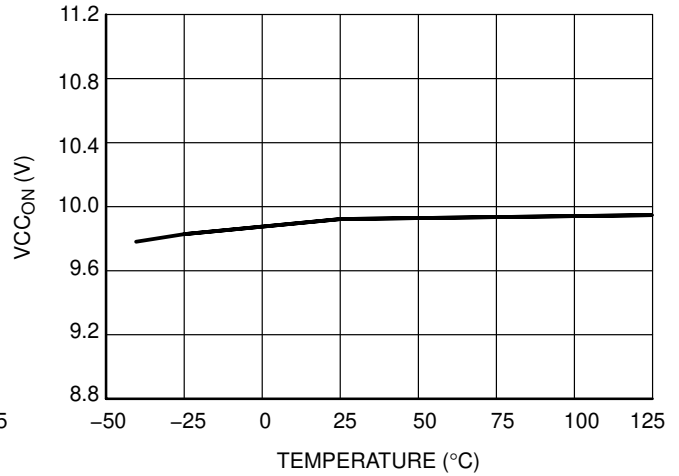

Figure 4. V_{CC} Decreasing Level at which the Current Source Turns-on versus Temperature

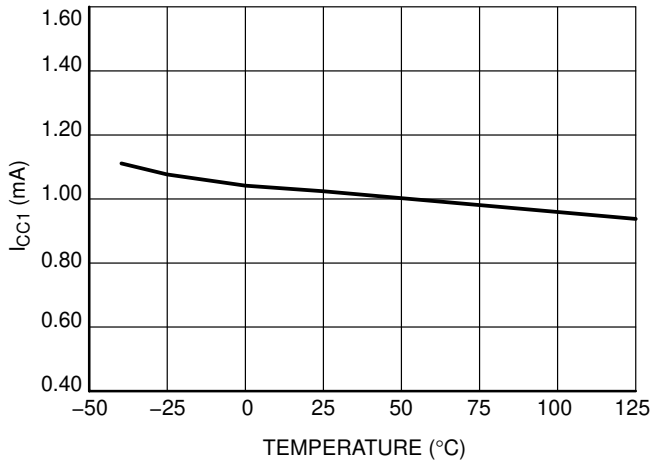

Figure 5. Internal IC Consumption, No Output Load on Pin 5 versus Temperature

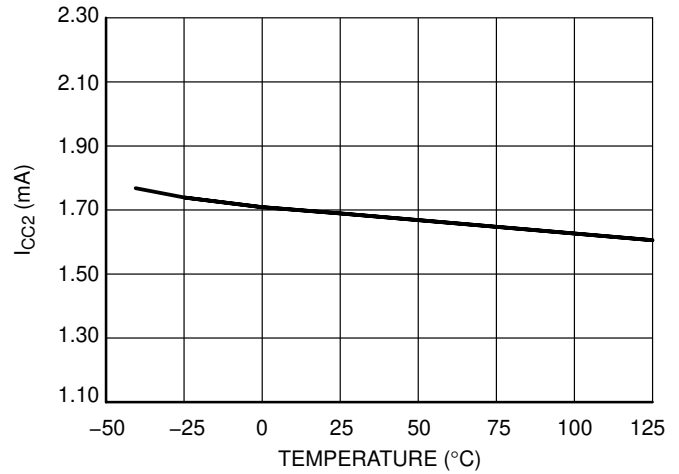

Figure 6. Internal IC Consumption, Output Load on Pin 5 versus Temperature

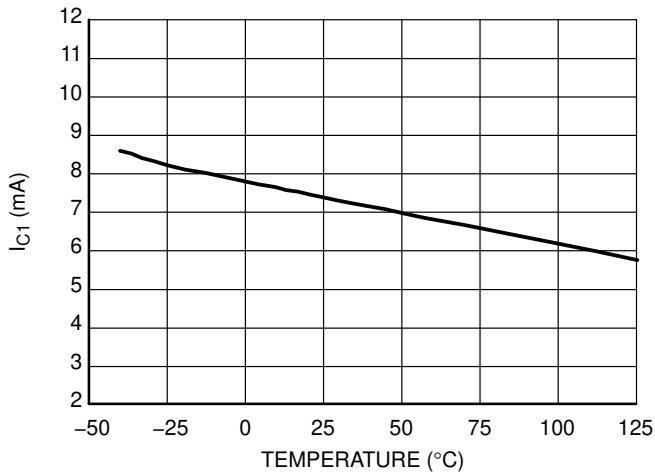

Figure 7. Internal Startup Current Source, $V_{CC} = 10\text{ V}$ versus Temperature

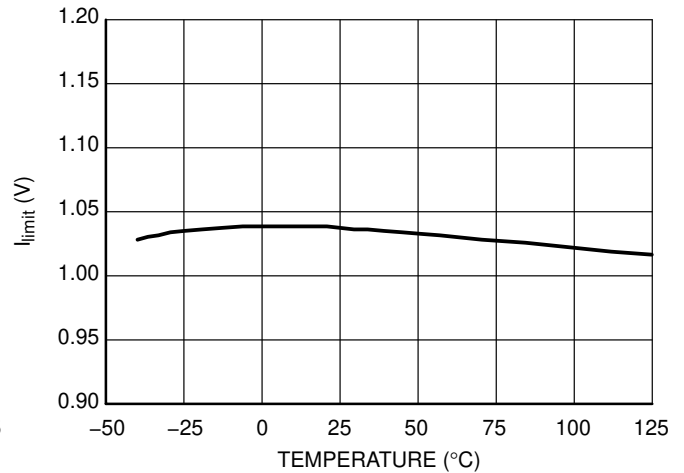

Figure 8. Maximum Internal Current Setpoint versus Temperature

NCP1207

TYPICAL CHARACTERISTICS

($T_J = -40^{\circ}\text{C}$ to 125°C)

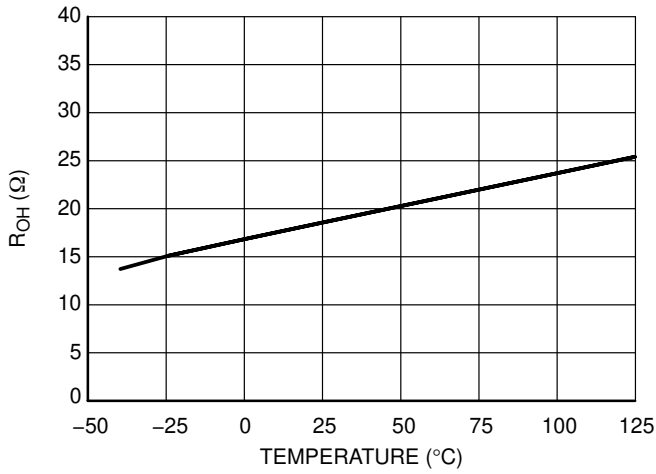

Figure 9. Source Resistance versus Temperature

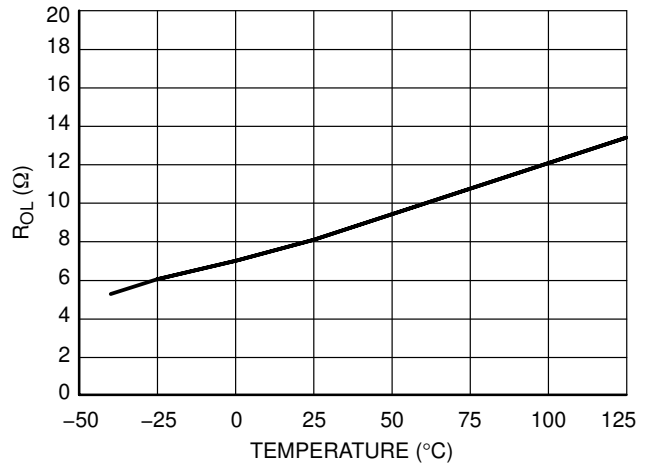

Figure 10. Sink Resistance versus Temperature

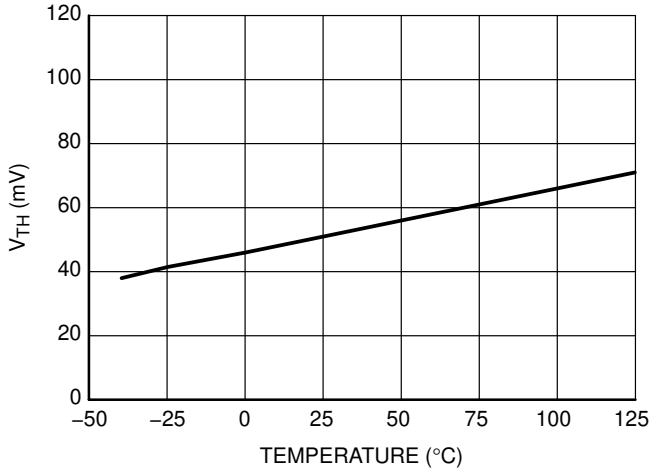

Figure 11. Input Voltage (V_{pin1} Decreasing) versus Temperature

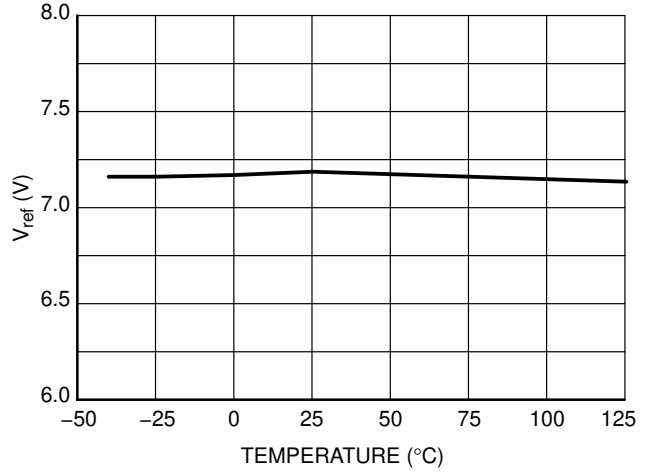

Figure 12. OVP Internal Reference Level versus Temperature

NCP1207

TYPICAL CHARACTERISTICS

($T_J = -50^{\circ}\text{C}$ to 125°C)

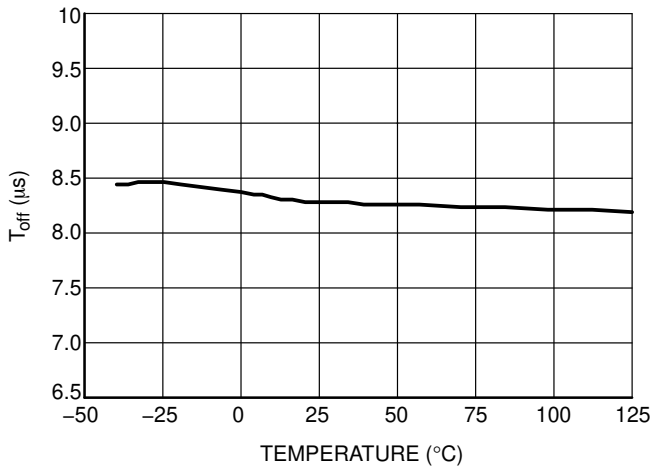

Figure 13. Minimum T_{off} versus Temperature

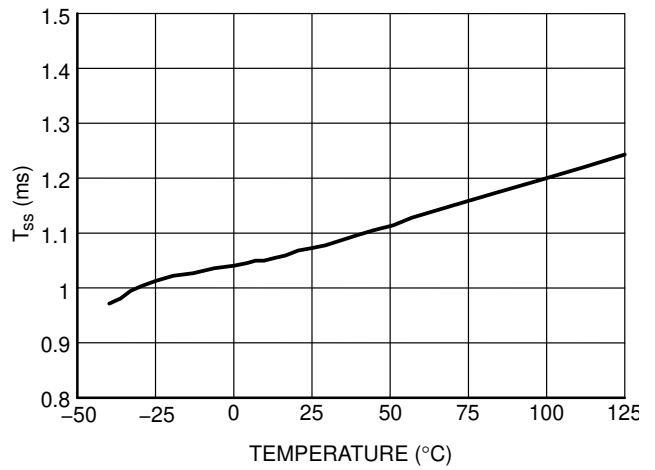

Figure 14. Internal Soft-Start versus Temperature

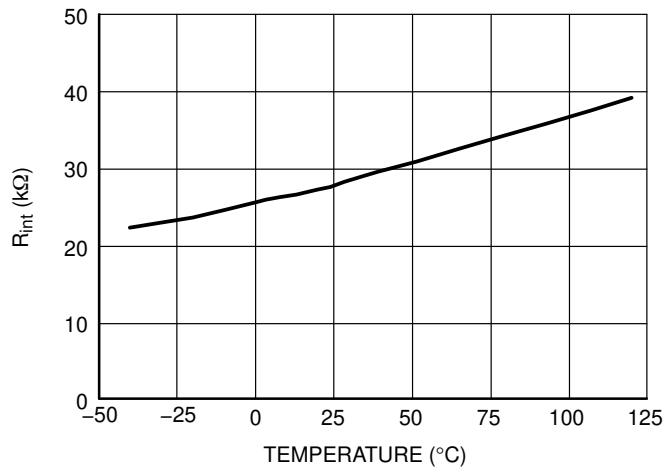

Figure 15. DMG Pin Internal Resistance versus Temperature

Application Information

Introduction

The NCP1207 implements a standard current mode architecture where the switch-off time is dictated by the peak current setpoint whereas the core reset detection triggers the turn-on event. This component represents the ideal candidate where low part-count is the key parameter, particularly in low-cost AC-DC adapters, consumer electronics, auxiliary supplies, etc. Thanks to its high-performance High-Voltage technology, the NCP1207 incorporates all the necessary components / features needed to build a rugged and reliable Switchmode Power Supply (SMPS):

- **Transformer core reset detection:** borderline / critical operation is ensured whatever the operating conditions are. As a result, there are virtually no primary switch turn-on losses and no secondary diode recovery losses. The converter also stays a first-order system and accordingly eases the feedback loop design.
- **Quasi-resonant operation:** by delaying the turn-on event, it is possible to restart the MOSFET in the minimum of the drain-source wave, ensuring reduced EMI / video noise perturbations. In nominal power conditions, the NCP1207 operates in Borderline Conduction Mode (BCM) also called Critical Conduction Mode.
- **Dynamic Self-Supply (DSS):** due to its Very High Voltage Integrated Circuit (VHVIC) technology, ON Semiconductor's NCP1207 allows for a direct pin connection to the high-voltage DC rail. A dynamic current source charges up a capacitor and thus provides a fully independent V_{CC} level to the NCP1207. As a result, there is no need for an auxiliary winding whose management is always a problem in variable output voltage designs (e.g. battery chargers).
- **Overvoltage Protection (OVP):** by sampling the plateau voltage on the demagnetization winding, the NCP1207 goes into latched fault condition whenever an overvoltage condition is detected. The controller stays fully latched in this position until the V_{CC} is cycled down 4.0 V, e.g. when the user un-plugs the power supply from the mains outlet and re-plugs it.
- **External latch trip point:** by externally forcing a level on the OVP greater than the internal setpoint, it is possible to latch off the IC, e.g. with a signal coming from a temperature sensor.
- **Adjustable skip cycle level:** by offering the ability to tailor the level at which the skip cycle takes place, the designer can make sure that the skip operation only

occurs at low peak current. This point guarantees a noise-free operation with cheap transformer. This option also offers the ability to fix the maximum switching frequency when entering light load conditions.

- **Overcurrent Protection (OCP):** by continuously monitoring the FB line activity, NCP1207 enters burst mode as soon as the power supply undergoes an overload. The device enters a safe low power operation which prevents from any lethal thermal runaway. As soon as the default disappears, the power supply resumes operation. Unlike other controllers, overload detection is performed independently of any auxiliary winding level. In presence of a bad coupling between both power and auxiliary windings, the short circuit detection can be severely affected. The DSS naturally shields you against these troubles.

Dynamic Self-Supply

The DSS principle is based on the charge/discharge of the V_{CC} bulk capacitor from a low level up to a higher level. We can easily describe the current source operation with some simple logical equations:

POWER-ON: IF $V_{CC} < V_{CCOFF}$ THEN Current Source is ON, no output pulses

IF V_{CC} decreasing $> V_{CCON}$ THEN Current Source is OFF, output is pulsing

IF V_{CC} increasing $< V_{CCOFF}$ THEN Current Source is ON, output is pulsing

Typical values are: $V_{CCOFF} = 12\text{ V}$, $V_{CCON} = 10\text{ V}$

To better understand the operational principle, Figure 16's sketch offers the necessary light.

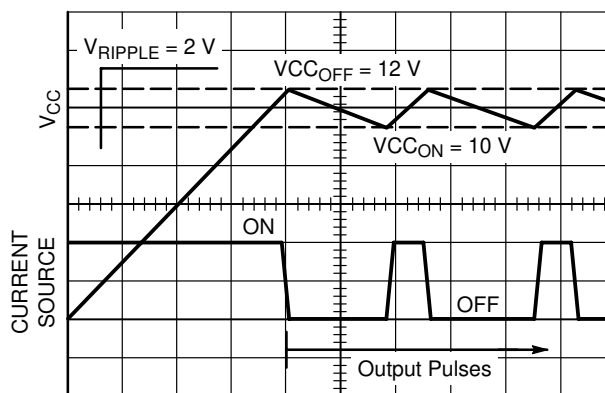

Figure 16. The Charge/Discharge Cycle Over a $10\ \mu\text{F}$ V_{CC} Capacitor

The DSS behavior actually depends on the internal IC consumption and the MOSFET’s gate charge Qg. If we select a MOSFET like the MTP2N60E, Qg equals 22 nC (max). With a maximum switching frequency selected at 75 kHz, the average power necessary to drive the MOSFET (excluding the driver efficiency and neglecting various voltage drops) is:

$F_{sw} \cdot Q_g \cdot V_{CC}$ with:

F_{sw} = maximum switching frequency

Q_g = MOSFET’s gate charge

V_{CC} = V_{GS} level applied to the gate

To obtain the output current, simply divide this result by V_{CC} : $I_{driver} = F_{SW} \cdot Q_g = 1.6$ mA. The total standby power consumption at no-load will therefore heavily rely on the internal IC consumption plus the above driving current (altered by the driver’s efficiency). Suppose that the IC is supplied from a 350 VDC line. The current flowing through pin 8 is a direct image of the NCP1207 consumption (neglecting the switching losses of the HV current source). If I_{CC2} equals 2.3 mA @ $T_j = 60^\circ\text{C}$, then the power dissipated (lost) by the IC is simply: $350\text{ V} \times 2.3\text{ mA} = 805\text{ mW}$. For design and reliability reasons, it would be interested to reduce this source of wasted power that increase the die temperature. This can be achieved by using different methods:

1. Use a MOSFET with lower gate charge Qg.
2. Connect pin 8 through a diode (1N4007 typically) to one of the mains input. The average value on pin 8 becomes $\frac{V_{mainsPEAK} \cdot 2}{\pi}$. Our power contribution example drops to: $223\text{ V} \times 2.3\text{ mA} = 512\text{ mW}$. If a resistor is installed between the mains and the diode, you further force the dissipation to migrate from the package to the resistor. The resistor value should account for low-line startups.

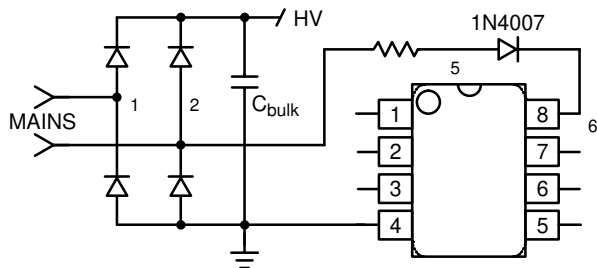

Figure 17. A simple diode naturally reduces the average voltage on pin 8

When using Figure 17 option, it is important to check the absence of any negative ringing that could occur on pin 8. The resistor in series should help to damp any parasitic LC network that would ring when suddenly applying the power to the IC. Also, since the power disappears during 10 ms (half-wave rectification), C_{VCC} should be calculated to supply the IC during these holes in the supply

3. Permanently force the V_{CC} level above V_{CCH} with an auxiliary winding. It will automatically disconnect the internal startup source and the IC will be fully self-supplied from this winding. Again, the total power drawn from the mains will significantly decrease. Make sure the auxiliary voltage never exceeds the 16 V limit.

Skipping Cycle Mode

The NCP1207 automatically skips switching cycles when the output power demand drops below a given level. This is accomplished by monitoring the FB pin. In normal operation, pin 2 imposes a peak current accordingly to the load value. If the load demand decreases, the internal loop asks for less peak current. When this setpoint reaches a determined level, the IC prevents the current from decreasing further down and starts to blank the output pulses: the IC enters the so-called skip cycle mode, also named controlled burst operation. The power transfer now depends upon the width of the pulse bunches (Figure 18) and follows the following formula:

$\frac{1}{2} \cdot L_p \cdot I_p^2 \cdot F_{sw} \cdot D_{burst}$ with:

L_p = primary inductance

F_{sw} = switching frequency within the burst

I_p = peak current at which skip cycle occurs

D_{burst} = burst width / burst recurrence

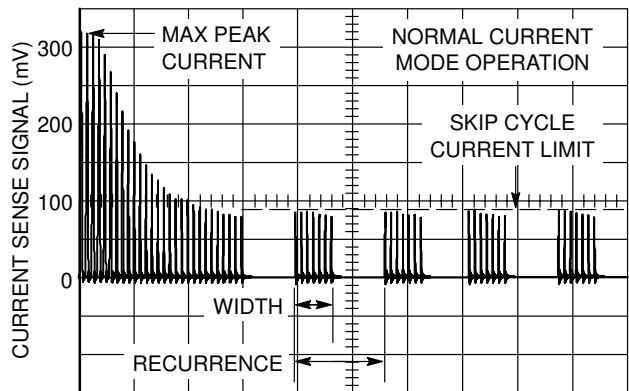

Figure 18. The skip cycle takes place at low peak currents which guaranties noise free operation

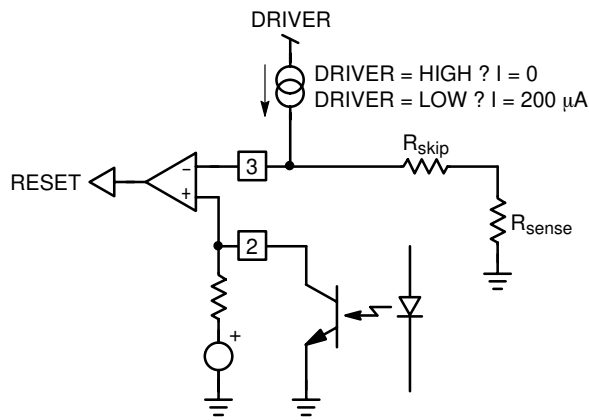

Figure 19. A patented method allows for skip level selection via a series resistor inserted in series with the current

The skip level selection is done through a simple resistor inserted between the current sense input and the sense element. Every time the NCP1207 output driver goes low, a 200 μA source forces a current to flow through the sense pin (Figure 19): when the driver is high, the current source is off and the current sense information is normally processed. As soon as the driver goes low, the current source delivers 200 μA and develops a ground referenced voltage across R_{skip} . If this voltage is below the feedback voltage, the current sense comparator stays in the high state and the internal latch can be triggered by the next clock cycle. Now, if because of a low load mode the feedback voltage is below R_{skip} level, then the

current sense comparator permanently resets the latch and the next clock cycle (given by the demagnetization detection) is ignored: we are skipping cycles as shown by Figure 20. As soon as the feedback voltage goes up again, there can be two situations: the recurrent period is small and a new demagnetization detection (next wave) signal triggers the NCP1207. To the opposite, in low output power conditions, no more ringing waves are present on the drain and the toggling of the current sense comparator together with the internal 5 μs timeout initiates a new cycle start. In normal operating conditions, e.g. when the drain oscillations are generous, the demagnetization comparator can detect the 50 mV crossing and gives the “green light”, alone, to re-activate the power switch. However, when skip cycle takes place (e.g. at low output power demands), the restart event slides along the drain ringing waveforms (actually the valley locations) which decays more or less quickly, depending on the $L_{\text{primary}}-C_{\text{parasitic}}$ network damping factor. The situation can thus quickly occur where the ringing becomes too weak to be detected by the demagnetization comparator: it then permanently stays locked in a given position and can no longer deliver the “green light” to the controller. To help in this situation, the NCP1207 implements a 5 μs timeout generator: each time the 50 mV crossing occurs, the timeout is reset. So, as long as the ringing becomes too low, the timeout generator starts to count and after 5 μs , it delivers its “green light”. If the skip signal is already present then the controller restarts; otherwise the logic waits for it to set the drive output high. Figure 20 depicts these two different situations:

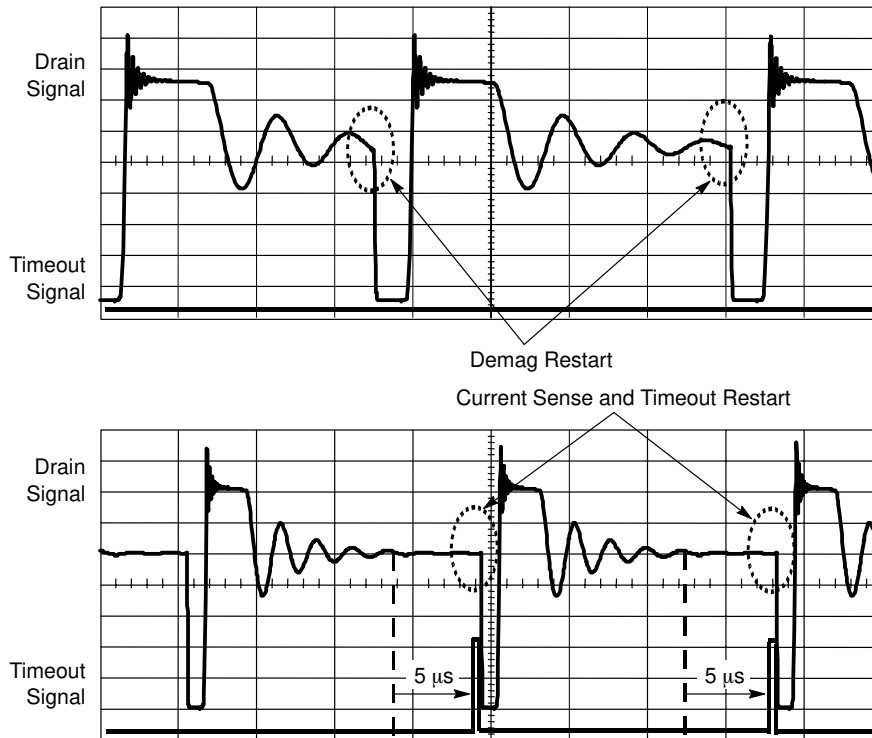

Figure 20. When the primary natural ringing becomes too low, the internal timeout together with the sense comparator initiates a new cycle when FB passes the skip level.

Demagnetization Detection

The core reset detection is done by monitoring the voltage activity on the auxiliary winding. This voltage features a FLYBACK polarity. The typical detection level is fixed at 50 mV as exemplified by Figure 21.

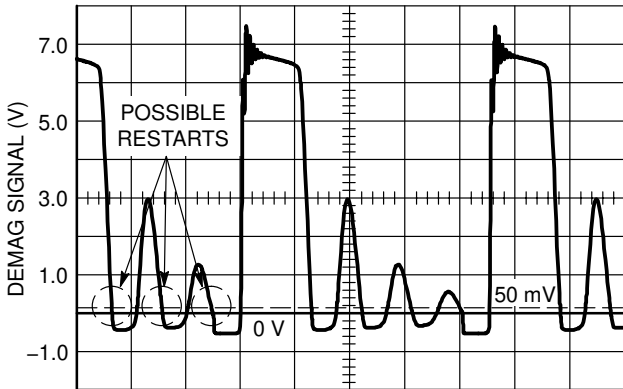

Figure 21. Core reset detection is done through a dedicated auxiliary winding monitoring

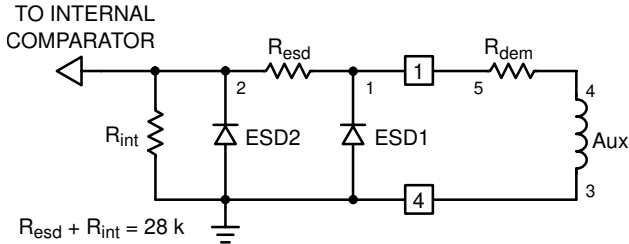

Figure 22. Internal Pad Implementation

An internal timer prevents any restart within 8.0 μ s further to the driver going-low transition. This prevents the switching frequency to exceed $(1 / (T_{ON} + 8.0 \mu s))$ but also avoid false leakage inductance tripping at turn-off. In some cases, the leakage inductance kick is so energetic, that a slight filtering is necessary.

The 1207 demagnetization detection pad features a specific component arrangement as detailed by Figure 22. In this picture, the zener diodes network protect the IC against any potential ESD discharge that could appear on the pins. The first ESD diode connected to the pad, exhibits a parasitic capacitance. When this parasitic capacitance (10 pF typically) is combined with R_{dem} , a restart delay is created and the possibility to switch right in the drain-source wave exists. This guarantees QR operation with all the associated benefits (low EMI, no turn-on losses etc.). R_{dem} should be calculated to limit the maximum current flowing through pin 1 to less than +3 mA/-2 mA. If during turn-on, the auxiliary winding delivers 30 V (at the highest line level), then the minimum R_{dem} value is defined by:

$$(30 \text{ V} + 0.7 \text{ V}) / 2 \text{ mA} = 14.6 \text{ k}\Omega$$

This value will be further increased to introduce a restart delay and also a slight filtering in case of high leakage energy.

Figure 23 portrays a typical V_{DS} shot at nominal output power.

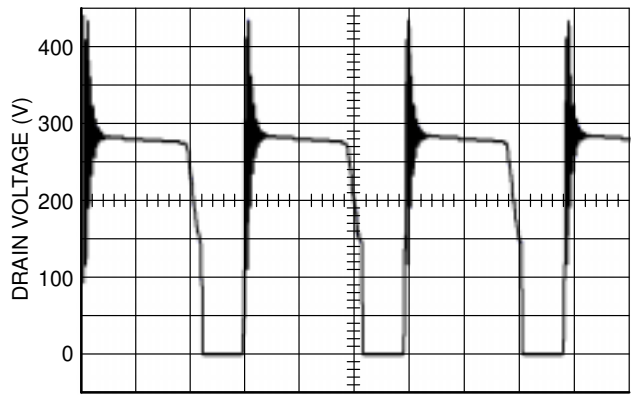

Figure 23. The NCP1207 Operates in Borderline / Critical Operation

Overvoltage Protection

The overvoltage protection works by sampling the plateau voltage 4.5 μ s after the turn-off sequence. This delay guarantees a clean plateau, providing that the leakage inductance ringing has been fully damped. If this would not be the case, the designer should install a small RC damper across the transformer primary inductance connections. Figure 24 shows where the sampling occurs on the auxiliary winding.

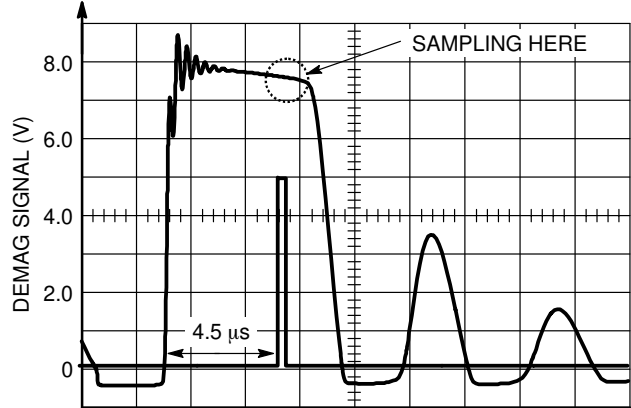

Figure 24. A voltage sample is taken 4.5 μ s after the turn-off sequence

When an OVP condition has been detected, the NCP1207 enters a lathoff phase and stops all switching operations. The controller stays fully latched in this position and the DSS is still active, keeping the V_{CC} between 5.3 V/12 V as in normal operations. This state lasts until the V_{CC} is cycled down 4 V, e.g. when the user unplugs the power supply from the mains outlet.

By default, the OVP comparator is biased to a 5 V reference level and pin 1 is routed via a divide by 1.44 network. As a result, when V_{pin1} reaches 7.2 V, the OVP comparator is triggered. The threshold can thus be adjusted by either modifying the power winding to auxiliary winding turn ratios to match this 7.2 V level, or insert a resistor from pin1 to ground to cope with your design requirement.

Latching Off the NCP1207

In certain cases, it can be very convenient to externally shut down permanently the NCP1207 via a dedicated signal, e.g. coming from a temperature sensor. The reset occurs when the user unplugs the power supply from the mains outlet. To trigger the latching off, a CTN (Figure 25) or a simple NPN transistor (Figure 26) can do the work.

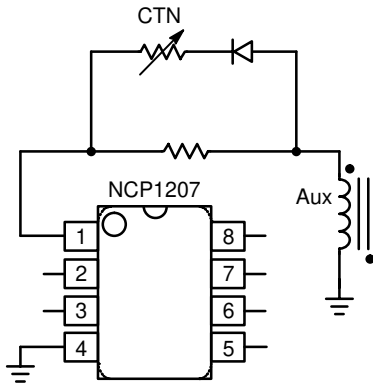

Figure 25. A simple CTN triggers the latching off as soon as the temperature exceeds a given setpoint

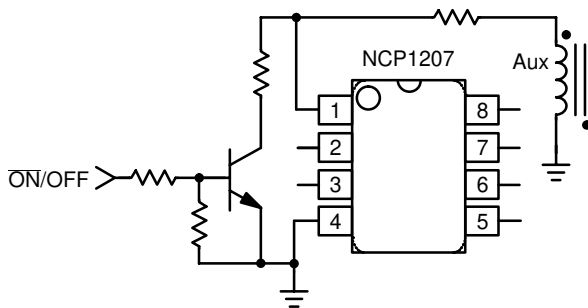

Figure 26. A simple transistor arrangement allows to trigger the latching off by an external signal

Shutting Off the NCP1207

Shutdown can easily be implemented through a simple NPN bipolar transistor as depicted by Figure 27. When OFF, Q1 is transparent to the operation. When forward biased, the transistor pulls the FB pin to ground ($V_{CE(sat)} \approx 200$ mV) and permanently disables the IC. A small time constant on the transistor base will avoid false triggering (Figure 27).

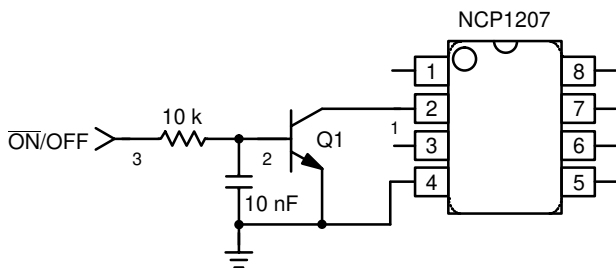

Figure 27. A simple bipolar transistor totally disables the IC

Power Dissipation

The NCP1207 is directly supplied from the DC rail through the internal DSS circuitry. The DSS being an auto-adaptive circuit (e.g. the ON/OFF Duty Cycle adjusts itself depending on the current demand), the current flowing through the DSS is therefore the direct image of the NCP1207 current consumption. The total power dissipation can be evaluated using: $(V_{HVDC} - 11 \text{ V}) \cdot I_{CC2}$. If we operate the device on a 250 Vac rail, the maximum rectified voltage can go up to 350 Vdc. As a result, the worse case dissipation occurs at the maximum switching frequency and the highest line. The dissipation is actually given by the internal consumption of the NCP1207 when driving the selected MOSFET. The best method to evaluate this total consumption is probably to run the final circuit from a 50 Vdc source applied to pin 8 and measure the average current flowing into this pin. Suppose that we find 2.0 mA, meaning that the DSS Duty Cycle will be $2.0/7.0 = 28.6\%$. From the 350 Vdc rail, the part will dissipate: $350 \text{ V} \cdot 2.0 \text{ mA} = 700 \text{ mW}$ (however this 2.0 mA number will drop at higher operating junction temperatures). A DIP8 package offers a junction-to-ambient thermal resistance $R_{\theta JA}$ of 100°C/W . The maximum power dissipation can thus be computed knowing the maximum operating ambient temperature (e.g. 70°C) together with the maximum allowable junction temperature (125°C):

$$P_{\text{max}} = \frac{T_{J\text{max}} - T_{A\text{max}}}{R_{\theta JA}} < 550 \text{ mW}$$

As we can see, we do not reach the worse consumption budget imposed by the operating conditions. Several solutions exist to cure this trouble:

- The first one consists in adding some copper area around the NCP1207 DIP8 footprint. By adding a min pad area of 80 mm^2 of $35 \mu\text{m}$ copper (1 oz.) $R_{\theta JA}$ drops to about 75°C/W . Maximum power then grows up to 730 mW.
- A resistor R_{drop} needs to be inserted with pin 8 to
 - a) avoid negative spikes at turn-off (see below)
 - b) split the power budget between this resistor and the package. The resistor is calculated by leaving at least 50 V on pin 8 at minimum input voltage (suppose 100 Vdc in our case): $R_{\text{drop}} \leq \frac{V_{\text{bulkmin}} - 50 \text{ V}}{7.0 \text{ mA}} < 7.1 \text{ k}\Omega$. The power dissipated by the resistor is thus:

$$\begin{aligned}
 P_{\text{drop}} &= V_{\text{dropRMS}}^2 / R_{\text{drop}} \\
 &= \frac{(I_{\text{DSS}} \cdot R_{\text{drop}} \cdot \sqrt{\text{DSSduty - cycle}})^2}{R_{\text{drop}}} \\
 &= \frac{(7.0 \text{ mA} \cdot 7.1 \text{ k}\Omega \cdot \sqrt{0.286})^2}{7.1 \text{ k}\Omega} = 99.5 \text{ mW}
 \end{aligned}$$

Please refer to the application note AND8069 available from www.onsemi.com/pub/ncp1200.

- If the power consumption budget is really too high for the DSS alone, connect a diode between the auxiliary winding and the V_{CC} pin which will disable the DSS operation ($V_{CC} > 10\text{ V}$).

The SOIC package offers a $178^{\circ}\text{C}/\text{W}$ thermal resistor. Again, adding some copper area around the PCB footprint will help decrease this number: $12\text{ mm} \times 12\text{ mm}$ to drop $R_{\theta\text{JA}}$ down to $100^{\circ}\text{C}/\text{W}$ with $35\text{ }\mu\text{m}$ copper thickness (1 oz.) or $6.5\text{ mm} \times 6.5\text{ mm}$ with $70\text{ }\mu\text{m}$ copper thickness (2 oz.). As one can see, we do not recommend using the SO-8 package and the DSS if the part operates at high switching frequencies. In that case, an auxiliary winding is the best solution.

Overload Operation

In applications where the output current is purposely not controlled (e.g. wall adapters delivering raw DC level), it is interesting to implement a true short-circuit protection. A short-circuit actually forces the output voltage to be at a low level, preventing a bias current to circulate in the Optocoupler LED. As a result, the FB pin level is pulled up to 4.2 V, as internally imposed by the IC. The peak current setpoint goes to the maximum and the supply delivers a rather high power with all the associated effects. Please note that this can also happen in case of feedback loss, e.g. a broken Optocoupler. To account for this situation, NCP1207 hosts a dedicated overload detection circuitry. Once activated, this circuitry imposes to deliver pulses in a burst manner with a low Duty Cycle. The system recovers when the fault condition disappears.

During the startup phase, the peak current is pushed to the maximum until the output voltage reaches its target and the

feedback loop takes over. This period of time depends on normal output load conditions and the maximum peak current allowed by the system. The time-out used by this IC works with the V_{CC} decoupling capacitor: as soon as the V_{CC} decreases from the $V_{CC\text{OFF}}$ level (typically 12 V) the device internally watches for an overload current situation. If this condition is still present when the $V_{CC\text{ON}}$ level is reached, the controller stops the driving pulses, prevents the self-supply current source to restart and puts all the circuitry in standby, consuming as little as $330\text{ }\mu\text{A}$ typical (I_{CC3} parameter). As a result, the V_{CC} level slowly discharges toward 0. When this level crosses 5.3 V typical, the controller enters a new startup phase by turning the current source on: V_{CC} rises toward 12 V and again delivers output pulses at the $V_{CC\text{OFF}}$ crossing point. If the fault condition has been removed before $V_{CC\text{ON}}$ approaches, then the IC continues its normal operation. Otherwise, a new fault cycle takes place. Figure 28 shows the evolution of the signals in presence of a fault.

Soft-Start

The NCP1207 features an internal 1 ms Soft-Start to soften the constraints occurring in the power supply during startup. It is activated during the power on sequence. As soon as V_{CC} reaches $V_{CC\text{OFF}}$, the peak current is gradually increased from nearly zero up to the maximum clamping level (e.g. 1.0 V). The Soft-Start is also activated during the overcurrent burst (OCP) sequence. Every restart attempt is followed by a Soft-Start activation. Generally speaking, the Soft-Start will be activated when V_{CC} ramps up either from zero (fresh power-on sequence) or 5.3 V, the lathoff voltage occurring during OCP.

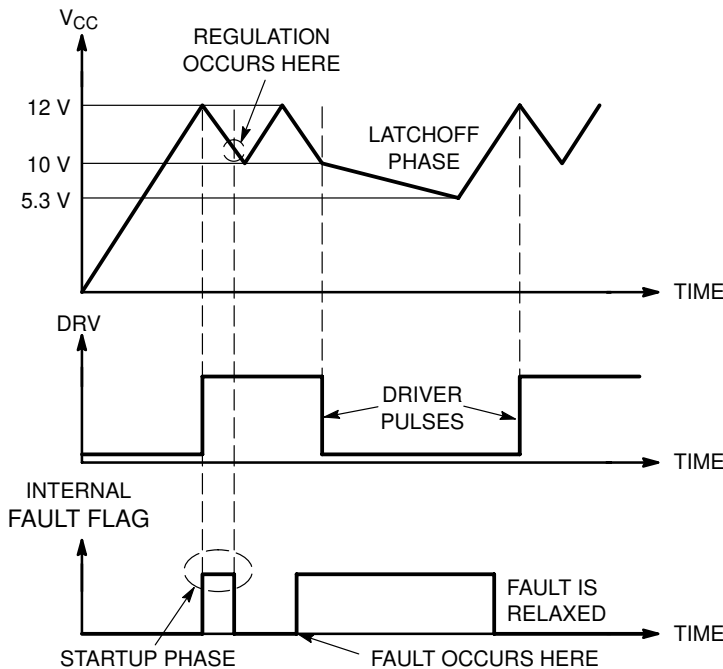

If the fault is relaxed during the V_{CC} natural fall down sequence, the IC automatically resumes.
If the fault still persists when V_{CC} reached $V_{CC\text{ON}}$, then the controller cuts everything off until recovery.

Figure 28.

Calculating the V_{CC} Capacitor

As the above section describes, the fall down sequence depends upon the V_{CC} level: how long does it take for the V_{CC} line to go from 12 V to 10 V? The required time depends on the startup sequence of your system, i.e. when you first apply the power to the IC. The corresponding transient fault duration due to the output capacitor charging must be less than the time needed to discharge from 12 V to 10 V, otherwise the supply will not properly start. The test consists in either simulating or measuring in the lab how much time the system takes to reach the regulation at full load. Let's suppose that this time corresponds to 6.0 ms. Therefore a V_{CC} fall time of 10 ms could be well appropriated in order to not trigger the overload detection circuitry. If the corresponding IC consumption, including the MOSFET drive, establishes at 1.8 mA (e.g. with an 11 nC MOSFET), we can calculate the required capacitor using the following formula: $\Delta t = \frac{\Delta V \cdot C}{i}$, with $\Delta V = 2.0$ V. Then for a wanted Δt of 10 ms, C equals 9.0 μ F or 22 μ F for a standard value. When an overload condition occurs, the IC blocks its internal circuitry and its consumption drops to 330 μ A typical. This happens at V_{CC} = 10 V and it remains stuck until V_{CC} reaches 5.3 V: we are in lathoff phase. Again, using the calculated 22 μ F and 330 μ A current consumption, this lathoff phase lasts: 313 ms.

HV Pin Recommended Protection

When the user unplugs a power supply built with a QR controller such as the NCP1207, two phenomena can appear:

1. A negative ringing can take place on pin8 due to a resonance between the primary inductance and the bulk capacitor. As any CMOS device, the NCP1207 is sensitive to negative voltages that could appear on it's pins and could create an internal latchup condition.
2. When the bulk capacitor discharges, the internal latch is reset by the voltage developed over the sense resistor and the ON time expands as less voltage is available. When the high-voltage rail becomes too low, the gate drives permanently stays high since no reset occurs. This situation is not desirable in many applications.

For the above reasons, we strongly recommend to add a high-voltage diode like a 1N4007 between the bulk capacitor and the V_{CC} pin. When the bulk level collapses, it naturally shuts the controller down and eradicates the two above problems.

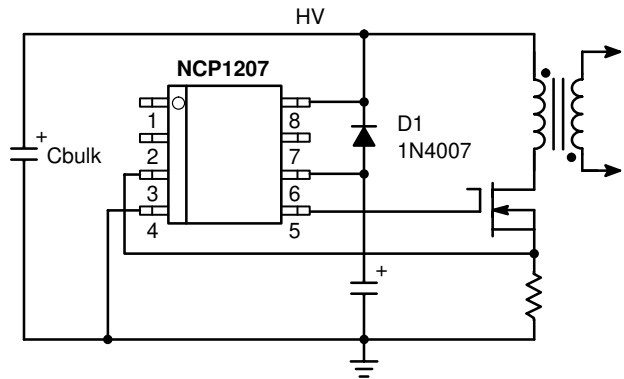

Figure 29.

Operation Shots

Below are some oscilloscope shots captured at V_{in} = 120 VDC with a transformer featuring a 800 μ H primary inductance.

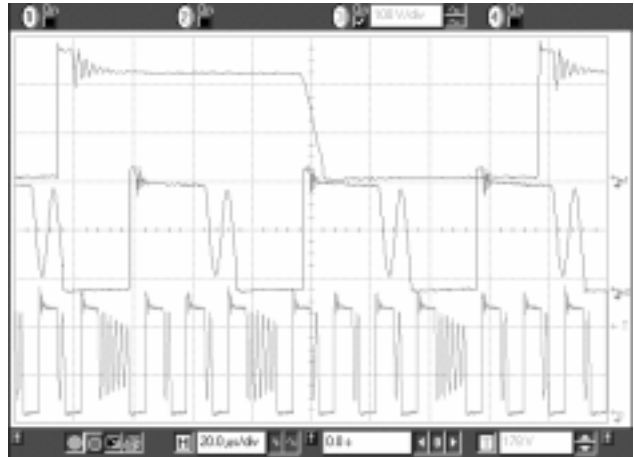

Figure 30.

This plot gathers waveforms captured at three different operating points:

- 1st upper plot: free run, valley switching operation, P_{out} = 26 W
- 2nd middle plot: min T_{off} clamps the switching frequency and selects the second valley
- 3rd lowest plot: the skip slices the second valley pattern and will further expand the burst as P_{out} goes low

NCP1207

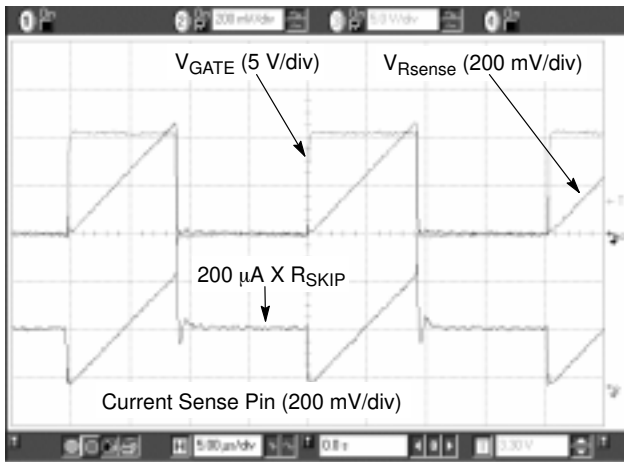

Figure 31.

This picture explains how the $200 \mu A$ internal offset current creates the skip cycle level.

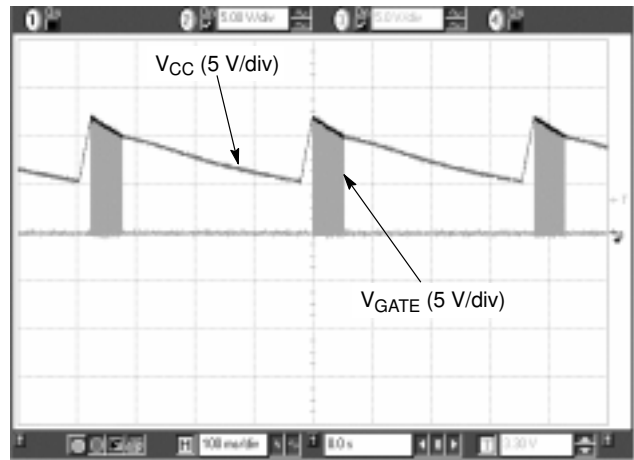

Figure 32.

The short-circuit protection forces the IC to enter burst in presence of a secondary overload.

NCP1207

PACKAGE DIMENSIONS

SOIC-8
D1, D2 SUFFIX
CASE 751-07
ISSUE AC

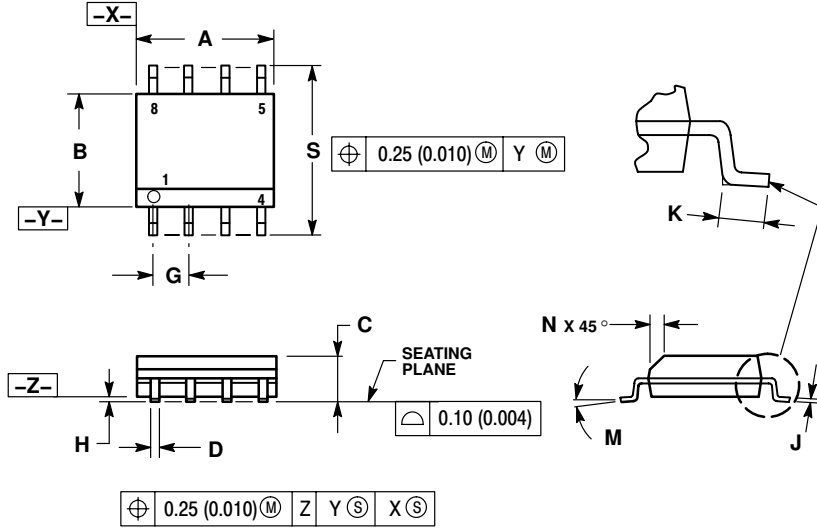

NOTES:

1. DIMENSIONING AND TOLERANCING PER ANSI Y14.5M, 1982.
2. CONTROLLING DIMENSION: MILLIMETER.
3. DIMENSION A AND B DO NOT INCLUDE MOLD PROTRUSION.
4. MAXIMUM MOLD PROTRUSION 0.15 (0.006) PER SIDE.
5. DIMENSION D DOES NOT INCLUDE DAMBAR PROTRUSION. ALLOWABLE DAMBAR PROTRUSION SHALL BE 0.127 (0.005) TOTAL IN EXCESS OF THE D DIMENSION AT MAXIMUM MATERIAL CONDITION.
6. 751-01 THRU 751-06 ARE OBSOLETE. NEW STANDARD IS 751-07.

| DIM | MILLIMETERS | | INCHES | |
|-----|-------------|------|-----------|-------|
| | MIN | MAX | MIN | MAX |
| A | 4.80 | 5.00 | 0.189 | 0.197 |
| B | 3.80 | 4.00 | 0.150 | 0.157 |
| C | 1.35 | 1.75 | 0.053 | 0.069 |
| D | 0.33 | 0.51 | 0.013 | 0.020 |
| G | 1.27 BSC | | 0.050 BSC | |
| H | 0.10 | 0.25 | 0.004 | 0.010 |
| J | 0.19 | 0.25 | 0.007 | 0.010 |
| K | 0.40 | 1.27 | 0.016 | 0.050 |
| M | 0° | 8° | 0° | 8° |
| N | 0.25 | 0.50 | 0.010 | 0.020 |
| S | 5.80 | 6.20 | 0.228 | 0.244 |

SOLDERING FOOTPRINT*

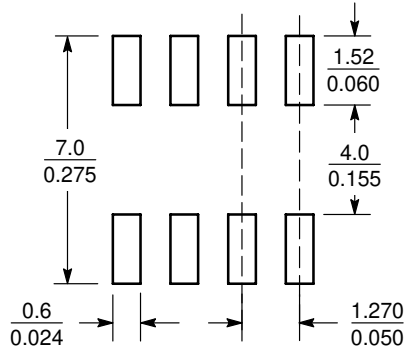

SCALE 6:1 (mm/inches)

*For additional information on our Pb-Free strategy and soldering details, please download the ON Semiconductor Soldering and Mounting Techniques Reference Manual, SOLDERRM/D.

NCP1207

PACKAGE DIMENSIONS

PDIP-8
N SUFFIX
CASE 626-05
ISSUE L

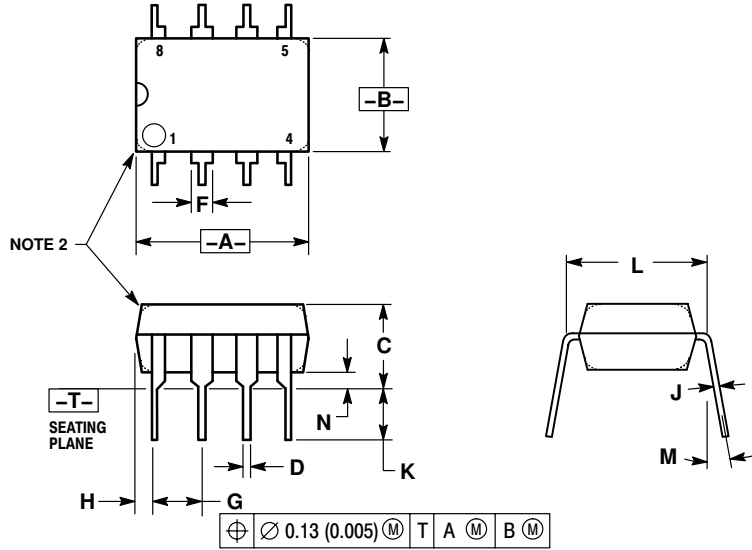

- NOTES:
1. DIMENSION L TO CENTER OF LEAD WHEN FORMED PARALLEL.
 2. PACKAGE CONTOUR OPTIONAL (ROUND OR SQUARE CORNERS).
 3. DIMENSIONING AND TOLERANCING PER ANSI Y14.5M, 1982.

| DIM | MILLIMETERS | | INCHES | |
|-----|-------------|-------|-----------|-------|
| | MIN | MAX | MIN | MAX |
| A | 9.40 | 10.16 | 0.370 | 0.400 |
| B | 6.10 | 6.60 | 0.240 | 0.260 |
| C | 3.94 | 4.45 | 0.155 | 0.175 |
| D | 0.38 | 0.51 | 0.015 | 0.020 |
| F | 1.02 | 1.78 | 0.040 | 0.070 |
| G | 2.54 BSC | | 0.100 BSC | |
| H | 0.76 | 1.27 | 0.030 | 0.050 |
| J | 0.20 | 0.30 | 0.008 | 0.012 |
| K | 2.92 | 3.43 | 0.115 | 0.135 |
| L | 7.62 BSC | | 0.300 BSC | |
| M | --- | 10° | --- | 10° |
| N | 0.76 | 1.01 | 0.030 | 0.040 |

NCP1207

The product described herein (NCP1207), may be covered by one or more of the following U.S. patents: 6,362,067, 6,385,060, 6,385,061, 6,429,709, 6,587,357, 6,633,193. There may be other patents pending.

ON Semiconductor and  are registered trademarks of Semiconductor Components Industries, LLC (SCILLC). SCILLC reserves the right to make changes without further notice to any products herein. SCILLC makes no warranty, representation or guarantee regarding the suitability of its products for any particular purpose, nor does SCILLC assume any liability arising out of the application or use of any product or circuit, and specifically disclaims any and all liability, including without limitation special, consequential or incidental damages. "Typical" parameters which may be provided in SCILLC data sheets and/or specifications can and do vary in different applications and actual performance may vary over time. All operating parameters, including "Typicals" must be validated for each customer application by customer's technical experts. SCILLC does not convey any license under its patent rights nor the rights of others. SCILLC products are not designed, intended, or authorized for use as components in systems intended for surgical implant into the body, or other applications intended to support or sustain life, or for any other application in which the failure of the SCILLC product could create a situation where personal injury or death may occur. Should Buyer purchase or use SCILLC products for any such unintended or unauthorized application, Buyer shall indemnify and hold SCILLC and its officers, employees, subsidiaries, affiliates, and distributors harmless against all claims, costs, damages, and expenses, and reasonable attorney fees arising out of, directly or indirectly, any claim of personal injury or death associated with such unintended or unauthorized use, even if such claim alleges that SCILLC was negligent regarding the design or manufacture of the part. SCILLC is an Equal Opportunity/Affirmative Action Employer. This literature is subject to all applicable copyright laws and is not for resale in any manner.

PUBLICATION ORDERING INFORMATION

LITERATURE FULFILLMENT:

Literature Distribution Center for ON Semiconductor
P.O. Box 61312, Phoenix, Arizona 85082-1312 USA
Phone: 480-829-7710 or 800-344-3860 Toll Free USA/Canada
Fax: 480-829-7709 or 800-344-3867 Toll Free USA/Canada
Email: orderlit@onsemi.com

N. American Technical Support: 800-282-9855 Toll Free
USA/Canada

Japan: ON Semiconductor, Japan Customer Focus Center
2-9-1 Kamimeguro, Meguro-ku, Tokyo, Japan 153-0051
Phone: 81-3-5773-3850

ON Semiconductor Website: <http://onsemi.com>

Order Literature: <http://www.onsemi.com/litorder>

For additional information, please contact your
local Sales Representative.