



Chipsmall Limited consists of a professional team with an average of over 10 year of expertise in the distribution of electronic components. Based in Hongkong, we have already established firm and mutual-benefit business relationships with customers from,Europe,America and south Asia,supplying obsolete and hard-to-find components to meet their specific needs.

With the principle of “Quality Parts,Customers Priority,Honest Operation,and Considerate Service”,our business mainly focus on the distribution of electronic components. Line cards we deal with include Microchip,ALPS,ROHM,Xilinx,Pulse,ON,Everlight and Freescale. Main products comprise IC,Modules,Potentiometer,IC Socket,Relay,Connector.Our parts cover such applications as commercial,industrial, and automotives areas.

We are looking forward to setting up business relationship with you and hope to provide you with the best service and solution. Let us make a better world for our industry!



Contact us

Tel: +86-755-8981 8866 Fax: +86-755-8427 6832

Email & Skype: info@chipsmall.com Web: www.chipsmall.com

Address: A1208, Overseas Decoration Building, #122 Zhenhua RD., Futian, Shenzhen, China



NCP1230GEVB

NCP1230 90 Watt, Universal Input Adapter Power Supply Evaluation Board User's Manual



ON Semiconductor®

<http://onsemi.com>

EVAL BOARD USER'S MANUAL

General Description

The NCP1230 implements a standard current mode control architecture. It's an ideal candidate for applications where a low parts count is a key parameter, particularly in low cost adapter power supplies. The NCP1230 combines a low standby power mode with an event management scheme that will disable a PFC circuit during Standby, thus reducing the no load power consumption. The 90 W Evaluation Board demonstrates the wide range of features found on the NCP1230 controller.

The NCP1230 has a PFC_Vcc output pin which provides Vcc power for a PFC controller, or other circuitry. The PFC_Vcc pin is enabled when the output of the power supply is up and in regulation. In the event that there is an output fault, the PFC_Vcc pin is turned off, disabling the PFC controller, reducing the stress on the PFC semiconductors.

In addition to excellent no load power consumption, the NCP1230 provides an internal latching function that can be used for over voltage protection by pulling the CS pin above 3.0 V.

Features

- Current-Mode Control
- Lossless Startup Circuit
- Operation Over the Universal Input Range
- Direct Connection to PFC Controller
- Low Standby
- Overvoltage Protection

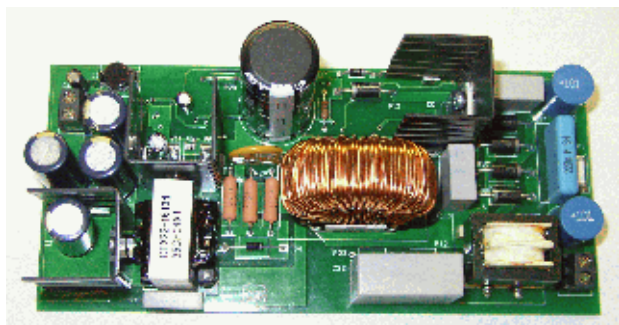

Figure 1. Evaluation Board Photo

Design Specification

This Demo Board is configured as a two stage adapter power supply. The first stage operates off of the universal input, 85–265 Vac, 50–60 Hz, using the MC33260 Critical Conduction Mode controller, in the Boost Follower mode. The output voltage from the Boost Follower (when Vin is 85 Vac) is 200 V and as the input line increases to 230 Vac the output of the Boost Follower will ramp up to 400 Vdc. The second stage of the power supply features the NCP1230 driving a flyback power stage. The output of the second stage is 19 Vdc capable of 90 W of output power. It is fully self-contained and includes a bias supply that operates off of the Auxiliary winding of the transformer.

Table 1. EVALUATION BOARD SPECIFICATIONS

Requirement	Symbol	Min	Max
Input	Vac	85	265
Frequency	Hz	47	63
Vo	Vdc	18.6	19.38
Io	Adc	–	4.74
Output Power	W	–	90
efficiency	η	80	–
Standby Power Vin 230 Vac	mW	–	150
Pin Short Circuit Load Vin 230 Vac	mW		100
Pin with 0.5 W Load Vin 230 Vac	mW	–	0.8

PFC

The MC33260 is configured as a Boost Follower operating from the universal input line. The PFC section was designed to provide approximately 116 W of power.

$$I_{pk} = \frac{2 \cdot \sqrt{2} \cdot P_{in \max}}{V_{ac}}$$

$$I_{pk} = \frac{2 \cdot \sqrt{2} \cdot 116}{85} = 3.86 \text{ A}$$

NCP1230GEVB

The MC33260 is a Critical Conduction Mode controller; as a result the switching frequency is a function of the boost inductor and the timing capacitor. In this application the minimum operating frequency is 30 kHz.

$$L_p = \frac{2 \cdot T_p \left(\frac{V_o}{\sqrt{2}} - V_{ac} \right) \cdot (V_{ac})^2}{V_o \cdot V_{ac} \cdot I_{pk}}$$

$$L_p = \frac{2 \cdot 33.33 \left(\frac{200}{\sqrt{2}} - 85 \right) \cdot (85)^2}{200 \cdot 85 \cdot 3.86} = 414 \mu\text{H}$$

The value used is 400 μH .

Where:

$$T_p = \frac{1}{\text{Freq}_{\min}} = \frac{1}{30} = 33.33 \mu\text{sec}$$

$V_{\min} = 200 \text{ Vdc}$ (@ 85 Vac input)

$V_{ac} = 85 \text{ Vac}$

The oscillator timing capacitor is calculated by the following formula:

$$C_T = \frac{4 V_o^2 K_{osc} L_p P_{in}}{R_o^2 V_{pk}^2} - C_{int}$$

$$C_T = \frac{4 \cdot 200^2 \cdot 6400 \cdot 400 \cdot 116}{2^2 \cdot 120^2} - 15 = 809 \text{ pF}$$

Where:

$K_{osc} = 6400$

$R_o = 2.0 \text{ M}\Omega$ (feedback resistor)

The C_T value used is 820 pF

Refer to the ON Semiconductor website for Application Note AND8123/D for additional MC33260 application information, and the Excel based development tool DDTMC33260/D.

Startup Circuit Description

The High Voltage pin (pin 8) of the NCP1230 controller is connected directly to the high voltage DC bus. When the input power is turned on, an internal current source is turned on (typically 3.0 mA) charging up an external capacitor on the Vcc pin. When the Vcc capacitor is above V_{CCoff} , the current source is turned off, and the controller delivers output drive pulses to an external MOSFET, Q1. The MOSFET, Q1, drives the primary of the transformer T1. The transformer has two additional windings, the auxiliary winding which provides power to the controller after the power supply is running, and the secondary winding which provided the 19 Vdc output power.

Transformer

The transformer primary inductance was selected so the current would be discontinuous under all operating conditions. As a result the total switching period, $T_{on} + T_{off}$, must be less than or equal to $1/\text{frequency}$.

The following assumptions were used in the design process:

$D_{\max} = 0.4$ Duty Cycle

Vdc bus = 200 Vdc input with Vin 85 Vac

Efficiency = 0.80

Freq = 65 kHz

$V_o = 19 \text{ V}$

$V_f = 0.7$

$P_o = 90 \text{ W}$

$$P_{in} = \frac{P_o}{\eta} = \frac{90}{0.8} = 112.5 \text{ W}$$

$$I_{avg} = \frac{P_{in}}{V_{in}} = \frac{112.5}{200} = 0.566$$

$$L_p = \frac{2 \cdot P_{in}}{\left(\frac{2 \cdot I_{avg}}{D_{\max}} \right) \cdot \text{Freq}}$$

$$L_p = \frac{2 \cdot 112.5}{\left(\frac{2 \cdot 0.566}{0.4} \right)^2 \cdot 65} = 432 \mu\text{H}$$

In this application the primary inductance used is 220 μH . This takes into consideration the transformer tolerances, and to minimize the transformer size. Once the primary inductance has been calculated, the next step is to determine the peak primary current.

$$P_{in} = \frac{1}{2} \cdot I_{pk}^2 \cdot L_p \cdot f$$

$$I_{pk} = \sqrt{\frac{P_{in} \cdot 2}{L_p \cdot f}}$$

$$I_{pk} = \sqrt{\frac{2 \cdot 112.5}{220 \cdot 65}} = 3.97 \text{ Apk}$$

The following calculations are used to verify that the current will be Discontinuous under all operating conditions.

$$T_p = T_{on} + T_{off} > \frac{1}{\text{freq}}$$

$$T_{on} = \frac{L_p \cdot I_{pk}}{V_{in}}$$

$$T_{off} = \frac{L_s \cdot I_{opk}}{V_o + V_f}$$

$$T_p = \left(\frac{L_p \cdot I_{pk}}{V_{in}} \right) + \left(\frac{L_s \cdot I_{opk}}{V_o + V_f} \right)$$

Where:

$$L_s = \frac{L_p}{n^2}$$

n is the transformer turns ratio 6.77

$$T_p = \frac{220 \cdot 3.97}{200} + \frac{4.8 \cdot 27.22}{19 + 0.7} = 10 \mu\text{s}$$

With a primary inductance value of 220 μH , $T_{on} + T_{off}$ is less than the controller switching period. An Excel spreadsheet was designed using the above equation to help calculate the correct primary inductance value; visit the ON Semiconductor website for a copy of the spreadsheet.

NCP1230GEVB

One method for calculating the transformer turns ratio is to minimize the voltage stress of the MOSFET (V_{DS}) due to the reflected output voltage.

$$V_{DSmax} = V_{inmax} + n \cdot (V_o + V_f) + V_{spike}$$

In this application an 800 V MOSFET was selected. The goal, for safety purposes, is to limit V_{DSmax} at high line (including the V_{spike}) to 700 V. To limit the power dissipation in the snubber clamp (refer to the section in the Applications Note titled “Snubber”.) V_{spike} is clamped at 167 V.

$$n = \frac{V_{DSmax} - V_{inmax} - V_{spike}}{V_o + V_f}$$

$$n = \frac{700 - 400 - 167}{19.7} = 6.77$$

The NCP1230 requires that the controller V_{cc} be supplied through an auxiliary winding on the transformer. The nominal supply voltage for the controller is 13 Vdc.

$$n_{aux} = \frac{V_{aux}(1-D_{max})}{V_{in} \cdot D_{max}}$$

$$n_{aux} = \frac{13.7(1-0.4)}{200(0.4)} = 0.128$$

The supply voltage to the controller may be higher than the calculated value because of the transformer leakage inductance. The leakage inductance spike on the auxiliary winding is averaged by the rectifier D2 and capacitor C5. Because of this, an 18 V Zener diode (D18 refer to the Demo Board Schematic Figure 10) is connected from the V_{cc} pin to ground. To limit the current into the Zener diode a 200 Ω resistor is placed between C5 and the V_{cc} pin (R28).

ON Semiconductor recommends that the V_{cc} capacitor be at least 47 μ F to be sure that the V_{cc} supply voltage does not drop below V_{ccmin} (7.6 V typical) during standby power mode and unusual fault conditions.

The transformer primary rms current is:

$$I_{rms} = I_{pk} \sqrt{\frac{D_{on}}{3}} = 3.97 \sqrt{\frac{0.4}{3}} = 1.45 \text{ Arms}$$

The transformer secondary rms current is:

$$I_{rms_sec} = I_{pk_prim} \cdot n \sqrt{\frac{1-D}{3}}$$

$$= 3.97 \cdot 6.77 \sqrt{\frac{0.6}{3}} = 12.02 \text{ Arms}$$

The transformer for the Demo Board was manufactured by Cooper Electronics Technologies (www.cooperET.com) part number CTX22-16134. The designer should take precautions that under startup conditions, the transformer will not saturate at the low input ac line (85 Vac) and full load conditions. The above calculation assumed that the adapter was running and the PFC front end was enabled.

Output Filter

One of the disadvantages of a Flyback converter operating in the Discontinuous mode is there is a large ripple current

in the output capacitor(s). As a result you may be required to use multiple capacitors in parallel to handle the ripple current.

$$I_{cap_ripple} = \sqrt{I_{rms}^2 + I_o^2}$$

$$I_{cap_ripple} = \sqrt{12.02^2 - 4.74^2} = 11.04 \text{ A}$$

$$T_{on} = \frac{1}{\text{frequency}} \cdot 0.4 = \frac{1}{65000} \cdot 0.4 = 6.15 \mu\text{sec}$$

$$C_o = \frac{I_{rms} \cdot (T - T_{on})}{V_{ripple}}$$

Where $V_{ripple} = 50 \text{ mV}$.

$$C_o = \frac{12.02 \cdot (15.38 - 9.23)}{0.05} = 1,478 \mu\text{F}$$

In the 90 W Adapter design four 2200 μ F (8800 μ F total) capacitors (C2, C3, C14, and C15) were required in parallel to handle the ripple current.

A small LC filter has been added to the output of the power supply to help reduce the output ripple. The cut-off frequency for the filter is:

$$f_p = \frac{1}{2\pi\sqrt{LC}} = \frac{1}{2\pi\sqrt{2.2 \cdot 47}} = 15.6 \text{ kHz}$$

$$L1 = 2.2 \mu\text{H}$$

$$C8 = 47 \mu\text{F}$$

Output Rectifying Diode

The rectifying diode was selected based upon on the peak inverse voltage and the diodes average forward current. The peak inverse voltage across the secondary of the transformer is:

$$P_{IV} = \frac{V_{in}}{n} + V_o$$

$$P_{IV} = \frac{400}{6.77} + 19 = 78 \text{ Vpk}$$

The average current through the diode is:

$$I_{avg} = \frac{P_o}{V_o} = \frac{90}{19} = 4.74 \text{ A}$$

An MBR20100CT Schottky diode was selected; it is rated for a V_{RRM} of 100 V, with an average forward current of 10 A.

Power Switch

A MOSFET was selected as the power switching element. Several factors were used in selecting the MOSFET; current, voltage stress (V_{DS}), and $R_{DS(on)}$.

The rms current through the primary of the transformer is the same as the current in the MOSFET, which is 1.45 Arms. The MOSFET selected is manufactured by Infineon, part number SPP11N80C3. It is rated for 800 VDS and 11 Arms, with an $R_{DS(on)}$ of 0.45 Ω .

Snubber

The maximum voltage across the MOSFET is:

$$V_{pk} = V_{in\ max} + (V_o + V_f)n$$

$$V_{pk} = 400 + (19 + 0.7) 6.77 = 534\ V$$

This calculation neglects the voltage spike when the MOSFET turns off due to the transformer leakage inductance. The spike, due to the leakage inductance, must be clamped to a level below the MOSFETs' maximum VDS. To clamp the voltage spike a resistive, capacitive, diode clamp network was used to prevent the drain voltage from rising above $V_{in} + (V_o + V_f) n + V_{clamp}$. The desired clamp voltage is 700 V; this provides a safety margin of 100 V. The first step is to calculate the snubber resistor.

$$R_{clamp} = \frac{2 \cdot V_{clamp} \cdot (V_{clamp} - V_o \cdot n)}{I_e \cdot I_{pk}^2 \cdot Freq}$$

$$R_{clamp} = \frac{2 \cdot 700 \cdot (700 - (19.7 \cdot 6.77))}{7 \cdot 3.97^2 \cdot 65} = 110\ k\Omega$$

Where:

- V_o = the output voltage
- V_f = the forward voltage drop across the output diode
- n is the transformer turns ratio 6.77
- I_e is the transformer turns ratio of 7 μ H
- The power dissipation in the clamp resistor is:

$$P_{Rclamp} = 0.5 \cdot I_{pk}^2 \cdot I_e \cdot Freq \cdot \left(\frac{V_{clamp}}{V_{clamp} - (V_o \cdot n)} \right)$$

$$P_{Rclamp} = 0.5 \cdot 3.97^2 \cdot 7 \cdot 65 \cdot \left(\frac{700}{700 - (19.7 \cdot 6.77)} \right)$$

$$= 4.4\ W$$

The snubber capacitor can be calculated from the following equation. See Application Note AN1679/D for details of how the snubber equations were derived.

$$C_6 = \frac{V_{clamp}}{V_{ripple} \cdot Freq \cdot R_{clamp}}$$

$$C_6 = \frac{700}{20 \cdot 65 \cdot 110} = 0.005\ \mu F$$

After the initial snubber was calculated, the snubber values were tuned in the circuit to minimize ringing, and minimize the power dissipation. As a result the final circuit values are; R_{clamp} uses three 100 k Ω (33 k Ω equivalent), 2.0 W resistors used in parallel, and C_6 is 0.01 μ F, 1000 V. Refer to Figure 2 for a scope waveform of the Drain to source voltage at full load and high line.

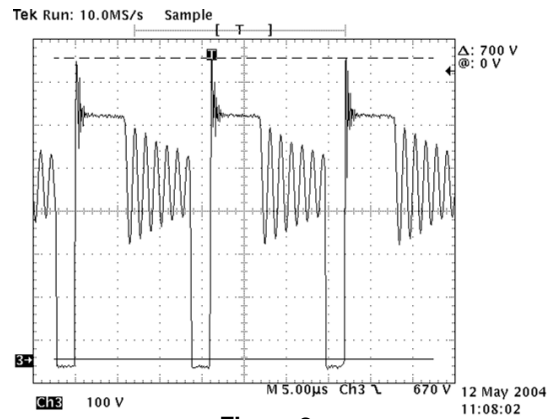

Figure 2.

Current Sense Resistor Selection

The input to the current sense amplifier is clamped to 1.0 V (typical). The current sense resistor should be calculated at 125% of the full rated load to be sure that under all operating conditions the power supply will be able to deliver the full rated power.

$$P_o = 90 \cdot 1.25 = 112.5\ W$$

$$P_{in} = \frac{P_o}{\text{eff}} = \frac{112.5}{0.80} = 140.63\ W$$

$$I_{pk} = \sqrt{\frac{2 \cdot 140.63}{220 \cdot 65}} = 4.43\ A_{pk}$$

$$R_s = \frac{1\ V}{I_{pk}} = \frac{1}{4.43} = 0.23\ \Omega$$

0.2 Ω was used.

To reduce the power dissipation in the sense resistor, two 0.4 Ω resistors were used in parallel.

Overvoltage Protection

The NCP1230 has a fast comparator which only monitors the current sense pin during the power switch off time. If the voltage on the current sense pin rises above 3.0 V (typical), the NCP1230 will immediately stop the output drive pulses and latch-off the controller. The NCP1230 will stay in the Latch-Off mode until V_{cc} has dropped below 4.0 V.

This feature allows the user to implement several protection functions, for example, Overvoltage or Overtemperature Protection.

The Auxiliary winding of the Flyback transformer (T5) can be used for overvoltage protection because the voltage on the Auxiliary winding is proportional to the output voltage.

To implement Overvoltage Protection (OVP), a PNP transistor is used to bias up the current sense pin during the NCP1230 controller off time (refer to Figure 3). The base of the PNP transistor is driven by the NCP1230 drive output (pin 5), if the Auxiliary winding voltage increases above the Zener diode (D1) breakdown voltage, 13 V, current will flow through Q3 biasing up the voltage on the current sense pin. Using typical component values, if the voltage on the Auxiliary winding reaches 16.5 V (3.5 V above the nominal voltage) the NCP1230 will latch-off through the CS input (pin 3).

$$\begin{aligned} \text{OVP}_{\text{threshold}} &= V_z(D1) + V_{ce}Q3 + \text{CS}_{\text{latchoff}} \\ &= 13 \text{ V} + 0.5 \text{ V} + 3.0 \text{ V} = 16.5 \text{ V} \end{aligned}$$

A 13 V Zener diode was selected to have the controller Latch-Off prior to having Vcc reach its maximum allowable voltage level, 18 V.

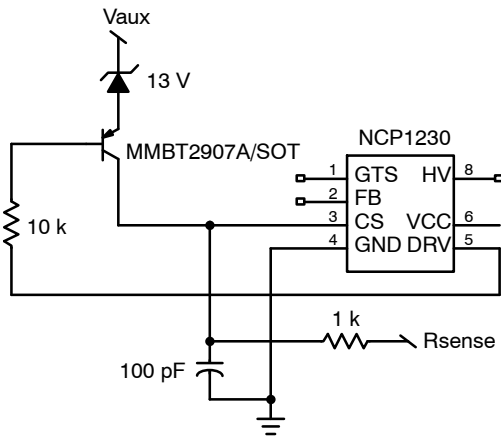

Figure 3. Overvoltage Protection Circuit

Overtemperature Protection

To implement Overtemperature Protection (OTP) shutdown, the Zener diode can be replaced by an NTC (refer to Figure 4), or an NTC can be placed in parallel with the Zener diode to have OVP and OTP protection. When an overtemperature condition occurs, the resistance of the NTC will decrease, allowing current to flow through the PNP transistor biasing up the Current Sense pin.

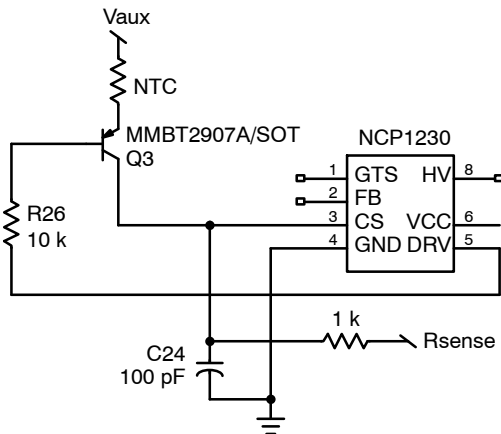

Figure 4. Overtemperature Protection Circuit

Slope Compensation

A Flyback converter operating in continuous conduction mode with a duty cycle greater than 50% requires slope compensation. In this application the power supply will always be operating in the discontinuous mode, so no slope compensation is required.

The resistor R21 and capacitor C24 form a low pass filter suppressing the leading edge of the current signal. Typically, the leading edge of the current will have a large spike due to the transformer leakage inductance. If the spike is not filtered, it can prematurely turn off the MOSFET. The NCP1230 does have a leading edge blanking circuit, but it is a good design practice to add an external filter. The time constant of the filter must be significantly higher than the highest expected operating frequency, but low enough to filter the spike.

Output Control

Feedback theory states that for the control loop to be stable there must be at least 45° of phase margin when the loop gain crosses cross zero dB. The following equations derive the Flyback converter transfer function while operating in the discontinuous continuous mode.

$$P_o = \frac{V_o^2}{R_o}$$

Where:

- Po is the maximum output power
- Vo is the output voltage
- Ro is the output resistance

$$P = \frac{1}{2} \cdot I_{pk}^2 \cdot L_p \cdot f$$

Where:

- I is the peak primary current
- Lp is the transformer primary inductance
- F is the switching frequency of the controller

$$\frac{V_o^2}{R_o} = \frac{1}{2} \cdot I_{pk}^2 \cdot L_p \cdot f$$

$$\frac{V_o}{i} = \sqrt{\frac{R_o \cdot f \cdot L_p}{2}} \cdot n \cdot d$$

$$i = I_p \cdot R_s = \frac{V_c}{3}$$

Where:

- Ip is the peak primary current
- Rs is the current sense resistor
- Vc is the control voltage
- 3, the feedback input voltage is divided down by a factor of three

Combining equations the open loop gain is:

$$\frac{V_o}{i} = \sqrt{\frac{R_o \cdot L_p \cdot f}{2}} \cdot n \cdot d$$

$$i = I_{pk} \cdot R_s = \frac{V_c}{3}$$

$$V_c = 3 \cdot R_s \cdot I_{pk}$$

$$\frac{V_o}{V_c} = \sqrt{\frac{R_o \cdot L_p \cdot f}{2}} \cdot n \cdot d \cdot I_{pk} \cdot R_s \cdot 3$$

With current mode control, there is pole associated with the output capacitor(s) and the load resistors. In this application there are four 2200 μF capacitors in parallel:

$$f_p = \frac{1}{\pi C_o R_o} = \frac{1}{\pi \cdot 8800 \cdot 3.9} = 9.3 \text{ Hz}$$

The secondary filter made up of L1 and C8 does not affect the control loop because we are sensing the output voltage before the LC network.

In addition to the pole, there is a zero associated with the output capacitor(s) and the capacitors esr. The esr of each capacitors is 0.022 Ω (from the data sheet).

$$f_z = \frac{1}{2\pi C_o \cdot esr} = \frac{1}{6.28 \cdot 8800 \cdot \frac{0.022}{4}} = 3.3 \text{ kHz}$$

A small 0.47 nF capacitor (C25) is connected from the feedback pin to ground to reduce the switching noise on the feedback pin. Care must be taken not to have too large a capacitor, or a low frequency pole may be created in the feedback loop.

Output Voltage Regulation

The output voltage regulation is achieved by using a TL431 on the secondary side of the transformer. The output voltage is sensed and divided down to the reference level of the TL431 (2.5 V typical) by the resistive divider network consisting of R4 and R10.

The TL431 requires a minimum of 1.0 mA of current for regulation:

$$R_{opto}(R22) = \frac{V_o - V_{fopto}}{1 \text{ mA}} = \frac{19 - 1}{1 \text{ mA}} = 18 \text{ k}$$

In this application R22 was changed to 1.0 kΩ to minimize the stand by power consumption.

When the power supply is operating at no load, there may not be sufficient current through the optocoupler LED, so a resistor (R7) is placed in parallel. A 4.7 kΩ resistor was selected.

The optocoupler gain is:

$$\frac{\Delta V_{fb}}{\Delta V_c} = \frac{R_{fb} \cdot CTR}{R_{opto}} = \frac{20 \cdot 1.0}{1} = 20$$

$$dB_{gain} = 20 \log 20 = 26 \text{ dB}$$

CTR is the current transfer ratio of the opto and is nominally 1.0, but over time the CTR will degrade so analysis of the circuit with the CTR = 0.5 is recommended.

Rfb is the internal pull-up resistor of the NCP1230 and it is a nominal 20 kΩ.

Standby Power

To minimize the standby power consumption, the output voltage sense resistor divider network was select to consume less than 10 mW.

$$V_{ref} = V_o \left(\frac{R_{10}}{R_{10} + R_4} \right) = 19 \left(\frac{7.4}{7.4 + 50} \right) = 2.5 \text{ V}$$

The Standby power consumption is:

$$P = \frac{V_o^2}{R_{total}} = \frac{19^2}{57400} = 6.3 \text{ mW}$$

Standby power calculation:

$$P_{R22} = I^2 \cdot R22 = 1^2 \text{ ma} \cdot 2 \text{ k} = 2 \text{ mW}$$

$$P_{TL431} = (V_o - V_{R22} - V_{opto}) \cdot 1 \text{ ma} \\ = 17 \text{ V} \cdot 1 \text{ ma} = 17 \text{ mW}$$

Control Loop

Two methods were used to verify that the Demo Board loop was stable, the results are shown below. The first method was to use an Excel Spreadsheet (using the previously derived equations) which can be down loaded from the ON Semiconductor website (www.onsemi.com). The results from the Excel Spreadsheet are shown below. At full load and 200 Vdc (200 Vdc is the minimum voltage being supplied from the PFC) the loop gain crosses zero dB at approximately 1.2 kHz with approximately 100° of phase margin.

The second method was to model the NCP1230 Demo Board in PSPICE. The result can be seen in Figure 7. Because parasitic elements can be added to the PSPICE model, it was more accurate at high frequencies.

The results from the PSPICE model (at low frequencies) shows similar results, the loop gain crosses zero dB at approximately 1.2 kHz with about 90° of phase margin.

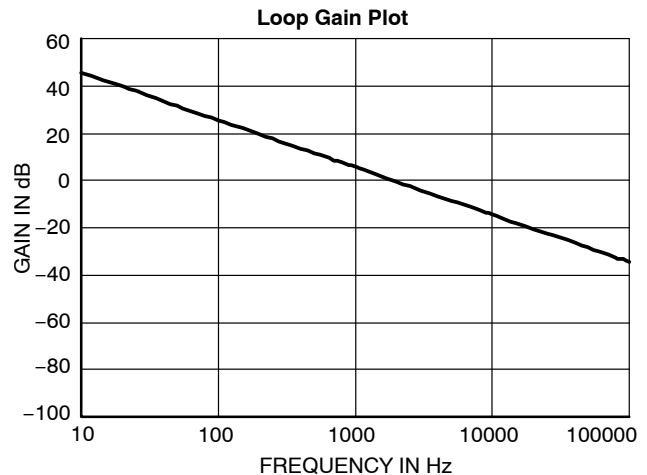

Figure 5. Excel Spreadsheet Loop Gain

NCP1230GEVB

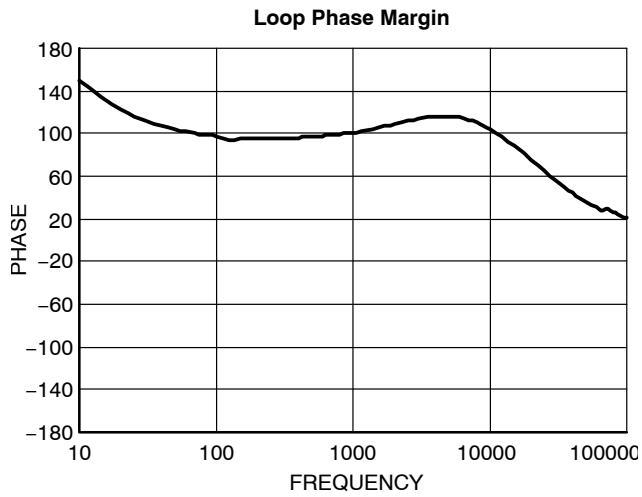

Figure 6. Excel Spreadsheet Phase Margin

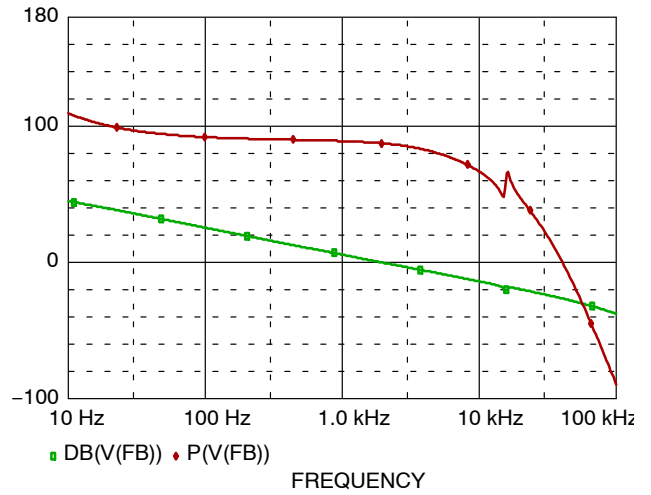

Figure 7. SPICE Phase/Gain

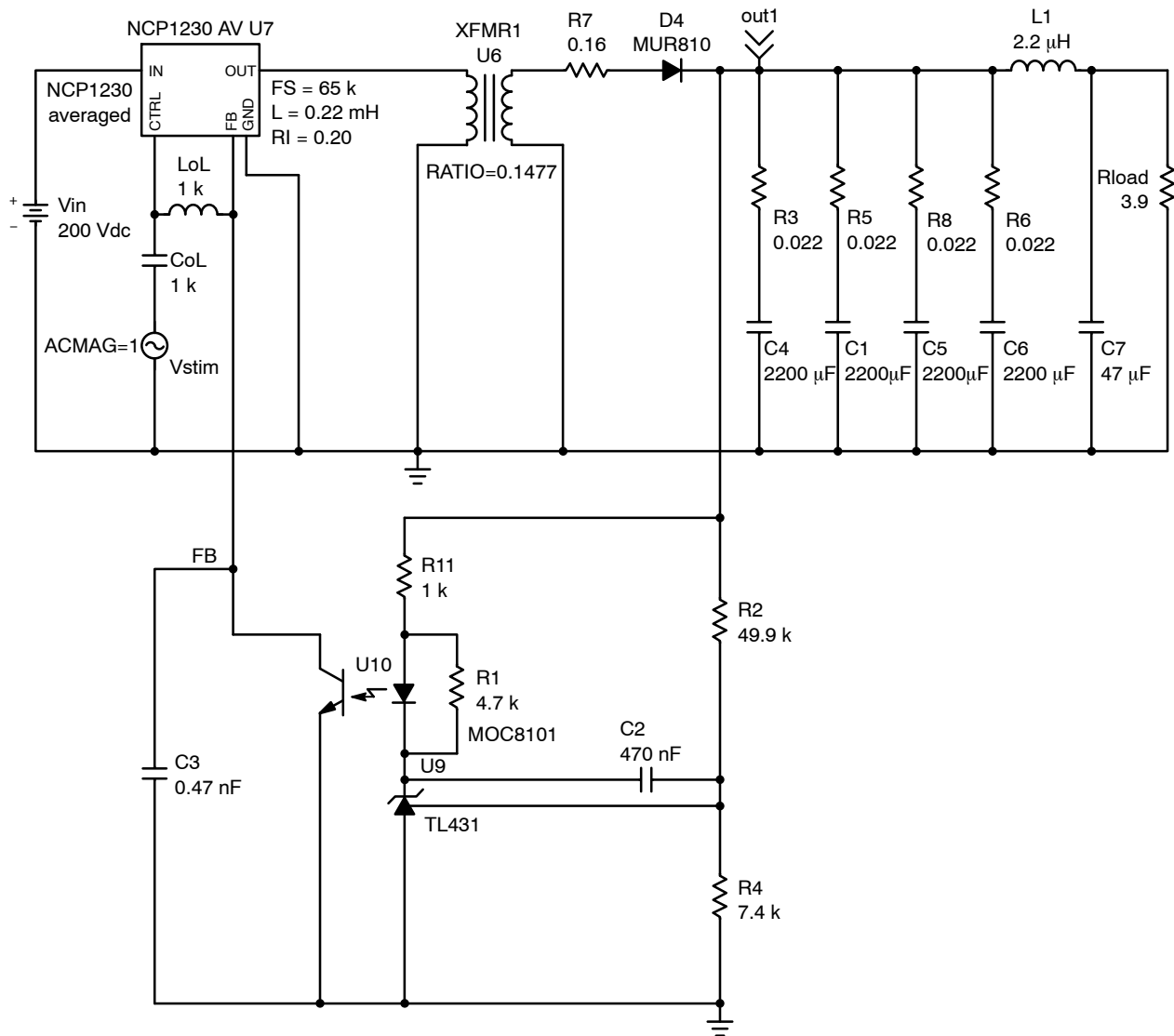

Figure 8. AC Frequency Response SPICE Model

NCP1230GEVB

Evaluation Board Test Procedure

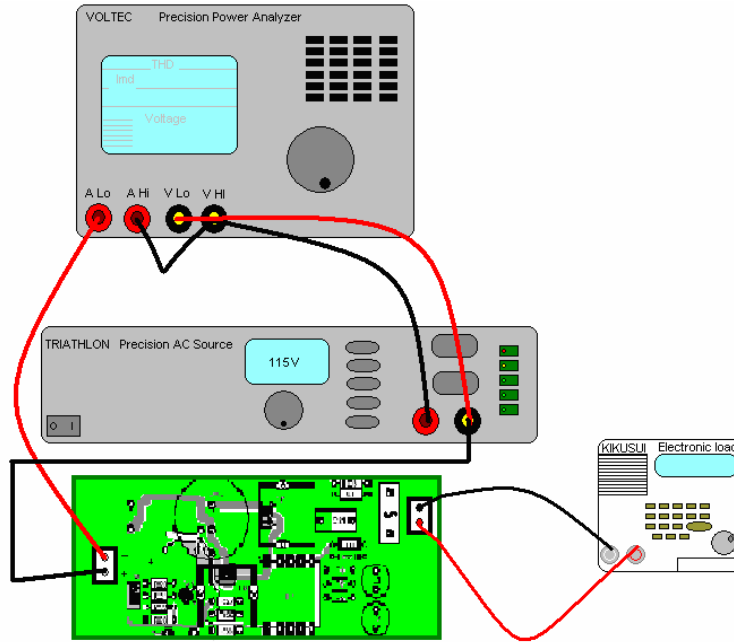

Figure 9. NCP1230GEVB Test Setup

Table 2. TEST EQUIPMENT

ac Source 85 – 265 Vac, 47 – 64 Hz	Variable Electronic Load
Digital Multimeter	Voltec Precision Power Analyzer

Test Setup

1. Connect the ac source to the input terminals J4.
2. Connect a variable electronic load to the output terminals J2, the PWB is marked +, for the positive output, and – for the return.
3. Set the variable electronic load to 45 W.
4. Turn on the ac source and set it to 115 Vac at 60 Hz.
5. Verify that the NCP1230 provides 19 Vdc to the load.
6. Vary the load and input voltage. Verify that the output voltage is within the minimum and maximum values as shown in Table 4.
7. To verify total harmonic distortion (THD) first, shut off the ac power supply.

8. Connect the Voltec Precision Power Analyzer as shown in Figure 9.
9. Turn on the ac source to 115 Vac at 60 Hz and set the electronic load to 90 W. (Only measure the THD at full load).
10. Verify that the current Harmonics (THD) are less than the maximum vales in Table 5.
11. Verify that the PF is greater than the minimum values in Table 5.
12. Set the ac source output to 230 Vac at 60 Hz.
13. Verify that the current Harmonics (THD) are less than the maximum vales in Table 5.
14. Verify that the PF is greater than the minimum values in Table 5.
15. Set the ac source to 115 Vac, set the load to 0 Adc, and measure the standby power, refer to Table 5 for the maximum acceptable input power.
16. Set the ac source to 230 Vac, and refer to Table 5 for the maximum input power.

Table 3. EXPECTED VALUES FOR VARYING INPUT VOLTAGES AND LOADS

Vin (Vac)	Vo (Vdc) @ No Load	Vo (Vdc) @ 45 W	Vo (Vdc) @ 90 W	THD (%)	PF 90 W
90	19.1	19.0	18.8	6.5	0.995
115	19.1	19.0	18.8	7.8	0.995
230	18.7	19.1	18.8	20	0.97

Table 3 shows typical values, the initial set point (19.0 Vdc may vary).

NCP1230GEVB

Table 4. REGULATION

Vin (Vac)	Pinmax (W)	Vomin (Vdc)	Vomax (Vdc)	IO (Adc)	Po (W)	Eff (%)
90	115	18.7	19.1	4.85	90	80.0
115	114	18.7	19.1	4.85	90	80.0
230	112	18.7	19.1	4.85	90	81.0

Table 5. STAND-BY POWER

Vin (Vac)	Pinmax (mW)
115	150
230	200

Table 6. POWER FACTOR AND THD

Vin (Vac)	PFmin (W)	THDmax (%)	PO (W)
90	0.990	8.0	90
115	0.990	9.0	90
230	0.96	21.0	90

Figure 10. NCP1230 Demo Board Schematic – PFC section

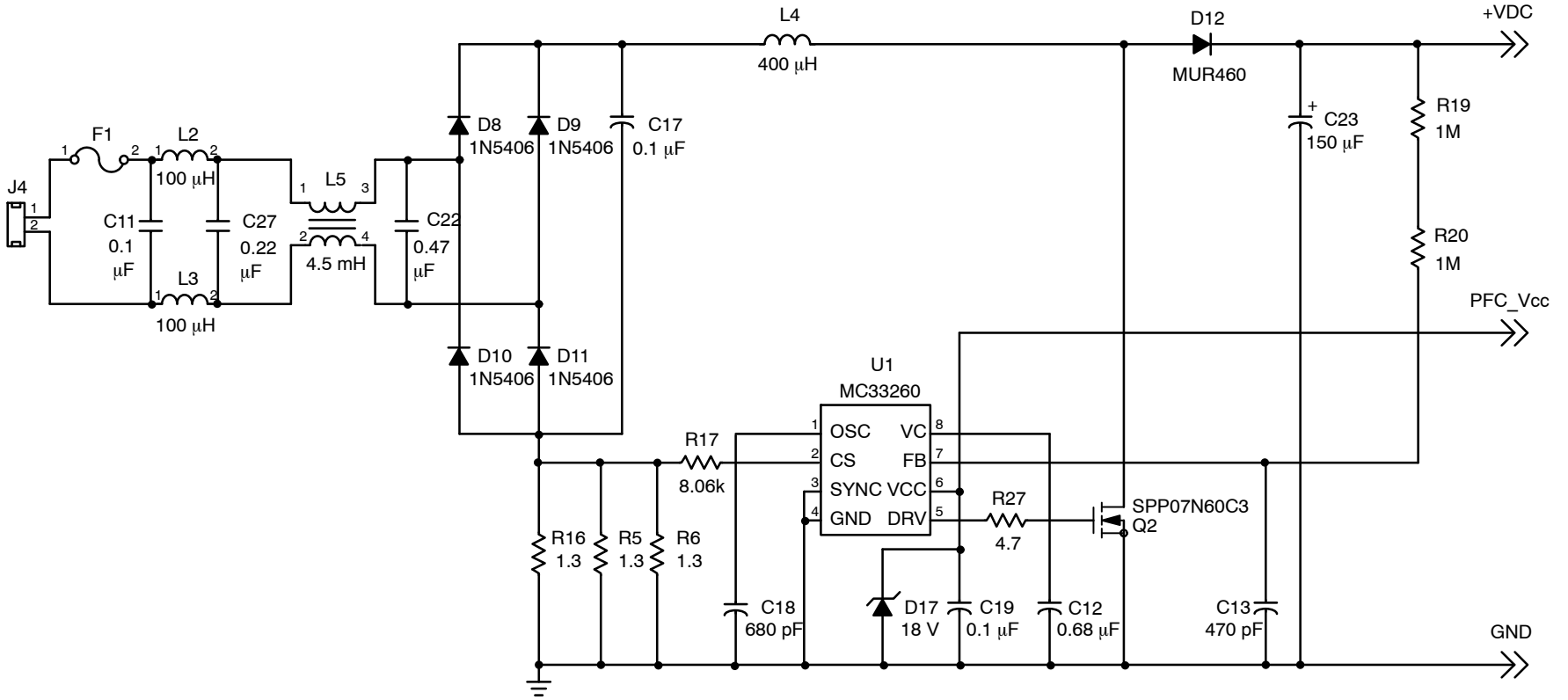

NCP1230GEVB

Table 7. Voltage Regulation and Efficiency

Vin (Vac)	Pin (W)	Vo (Vdc)	Io (A dc)	Po (W)	Eff (%)
85	54.50	19.02	2.36	45	82.57
115	54.40	19.03	2.36	45	82.72
230	53.21	19.06	2.36	45	84.54
265	53.1	19.06	2.36	45	84.71
85	112.00	18.82	4.77	90	80.36
115	110.84	18.88	4.77	90	81.2
230	109.42	18.88	4.77	90	82.25
265	109.01	18.89	4.77	90	82.56

Table 8. Power Factor and Distortion

Vin (Vac)	Pin (W)	PF	THD (%)	Vo (Vdc)	Po (W)
85	112.00	0.996	6.5	18.82	90
115	110.84	0.996	7.7	18.88	90
230	109.42	0.972	19.01	18.88	90
265	109.01	0.965	23.0	18.89	90

Table 9. Standby Power

Test	Condition (Vac input)	Requirement Pin (mW)	Pin Measured (mW)
Standby Power	230	150	120
Pin Short Circuit	230	100	100
Pin with 0.5 W Load	230	800	600

Table 10. Vendor Contact List

ON Semiconductor	www.onsemi.com 1-800-282-9855
TDK	www.component.tdk.com 1-847-803-6100
Infineon	www.infineon.com
Coilcraft	www.coilcraft.com
Vishay	www.vishay.com
Coiltronics	www.cooperet.com 1-888-414-2645
Bussman (Cooper Ind.)	www.cooperet.com 1-888-414-2645
Panasonic	www.eddieray.com/panasonic.com
Weidmuller	www.weidmuller.com
Keystone	www.keyelco.com 1-800-221-5510
HH Smith	www.hhsmith.com 1-888-847-6484
Aavid Thermalloy	www.aavid.com

NCP1230GEVB

Table 11. NCP1230 EVALUATION BOARD BILL OF MATERIALS

Designator	QTY	Description	Value	Tolerance	Footprint	Manufacturer	Manufacturer Part Number	Substitution Allowed	RoHS Compliant
U9	1	Flyback Controller	18 V, 0.5 A	NA	SOIC 8	ON Semiconductor	NCP1230D65R2G	No	Yes
U2	1	PFC controller	16 V, 0.6 A	NA	SOIC 8	ON Semiconductor	MC33260DG	No	Yes
U12	1	Programable reference	2.5 V	NA	SOIC 8	ON Semiconductor	TL431ACDG	No	Yes
U4	1	Optocoupler	70 V, 50 Ma	NA	UL1577	Vishay	SFH615A-3	Yes	Yes
C1, C19	2	Ceramic chip capacitor	0.1 uF, 50 V	10%	0603	Vishay	VJ0603Y104KXAA	Yes	Yes
C2, C3, C14, C15	4	Electrolytic Capacitor	2200 uF, 25 V	20%	16.0 mm x 25.0 mm	Vishay	EKB00JG422F00	Yes	Yes
C5	1	Electrolytic Capacitor	100 uF, 35 V	20%	6.3 mm x 11.0 mm	Vishay	EKB00BA310F00	Yes	Yes
C6	1	Cap, Ceramic	0.01uF, 1000V	10%	Disc	Vishay	562RZ5UBA102E103M	Yes	Yes
C7, C8	2	Cap. Aluminum Elec	47 uF, 25 V	20%	5.0 mm x 11.0 mm	Vishay	EKB00AA247F00	Yes	Yes
C10	1	Capacitor, Y2 class	2.2 nF, 250 V	20%	5.3 mm x 10.3 mm	Vishay	F1710-222-1000	Yes	Yes
C11, C17	2	Capacitor, X2 class	0.1 uF, 300 V	10%	8.3 mm x 17.8 mm	Vishay	F1772-410-3000	Yes	Yes
C12	1	Ceramic chip capacitor	0.068 uF, 50 V	10%	0603	Vishay	VJ0603Y683KXAA	Yes	Yes
C13	1	Ceramic chip capacitor	470 pF, 50 V	10%	0603	Vishay	VJ0603471KXAA	Yes	Yes
C18	1	Ceramic chip capacitor	680 pF, 50V	10%	0603	Vishay	VJ0603Y681KXAA	Yes	Yes
C20	1	Cap. Ceramic, chip	0.047 uF, 16 V	10%	0805	Vishay	VJ0805Y473KXJA	Yes	Yes
C22	1	Capacitor, X2 class	0.47 uF, 300 V	10%	13.0 mm x 31.3 mm	Vishay	F1772-447-3000	Yes	Yes
C23	1	Cap. Aluminum	150uF, 450Vdc	20%	25mm x 40mm	Panasonic	ECOS2WP151CA	Yes	Yes
C24	1	Ceramic chip capacitor	100 pF, 50 V	10%	0805	Vishay	VJ0805100KXAA	Yes	Yes
C25	1	Ceramic chip capacitor	1.0 nF, 50 V	10%	0805	Vishay	VJ0805Y102KXAA	Yes	Yes
C27	1	Capacitor, X2 class	0.22 uF, 300 V	10%	10.3 mm x 26.3 mm	Vishay	F1772-422-3000	Yes	Yes
D1	1	Zener Diode, SM	13 V, 0.3 W	NA	SOT-23	Vishay	AZ23C13	Yes	Yes
D2, D16	2	Diode, signal	75V, 100ma	NA	SOT-23	ON Semiconductor	BAS19LT1G	No	Yes
D4	1	Diode, ultra fast	600 V, 1 A	NA	DO41	ON Semiconductor	MUR160	No	Yes
D8, D9, D10, D11	4	Diode, rectifier	1000 V, 3 A	NA	DO201AD	ON Semiconductor	1N5408G	No	Yes
D12	1	Diode, ultra-fast	600 V, 4 A	NA	DO201AD	ON Semiconductor	MUR460	No	Yes
D13, D15	2	Diode, rectifier	800 V, 1 A	NA	DO41	ON Semiconductor	1N4006	No	Yes
D17, D18	2	Zener Diode, SM	18 V, 0.3 W	NA	SOT-23	Vishay	AZ23C18	Yes	Yes

NCP1230GEVB

Table 11. NCP1230 EVALUATION BOARD BILL OF MATERIALS

Designator	QTY	Description	Value	Tolerance	Footprint	Manufacturer	Manufacturer Part Number	Substitution Allowed	RoHS Compliant
D19	1	Diode, schottky	100 V, 20 A	NA	TO220AB	ON Semiconductor	MBR20100CTG	No	Yes
F1	1	Brick Fuse	250 Vac, 2 A	NA	10mm x 2.5mm	Bussman	1025TD2	Yes	Yes
J2, J4	2	PCB Connector	10 A, 300 V	NA	5.08 mm	Weidmuller	171602	Yes	Yes
L1	1	Inductor	2.2 uH, 7.5 A	10%	13 mm x 9 mm	Coilcraft	DO3316P-222ML	Yes	Yes
L2, L3	2	Inductor	100 uH, 2.5 A	10%	1315	TDK	TSL1315-101K2R5	Yes	Yes
L4	1	PFC Inductor	400 uH, 5 A	20%	NA	Cooper Electronics	CTX22-16816	Yes	Yes
L5	1	Common Mode Inductor	508 uH, 3 A	30%	NA	Coilcraft	E3506-AL	Yes	Yes
Q1	1	MOSFET 0.8 Ω	800 V, 11 A	NA	TO220-31	Infineon	SPP11N80C3	Yes	Yes
Q2	1	MOSFET 0.8 Ω	650 V, 7.3 A	NA	TO220-31	Infineon	SPP07N60C3	Yes	Yes
Q3	1	Bipolar transistor	60 V, 0.6 A	NA	SOT-23	ON Semiconductor	MMBT2907ALT1G	No	Yes
R1, R3	2	Resistor	0.4 Ω, 1 W	1%	2512	Vishay	WSL2512R4000FEA	Yes	Yes
R2, R18, R29	3	Resistor	100k, 3W	5%	14.10 mm x 4.57 mm	Vishay	CPF3100k00JNE14	Yes	Yes
R4	1	Resistor	49.9 kΩ, 1/8 W	1%	0805	Vishay	CRCW08054992FNEA	Yes	Yes
R5, R6, R16	3	Resistor	1.3 Ω, 1 W	1%	2512	Vishay	CRCW25121R30FNEA	Yes	Yes
R7	1	Resistor	4.7 kΩ, 1/8 W	5%	0805	Vishay	CRCW8054700RJNEA	Yes	Yes
R10	1	Resistor	7.42 kΩ, 1/8 W	1%	0805	Vishay	CRCW08057421FNEA	Yes	Yes
R13	1	Resistor	20 Ω, 1/4 W	5%	1206	Vishay	CRCW120620R0JNEA	Yes	Yes
R17	1	Resistor	8.06 kΩ, 1/8 W	1%	0805	Vishay	CRCW08058K06FKEA	Yes	Yes
R19, R20	2	Resistor	1 MΩ, 1/8 W	1%	6.10 mm x 2.29 mm	Vishay	CMF551004FKEK	Yes	Yes
R21, R22	2	Resistor	1 kΩ, 1/4 W	1%	1206	Vishay	CRCW12061K00FKEA	Yes	Yes
R24	1	Jumper, 22 AWG	NA	NA	NA	Any	NA	Yes	Yes
R25	1	Resistor	200 Ω, 1/4 W	5%	1206	Vishay	CRCW1206200RJNEA	Yes	Yes
R26	1	Resistor	10 kΩ, 1/4 W	5%	1206	Vishay	CRCW120610K0JNEA	Yes	Yes
R27	1	Resistor	4.7 Ω, 1/4 W	5%	1206	Vishay	CRCW12064R7JNEA	Yes	Yes
R28	1	Resistor	200 Ω, 1/4 W	5%	1206	Vishay	CRCW1206200RJNEA	Yes	Yes
T1	1	Flyback Transformer	220 uH, 3.3 Apk	NA	NA	Cooper Electronics	CTX22-16134	Yes	Yes
H1	1	Shoulder Washer	NA	NA	#4 x 0.031"	Keystone	3049	Yes	Yes
H2	1	Insulator	NA	NA	0.86" x 0.52"	Keystone	4672	Yes	Yes
H3, H4, H5	3	Heatsink	NA	NA	TO-220	Aavid	590302B03600	Yes	Yes

NCP1230GEVB

ON Semiconductor and  are registered trademarks of Semiconductor Components Industries, LLC (SCILLC). SCILLC owns the rights to a number of patents, trademarks, copyrights, trade secrets, and other intellectual property. A listing of SCILLC's product/patent coverage may be accessed at www.onsemi.com/site/pdf/Patent-Marking.pdf. SCILLC reserves the right to make changes without further notice to any products herein. SCILLC makes no warranty, representation or guarantee regarding the suitability of its products for any particular purpose, nor does SCILLC assume any liability arising out of the application or use of any product or circuit, and specifically disclaims any and all liability, including without limitation special, consequential or incidental damages. "Typical" parameters which may be provided in SCILLC data sheets and/or specifications can and do vary in different applications and actual performance may vary over time. All operating parameters, including "Typicals" must be validated for each customer application by customer's technical experts. SCILLC does not convey any license under its patent rights nor the rights of others. SCILLC products are not designed, intended, or authorized for use as components in systems intended for surgical implant into the body, or other applications intended to support or sustain life, or for any other application in which the failure of the SCILLC product could create a situation where personal injury or death may occur. Should Buyer purchase or use SCILLC products for any such unintended or unauthorized application, Buyer shall indemnify and hold SCILLC and its officers, employees, subsidiaries, affiliates, and distributors harmless against all claims, costs, damages, and expenses, and reasonable attorney fees arising out of, directly or indirectly, any claim of personal injury or death associated with such unintended or unauthorized use, even if such claim alleges that SCILLC was negligent regarding the design or manufacture of the part. SCILLC is an Equal Opportunity/Affirmative Action Employer. This literature is subject to all applicable copyright laws and is not for resale in any manner.

PUBLICATION ORDERING INFORMATION

LITERATURE FULFILLMENT:

Literature Distribution Center for ON Semiconductor
P.O. Box 5163, Denver, Colorado 80217 USA
Phone: 303-675-2175 or 800-344-3860 Toll Free USA/Canada
Fax: 303-675-2176 or 800-344-3867 Toll Free USA/Canada
Email: orderlit@onsemi.com

N. American Technical Support: 800-282-9855 Toll Free
USA/Canada
Europe, Middle East and Africa Technical Support:
Phone: 421 33 790 2910
Japan Customer Focus Center
Phone: 81-3-5817-1050

ON Semiconductor Website: www.onsemi.com
Order Literature: <http://www.onsemi.com/orderlit>
For additional information, please contact your local
Sales Representative