



Chipsmall Limited consists of a professional team with an average of over 10 year of expertise in the distribution of electronic components. Based in Hongkong, we have already established firm and mutual-benefit business relationships with customers from,Europe,America and south Asia,supplying obsolete and hard-to-find components to meet their specific needs.

With the principle of “Quality Parts,Customers Priority,Honest Operation,and Considerate Service”,our business mainly focus on the distribution of electronic components. Line cards we deal with include Microchip,ALPS,ROHM,Xilinx,Pulse,ON,Everlight and Freescale. Main products comprise IC,Modules,Potentiometer,IC Socket,Relay,Connector.Our parts cover such applications as commercial,industrial, and automotives areas.

We are looking forward to setting up business relationship with you and hope to provide you with the best service and solution. Let us make a better world for our industry!



Contact us

Tel: +86-755-8981 8866 Fax: +86-755-8427 6832

Email & Skype: info@chipsmall.com Web: www.chipsmall.com

Address: A1208, Overseas Decoration Building, #122 Zhenhua RD., Futian, Shenzhen, China



NCP1406, NCV1406

25 V/25 mA PFM Step-Up DC-DC Converter

The NCP1406 is a monolithic step-up DC-DC converter operating in a Pulse Frequency Modulation (PFM) scheme with constant peak current control. It integrates a 0.8 A, 0.7 Ω internal power switch and sensing resistor to monitor inductor current. This control scheme maintains high efficiencies over the entire load current range. The wide input voltage range, from 1.4V to 5.5 V, enables the user to operate the device from a Li-Ion battery or a two-cell Alkaline NiMH. Its ability to boost voltages up to 25 V, and to provide 1 W output power, makes the NCP1406 the perfect solution for biasing small and large OLED panels. This device also makes a perfect solution for biasing a great number of white LEDs in series. A Chip Enable pin allows the user to control the device to extend the battery life during standby, and can be pulse-width modulated for white LED applications. The versatility of the NCP1406 allows it to be configured not only as a step-up converter, but also as an inverter and as a step-down converter. This solution is proposed in a space-saving TSOP-5 package.

Features

- 87% Efficiency at $V_{OUT} = 25$ V, $I_{OUT} = 25$ mA, $V_{IN} = 5$ V
- Adjustable Output Voltage up to 25 V
- 0.8 A, 26 V Internal Power Switch
- Operating Input Voltage from 1.4 V to 5.5 V
- Low Startup Voltage of 1.8 V Typical at No Load
- Low Operating Current of 15 μ A (Not Switching)
- Low Shutdown Current of 0.3 μ A
- Operating Switching Frequency up to 1 MHz
- Output Voltage Soft-Start
- Thermal Shutdown Protection
- These are Pb-Free Devices
- NCV Prefix for Automotive and Other Applications Requiring Unique Site and Control Change Requirements; AEC-Q100 Qualified and PPAP Capable

Typical Applications

- LCD Bias Supplies
- Small and Large OLED Display Drivers
- White LED Driver for Backlight Displays
- Personal Digital Assistants (PDA)
- Portable Applications:
 - ♦ Cell Phones, Digital Cameras
 - ♦ PDAs, Games, and Portable Video Players



ON Semiconductor®

<http://onsemi.com>

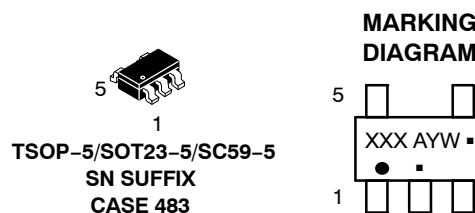

DAM = Device Marking - NCP1406
AET = Device Marking - NCV1406
A = Assembly Location
Y = Year
W = Work Week
▪ = Pb-Free Package

(Note: Microdot may be in either location)

PIN CONNECTIONS

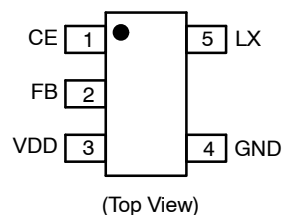

ORDERING INFORMATION

Device	Package	Shipping†
NCP1406SNT1G	TSOP-5 (Pb-Free)	3000 Tape & Reel
NCV1406SNT1G	TSOP-5 (Pb-Free)	3000 Tape & Reel

†For information on tape and reel specifications, including part orientation and tape sizes, please refer to our Tape and Reel Packaging Specification Brochure, BRD8011/D.

NCP1406, NCV1406

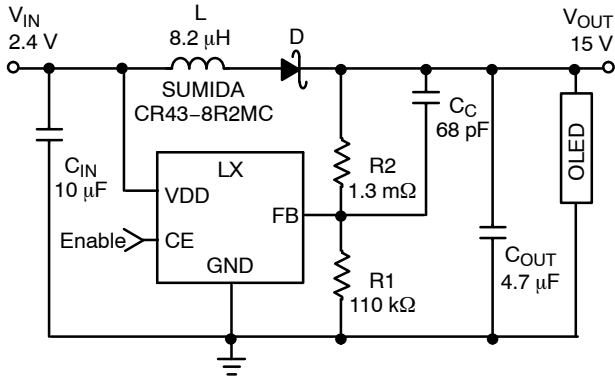

Figure 1. Typical Application Circuit

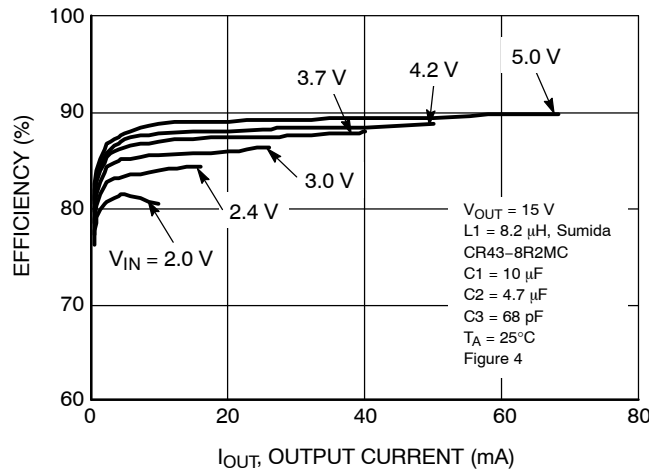

Figure 2. Efficiency versus Output Current

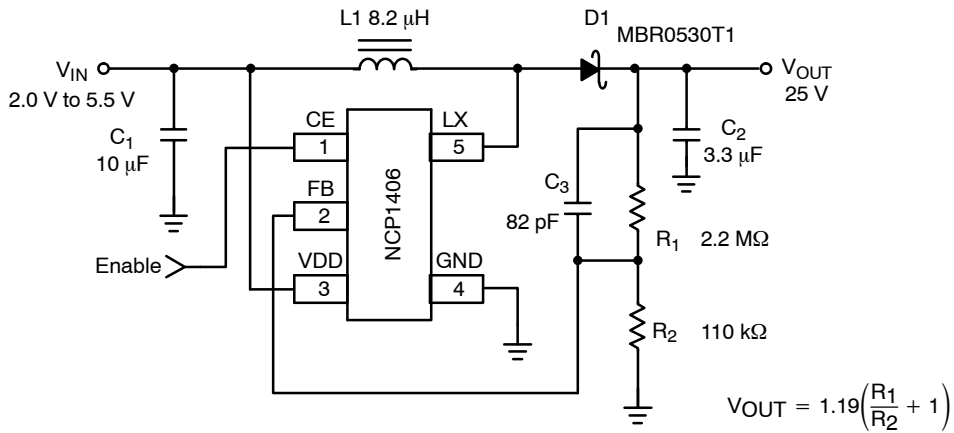

Figure 3. Typical 25 V Step-Up Application Circuit

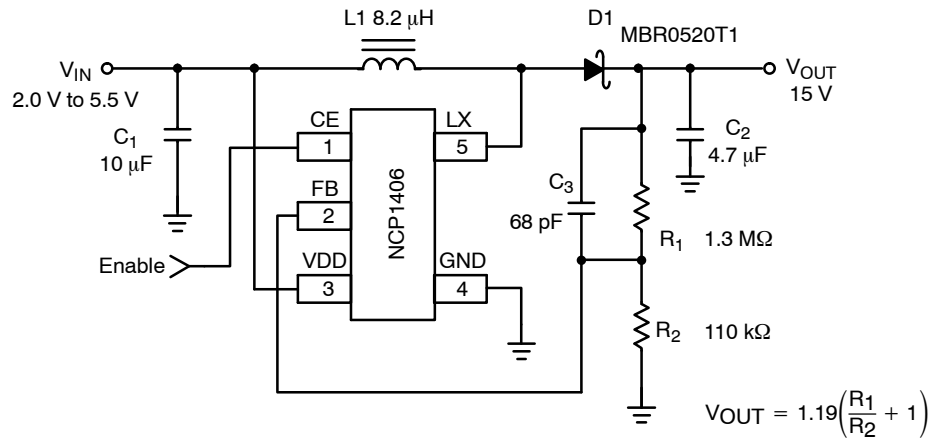

Figure 4. Typical 15 V Step-Up Application Circuit

NCP1406, NCV1406

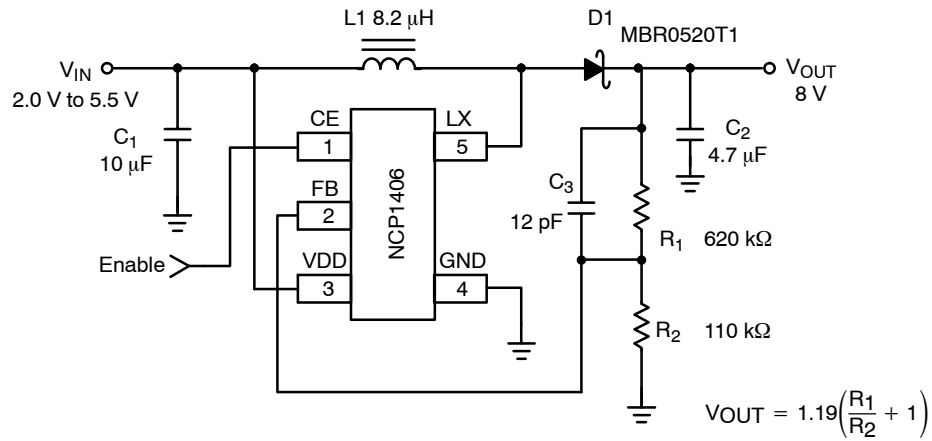

Figure 5. Typical 8 V Step-Up Application Circuit

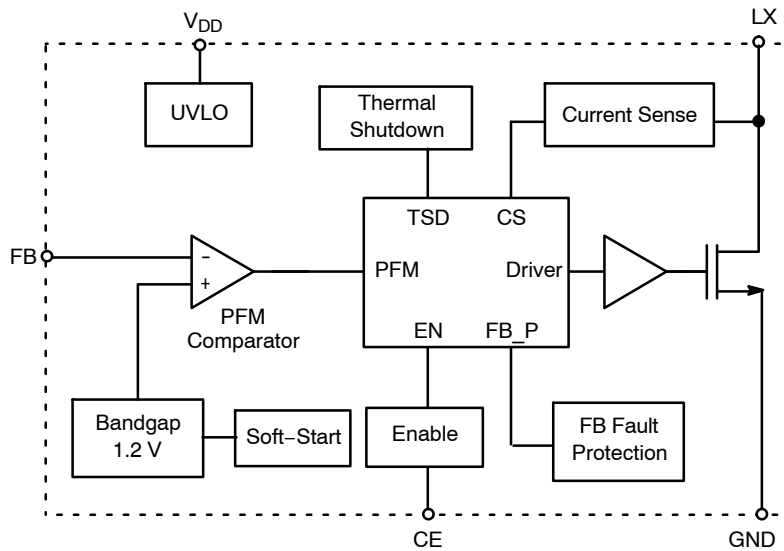

Figure 6. Representative Block Diagram

PIN FUNCTION DESCRIPTION

Pin	Symbol	Description
1	CE	Chip Enable Pin (1) The chip is enabled if a voltage which is equal to or greater than 0.9 V is applied. (2) The chip is disabled if a voltage which is less than 0.3 V is applied. (3) The chip will be enabled if it is left floating.
2	FB	Output feedback voltage. Connected to the inverting input of the PFM comparator.
3	VDD	Power supply pin for internal circuit
4	GND	Analog and power ground pin
5	LX	External inductor connection pin. Connected to the drain of the NMOS internal switch.

NCP1406, NCV1406

MAXIMUM RATINGS

Rating	Symbol	Value	Unit
Power Supply Voltage (Pin 3)	V_{DD}	-0.3 to 6.0	V
Input/Output Pin LX (Pin 5)	V_{LX}	-0.3 to 27	V
LX Peak Sink Current	I_{LX}	1.5	A
FB (Pin 2)	V_{FB}	-0.3 to 6.0	V
CE (Pin 1) Input Voltage Range	V_{CE}	-0.3 to 6.0	V
Power Dissipation and Thermal Characteristics Maximum Power Dissipation @ $T_A = 25^\circ\text{C}$ Thermal Resistance, Junction-to-Air	P_D $R_{\theta JA}$	500 250	mW $^\circ\text{C}/\text{W}$
Operating Ambient Temperature Range	T_A	-40 to +85 -40 to +105	$^\circ\text{C}$
	NCP1406 NCV1406		
Operating Junction Temperature Range	T_J	-40 to +150	$^\circ\text{C}$
Storage Temperature Range	T_{stg}	-55 to +150	$^\circ\text{C}$

Stresses exceeding Maximum Ratings may damage the device. Maximum Ratings are stress ratings only. Functional operation above the Recommended Operating Conditions is not implied. Extended exposure to stresses above the Recommended Operating Conditions may affect device reliability.

- This device series contains ESD protection and exceeds the following tests:
Human Body Model (HBM) ± 2.0 kV per JEDEC standard: JESD22-A114 for all pins
Machine Model (MM) ± 200 V per JEDEC standard: JESD22-A115 for all pins
- Latchup Current Maximum Rating: ± 150 mA per JEDEC standard: JESD78
- Moisture Sensitivity Level (MSL): 1 per IPC/JEDEC standard: J-STD-020A

DISSIPATION RATINGS

Package	Power Rating @ $T_A \leq 25^\circ\text{C}$	Derating Factor @ $T_A > 25^\circ\text{C}$	Power Rating @ $T_A = 70^\circ\text{C}$	Power Rating @ $T_A = 85^\circ\text{C}$	Power Rating @ $T_A = 105^\circ\text{C}$
TSOP-5	500 mW	4.0 mW/ $^\circ\text{C}$	320 mW	260 mW	180 mW

NCP1406, NCV1406

ELECTRICAL CHARACTERISTICS ($V_{OUT} = 25\text{ V}$, $T_A = -40^\circ\text{C}$ to $+85^\circ\text{C}$ (NCP1406), $T_A = -40^\circ\text{C}$ to $+105^\circ\text{C}$ (NCV1406) for min/max values, typical values are at $T_A = 25^\circ\text{C}$, unless otherwise noted.)

Characteristic	Symbol	Min	Typ	Max	Unit
ON/OFF TIMING CONTROL					
Minimum Off Time ($V_{DD} = 3.0\text{ V}$, $V_{FB} = 0\text{ V}$)	t_{off}	0.08	0.13	0.20	μs
Maximum On Time (Current Not Asserted)	t_{on}	0.58	0.90	1.40	μs
Maximum Duty Cycle	D_{MAX}	84	90	96	%
Minimum Startup Voltage ($I_{OUT} = 0\text{ mA}$)	V_{start}	-	1.8	2.0	V
Minimum Startup Voltage Temperature Coefficient ($T_A = -40$ to $+105^\circ\text{C}$)	ΔV_{start}	-	1.6	-	$\text{mV}/^\circ\text{C}$
Minimum Hold Voltage ($I_{OUT} = 0\text{ mA}$)	V_{hold}	-	1.7	1.9	V
Soft-Start Time	t_{SS}	-	3.0	8.0	ms

LX (PIN 5)

Internal Switch Voltage (Note 4) (Note 5)	V_{LX}	-	-	26	V
LX Pin On-State Resistance ($V_{LX} = 0.4\text{ V}$, $V_{DD} = 5.0\text{ V}$)	$R_{sw(on)}$	-	0.7	-	Ω
Current Limit (When I_{LX} reaches I_{LIM} , the LX switch is turned off by the LX switch protection circuit) (Note 5)	I_{LIM}	-	0.80	-	A
Off-State Leakage Current ($V_{LX} = 26\text{ V}$)	I_{LKG}	-	0.1	1.0	μA

CE (PIN 1)

CE Input Voltage ($V_{DD} = 3.0\text{ V}$, $V_{FB} = 0\text{ V}$) High State, Device Enabled Low State, Device Disabled	$V_{CE(high)}$ $V_{CE(low)}$	0.9 -	- -	- 0.3	V V
CE Input Current High State, Device Enabled ($V_{DD} = V_{CE} = 5.5\text{ V}$) Low State, Device Disabled ($V_{DD} = 5.5\text{ V}$, $V_{CE} = V_{FB} = 0\text{ V}$)	$I_{CE(high)}$ $I_{CE(low)}$	- -500	10 -150	500 -	nA nA

TOTAL DEVICE

Supply Voltage	V_{DD}	1.4	-	5.5	V
Undervoltage Lockout (V_{DD} Falling)	V_{UVLO}	-	1.0	1.3	V
Feedback Voltage $T_A = 25^\circ\text{C}$ $T_A = -40$ to $+105^\circ\text{C}$	V_{FB}	1.178 1.170	1.190 1.190	1.202 1.210	V
Feedback Pin Bias Current ($V_{FB} = 1.19\text{ V}$)	I_{FB}	-	15	45	nA
Operating Current 1 ($V_{FB} = 0\text{ V}$, $V_{DD} = V_{CE} = 3.0\text{ V}$, Maximum Duty Cycle)	I_{DD1}	-	0.7	1.5	mA
Operating Current 2 ($V_{DD} = V_{CE} = V_{FB} = 3.0\text{ V}$, Not Switching)	I_{DD2}	-	15	25	μA
Off-State Current ($V_{DD} = 5.0\text{ V}$, $V_{CE} = 0\text{ V}$)	I_{OFF}	-	0.3	1.3	μA
Thermal Shutdown (Note 5)	T_{SD}	-	140	-	$^\circ\text{C}$
Thermal Shutdown Hysteresis (Note 5)	T_{SDHYS}	-	10	-	$^\circ\text{C}$

4. Recommended maximum V_{OUT} up to 25 V.
5. Guaranteed by design, not tested.

TYPICAL CHARACTERISTICS

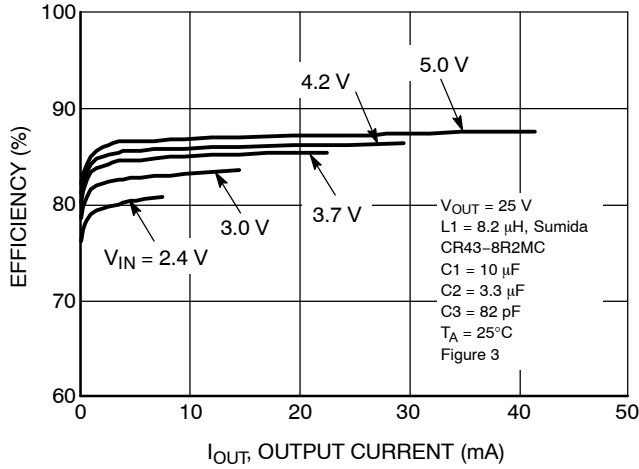

Figure 7. Efficiency versus Output Current ($V_{OUT} = 25\text{ V}$, $L = 8.2\ \mu\text{H}$)

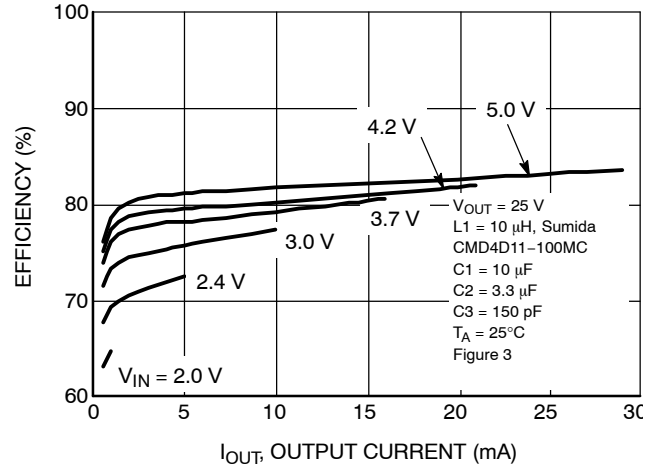

Figure 8. Efficiency versus Output Current ($V_{OUT} = 25\text{ V}$, $L = 10\ \mu\text{H}$)

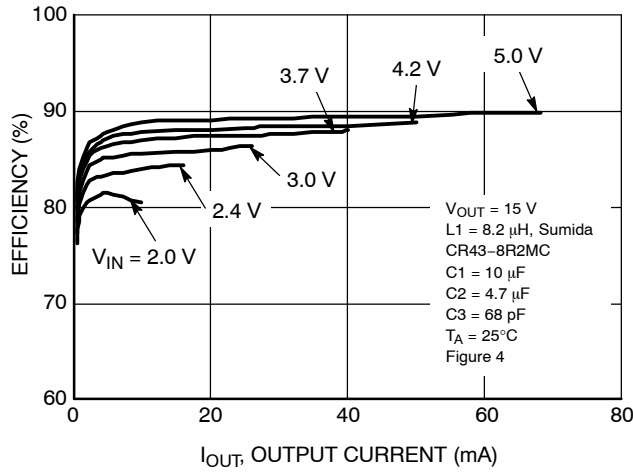

Figure 9. Efficiency versus Output Current ($V_{OUT} = 15\text{ V}$, $L = 8.2\ \mu\text{H}$)

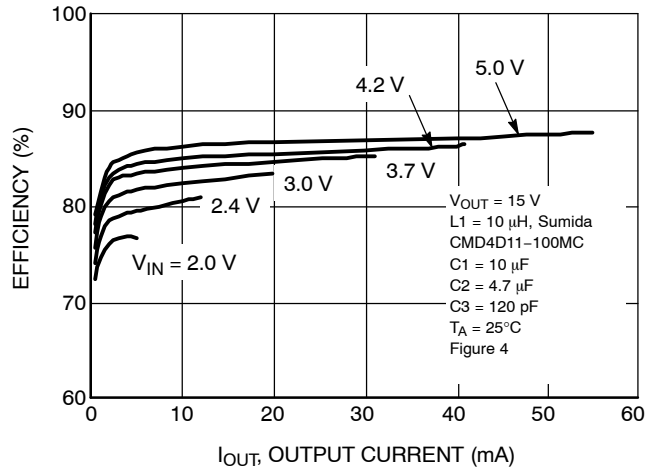

Figure 10. Efficiency versus Output Current ($V_{OUT} = 15\text{ V}$, $L = 10\ \mu\text{H}$)

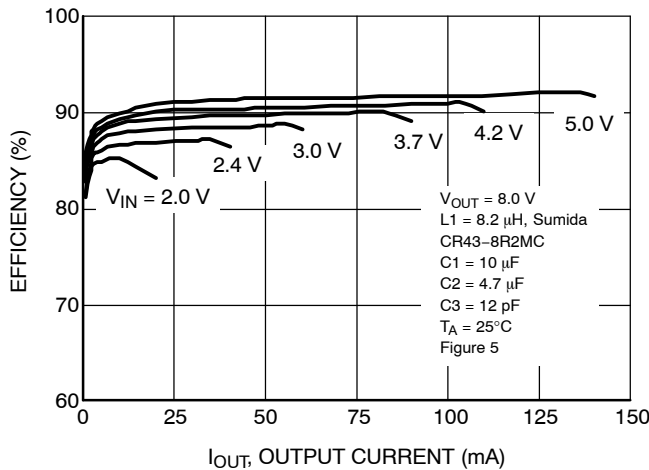

Figure 11. Efficiency versus Output Current ($V_{OUT} = 8\text{ V}$, $L = 8.2\ \mu\text{H}$)

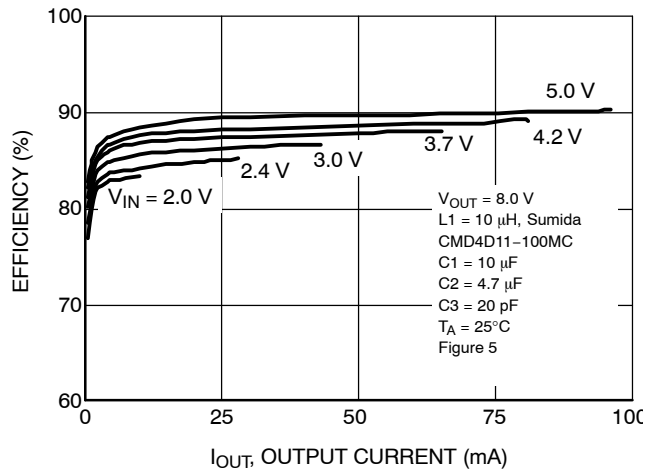

Figure 12. Efficiency versus Output Current ($V_{OUT} = 8.0\text{ V}$, $L = 10\ \mu\text{H}$)

TYPICAL CHARACTERISTICS

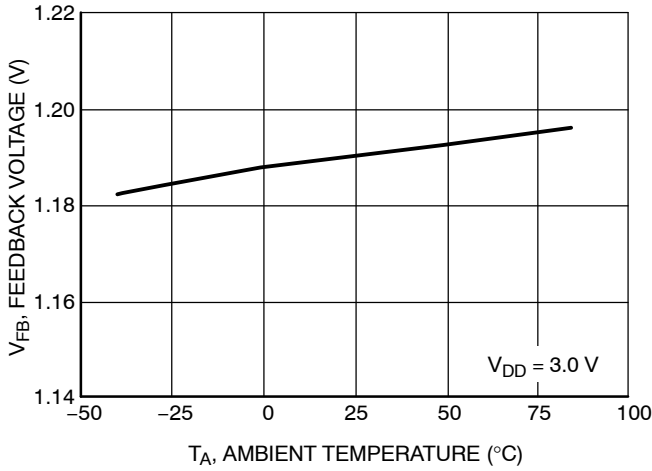

Figure 13. Feedback Voltage versus Ambient Temperature

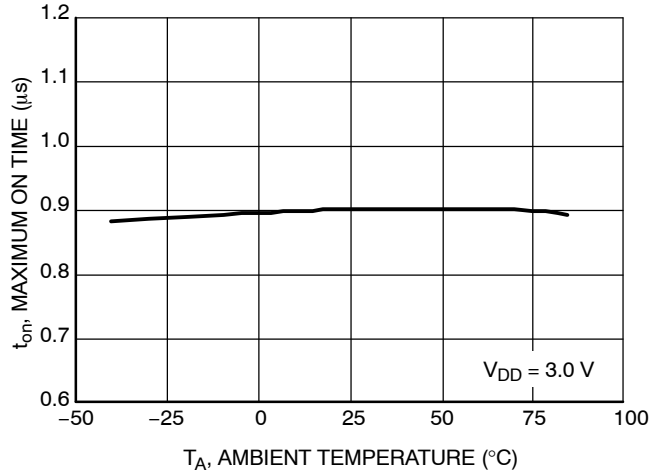

Figure 14. Maximum On Time versus Ambient Temperature

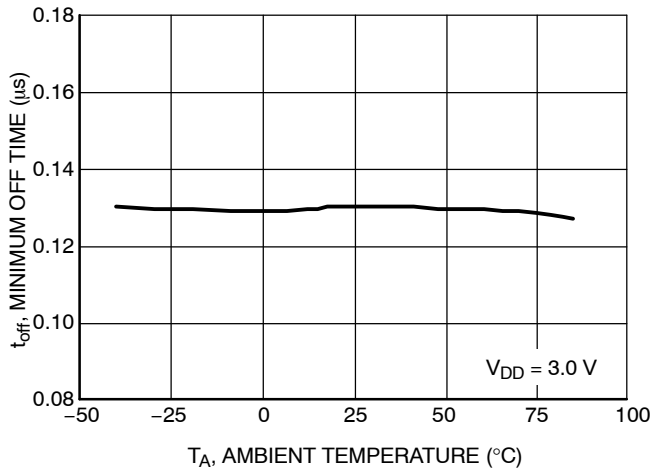

Figure 15. Minimum Off Time versus Ambient Temperature

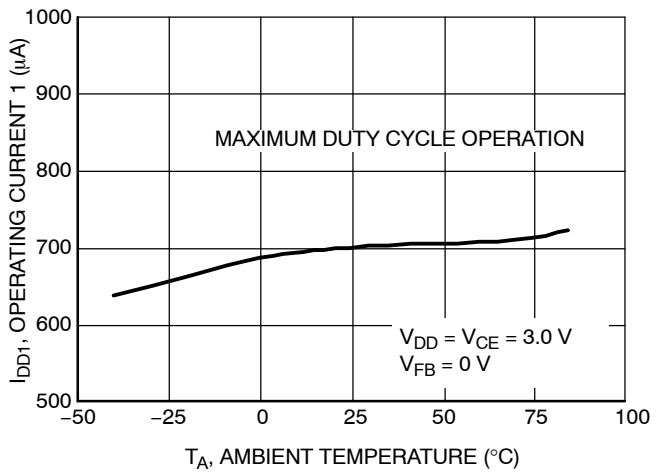

Figure 16. Operating Current 1 versus Ambient Temperature

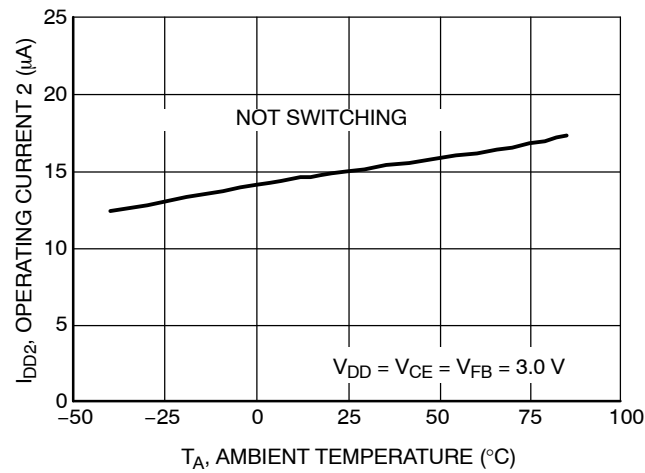

Figure 17. Operating Current 2 versus Ambient Temperature

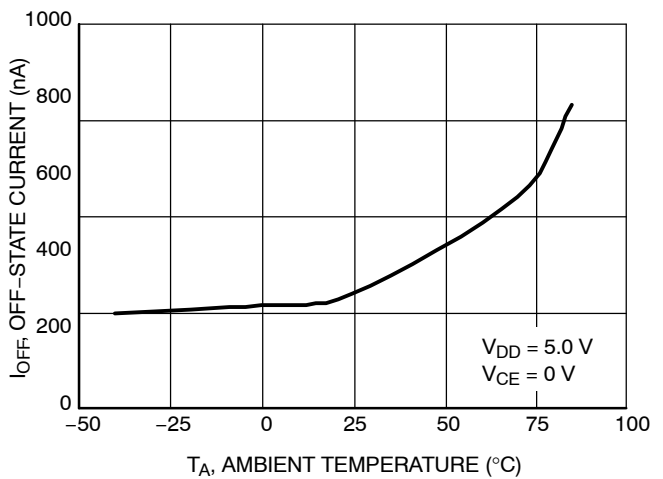

Figure 18. Off-State Current versus Ambient Temperature

TYPICAL CHARACTERISTICS

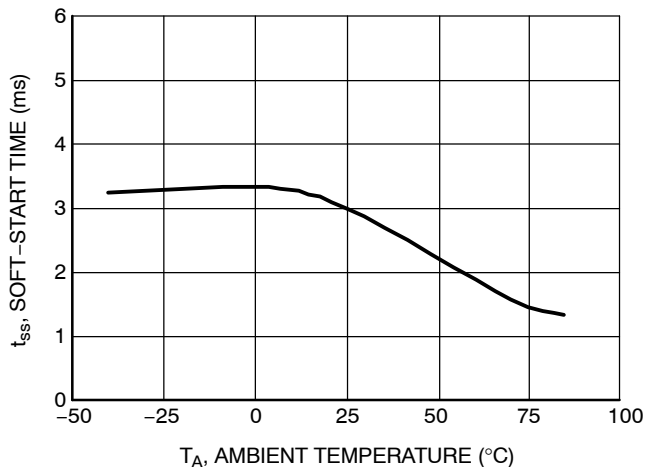

Figure 19. Soft-start Time versus Ambient Temperature

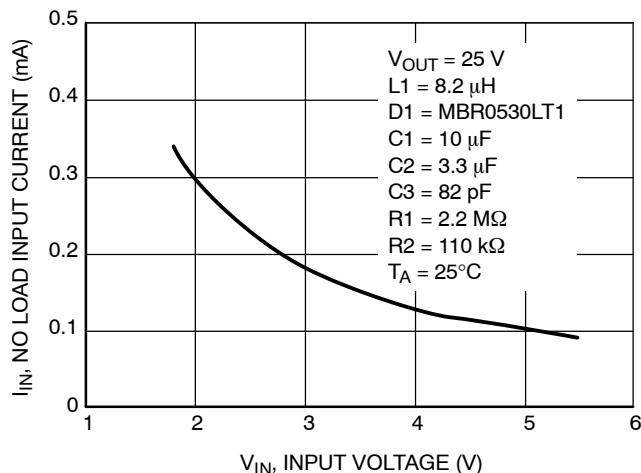

Figure 20. No Load Input Current versus Input Voltage

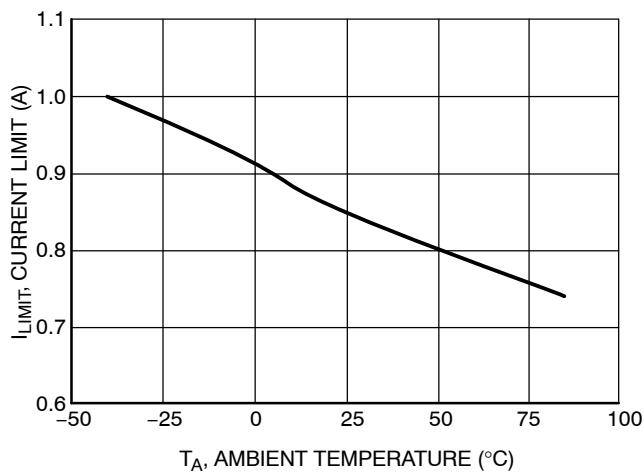

Figure 21. Current Limit versus Ambient Temperature

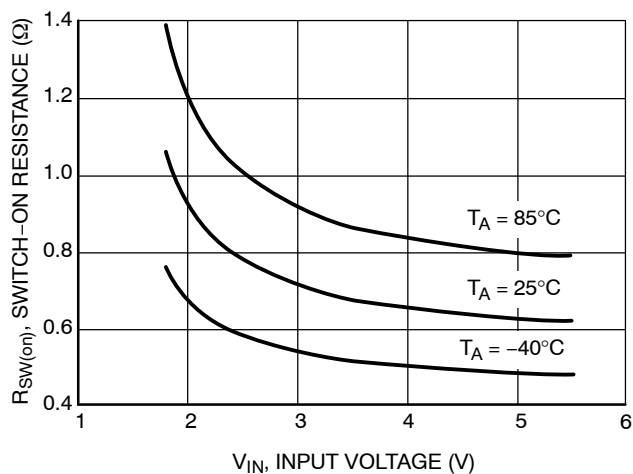
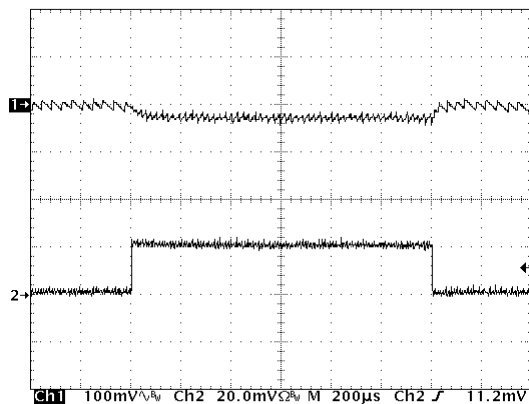
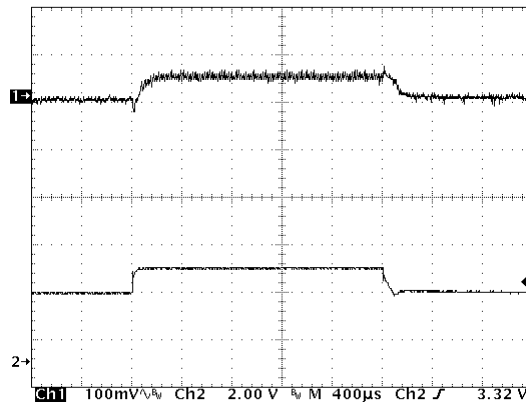

Figure 22. Switch-ON Resistance versus Input Voltage



L1 = 8.2 μ H, C1 = 10 μ F, C2 = 4.7 μ F, V_{IN} = 3.7 V
 1. V_{OUT} = 15 V (AC Coupled), 100 mV/div
 2. I_{OUT} = 1.0 mA to 20 mA, 20 mA/div

Figure 23. Load Transient Response (V_{OUT} = 15 V)



L1 = 8.2 μ H, C1 = 10 μ F, C2 = 4.7 μ F, I_{OUT} = 15 mA
 1. V_{OUT} = 15 V (AC Coupled), 100 mV/div
 2. V_{IN} = 3.0 V to 4.0 V, 2.0 V/div

Figure 24. Line Transient Response (V_{OUT} = 15 V)

TYPICAL CHARACTERISTICS

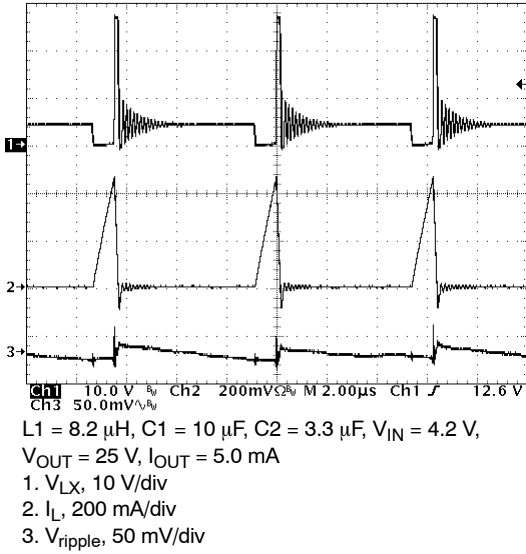

Figure 25. Operating Waveforms (Light Load)

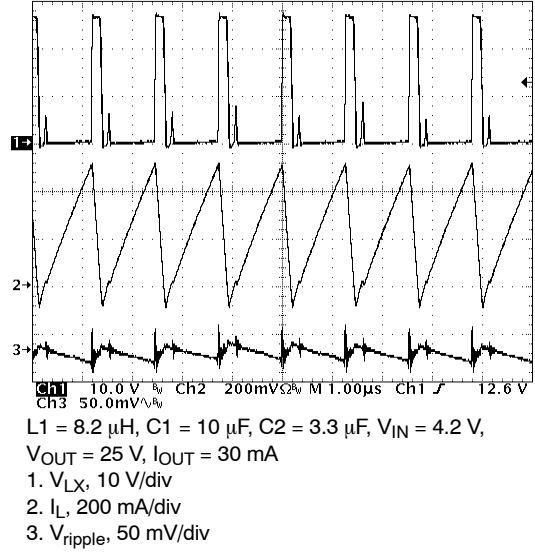

Figure 26. Operating Waveforms (Heavy Load)

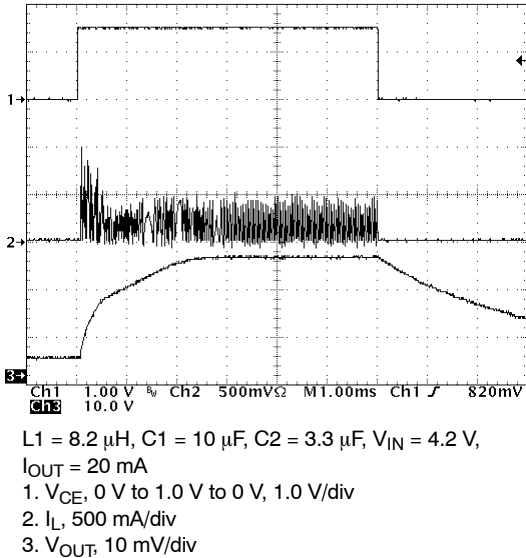

Figure 27. Startup/Shutdown Waveforms
($V_{OUT} = 25 \text{ V}$)

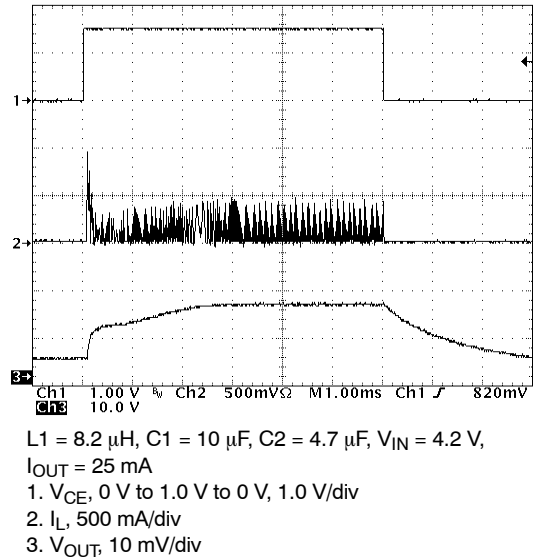

Figure 28. Startup/Shutdown Waveforms
($V_{OUT} = 15 \text{ V}$)

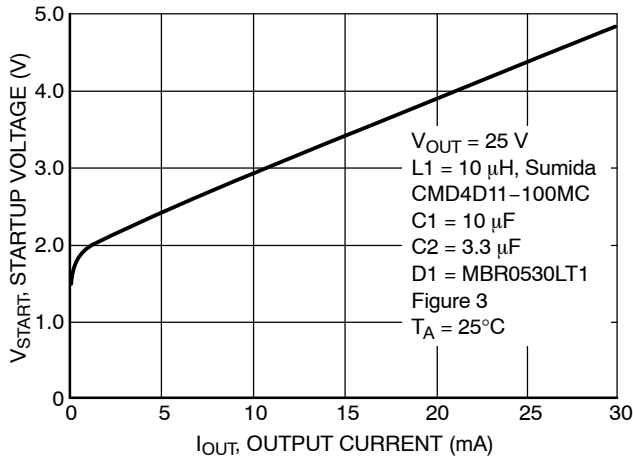

Figure 29. Startup Voltage versus Input Voltage
($V_{OUT} = 25 \text{ V}$)

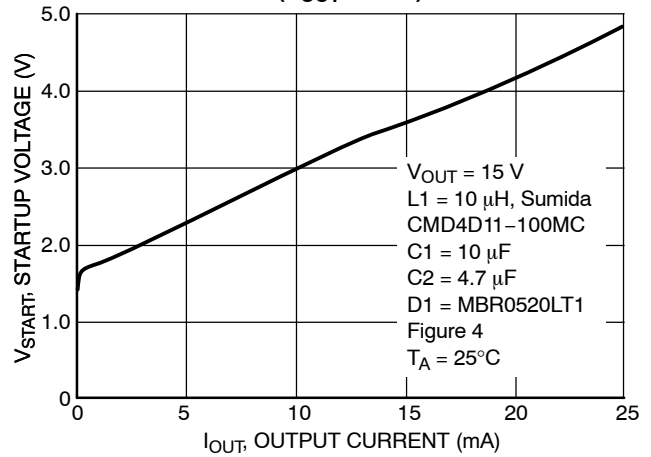

Figure 30. Startup Voltage versus Input Voltage
($V_{OUT} = 15 \text{ V}$)

SIMPLIFIED OPERATING DESCRIPTION

Operation

The NCP1406 is a monolithic DC-DC switching converter optimized for single Lithium, two- or three-cell AA/AAA size battery-powered portable products.

The NCP1406 operates in a Pulse Frequency Modulation (PFM) scheme with constant peak current control. This scheme maintains high efficiencies over the entire load current range.

The device is designed to operate in Discontinuous Conduction Mode (DCM). When the inductor releases its energy to the output and its current reaches zero before a new cycle starts, the converter is said to operate in DCM. If a new cycle starts before the inductor current reaches zero, the converter is said to operate in Continuous Conduction Mode (CCM).

The operation of the NCP1406 is not limited to the discontinuous conduction mode. The device can also be operated in continuous conduction mode, but its stability is not guaranteed.

Figure 31 depicts the three phases of operation in DCM in a simplified way. During the first interval, the switch is turned on and the diode is reverse biased. The inductor stores energy through the battery while the load is supplied by the output capacitor to maintain regulation. During the second interval, the switch is turned off and the diode is forward biased, this allows the energy stored in the inductor to be supplied to both the load and the capacitor. During the third interval, the switch is kept off and the diode is reverse biased, the capacitor supplies the current to the load.

In DCM, the voltage ratio can be expressed as:

$$\frac{V_{OUT}}{V_{IN}} = \frac{1 + \sqrt{1 + \frac{4 \times D^2}{K}}}{2} \quad (\text{eq. 1})$$

Where $D = \frac{T_{ON}}{T_{SW}}$, $KD = \frac{2 \times L \times I_{OUT}}{V_{OUT} \times T_{SW}}$

Unlike in CCM, the voltage ratio of a boost converter in DCM is load dependent.

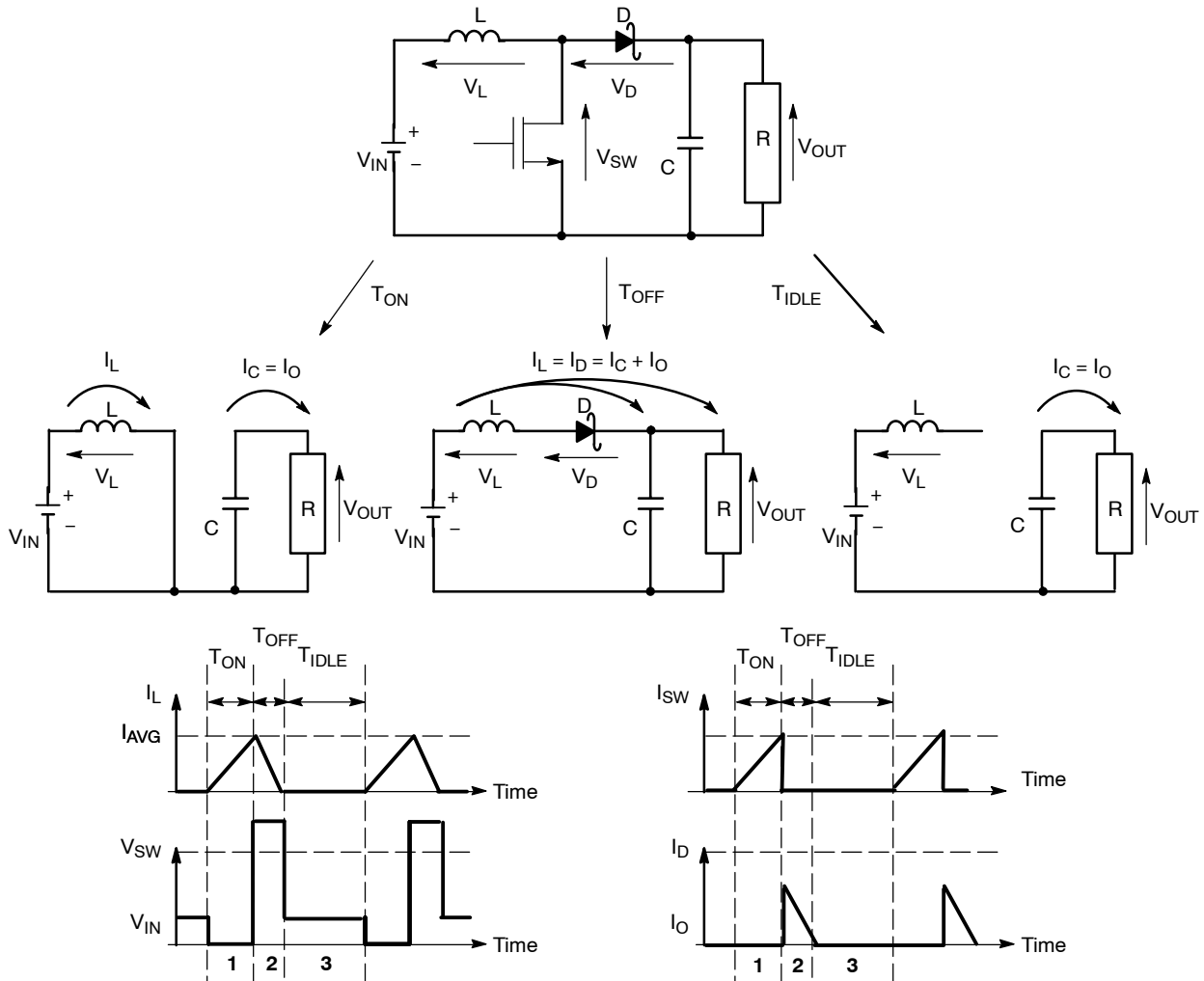

Figure 31. Simplified Boost Convertered Operation- Discontinuous Mode

The detailed operation of NCP1406 can be best understood by referring to the block diagram and typical application circuits in Figures 1, 3, 4, and 5. The PFM comparator monitors the output voltage via the external feedback resistor divider by comparing the feedback voltage with the reference voltage. When the feedback voltage is lower than the reference voltage, the PFM controller and driver circuit turn the internal switch on and the current ramps up in the inductor. The switch will remain on for the maximum on-time, 0.90 μ s, or until the current limit is reached (0.8 A), whichever occurs first. The internal switch is then turned off and the inductor current ramps down. The energy stored in the inductor will be discharged to the output capacitor and load through the Schottky diode. The internal switch will be turned off for at least the minimum off-time, 0.13 μ s, and will remain off until the feedback voltage becomes lower than the reference voltage. If the inductor current reaches zero before then, the Schottky diode will be reverse biased and the output capacitor will sustain the regulation by providing current to the load, while the switch pin will be left floating. The switch will turn back on when the feedback voltage becomes again lower than reference voltage. This switching cycle is then repeated to attain voltage regulation. The device operating current is typically 15 μ A (not switching), and can be further reduced to about 0.3 μ A when the chip is disabled ($V_{CE} < 0.3$ V).

Soft Start

There is a soft start circuit in NCP1406. When power is applied to the device, the soft-start circuit limits the device to switch at a small duty cycle initially. The duty cycle is then increased gradually until the output voltage is in regulation. With the soft-start circuit, the output voltage over-shoot is minimized and the startup capability with heavy loads is also improved.

ON/OFF Timing Control

The timing control of the converter is application dependent. The maximum on-time (inductor current ramping up) is set at a typical 0.9 μ s if the inductor current does not reach current limit 0.8 A. The minimum off-time (inductor current ramping down) is set at a typical 0.13 μ s to ensure the complete energy transfer to the output. The switching frequency can be as high as 1.0 MHz.

Voltage Reference and Output Voltage

The internal bandgap voltage reference is trimmed to 1.19 V with an accuracy of $\pm 1.0\%$ at 25°C. The voltage reference is connected to the non inverting input of the PFM comparator and the inverting input of the PFM comparator is connected to the FB pin. The output voltage can be set by connecting an external resistor divider to the output and using the FB pin. The output voltage programmable range is from V_{IN} to 25 V.

Current Limit

The current limit circuit limits the maximum current flowing through the LX pin to a typical of 0.8 A during the internal switch turn-on period. When the current limit is exceeded, the switch will be turned off. Since the peak inductor current is limited to the current limit, saturation of inductor is prevented and output voltage over-shoot during startup is also minimized.

Internal Switch

The NCP1406 integrates a 26 V open drain internal switch which allows high output voltage up to 25 V to be generated from simple step-up topology.

FB Pin Short-Circuit/Open-Circuit Protection

The FB protection circuit is realized by sensing the drain-to-source leakage current of the N-Ch MOSFET. When the FB pin connection is shorted or opened, the converter switches at maximum duty cycle, the peak of V_{LX} and the V_{OUT} will build up, and the leakage current will increase. When the leakage current increases to a certain level, the protection circuitry will trigger and the converter will stop switching. Therefore, the peak of V_{LX} will immediately stop increasing at a certain level before the N-Ch MOSFET is damaged. However, the sensing of the leakage current is not very accurate and cannot be too close to the normal 26 V maximum operating condition. Therefore, the V_{LX} is around 30 V to 40 V during a FB pin protection fault. This is not destructive to the chip though.

Input Undervoltage Lockout

An undervoltage lockout circuit continuously monitors the voltage at the VDD pin. The device will be disabled if the VDD pin voltage drops below the UVLO threshold voltage. In the same manner, the device will be enabled if the VDD pin voltage goes above the UVLO threshold.

Thermal Shutdown

When the chip junction temperature exceeds 140°C, the entire IC is shutdown. The IC will resume operation when the junction temperature drops below 130°C.

Enable/Disable Operation

An external pin, CE, allows the user to enable or disable the converter. This feature proves useful when the system is in a standby mode by increasing battery life through significantly decreased current consumption. A 150 nA pull-up current source ties the CE pin to the VDD pin internally. Therefore, leaving the CE pin floating will enable the NCP1406.

With no other connections to the CE pin, it can be independently controlled by an external signal. When the voltage at the CE pin is equal to or greater than 0.9 V, the chip will be enabled, which means the device is in normal operation. When the voltage at the CE pin is less than 0.3 V,

the chip is disabled and is shutdown. During shutdown, the IC supply current reduces to 0.3 μ A and the LX pin enters high impedance state. However, the input remains connected to the output through the inductor and the Schottky diode, keeping the output voltage one diode forward voltage drop below the input voltage.

When the NCP1406 is used to drive white LEDs, the EN pin can be pulse width modulated to control LED brightness.

External Component Selection

Inductor

Because it uses a PFM peak current control scheme in DCM, the NCP1406 is inherently stable. The inductor value does not affect the stability of the device. The NCP1406 is designed to work well with a range of inductance values; the actual inductance value depends on the specific application, output current, efficiency, and output ripple voltage. For step-up conversion, the device works well with inductance ranging from 1 μ H to 47 μ H. The selection of the inductor value along with the load current, input and output voltages determines the switching frequency at which the converter will operate.

In general, an inductor with small DCR is used to minimize loss and increase efficiency. It is necessary to choose an inductor with saturation current greater than the peak switching current in the application.

A lower inductor value increases the switching frequency, hence increases the losses which yields a lower overall efficiency.

As stated before, the NCP1406 is designed to operate in DCM. Stable operation in CCM is not guaranteed.

For all the mathematical equations given below, V_{IN} is the input voltage, T_{ON_MAX} is the maximum on-time which is typically 0.9 μ s, I_{LIM} is the current limit which is typically 0.8 A, L is the selected inductance, V_{OUT} is the desired output voltage, V_D is the Schottky diode forward voltage, and η is the conversion efficiency which can be assumed typically 80% for better margin for estimation.

Mode determination

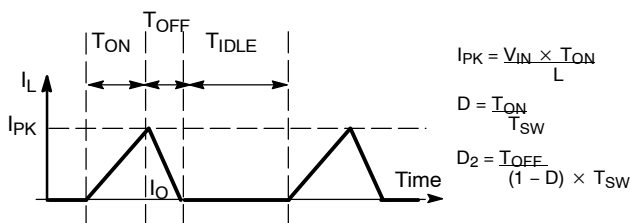

The on-time (inductor ramp up) can be expressed as following:

$$T_{ON} = \frac{L}{V_{IN}} \times I_{PK} \quad (\text{eq. 2})$$

The output current and the switching frequency can be expressed as following:

$$I_{OUT} = \frac{V_{IN} \times T_{ON}}{2 \times L} \times \frac{1}{\left(\frac{1}{D_2} - 1\right) + \frac{V_{OUT} + V_D}{\eta \times V_{IN}}} \quad (\text{eq. 3})$$

$$F_{SW} = \frac{\left(1 - \eta \frac{V_{IN}}{V_{OUT} + V_D}\right)}{T_{ON} \times \left(1 + \eta \frac{V_{IN}}{V_{OUT} + V_D} \left(\frac{1}{D_2} - 1\right)\right)}$$

In the above equations, D_2 gives us the information about the mode of operation (DCM or CCM). The value of D_2 will increase as load increases until it reaches 1, which corresponds to the state of critical conduction when the inductor current starts ramping up immediately after it reaches zero (starting a new cycle).

The value of the output current and the switching frequency at the critical mode transition ($D_2 = 1$) can be expressed as following:

$$I_{OUT} = \frac{V_{IN}^2 \times T_{ON}}{2 \times L \times (V_{OUT} + V_D)} \times \eta \quad (\text{eq. 4})$$

$$F_{SW}(load) = \frac{2 \times L \times I_{OUT}}{V_{IN} \times T_{ON}^2} \times \left(\frac{V_{OUT} + V_D}{\eta \times V_{IN}} - 1\right)$$

One can determine the mode of operation using the factor I_{ROOM} defined as:

$$I_{ROOM} = \frac{V_{IN}^2 \times T_{ON}}{2 \times L \times (V_{OUT} + V_D)} \times \eta - I_{OUT} \quad (\text{eq. 5})$$

If $I_{ROOM} < 0$,
the converter operates in continuous conduction mode.

If $I_{ROOM} = 0$,
the converter operates in critical conduction mode.

If $I_{ROOM} > 0$,
the converter operates in discontinuous conduction mode.

The Discontinuous Conduction Mode

For each switching cycle, if the internal MOSFET is switched on, it will be switched off only when either the maximum on-time, T_{ON} , of typical 0.9 μ s is reached or the inductor current limit of 0.8 A is met, whichever is earlier. Therefore, the designer can choose to use either the maximum on-time or the current limit to turn off the internal switch.

Minimizing the output ripple voltage

If the aim is to minimize output ripple voltage, the maximum on-time of 0.9 μ s should be used to turn off the MOSFET; however, the maximum output current will be reduced. It is critical to ensure that the maximum on-time has been reached before the current limit is met.

$$T_{ON_MAX} < \frac{L}{V_{IN}} \times I_{LIM} \quad (\text{eq. 6})$$

To ensure this condition is met, the inductance L should be selected according to the following equation:

$$L > \frac{V_{IN}}{I_{LIM}} \times T_{ON_MAX} \quad (\text{eq. 7})$$

The switching frequency at nominal load is expressed as:

$$f_{SW}(\text{load}) = \frac{2 \times L \times I_{OUT}}{V_{IN} \times T_{ON_MAX}^2} \times \left(\frac{V_{OUT} + V_D}{\eta \times V_{IN}} - 1 \right) \quad (\text{eq. 8})$$

The maximum output current under this maximum on-time control will be achieved at the limits of critical conduction mode and can be calculated from the equation below:

$$I_{OUT_MAX} = \frac{V_{IN}^2 \times T_{ON_MAX}}{2 \times L \times (V_{OUT} + V_D)} \times \eta \quad (\text{eq. 9})$$

The above equation for calculating I_{OUT_MAX} is for DCM mode operation only. The operation can go beyond the critical conduction mode if the current loading further increases above the maximum output current in DCM mode. However, stable operation in continuous conduction mode is hard to achieve. Refer below to the Continuous Conduction Mode section.

Maximizing the output current

If we target to maximize the output current, the current limit should be chosen to turn off the MOSFET, but this method will result in a larger output ripple voltage. It is critical to make sure that the current limit has been reached before the maximum on-time is met. To ensure this condition is met, the inductance L should be selected according to the following equation:

$$L < \frac{V_{IN}}{I_{LIM}} \times T_{ON_MAX} \quad (\text{eq. 10})$$

Since there are 100 ns internal propagation delay between the time the current limit is reached and the time the MOSFET is switched off, the actual peak inductor current can be obtained from the equation below:

$$I_{PK} = I_{LIM} + \frac{V_{IN}}{L} \times 100 \text{ ns} \quad (\text{eq. 11})$$

The switching frequency at nominal load is expressed as:

$$f_{SW}(\text{load}) = \frac{2 \times I_{OUT}(V_{OUT} + V_D - \eta \times V_{IN})}{I_{PK}^2 \times L} \quad (\text{eq. 12})$$

Then the maximum output current under the current limit control will be achieved at the limits of critical conduction mode and can be calculated by the equation below:

$$I_{OUT_MAX} = \frac{V_{IN} \times I_{PK}}{2 \times (V_{OUT} + V_D)} \times \eta \quad (\text{eq. 13})$$

This method can achieve larger maximum output current in DCM mode. Since the current limit is reached in each switching cycle, the inductor current ripple is larger resulting in larger output voltage ripple. Two ceramic capacitors in parallel can be used at the output to keep the output ripple small.

The Continuous Conduction Mode

The operation can go beyond the critical conduction mode if the current loading further increases above the maximum output current in DCM mode. However, stable operation in continuous conduction mode is hard to

achieve, and double pulsing or group pulsing will occur which will lead to much larger inductor current ripple and result in larger output ripple voltage.

Diode

The diode is the main source of loss in DC-DC converters. The key parameters which affect their efficiency are the forward voltage drop, V_D , and the reverse recovery time, t_{rr} . The forward voltage drop creates a loss just by having a voltage across the device with a current flowing through it. The reverse recovery time generates a loss when the diode is reverse biased, and the current appears to actually flow backwards through the diode due to the minority carriers being swept from the P-N junction. Care must be taken when choosing a diode. To achieve high efficiency, it is recommended to observe the following rules:

1. Small forward voltage, $V_D < 0.3 \text{ V}$.
2. Small reverse leakage current.
3. Fast reverse recovery time/switching speed.
4. Rated current larger than peak inductor current,

$I_{rated} > I_{PK}$.

5. Reverse voltage larger than output voltage, $V_{reverse} > V_{OUT}$.

Input Capacitor

The input capacitor stabilizes the input voltage and minimizes peak current ripple from the power source. The capacitor should be connected directly to the inductor pin where the input voltage is applied in order to effectively smooth the input current ripple and voltage due to the inductor current ripple. The input capacitor is also used to decouple the high frequency noise from the V_{DD} supply to the internal control circuit; therefore, the capacitor should be placed close to the V_{DD} pin. For some particular applications, separate decoupling capacitors should be provided and connected directly to the V_{DD} pin for better decoupling effect. A larger input capacitor can better reduce ripple current at the input. By reducing the ripple current at the input, the converter efficiency can be improved. In general, a 4.7 μF to 22 μF ceramic input capacitor is sufficient for most applications. X5R and X7R type ceramic capacitors are recommended due to their good capacitance tolerance and stable temperature behavior.

Output Capacitor

The output capacitor sustains the output voltage by providing the current required by the load and smooths the output ripple voltage. The choice of the output capacitor depends on the application's requirements for output voltage ripple. Low ESR output capacitors yield better output voltage filtering. Ceramic capacitors are recommended due to their low ESR at high switching frequency and low profile geometry. In general, a 3.3 μF to 22 μF ceramic capacitor should be appropriate for most applications. X5R and X7R type ceramic capacitors are

recommended due to their good capacitance tolerance and temperature coefficient, while Y5V type ceramic capacitors are not recommended since both their capacitance tolerance and temperature coefficient are too large. The output voltage ripple at nominal load current can be calculated by the following equations:

$$V_{\text{RIPPLE}} = I_{\text{PK}} \times \text{ESR} \quad (\text{eq. 14})$$

Where I_{OUT} is the nominal load current, C_{OUT} is the selected output capacitance, I_{PK} is the peak inductor current, L is the selected inductance, V_{OUT} is the output voltage, V_{D} is the Schottky diode forward voltage, V_{IN} is the input voltage, and ESR is the ESR of the output capacitor.

Feedback Resistors

To achieve better efficiency at light load, a high impedance feedback resistor divider should be used. Choose the lower resistor R2 value from the range of 10 kΩ to 200 kΩ. The value of the upper resistor R1 can then be calculated from the equation below:

$$R_1 = R_2 \times \left(\frac{V_{\text{OUT}}}{1.19} - 1 \right) \quad (\text{eq. 15})$$

1%-tolerance resistors should be used for both R1 and R2 for better V_{OUT} accuracy.

Feedforward Capacitor

A feedforward capacitor is required to add across the upper feedback resistor to avoid double pulsing or group pulsing at the switching node which will cause larger inductor ripple current and higher output voltage ripple. With adequate feedforward capacitance, evenly distributed single pulses at the switching node can be achieved. The range of the capacitor value is from 5 pF to 200 pF for most applications. For NCP1406, the lower the switching frequency, the larger the feedforward capacitance is needed. For the initial trial value of the feedforward capacitor, the following equation can be used; however, the actual value needs fine tuning:

$$C_{\text{FF}} \approx \frac{1}{2 \times \pi \times \frac{f_{\text{SW}}(\text{load})}{20} \times R_1} \quad (\text{eq. 16})$$

PCB Layout Guidelines

PCB layout is very important for switching converter performance. All the converter’s external components should be placed closed to the IC. The schematic, PCB trace layout, and component placement of the step-up DC-DC converter demonstration board are shown in Figures 32 through 35 for PCB layout design reference.

The following guidelines should be observed:

1. Grounding

Single-point grounding should be used for the output power return ground, the input power return ground, and the device switch ground to reduce noise. The input ground and output ground traces must be thick and short enough for current to flow through. A ground plane should be used to reduce ground bounce.

2. Power Traces

Low resistance conducting paths (short and thick traces) should be used for the power carrying traces to reduce power loss so as to improve efficiency (short and thick traces for connecting the inductor L can also reduce stray inductance). The path between C1, L1, D1, and C2 should be kept short. The trace from L to LX pin of the IC should also be kept short.

3. External Feedback Components

Feedback resistors R1 and R2, and feedforward capacitor C3 should be located as close to the FB pin as possible to minimize noise picked up by the FB pin. The ground connection of the feedback resistor divider should be connected directly to the GND pin.

4. Input Capacitor

The input capacitor should be located close to both the input to the inductor and the VDD pin of the IC.

5. Output Capacitor

The output capacitor should be placed close to the output terminals to obtain better smoothing effect on output ripple voltage.

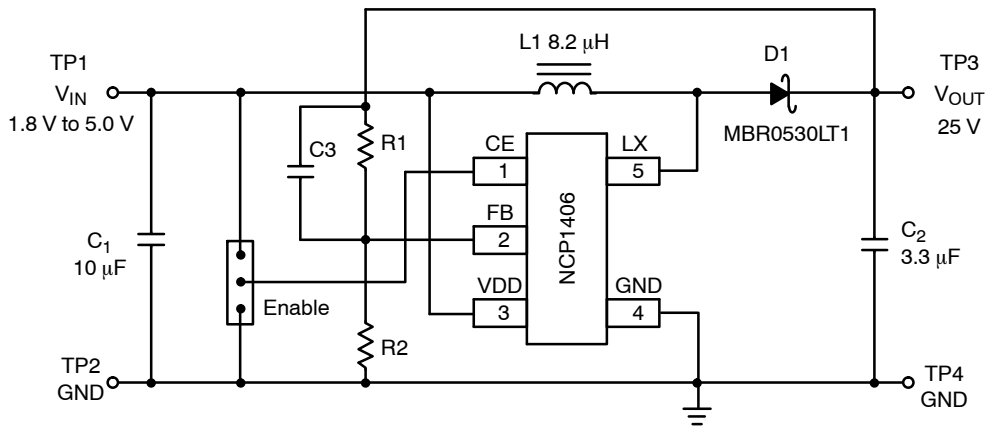

Figure 32. Step-Up Converter Demonstration Board Schematic

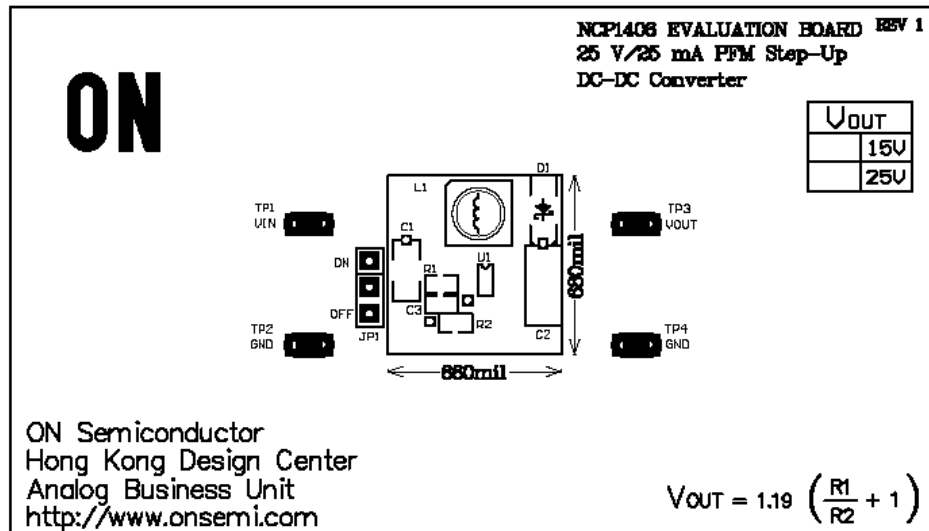

Figure 33. Step-Up Converter Demonstration Board
Top Layer Component Silkscreen

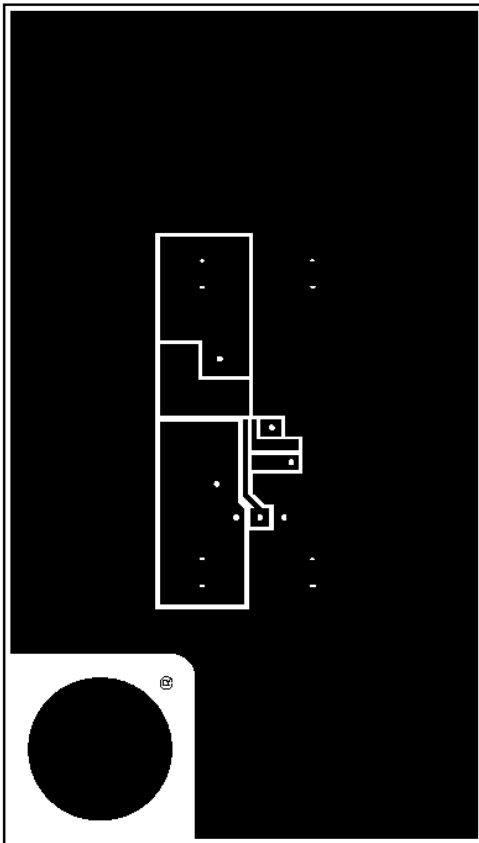

Figure 34. Step-Up Converter Demonstration Board
Top Layer Copper

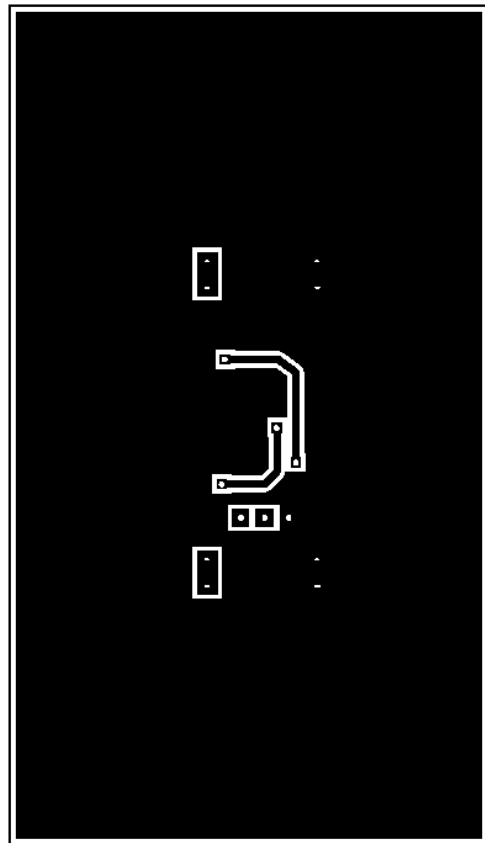

Figure 35. Step-Up Converter Demonstration Board
Bottom Layer Copper

NCP1406, NCV1406

Components and Suppliers

Output Voltage	Parts	Supplier	Part Number	Description	Website
15 V	C1	Panasonic	ECJ2FB0J106M	Ceramic Capacitor 0805, 10 μ F/6.3 V	www.panasonic.com
		TDK	C1608X5R0J475MT	Ceramic Capacitor 0603, 10 μ F/6.3 V	www.component.tdk.com
	C2	Panasonic	ECJ3YB1E475M	Ceramic Capacitor 1206, 4.7 μ F/25 V	www.panasonic.com
		TDK	C3216X5R1E475MT	Ceramic Capacitor 1206, 4.7 μ F/25 V	www.component.tdk.com
	C3	Panasonic	ECJ1VC1H560K	Ceramic Capacitor 0603, 56 pF/50 V	www.panasonic.com
		TDK	C1005C0G1H560JT	Ceramic Capacitor 0402, 56 pF/50 V	www.component.tdk.com
	D1	ON Semiconductor	MBR0520LT1	Schottky Power Rectifier 20 V/500 mA	www.onsemi.com
	L1	Sumida Electric Co.	CMD4D11-100MC	Inductor 10 μ H 1.2 mm Low Profile	www.sumida.com
		TDK	VLF4012AT-100MR79	Inductor 10 μ H 1.2 mm Low Profile	www.component.tdk.com
	R1	Panasonic	ERJ3GEYJ135V	Resistor 0603, 1.3 M Ω	www.panasonic.com
	R2	Panasonic	ERJ3GEYJ114V	Resistor 0603, 110 k Ω	www.panasonic.com
U1	ON Semiconductor	NCP1406SNT1	25 V Step-up DC-DC Converter	www.onsemi.com	
25 V	C1	Panasonic	ECJ2FB0J106M	Ceramic Capacitor 0805, 10 μ F/6.3 V	www.panasonic.com
		TDK	C1608X5R0J475MT	Ceramic Capacitor 0603, 10 μ F/6.3 V	www.component.tdk.com
	C2	Panasonic	ECJ5YB1H335M	Ceramic Capacitor 1812, 3.3 μ F/50 V	www.panasonic.com
		TDK	C3225X5R1H475MT	Ceramic Capacitor 1206, 3.3 μ F/50 V	www.component.tdk.com
	C3	Panasonic	ECJ1VC1H151K	Ceramic Capacitor 0603, 150 pF/50 V	www.panasonic.com
		TDK	C1005C0G1H151JT	Ceramic Capacitor 0402, 150 pF/50 V	www.component.tdk.com
	D1	ON Semiconductor	MBR0530LT1	Schottky Power Rectifier 30 V/500 mA	www.onsemi.com
	L1	Sumida Electric Co.	CMD4D11-100MC	Inductor 10 μ H 1.2 mm Low Profile	www.sumida.com
		TDK	VLF4012AT-100MR79	Inductor 10 μ H 1.2 mm Low Profile	www.component.tdk.com
	R1	Panasonic	ERJ3GEYJ225V	Resistor 0603, 2.2 M Ω	www.panasonic.com
	R2	Panasonic	ERJ3GEYJ114V	Resistor 0603, 110 k Ω	www.panasonic.com
U1	ON Semiconductor	NCP1406SNT1G	25 V Step-up DC-DC Converter	www.onsemi.com	

NCP1406, NCV1406

OTHER APPLICATION CIRCUITS

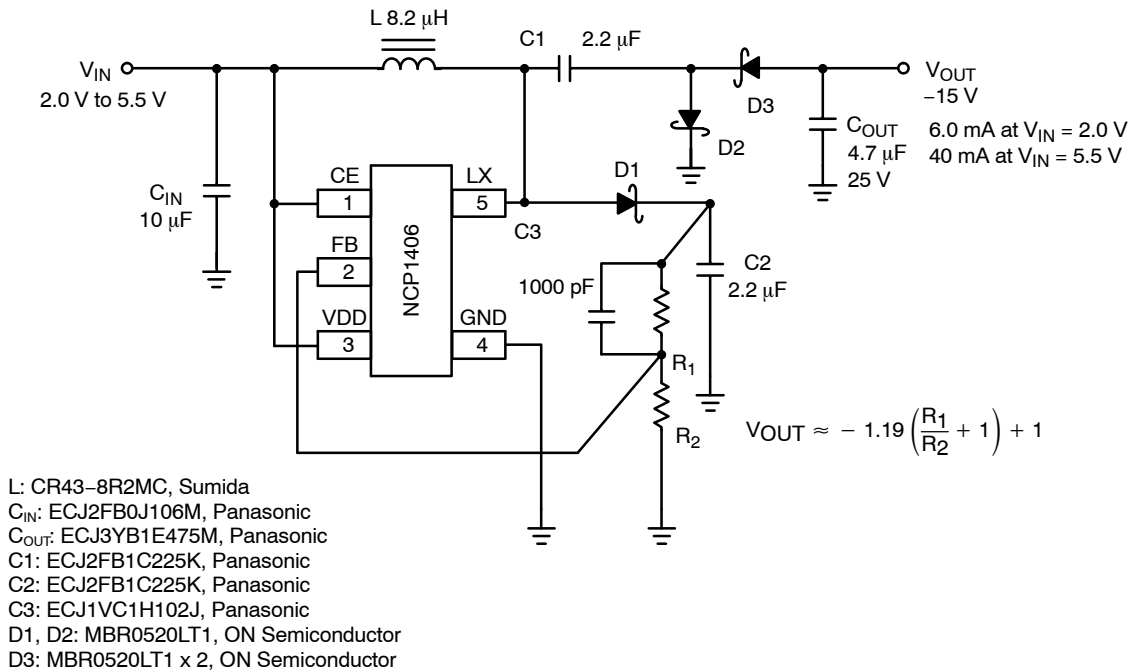

Figure 36. Positive-to-Negative Output Converter for Negative LCD Bias

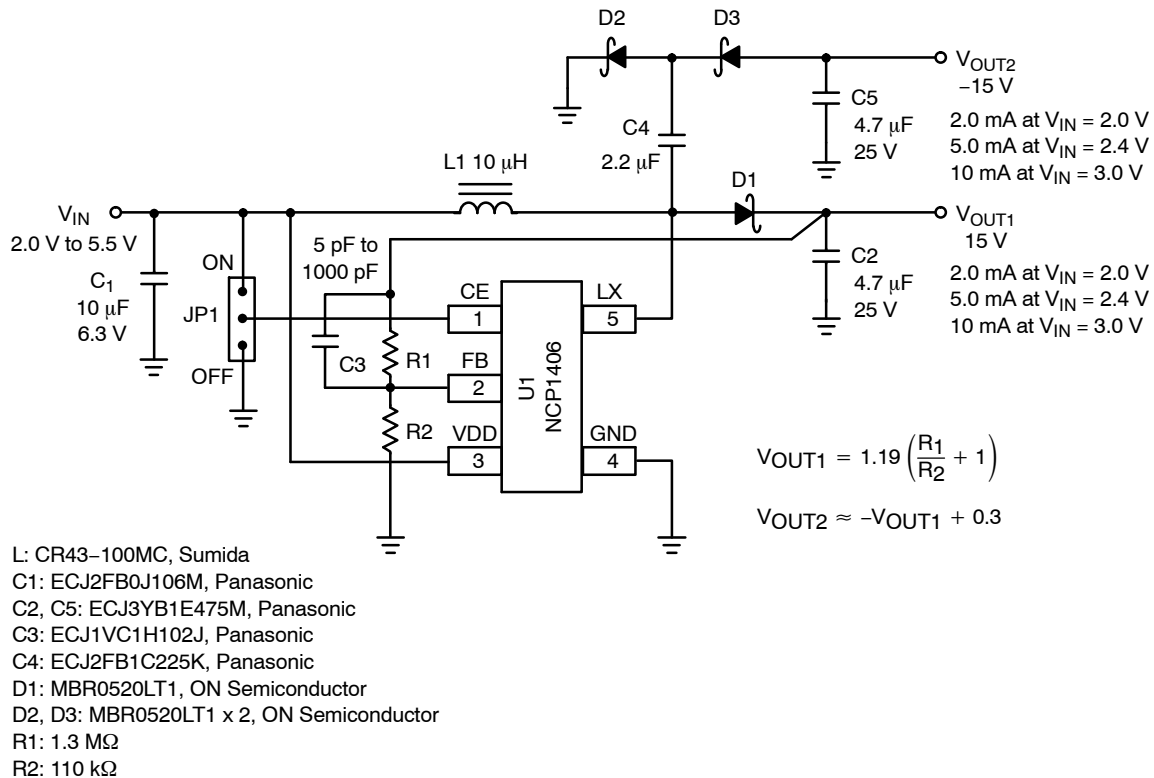
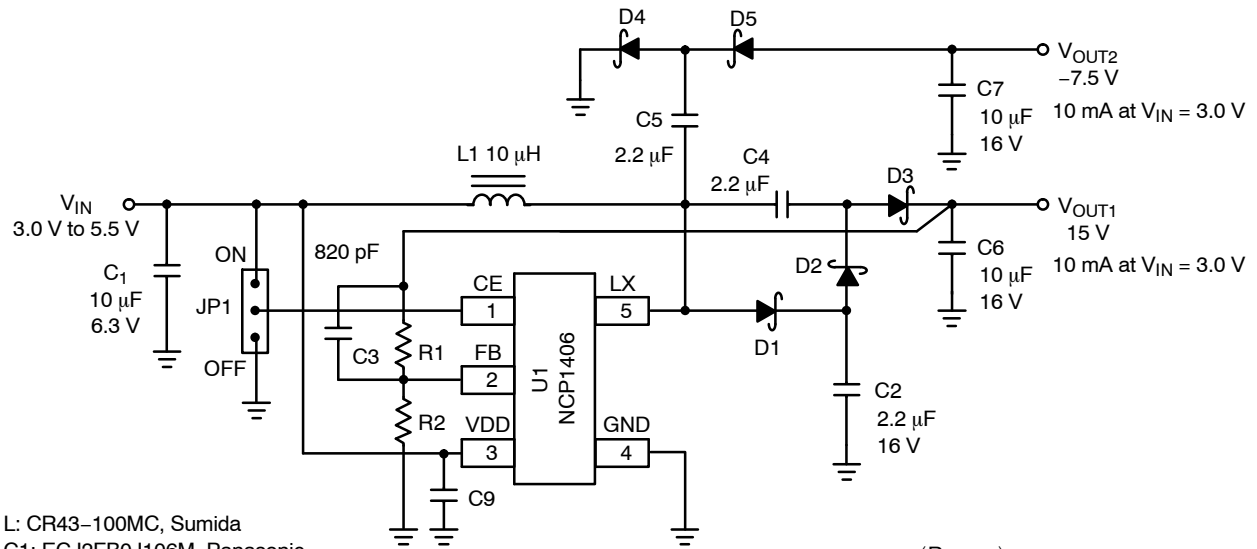

Figure 37. +15 V, -15 V Outputs Converter for LCD Bias Supply

NCP1406, NCV1406



- L: CR43-100MC, Sumida
 C1: ECJ2FB0J106M, Panasonic
 C6, C7: ECJ3YB1C106M, Panasonic
 C3: ECJ1VC1H821J, Panasonic
 C2, C4, C5: ECJ2FB1C225K, Panasonic
 D1, D2, D3, D4, D5: MBR0520LT1, ON Semiconductor
 R1: 1.3 M Ω
 R2: 110 k Ω

$$V_{OUT1} = 1.19 \left(\frac{R_1}{R_2} + 1 \right)$$

$$V_{OUT2} \approx -\frac{V_{OUT1}}{2}$$

Figure 38. +15 V, -7.5 V Outputs Converter for CCD Supply Circuit

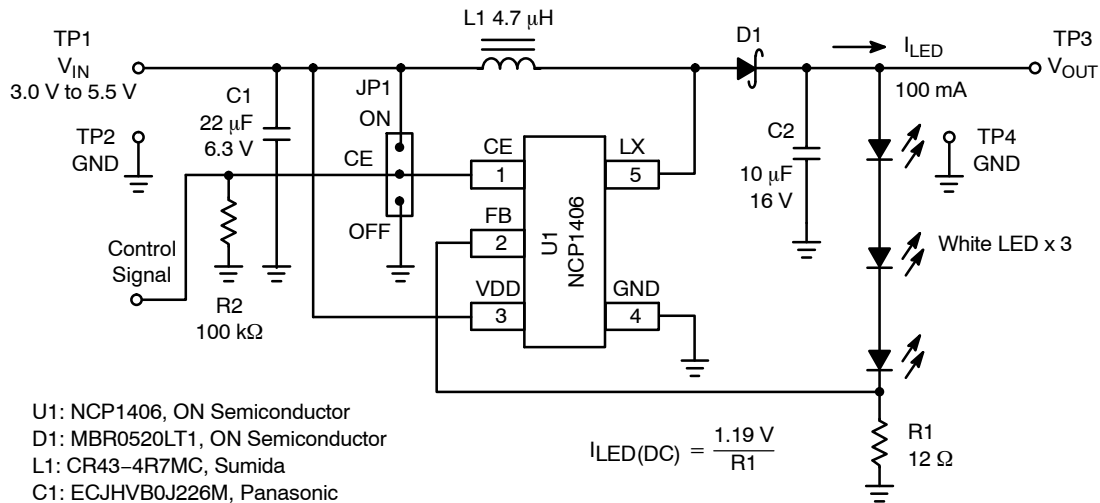

- U1: NCP1406, ON Semiconductor
 D1: MBR0520LT1, ON Semiconductor
 L1: CR43-4R7MC, Sumida
 C1: ECJHVB0J226M, Panasonic
 C2: ECJ3YB1C106M, Panasonic
 LED1, LED2, LED3: LWH1033 (Luxpia)
 R1: 12 Ω
 R2: 100 k Ω

$$I_{LED(DC)} = \frac{1.19 V}{R_1}$$

Figure 39. White LEDs Driver Circuit

NCP1406, NCV1406

PACKAGE DIMENSIONS

TSOP-5
SN SUFFIX
CASE 483-02
ISSUE H

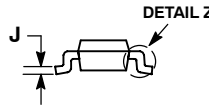
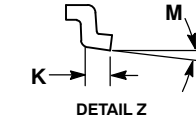
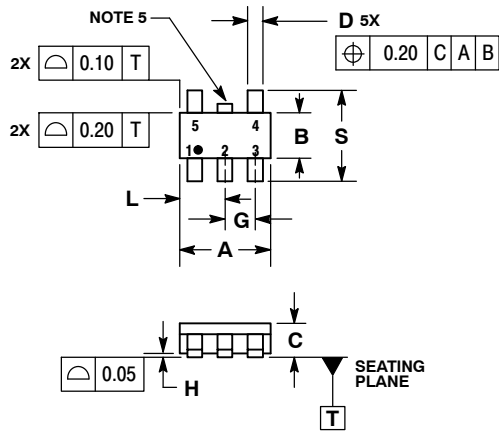

NOTES:

1. DIMENSIONING AND TOLERANCING PER ASME Y14.5M, 1994.
2. CONTROLLING DIMENSION: MILLIMETERS.
3. MAXIMUM LEAD THICKNESS INCLUDES LEAD FINISH THICKNESS. MINIMUM LEAD THICKNESS IS THE MINIMUM THICKNESS OF BASE MATERIAL.
4. DIMENSIONS A AND B DO NOT INCLUDE MOLD FLASH, PROTRUSIONS, OR GATE BURRS.
5. OPTIONAL CONSTRUCTION: AN ADDITIONAL TRIMMED LEAD IS ALLOWED IN THIS LOCATION. TRIMMED LEAD NOT TO EXTEND MORE THAN 0.2 FROM BODY.

DIM	MILLIMETERS	
	MIN	MAX
A	3.00	BSC
B	1.50	BSC
C	0.90	1.10
D	0.25	0.50
G	0.95	BSC
H	0.01	0.10
J	0.10	0.26
K	0.20	0.60
L	1.25	1.55
M	0°	10°
S	2.50	3.00

SOLDERING FOOTPRINT*

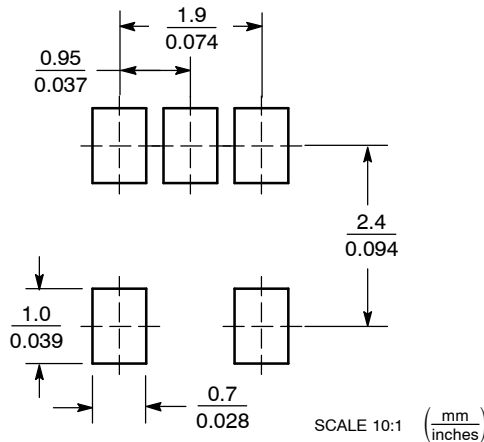

*For additional information on our Pb-Free strategy and soldering details, please download the ON Semiconductor Soldering and Mounting Techniques Reference Manual, SOLDERRM/D.

ON Semiconductor and are registered trademarks of Semiconductor Components Industries, LLC (SCILLC). SCILLC owns the rights to a number of patents, trademarks, copyrights, trade secrets, and other intellectual property. A listing of SCILLC's product/patent coverage may be accessed at www.onsemi.com/site/pdf/Patent-Marking.pdf. SCILLC reserves the right to make changes without further notice to any products herein. SCILLC makes no warranty, representation or guarantee regarding the suitability of its products for any particular purpose, nor does SCILLC assume any liability arising out of the application or use of any product or circuit, and specifically disclaims any and all liability, including without limitation special, consequential or incidental damages. "Typical" parameters which may be provided in SCILLC data sheets and/or specifications can and do vary in different applications and actual performance may vary over time. All operating parameters, including "Typicals" must be validated for each customer application by customer's technical experts. SCILLC does not convey any license under its patent rights nor the rights of others. SCILLC products are not designed, intended, or authorized for use as components in systems intended for surgical implant into the body, or other applications intended to support or sustain life, or for any other application in which the failure of the SCILLC product could create a situation where personal injury or death may occur. Should Buyer purchase or use SCILLC products for any such unintended or unauthorized application, Buyer shall indemnify and hold SCILLC and its officers, employees, subsidiaries, affiliates, and distributors harmless against all claims, costs, damages, and expenses, and reasonable attorney fees arising out of, directly or indirectly, any claim of personal injury or death associated with such unintended or unauthorized use, even if such claim alleges that SCILLC was negligent regarding the design or manufacture of the part. SCILLC is an Equal Opportunity/Affirmative Action Employer. This literature is subject to all applicable copyright laws and is not for resale in any manner.

PUBLICATION ORDERING INFORMATION

LITERATURE FULFILLMENT:
Literature Distribution Center for ON Semiconductor
P.O. Box 5163, Denver, Colorado 80217 USA
Phone: 303-675-2175 or 800-344-3860 Toll Free USA/Canada
Fax: 303-675-2176 or 800-344-3867 Toll Free USA/Canada
Email: orderlit@onsemi.com

N. American Technical Support: 800-282-9855 Toll Free
USA/Canada
Europe, Middle East and Africa Technical Support:
Phone: 421 33 790 2910
Japan Customer Focus Center
Phone: 81-3-5817-1050

ON Semiconductor Website: www.onsemi.com
Order Literature: <http://www.onsemi.com/orderlit>

For additional information, please contact your local Sales Representative