



Chipsmall Limited consists of a professional team with an average of over 10 year of expertise in the distribution of electronic components. Based in Hongkong, we have already established firm and mutual-benefit business relationships with customers from,Europe,America and south Asia,supplying obsolete and hard-to-find components to meet their specific needs.

With the principle of “Quality Parts,Customers Priority,Honest Operation,and Considerate Service”,our business mainly focus on the distribution of electronic components. Line cards we deal with include Microchip,ALPS,ROHM,Xilinx,Pulse,ON,Everlight and Freescale. Main products comprise IC,Modules,Potentiometer,IC Socket,Relay,Connector.Our parts cover such applications as commercial,industrial, and automotives areas.

We are looking forward to setting up business relationship with you and hope to provide you with the best service and solution. Let us make a better world for our industry!



Contact us

Tel: +86-755-8981 8866 Fax: +86-755-8427 6832

Email & Skype: info@chipsmall.com Web: www.chipsmall.com

Address: A1208, Overseas Decoration Building, #122 Zhenhua RD., Futian, Shenzhen, China





Test Procedure for the NCP59301DS00GEVB Evaluation Board

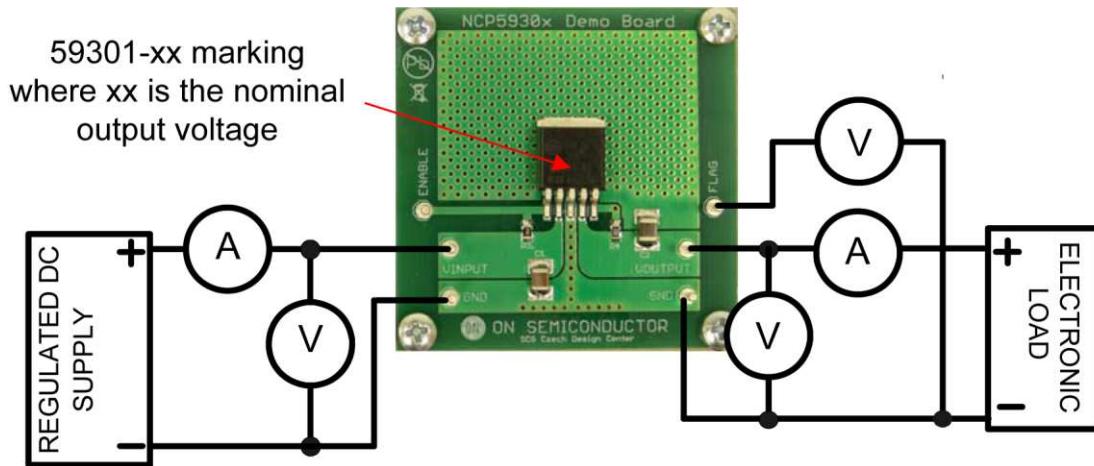

Figure 1: Test Setup

Test Procedure

1. Connect the test setup as shown in Figure 1.
2. Apply an input voltage, $V_{in} = V_{out_nom} + 1\text{ V}$
3. Apply $I_{out} = 10\text{ mA}$ load.
4. Check that V_{out} is V_{out_nom}
5. Increase I_{out} load to 3 A
6. Check that V_{out} is V_{out_nom}
7. Check by Multimeter referenced to GND that V_{flag} is roughly V_{out_nom}
8. Decrease input voltage until $V_{out} = 90\%$ of V_{out_nom}
9. Check that V_{flag} is less than 0.4 V
10. Power down the load
11. Power down V_{input}
12. End of test