



Chipsmall Limited consists of a professional team with an average of over 10 year of expertise in the distribution of electronic components. Based in Hongkong, we have already established firm and mutual-benefit business relationships with customers from,Europe,America and south Asia,supplying obsolete and hard-to-find components to meet their specific needs.

With the principle of “Quality Parts,Customers Priority,Honest Operation,and Considerate Service”,our business mainly focus on the distribution of electronic components. Line cards we deal with include Microchip,ALPS,ROHM,Xilinx,Pulse,ON,Everlight and Freescale. Main products comprise IC,Modules,Potentiometer,IC Socket,Relay,Connector.Our parts cover such applications as commercial,industrial, and automotives areas.

We are looking forward to setting up business relationship with you and hope to provide you with the best service and solution. Let us make a better world for our industry!



## Contact us

Tel: +86-755-8981 8866 Fax: +86-755-8427 6832

Email & Skype: info@chipsmall.com Web: www.chipsmall.com

Address: A1208, Overseas Decoration Building, #122 Zhenhua RD., Futian, Shenzhen, China



## Test Procedure for the NCP702SN33T1GEVB Evaluation Board

04-JUN-12

### Test Setup 1:

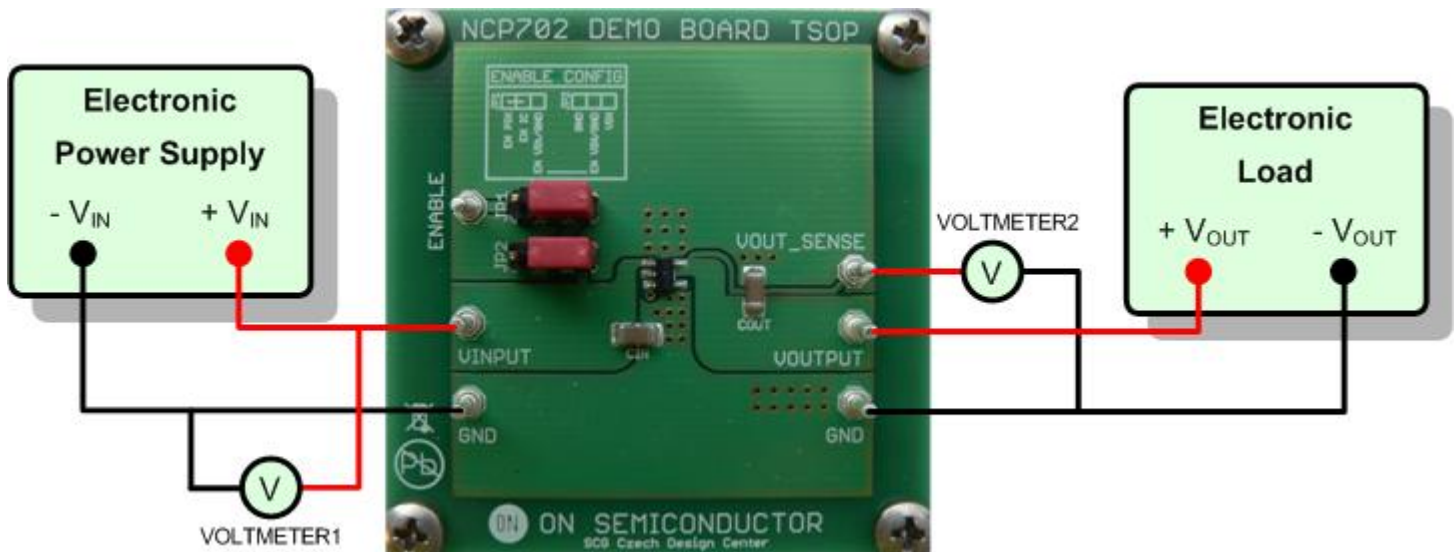

Figure 1. Test setup for the measurements of basic regulation characteristics

### Required Equipment:

2 x Voltmeters

DC Power Supply – Max. 5.5V

Electronic Load



### Test Procedure for the Measurement of Line Regulation parameter using Test Setup 1:

1. Connect the test setup as shown on Figure 1,
2. Set the electronic load for the required load current e.g.  $I_{OUT} = 10\text{mA}$ ,
3. Apply the required minimum input voltage e.g.  $V_{IN\_MIN} = V_{OUT\_NOM} + 0.3\text{V}^{(1)}$ ,
4. Note the output voltage reading  $V_{OUT1}$  indicated by VOTLMETER2,
5. Apply the required maximum input voltage e.g.  $V_{IN\_MAX} = V_{OUT\_NOM} + 1.3\text{V}^{(1)}$ ,
6. Note the output voltage reading  $V_{OUT2}$  indicated by VOTLMETER2,
7. Calculate the Line Regulation parameter as:  
$$\text{Reg}_{LINE} = (V_{OUT2} - V_{OUT1}) / (V_{IN\_MAX} - V_{IN\_MIN}) \text{ [V/V]}$$
8. Turn off the electronic load. Turn off the input power supply,
9. End of the test.

### Test Procedure for the Measurement of Load Regulation parameter using Test Setup 1:

1. Connect the test setup as shown on Figure 1,
2. Set the electronic load for the required minimum output current e.g.  $I_{OUT\_MIN} = 1\text{mA}$ ,
3. Apply the desired input voltage e.g.  $V_{IN} = V_{OUT\_NOM} + 0.3\text{V}^{(1)}$ ,
4. Note the output voltage reading  $V_{OUT1}$  indicated by VOTLMETER2,
5. Set the electronic load for the required maximum output current e.g.  $I_{OUT\_MAX} = 150\text{mA}$ ,
6. Note the output voltage reading  $V_{OUT2}$  indicated by VOTLMETER2,
7. Calculate the Load Regulation parameter as:  
$$\text{Reg}_{LOAD} = (V_{OUT2} - V_{OUT1}) / (I_{OUT\_MAX} - I_{OUT\_MIN}) \text{ [V/A]}$$
5. Turn off the electronic load. Turn off the input power supply,
6. End of the test.

<sup>(1)</sup>  $V_{OUT\_NOM}$  is the nominal output voltage level of the regulator. NCP702 operating  $V_{IN}$  must be in the range  $2.0\text{V} \leq V_{IN} \leq 5.5\text{V}$

## Test Setup 2:

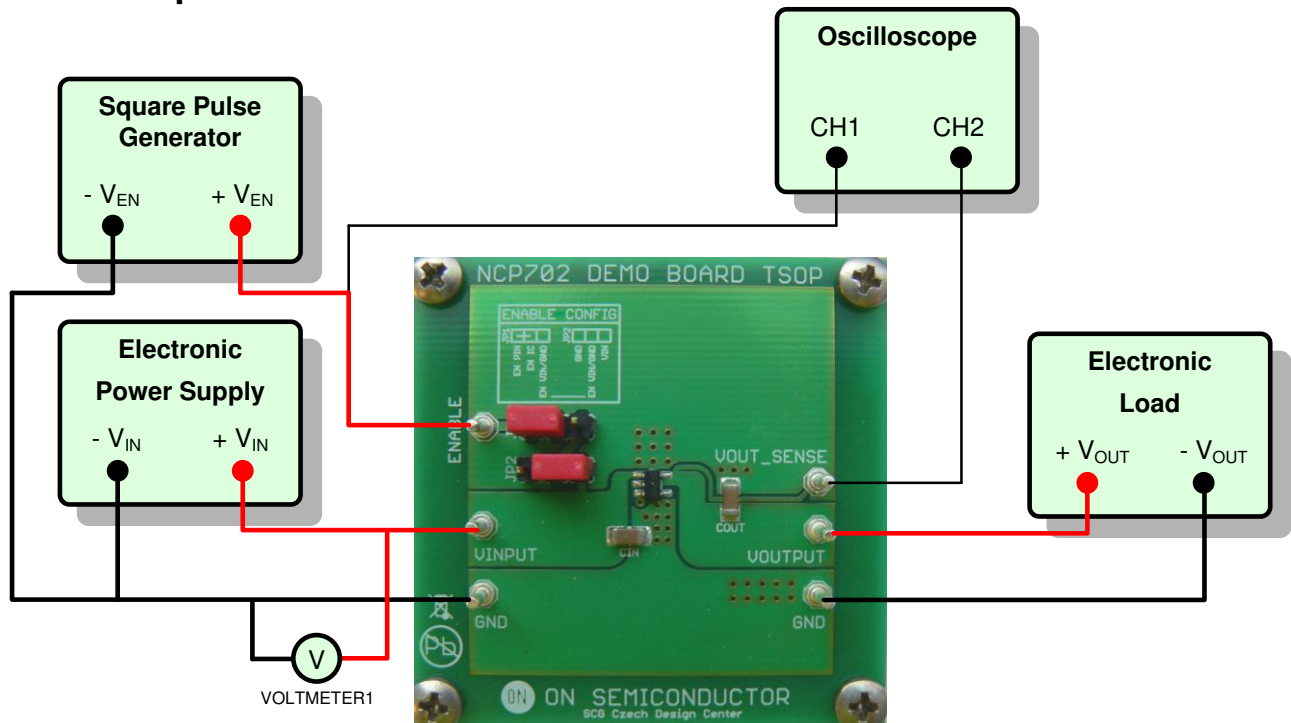

Figure 2. Test setup for the measurements of the Enable functionality

### Required Equipment:

DC Power Supply – Max. 5.5V  
 Electronic Load, Voltmeter, Oscilloscope



## Test Procedure for the measurements of the Enable functionality using Test Setup 2:

1. Connect the test setup as shown on Figure 2,
2. Apply the required input voltage e.g.  $V_{IN} = V_{OUT\_NOM} + 0.3V$  <sup>(1)</sup>
3. Set the electronic load for the required load current e.g.  $I_{OUT} = 10mA$ ,
4. Set the square wave generator to generate the following pulse waveform:

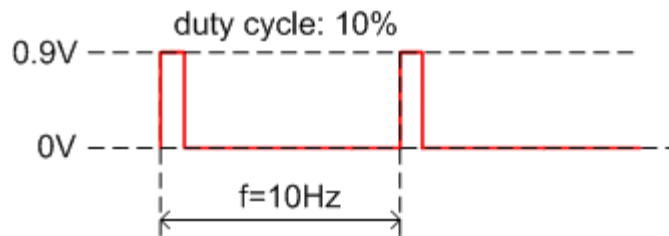

5. Verify with the oscilloscope that the output voltage  $V_{OUT}$  turns ON/OFF.
6. Turn off the pulse generator.
7. Turn off the electronic load.
8. Turn off the input power supply
9. End of the test

<sup>(1)</sup>  $V_{OUT\_NOM}$  is the nominal output voltage level of the regulator. NCP702 operating  $V_{IN}$  must be in the range  $2.0V \leq V_{IN} \leq 5.5V$



**Test Setup 3:**

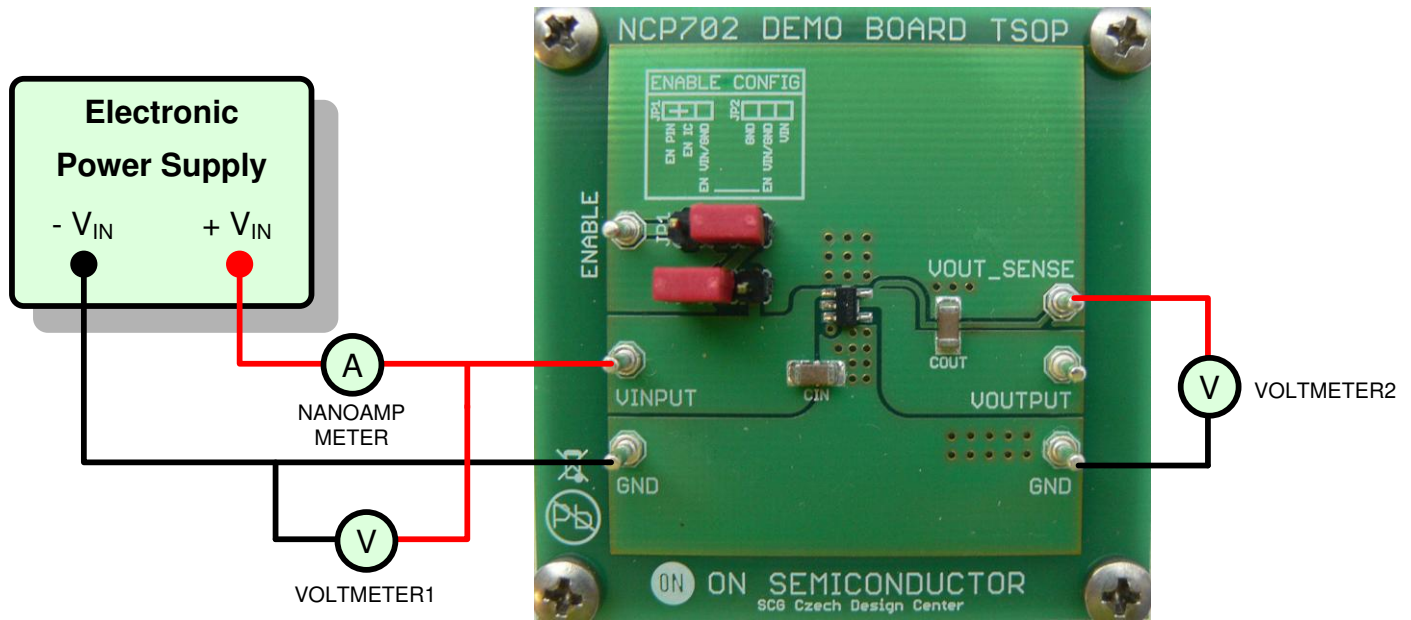

Figure 3. Test setup for the measurements of the disable current

**Required Equipment:**

- DC Power Supply – Max. 5.5V
- 2 x Voltmeter, Nanoampere meter



### Test Procedure for the measurements of the disable current using Test Setup 3:

1. Connect the test setup as shown on Figure 3,
2. Apply the required input voltage e.g. so that Voltmeter1 indicates  $V_{IN} = V_{OUT\_NOM} + 0.3V$  <sup>(1)</sup>
3. Verify that the output voltage measured by Voltmeter2 is very close to 0V,
4. Read the disable current measured by the nanoampere meter.
5. Turn off the input power supply
6. End of the test

<sup>(1)</sup>  $V_{OUT\_NOM}$  is the nominal output voltage level of the regulator. NCP702 operating  $V_{IN}$  must be in the range  $2.0V \leq V_{IN} \leq 5.5V$ .