



Chipsmall Limited consists of a professional team with an average of over 10 year of expertise in the distribution of electronic components. Based in Hongkong, we have already established firm and mutual-benefit business relationships with customers from,Europe,America and south Asia,supplying obsolete and hard-to-find components to meet their specific needs.

With the principle of “Quality Parts,Customers Priority,Honest Operation,and Considerate Service”,our business mainly focus on the distribution of electronic components. Line cards we deal with include Microchip,ALPS,ROHM,Xilinx,Pulse,ON,Everlight and Freescale. Main products comprise IC,Modules,Potentiometer,IC Socket,Relay,Connector.Our parts cover such applications as commercial,industrial, and automotives areas.

We are looking forward to setting up business relationship with you and hope to provide you with the best service and solution. Let us make a better world for our industry!



Contact us

Tel: +86-755-8981 8866 Fax: +86-755-8427 6832

Email & Skype: info@chipsmall.com Web: www.chipsmall.com

Address: A1208, Overseas Decoration Building, #122 Zhenhua RD., Futian, Shenzhen, China



NCT203

Low Voltage, High Accuracy Temperature Monitor with I²C Interface

The NCT203 is a digital thermometer and undertemperature/ overtemperature alarm, intended for use in thermal management systems requiring low power and size. The NCT203 operates over a supply range of 1.4 V to 2.75 V making it possible to use it in a wide range of applications including low power devices.

The NCT203 can measure the ambient temperature accurate to $\pm 1.75^{\circ}\text{C}$. The device operates over a wide temperature range of -40 to $+125^{\circ}\text{C}$.

The NCT203 has a configurable $\overline{\text{ALERT}}$ output and over-temperature shutdown $\overline{\text{THERM}}$ pin.

Communication with the NCT203 is accomplished via the I²C interface which is compatible with industry standard protocols. Through this interface the NCT203s internal registers may be accessed. These registers allow the user to read the current temperature, change the configuration settings and adjust limits.

An $\overline{\text{ALERT}}$ output signals when the on-chip temperature is out of range. The $\overline{\text{THERM}}$ output is a comparator output that can be used to shut down the system if it exceeds the programmed limit. The $\overline{\text{ALERT}}$ output can be reconfigured as a second $\overline{\text{THERM}}$ output, if required.

Features

- Small DFN Package
- On-Chip Temperature Sensor
- Low Voltage Operation: 1.4 V to 2.75 V
- Low Quiescent Current:
 - ◆ 44 μA Normal Mode (max)
 - ◆ 20 μA Shutdown (max)
- Power Saving Shutdown Mode
- Operating Temperature Range of -40°C to 125°C
- 2-wire I²C Serial Interface
- Programmable Over/Undertemperature Limits
- This is a Pb-Free Device

Applications

- Smart Phones, Tablet PCs, Satellite Navigation, Smart Batteries



ON Semiconductor®

<http://onsemi.com>



DFN8
MT SUFFIX
CASE 511BU

PIN ASSIGNMENTS

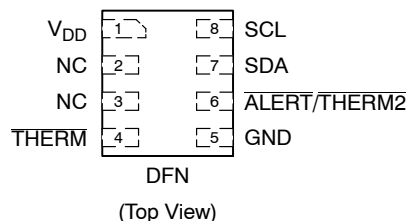

MARKING DIAGRAM

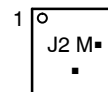

J2 = Specific Device Code
M = Date Code
■ = Pb-Free Device

(*Note: Microdot may be in either location)

ORDERING INFORMATION

See detailed ordering and shipping information in the package dimensions section on page 13 of this data sheet.

NCT203

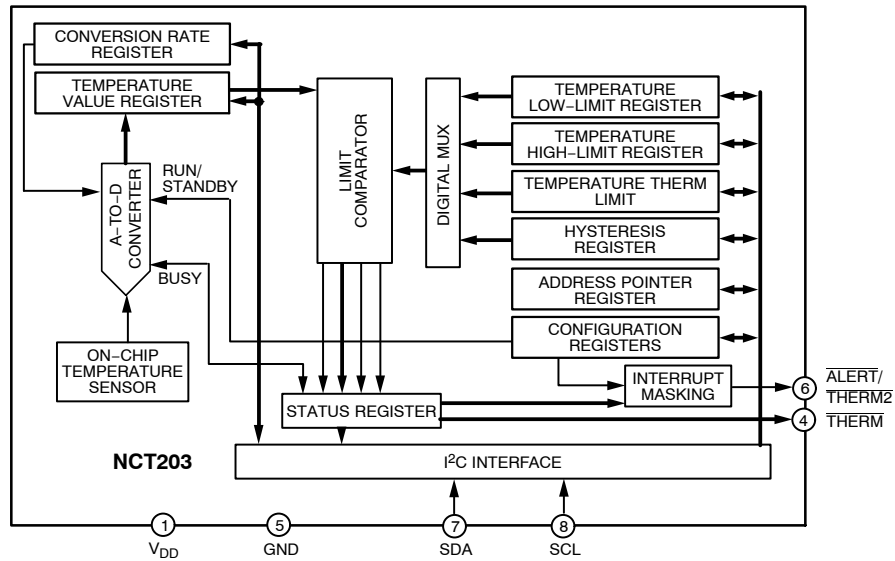

Figure 1. Functional Block Diagram

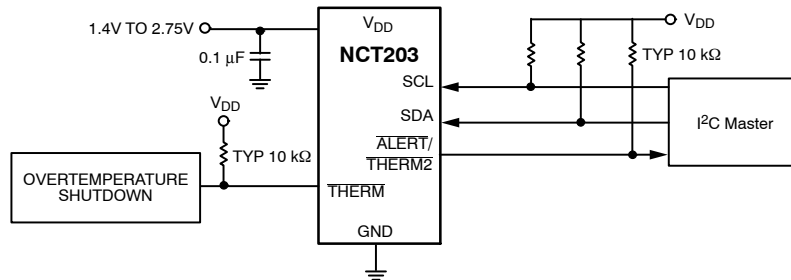

Figure 2. Typical Application Circuit

Table 1. PIN FUNCTION DESCRIPTION – DFN PACKAGE

Pin No.	Pin Name	Description
1	V _{DD}	Positive Supply, 1.4 V to 2.75 V
2	NC	No connect – leave this pin floating.
3	NC	No connect – leave this pin floating.
4	THERM	Open-Drain Output. Can be used to throttle a CPU clock in the event of an overtemperature condition. Requires pullup resistor to V _{DD} . Active low output.
5	GND	Supply Ground Connection.
6	ALERT/THERM2	Open-Drain Logic Output used as Interrupt. This can also be configured as a second THERM output. Requires pullup resistor to V _{DD} . Active low output.
7	SDA	Logic Input/Output, I ² C Serial Data. Requires pullup resistor to V _{DD} .
8	SCL	Logic Input, I ² C serial clock. Requires pullup resistor to V _{DD} .

NCT203

Table 2. ABSOLUTE MAXIMUM RATINGS (Note 1)

Rating	Symbol	Value	Unit
Supply Voltage (V_{DD}) to GND	V_{DD}	-0.3, +3	V
SCL, SDA, ALERT, THERM		-0.3 to +5.25	V
Input current on SDA, THERM	I_{IN}	-1, +50	mA
Maximum Junction Temperature	$T_{J(max)}$	150.7	°C
Operating Temperature Range	TOP	-40 to 125	°C
Storage Temperature Range	T_{STG}	-65 to 160	°C
ESD Capability, Human Body Model (Note 2)	ESD _{HBM}	2000	V
ESD Capability, Machine Model (Note 2)	ESD _{MM}	100	V

Stresses exceeding Maximum Ratings may damage the device. Maximum Ratings are stress ratings only. Functional operation above the Recommended Operating Conditions is not implied. Extended exposure to stresses above the Recommended Operating Conditions may affect device reliability.

- Refer to ELECTRICAL CHARACTERISTICS and APPLICATION INFORMATION for Safe Operating Area.
- This device series incorporates ESD protection and is tested by the following methods:
 ESD Human Body Model tested per AEC-Q100-002 (EIA/JESD22-A114)
 ESD Machine Model tested per AEC-Q100-003 (EIA/JESD22-A115)

Table 3. I²C TIMING – 400 kHz

Parameter (Note 3)	Symbol	Min	Typ	Max	Unit
Clock Frequency	f_{SCLK}	10		400	kHz
Clock Period	t_{SCLK}	2.5			μs
SCL High Time	t_{HIGH}	0.6			μs
SCL Low Time	t_{LOW}	1.3			μs
Start Setup Time	$t_{SU;STA}$	0.6			μs
Start Hold Time (Note 4)	$t_{HD;STA}$	0.6			μs
Data Setup Time (Note 5)	$t_{SU;DAT}$	100			ns
Data Hold Time (Note 6)	$t_{HD;DAT}$			0.9	μs
SCL, SDA Rise Time	t_r			300	ns
SCL, SDA Fall Time	t_f			300	ns
Stop Setup Time	$t_{SU;STO}$	0.6			μs
Bus Free Time	t_{BUF}	1.3			μs
Glitch Immunity	t_{SW}			50	ns

- Guaranteed by design, but not production tested.
- Time from 10% of SDA to 90% of SCL.
- Time for 10% or 90% of SDA to 10% of SCL.
- A device must internally provide a hold time of at least 300 ns for the SDA signal to bridge the undefined region of the falling edge of SCL.

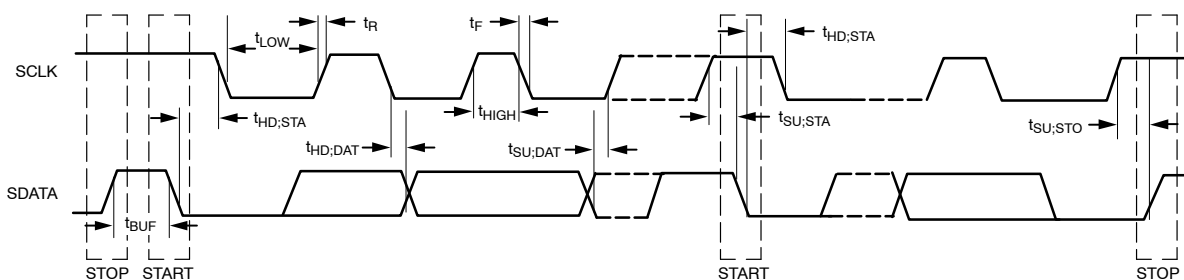

Figure 3. I²C Timing Diagram

NCT203

Table 4. ELECTRICAL CHARACTERISTICS

($T_A = T_{MIN}$ to T_{MAX} , $V_{DD} = 1.6$ V to 2.75 V. All specifications for -40°C to $+125^{\circ}\text{C}$, unless otherwise noted.)

Parameter	Test Conditions	Min	Typ	Max	Unit
TEMPERATURE SENSOR					
Measurement Range		-40		+125	$^{\circ}\text{C}$
TEMPERATURE SENSOR ACCURACY					
V_{DD}	$T_A = 25^{\circ}\text{C}$ to 85°C $T_A = -40^{\circ}\text{C}$ to $+125^{\circ}\text{C}$			± 1.75 ± 3	$^{\circ}\text{C}$
	$V_{DD} = 1.8$ V, $T_A = 40^{\circ}\text{C}$ to $+100^{\circ}\text{C}$	-0.5		1.5	$^{\circ}\text{C}$
ADC Resolution			10		Bits
Conversion time			60		ms
Temperature Resolution			1		$^{\circ}\text{C}$
Undervoltage Lockout Threshold			1.32		V
Power-On Reset Threshold			0.9		V
POWER REQUIREMENTS					
Supply Voltage		1.4		2.75	V
Quiescent Current (I_{DD})	$I^2\text{C}$ inactive – 0.0625 Conversions/Sec Rate, 1.8 V V_{DD} $I^2\text{C}$ active, 400 kHz		15 30	44	μA
Standby Current (I_{STBY})	$I^2\text{C}$ inactive $I^2\text{C}$ active, 400 kHz		1 10	20	μA
DIGITAL INPUT/OUTPUT					
Input Logic Levels	V_{IH}	$0.7 \times V_{DD}$		2.75	V
	V_{IL}	-0.5		$0.3 \times V_{DD}$	V
Input Current	$0 < V_{IN} < 2.75$ V			1	μA
Output Logic Levels V_{OL} SDA, ALERT, THERM	$V_{DD} > 2$ V, $I_{OL} = 3$ mA	0		0.4	V
	$V_{DD} < 2$ V, $I_{OL} = 3$ mA	0		$0.2 \times V_{DD}$	V

Theory of Operation

The NCT203 is an on-chip temperature sensor and over/under temperature alarm. When the NCT203 is operating normally, the on-board ADC operates in a free running mode. The ADC digitizes the signals from the temperature sensor and the results are stored in the temperature value register.

The measurement results are compared with the corresponding high, low, and THERM temperature limits, stored in the on-chip registers. Out-of-limit comparisons generate flags that are stored in the status register. A result that exceeds the high temperature limit or the low temperature limit causes the ALERT output to assert. Exceeding the THERM temperature limits causes the THERM output to assert low. The ALERT output can be reprogrammed as a second THERM output.

The limit registers are programmed and the device controlled and configured via the serial I²C. The contents of any register are also read back via the I²C. Control and configuration functions consist of switching the device between normal operation and standby mode, selecting the temperature measurement range, masking or enabling the ALERT output, switching Pin 6 between ALERT and THERM2, and selecting the conversion rate.

Temperature Measurement Method

A simple method of measuring temperature is to exploit the negative temperature coefficient of a diode, measuring the base emitter voltage (V_{BE}) of a transistor operated at constant current. However, this technique requires calibration to null the effect of the absolute value of V_{BE} , which varies from device to device.

The technique used in the NCT203 measures the change in V_{BE} when the device operates at different currents.

To measure ΔV_{BE} , the operating current through the sensor is switched among related currents. $N1 \times I$ and $N2 \times I$ are different multiples of the current, I . The currents through the temperature diode are switched between I and $N1 \times I$, giving ΔV_{BE1} ; and then between I and $N2 \times I$, giving ΔV_{BE2} . The temperature is then calculated using the two ΔV_{BE} measurements.

The resulting ΔV_{BE} waveforms are passed through a 65 kHz low-pass filter to remove noise and then to a chopper-stabilized amplifier. This amplifies and rectifies the waveform to produce a dc voltage proportional to ΔV_{BE} . The ADC digitizes this voltage producing a temperature

measurement. To reduce the effects of noise, digital filtering is performed by averaging the results of 16 measurement cycles for low conversion rates. At rates of 16-, 32- and 64-conversions/second, no digital averaging occurs. Signal conditioning and measurement of the internal temperature sensor are performed in the same manner.

Temperature Measurement Results

The results of the temperature measurement are stored in the temperature value register and compared with limits programmed into the high and low limit registers.

The temperature value is in Register 0x00 and has a resolution of 1°C.

Temperature Measurement Range

The temperature measurement range is, by default, 0°C to +127°C. However, the NCT203 can be operated using an extended temperature range. The extended measurement range is -64°C to +191°C. Therefore, the NCT203 can be used to measure the full temperature range of the NCT203, from -40°C to +125°C.

The extended temperature range is selected by setting Bit 2 of the configuration register to 1. The temperature range is 0°C to 127°C when Bit 2 equals 0. A valid result is available in the next measurement cycle after changing the temperature range.

In extended temperature mode, the upper and lower temperature that can be measured by the NCT203 is limited by the device temperature range of -40°C to +125°C. The temperature register can have values from -64°C to +191°C.

It should be noted that although temperature measurements can be made while the part is in extended temperature mode, the NCT203 should not be exposed to temperatures greater than those specified in the absolute maximum ratings section. Further, the device is only guaranteed to operate as specified at ambient temperatures from -40°C to +125°C.

Temperature Data Format

The NCT203 has two temperature data formats. When the temperature measurement range is from 0°C to 127°C (default), the temperature data format for temperature results is binary. When the measurement range is in extended mode, an offset binary data format is used. Temperature values are offset by 64°C in the offset binary data format. Examples of temperatures in both data formats are shown in Table 5.

Table 5. TEMPERATURE DATA FORMAT

Temperature	Binary	Offset Binary (Note 1)
-55°C	0 000 0000 (Note 2)	0 000 1001
0°C	0 000 0000	0 100 0000
+1°C	0 000 0001	0 100 0001
+10°C	0 000 1010	0 100 1010
+25°C	0 001 1001	0 101 1001
+50°C	0 011 0010	0 111 0010
+75°C	0 100 1011	1 000 1011
+100°C	0 110 0100	1 010 0100
+125°C	0 111 1101	1 011 1101
+127°C	0 111 1111	1 011 1111
+150°C	0 111 1111 (Note 3)	1 101 0110

1. Offset binary scale temperature values are offset by 64°C.
2. Binary scale temperature measurement returns 0°C for all temperatures < 0°C.
3. Binary scale temperature measurement returns 127°C for all temperatures > 127°C.

The user can switch between measurement ranges at any time. Switching the range likewise switches the data format. The next temperature result following the switching is reported back to the register in the new format. However, the contents of the limit registers do not change. It is up to the user to ensure that when the data format changes, the limit registers are reprogrammed as necessary. More information on this is found in the Limit Registers section.

NCT203 Registers

The NCT203 contains 12, 8-bit registers in total. These registers store the results of the temperature measurement, high and low temperature limits, and configure and control the device. See the Address Pointer Register section through the Consecutive ALERT Register section of this data sheet for more information on the NCT203 registers. Additional details are shown in Table 6 through Table 9. The entire register map is available in Table 10.

Address Pointer Register

The address pointer register itself does not have, nor does it require, an address because the first byte of every write operation is automatically written to this register. The data in this first byte always contains the address of another register on the NCT203 that is stored in the address pointer register. It is to this register address that the second byte of a write operation is written, or to which a subsequent read operation is performed.

The power-on default value of the address pointer register is 0x00. Therefore, if a read operation is performed immediately after power-on, without first writing to the address pointer, the value of the temperature is returned because its register address is 0x00.

Temperature Value Register

The NCT203 has a temperature register to store the results of temperature measurement. This register can only be written to by the ADC and can be read by the user over the I²C. The temperature value register is at Address 0x00.

The power-on default for this register is 0x00.

Configuration Register

The configuration register is Address 0x03 at read and Address 0x09 at write. Its power-on default is 0x00. Only four bits of the configuration register are used. Bit 0, Bit 1, Bit 3, and Bit 4 are reserved; only zeros should be written to these.

Bit 7 of the configuration register masks the ALERT output. If Bit 7 is 0, the ALERT output is enabled. This is the power-on default. If Bit 7 is set to 1, the ALERT output is disabled. This applies only if Pin 6 is configured as ALERT. If Pin 6 is configured as THERM2, then the value of Bit 7 has no effect.

If Bit 6 is set to 0, which is power-on default, the device is in operating mode with ADC converting. If Bit 6 is set to 1, the device is in standby mode and the ADC does not convert. The I²C does, however, remain active in standby mode; therefore, values can be read from or written to the NCT203 via the I²C. The ALERT and THERM output are also active in standby mode. Changes made to the register in standby mode that affect the THERM or ALERT outputs cause these signals to be updated.

Bit 5 determines the configuration of Pin 6 on the NCT203. If Bit 5 is 0 (default), then Pin 6 is configured as a ALERT output. If Bit 5 is 1, then Pin 6 is configured as a THERM2 output. Bit 7, the ALERT mask bit, is only active when Pin 6 is configured as an ALERT output. If Pin 6 is set up as a THERM2 output, then Bit 7 has no effect.

Bit 2 sets the temperature measurement range. If Bit 2 is 0 (default value), the temperature measurement range is set between 0°C to +127°C. Setting Bit 2 to 1 sets the measurement range to the extended temperature range (-64°C to +191°C).

Table 6. CONFIGURATION REGISTER BIT ASSIGNMENTS

Bit	Name	Function	Power-On Default
7	MASK1	0 = <u>ALERT</u> Enabled 1 = <u>ALERT</u> Masked	0
6	RUN/STOP	0 = Run 1 = Standby	0
5	<u>ALERT</u> / <u>THERM2</u>	0 = <u>ALERT</u> 1 = <u>THERM2</u>	0
4, 3	Reserved		0
2	Temperature Range Select	0 = 0°C to 127°C 1 = Extended Range	0
1, 0	Reserved		0

Conversion Rate Register

The conversion rate register is Address 0x04 at read and Address 0x0A at write. The lowest four bits of this register are used to program the conversion rate by dividing the internal oscillator clock by 1, 2, 4, 8, 16, 32, 64, 128, 256, 512, 1024 to give conversion times from 15.5 ms (Code 0x0A) to 16 seconds (Code 0x00). For example, a conversion rate of eight conversions per second means that beginning at 125 ms intervals, the device performs a conversion on the internal temperature channel.

The conversion rate register can be written to and read back over the I²C. The higher four bits of this register are unused and must be set to 0. The default value of this register is 0x08, giving a rate of 16 conversions per second. Use of slower conversion times greatly reduces the device power consumption.

Table 7. CONVERSION RATES

Code	Conversion/Second	Time (Seconds)
0x00	0.0625	16
0x01	0.125	8
0x02	0.25	4
0x03	0.5	2
0x04	1	1
0x05	2	500 m
0x06	4	250 m
0x07	8	125 m
0x08	16	62.5 m
0x09	32	31.25 m
0x0A	64	15.5 m
0x0B to 0xFF	Reserved	

Limit Registers

The NCT203 has three limit registers: high, low, and $\overline{\text{THERM}}$ temperature limits for temperature measurements. There is also a $\overline{\text{THERM}}$ hysteresis register. All limit registers can be written to, and read byck over I²C. See Table 9 for details of the limit register addresses and their power-on default values.

When Pin 6 is configured as an $\overline{\text{ALERT}}$ output, the high limit registers perform a > comparison, while the low limit registers perform a ≤ comparison. For example, if the high limit register is programmed with 80°C, then measuring 81°C results in an out-of-limit condition, setting a flag in the status register. If the low limit register is programmed with 0°C, measuring 0°C or lower results in an out-of-limit condition.

Exceeding the $\overline{\text{THERM}}$ limit asserts $\overline{\text{THERM}}$ low. When Pin 6 is configured as $\overline{\text{THERM2}}$, exceeding the high limit asserts $\overline{\text{THERM2}}$ low. A default hysteresis value of 10°C is

provided which applies to both $\overline{\text{THERM}}$ channels. This hysteresis value can be reprogrammed to any value after powerup (Register Address 0x21).

It is important to remember that the temperature limits data format is the same as the temperature measurement data format. Therefore, if the temperature measurement uses default binary, then the temperature limits also use the binary scale. If the temperature measurement scale is switched, however, the temperature limits do not automatically switch. The user must reprogram the limit registers to the desired value in the correct data format. For example, if the low limit is set at 10°C with the default binary scale, the limit register value is 0000 1010b. If the scale is switched to offset binary, the value in the low temperature limit register needs to be reprogrammed to 0100 1010b.

Status Register

The status register is a read-only register at Address 0x02. It contains status information for the NCT203. When Bit 7 of the status register is high, it indicates that the ADC is busy converting. The other bits in this register flag the out-of-limit temperature measurements (Bit 6 to Bit 3, and Bit 1 to Bit 0).

If Pin 6 is configured as an $\overline{\text{ALERT}}$ output, the following applies: If the temperature measurement exceeds its limits, Bit 6 (high limit) or Bit 5 (low limit) of the status register asserts to flag this condition. These flags are NOR'ed together, so if any of them is high, the $\overline{\text{ALERT}}$ interrupt latch is set and the ALERT output goes low.

Reading the status register clears the flags, Bit 6 to Bit 2, provided the error conditions causing the flags to be set have gone away. A flag bit can be reset only if the corresponding value register contains an in-limit measurement or if the sensor is good.

The $\overline{\text{ALERT}}$ interrupt latch (output) is reset by either reading the status register or by issuing the device with an ARA. In order for either of the above to work the error condition must have gone away.

When Flag 0 is set, the $\overline{\text{THERM}}$ output goes low to indicate that the temperature measurement is outside the programmed limits. The $\overline{\text{THERM}}$ output does not need to be reset, unlike the $\overline{\text{ALERT}}$ output. Once the measurements are within the limits, the corresponding status register bits are automatically reset and the $\overline{\text{THERM}}$ output goes high. The user may add hysteresis by programming Register 0x21. The $\overline{\text{THERM}}$ output is reset only when the temperature falls to limit value minus the hysteresis value.

When Pin 6 is configured as $\overline{\text{THERM2}}$, only the high temperature limits are relevant. If Flag 6 is set, the $\overline{\text{THERM2}}$ output goes low to indicate that the temperature measurement is outside the programmed limits. Flag 5 has no effect on $\overline{\text{THERM2}}$. The behavior of $\overline{\text{THERM2}}$ is otherwise the same as $\overline{\text{THERM}}$.

Table 8. STATUS REGISTER BIT ASSIGNMENTS

Bit	Name	Function
7	BUSY	1 when ADC is converting
6	HIGH (Note 4)	1 when high temperature limit is tripped
5	LOW (Note 4)	1 when low temperature limit is tripped
4	Reserved	
3	Reserved	
2	Reserved	
1	Reserved	
0	THRM	1 when THERM limit is tripped

4. These flags stay high until the status register is read or they are reset by POR unless Pin 6 is configured as THERM2. Then, only Bit 2 remains high until the status register is read or is reset by POR.

One-Shot Register

The one-shot register is used to initiate a conversion and comparison cycle when the NCT203 is in standby mode, after which the device returns to standby. Writing to the one-shot register address (0x0F) causes the NCT203 to perform a conversion and comparison on the temperature. This is not a data register as such, and it is the write operation to Address 0x0F that causes the one-shot conversion. The data written to this address is irrelevant and is not stored.

Table 10. LIST OF REGISTERS

Read Address (Hex)	Write Address (Hex)	Name	Power-On Default
Not Applicable	Not Applicable	Address Pointer	Undefined
00	Not Applicable	Temperature Value	0000 0000 (0x00)
02	Not Applicable	Status	Undefined
03	09	Configuration	0000 0000 (0x00)
04	0A	Conversion Rate	0000 1000 (0x08)
05	0B	Temperature High Limit	0101 0101 (0x55) (85°C)
06	0C	Temperature Low Limit	0000 0000 (0x00) (0°C)
Not Applicable	0F (Note 1)	One-Shot	
20	20	THERM Limit	0101 0101 (0x55) (85°C)
21	21	THERM Hysteresis	0000 1010 (0x0A) (0x10°C)
22	22	Consecutive ALERT	0000 0001 (0x01)
FE	Not Applicable	Manufacturer ID	0001 1010 (0x1A)
FF	Not Applicable	Die Revision Code	0xXX

Consecutive ALERT Register

The value written to this register determines how many out-of-limit measurements must occur before an ALERT is generated. The default value is that one out-of-limit measurement generates an ALERT. The maximum value that can be chosen is 4. The purpose of this register is to allow the user to perform some filtering of the output. This is particularly useful at the fastest three conversion rates, where no averaging takes place. This register is at Address 0x22.

Table 9. CONSECUTIVE ALERT REGISTER CODES

Register Value	Number of Out-of-Limit Measurements Required
yxxx 000x	1
yxxx 001x	2
yxxx 011x	3
yxxx 111x	4

Note: x = don't care bits, and y = Bus timeout bit. Default = 0. See interface section for more information.

SERIAL INTERFACE

Control of the NCT203 is carried out via the I²C compatible serial interface. The NCT203 is connected to this bus as a slave device, under the control of a master device.

The NCT203 has a bus timeout feature. When this is enabled, the bus times out after typically 25 ms of no activity. After this time, the NCT203 resets the SDA line back to its idle state (high impedance) and waits for the next start condition. However, this feature is not enabled by default. Bit 7 of the consecutive alert register (Address = 0x22) should be set to enable it.

Addressing the Device

In general, every I²C device has a 7-bit device address, except for some devices that have extended 10-bit addresses. When the master device sends a device address over the bus, the slave device with that address responds. The NCT203 is available with one device address, 0x4C. For systems requiring more than one NCT203, another address option will be required. Please contact your local ON Semiconductor representative for more information.

The serial bus protocol operates as follows:

1. The master initiates data transfer by establishing a start condition, defined as a high to low transition on the serial data line SDA, while the serial clock line SCL remains high. This indicates that an address/data stream is going to follow. All slave peripherals connected to the serial bus respond to the start condition and shift in the next eight bits, consisting of a 7-bit address (MSB first) plus a read/write (R/W) bit, which determines the direction of the data transfer i.e. whether data is written to, or read from, the slave device. The peripheral with the address corresponding to the transmitted address responds by pulling the data line low during the low period before the ninth clock pulse, known as the acknowledge bit. All other devices on the bus now remain idle while the selected device waits for data to be read from or written to it. If the R/W bit is a zero then the master writes to the slave device. If the R/W bit is a one then the master reads from the slave device.
2. Data is sent over the serial bus in sequences of nine clock pulses, eight bits of data followed by an acknowledge bit from the receiver of data. Transitions on the data line must occur during the low period of the clock signal and remain stable during the high period, since a low-to-high transition when the clock is high can be interpreted as a stop signal.
3. When all data bytes have been read or written, stop conditions are established. In write mode, the master pulls the data line high during the tenth clock pulse to assert a stop condition. In read

mode, the master overrides the acknowledge bit by pulling the data line high during the low period before the ninth clock pulse. This is known as no acknowledge. The master takes the data line low during the low period before the tenth clock pulse, then high during the tenth clock pulse to assert a stop condition.

To write data to one of the device data registers, or to read data from it, the address pointer register must be set so that the correct data register is addressed. The first byte of a write operation always contains a valid address that is stored in the address pointer register. If data is to be written to the device, the write operation contains a second data byte that is written to the register selected by the address pointer register.

This procedure is illustrated in Figure 4. The device address is sent over the bus followed by R/W set to 0. This is followed by two data bytes. The first data byte is the address of the internal data register to be written to, which is stored in the address pointer register. The second data byte is the data to be written to the internal data register.

When reading data from a register there are two possibilities.

- If the address pointer register value of the NCT203 is unknown or not the desired value, it is first necessary to set it to the correct value before data can be read from the desired data register. This is done by writing to the NCT203 as before, but only the data byte containing the register read address is sent, because data is not to be written to the register see Figure 4. A read operation is then performed consisting of the serial bus address, R/W bit set to 1, followed by the data byte read from the data register see Figure 6.
- If the address pointer register is known to be at the desired address, data can be read from the corresponding data register without first writing to the address pointer register and the bus transaction shown in Figure 5 can be omitted.

Notes:

- It is possible to read a data byte from a data register without first writing to the address pointer register. However, if the address pointer register is already at the correct value, it is not possible to write data to a register without writing to the address pointer register because the first data byte of a write is always written to the address pointer register.
- Some of the registers have different addresses for read and write operations. The write address of a register must be written to the address pointer if data is to be written to that register, but it may not be possible to read data from that address. The read address of a register must be written to the address pointer before data can be read from that register.

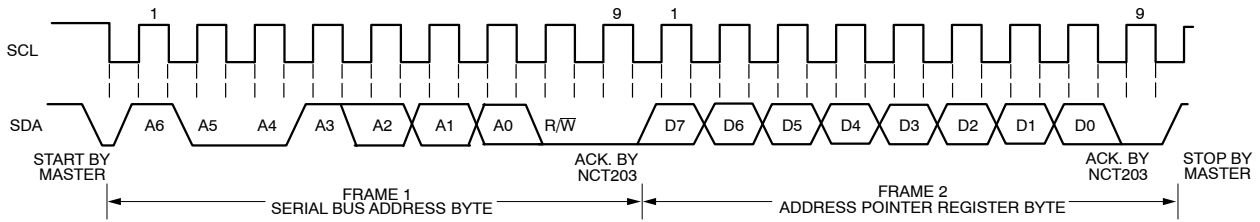

Figure 4. Writing to the Address Pointer Register

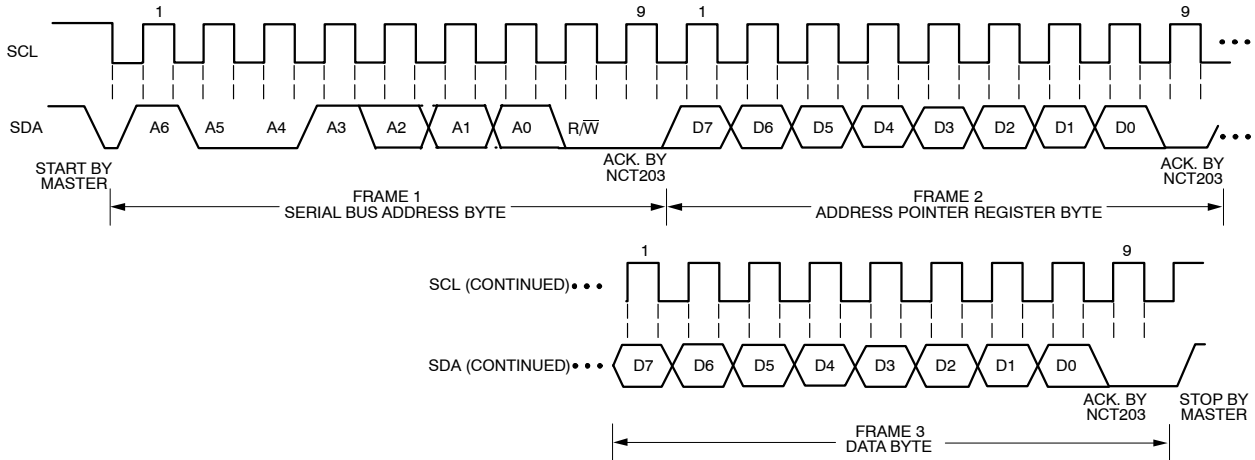

Figure 5. Writing a Register Address to the Address Pointer Register, then Writing a Single Byte of Data to a Register

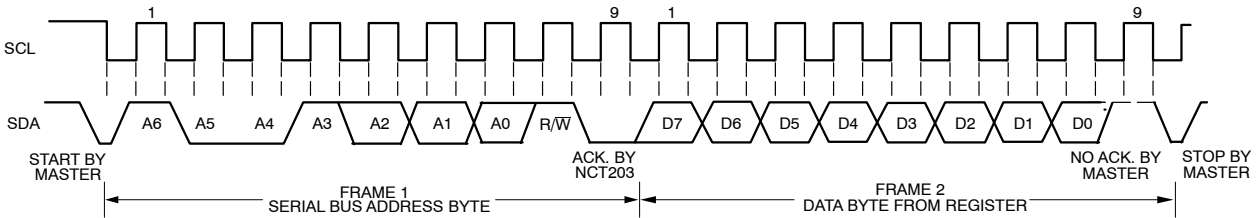

Figure 6. Reading a Byte of Data from a Register

ALERT Output

This is applicable when Pin 6 is configured as an $\overline{\text{ALERT}}$ output. The $\overline{\text{ALERT}}$ output goes low whenever an out-of-limit measurement is detected. It is an open-drain output and requires a pullup resistor to V_{DD} . Several $\overline{\text{ALERT}}$ outputs can be wire-OR'ed together, so that the common line goes low if one or more of the $\overline{\text{ALERT}}$ outputs goes low.

The $\overline{\text{ALERT}}$ output can be used as an interrupt signal to a processor, or as an $\overline{\text{SMBALERT}}$. Slave devices on the bus cannot normally signal to the bus master that they want to talk, but the $\overline{\text{SMBALERT}}$ function allows them to do so.

One or more $\overline{\text{ALERT}}$ outputs can be connected to a common $\overline{\text{SMBALERT}}$ line that is connected to the master. When the $\overline{\text{SMBALERT}}$ line is pulled low by one of the devices, the following procedure occurs (see Figure 7):

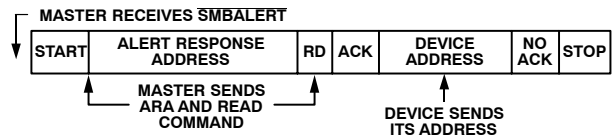

Figure 7. Use of $\overline{\text{SMBALERT}}$

1. $\overline{\text{SMBALERT}}$ is pulled low.
2. Master initiates a read operation and sends the alert response address (ARA = 0001 100). This is a general call address that must not be used as a specific device address.
3. The device whose $\overline{\text{ALERT}}$ output is low responds to the alert response address and the master reads its device address. As the device address is seven bits, an LSB of 1 is added. The address of the device is now known and it can be interrogated in the usual way.
4. If more than one device's $\overline{\text{ALERT}}$ output is low, the one with the lowest device address takes

priority, in accordance with normal bus arbitration. Once the NCT203 has responded to the alert response address, it resets its $\overline{\text{ALERT}}$ output, provided that the error condition that caused the $\overline{\text{ALERT}}$ no longer exists. If the $\overline{\text{SMBALERT}}$ line remains low, the master sends the $\overline{\text{ARA}}$ again, and so on until all devices whose $\overline{\text{ALERT}}$ outputs were low have responded.

Low Power Standby Mode

The NCT203 can be put into low power standby mode by setting Bit 6 of the configuration register. When Bit 6 is low, the NCT203 operates normally. When Bit 6 is high, the ADC is inhibited, and any conversion in progress is terminated without writing the result to the corresponding value register. However, the I^2C is still enabled. Power consumption in the standby mode is reduced to 15 μA if there is no bus activity.

When the device is in standby mode, it is possible to initiate a one-shot conversion by writing to the one-shot register (Address 0x0F), after which the device returns to standby. It does not matter what is written to the one-shot register, all data written to it is ignored. It is also possible to write new values to the limit register while in standby mode. If the value stored in the temperature value register is outside the new limits, an $\overline{\text{ALERT}}$ is generated, even though the NCT203 is still in standby.

The NCT203 Interrupt System

The NCT203 has two interrupt outputs, $\overline{\text{ALERT}}$ and $\overline{\text{THERM}}$. Both have different functions and behavior. $\overline{\text{ALERT}}$ is maskable and responds to violations of software programmed temperature limits. $\overline{\text{THERM}}$ is intended as a fail-safe interrupt output that cannot be masked.

If the temperature exceeds the programmed high temperature limits, or equals or exceeds the low temperature limits, the $\overline{\text{ALERT}}$ output is asserted low. $\overline{\text{ALERT}}$ is reset when serviced by a master reading its device address, provided the error condition has gone away and the status register has been reset.

The $\overline{\text{THERM}}$ output asserts low if the temperature exceeds the programmed $\overline{\text{THERM}}$ limits. $\overline{\text{THERM}}$ temperature limits should normally be equal to or greater than the high temperature limits. $\overline{\text{THERM}}$ is reset automatically when the temperature falls back within the $\overline{\text{THERM}}$ limit. A hysteresis value can be programmed; in which case, $\overline{\text{THERM}}$ resets when the temperature falls to the limit value minus the hysteresis value. The power-on hysteresis default value is 10°C, but this can be reprogrammed to any value after powerup.

The hysteresis loop on the $\overline{\text{THERM}}$ outputs is useful when $\overline{\text{THERM}}$ is used, for example, as an on/off controller for a fan. The user's system can be set up so that when $\overline{\text{THERM}}$ asserts, a fan is switched on to cool the system. When $\overline{\text{THERM}}$ goes high again, the fan can be switched off. Programming a hysteresis value protects from fan jitter,

where the temperature hovers around the $\overline{\text{THERM}}$ limit, and the fan is constantly switched.

Table 11. $\overline{\text{THERM}}$ HYSTERESIS

$\overline{\text{THERM}}$ Hysteresis	Binary Representation
0°C	0 000 0000
1°C	0 000 0001
10°C	0 000 1010

Figure 8 shows how the $\overline{\text{THERM}}$ and $\overline{\text{ALERT}}$ outputs operate. The $\overline{\text{ALERT}}$ output can be used as a $\overline{\text{SMBALERT}}$ to signal to the host via the I^2C that the temperature has risen. The user can use the $\overline{\text{THERM}}$ output to turn on a fan to cool the system, if the temperature continues to increase. This method ensures that there is a fail-safe mechanism to cool the system, without the need for host intervention.

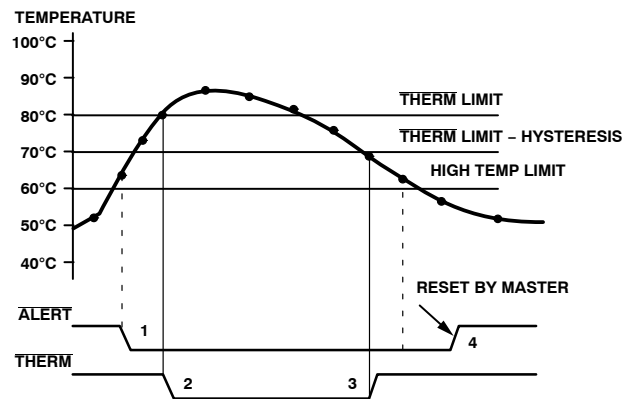

Figure 8. Operation of the $\overline{\text{ALERT}}$ and $\overline{\text{THERM}}$ Interrupts

- If the measured temperature exceeds the high temperature limit, the $\overline{\text{ALERT}}$ output asserts low.
- If the temperature continues to increase and exceeds the $\overline{\text{THERM}}$ limit, the $\overline{\text{THERM}}$ output asserts low. This can be used to throttle the CPU clock or switch on a fan.
- The $\overline{\text{THERM}}$ output deasserts (goes high) when the temperature falls to $\overline{\text{THERM}}$ limit minus hysteresis. The default hysteresis value is 10°C.
- The $\overline{\text{ALERT}}$ output deasserts only when the temperature has fallen below the high temperature limit, and the master has read the device address and cleared the status register.
- Pin 6 on the NCT203 can be configured as either an $\overline{\text{ALERT}}$ output or as an additional $\overline{\text{THERM}}$ output.
- $\overline{\text{THERM2}}$ asserts low when the temperature exceeds the programmed high temperature limits. It is reset in the same manner as $\overline{\text{THERM}}$ and is not maskable.
- The programmed hysteresis value also applies to $\overline{\text{THERM2}}$.

Figure 9 shows how $\overline{\text{THERM}}$ and $\overline{\text{THERM2}}$ operate together to implement two methods of cooling the system.

In this example, the $\overline{\text{THERM2}}$ limits are set lower than the $\overline{\text{THERM}}$ limits. The $\overline{\text{THERM2}}$ output is used to turn on a fan. If the temperature continues to rise and exceeds the $\overline{\text{THERM}}$ limits, the $\overline{\text{THERM}}$ output provides additional cooling by throttling the CPU.

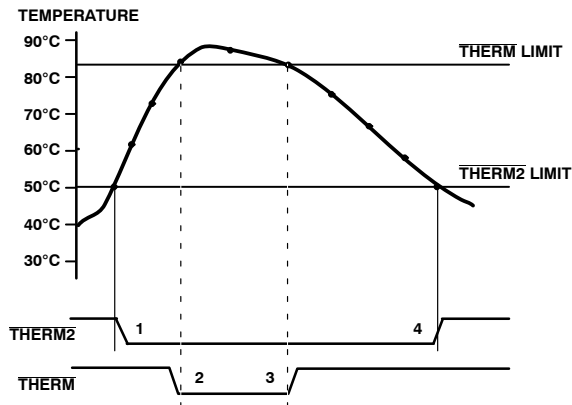

Figure 9. Operation of the $\overline{\text{THERM}}$ and $\overline{\text{THERM2}}$ Interrupts

- When the $\overline{\text{THERM2}}$ limit is exceeded, the $\overline{\text{THERM2}}$ signal asserts low.
- If the temperature continues to increase and exceeds the $\overline{\text{THERM}}$ limit, the $\overline{\text{THERM}}$ output asserts low.
- The $\overline{\text{THERM}}$ output deasserts (goes high) when the temperature falls to $\overline{\text{THERM}}$ limit minus hysteresis. In Figure 9, there is no hysteresis value shown.
- As the system cools further, and the temperature falls below the $\overline{\text{THERM2}}$ limit, the $\overline{\text{THERM2}}$ signal resets. Again, no hysteresis value is shown for $\overline{\text{THERM2}}$.

Power Supply Rise Time

When powering up the NCT203 you must ensure that the power supply voltage rises above 1.32 in less than 5 ms. If a rise time of longer than this occurs then power-on-reset will be caused and yield unpredictable results.

NCT203

Table 12. ORDERING INFORMATION

Device Number	Package	Shipping†
NCT203MTR2G	DFN8 (Pb-Free)	3000 / Tape and Reel

†For information on tape and reel specifications, including part orientation and tape sizes, please refer to our Tape and Reel Packaging Specifications Brochure, BRD8011/D.

PACKAGE DIMENSIONS

WDFN8 2x1.8, 0.5P
CASE 511BU
ISSUE O

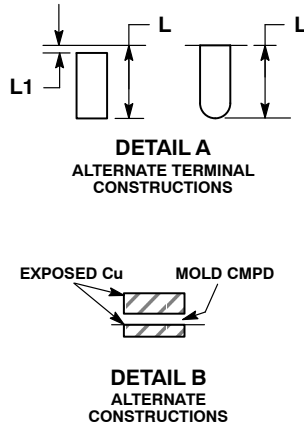
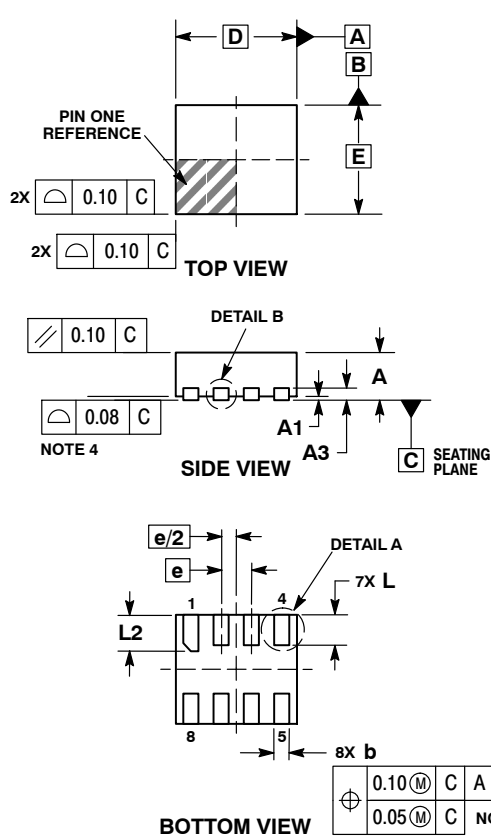

NOTES:

1. DIMENSIONING AND TOLERANCING PER ASME Y14.5M, 1994.
2. CONTROLLING DIMENSION: MILLIMETERS.
3. DIMENSION b APPLIES TO PLATED TERMINAL AND IS MEASURED BETWEEN 0.15 AND 0.20 MM FROM TERMINAL TIP.
4. COPLANARITY APPLIES TO THE EXPOSED PAD AS WELL AS THE TERMINALS.

DIM	MILLIMETERS	
	MIN	MAX
A	0.70	0.80
A1	0.00	0.05
A3	0.20 REF	
b	0.20	0.30
D	2.00 BSC	
E	1.80 BSC	
e	0.50 BSC	
L	0.45	0.55
L1	---	0.15
L2	0.55	0.65

RECOMMENDED SOLDERING FOOTPRINT*

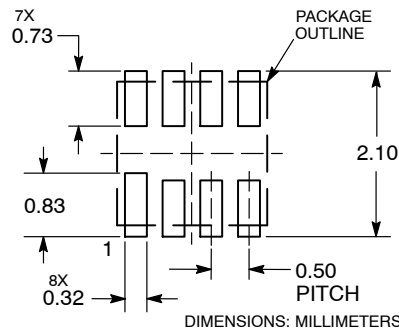

*For additional information on our Pb-Free strategy and soldering details, please download the ON Semiconductor Soldering and Mounting Techniques Reference Manual, SOLDERRM/D.

ON Semiconductor and **ON** are registered trademarks of Semiconductor Components Industries, LLC (SCILLC). SCILLC owns the rights to a number of patents, trademarks, copyrights, trade secrets, and other intellectual property. A listing of SCILLC's product/patent coverage may be accessed at www.onsemi.com/site/pdf/Patent-Marketing.pdf. SCILLC reserves the right to make changes without further notice to any products herein. SCILLC makes no warranty, representation or guarantee regarding the suitability of its products for any particular purpose, nor does SCILLC assume any liability arising out of the application or use of any product or circuit, and specifically disclaims any and all liability, including without limitation special, consequential or incidental damages. "Typical" parameters which may be provided in SCILLC data sheets and/or specifications can and do vary in different applications and actual performance may vary over time. All operating parameters, including "Typicals" must be validated for each customer application by customer's technical experts. SCILLC does not convey any license under its patent rights nor the rights of others. SCILLC products are not designed, intended, or authorized for use as components in systems intended for surgical implant into the body, or other applications intended to support or sustain life, or for any other application in which the failure of the SCILLC product could create a situation where personal injury or death may occur. Should Buyer purchase or use SCILLC products for any such unintended or unauthorized application, Buyer shall indemnify and hold SCILLC and its officers, employees, subsidiaries, affiliates, and distributors harmless against all claims, costs, damages, and expenses, and reasonable attorney fees arising out of, directly or indirectly, any claim of personal injury or death associated with such unintended or unauthorized use, even if such claim alleges that SCILLC was negligent regarding the design or manufacture of the part. SCILLC is an Equal Opportunity/Affirmative Action Employer. This literature is subject to all applicable copyright laws and is not for resale in any manner.

PUBLICATION ORDERING INFORMATION

LITERATURE FULFILLMENT:
Literature Distribution Center for ON Semiconductor
P.O. Box 5163, Denver, Colorado 80217 USA
Phone: 303-675-2175 or 800-344-3860 Toll Free USA/Canada
Fax: 303-675-2176 or 800-344-3867 Toll Free USA/Canada
Email: orderlit@onsemi.com

N. American Technical Support: 800-282-9855 Toll Free
USA/Canada
Europe, Middle East and Africa Technical Support:
Phone: 421 33 790 2910
Japan Customer Focus Center
Phone: 81-3-5817-1050

ON Semiconductor Website: www.onsemi.com
Order Literature: <http://www.onsemi.com/orderlit>
For additional information, please contact your local Sales Representative