



Chipsmall Limited consists of a professional team with an average of over 10 year of expertise in the distribution of electronic components. Based in Hongkong, we have already established firm and mutual-benefit business relationships with customers from,Europe,America and south Asia,supplying obsolete and hard-to-find components to meet their specific needs.

With the principle of “Quality Parts,Customers Priority,Honest Operation,and Considerate Service”,our business mainly focus on the distribution of electronic components. Line cards we deal with include Microchip,ALPS,ROHM,Xilinx,Pulse,ON,Everlight and Freescale. Main products comprise IC,Modules,Potentiometer,IC Socket,Relay,Connector.Our parts cover such applications as commercial,industrial, and automotives areas.

We are looking forward to setting up business relationship with you and hope to provide you with the best service and solution. Let us make a better world for our industry!



## Contact us

Tel: +86-755-8981 8866 Fax: +86-755-8427 6832

Email & Skype: info@chipsmall.com Web: www.chipsmall.com

Address: A1208, Overseas Decoration Building, #122 Zhenhua RD., Futian, Shenzhen, China



# NCT210

## Low Cost Microprocessor System Temperature Monitor Microcomputer

The NCT210 is a two-channel digital thermometer and under/overtemperature alarm, intended for use in personal computers and other systems requiring thermal monitoring and management. The device can measure the temperature of a microprocessor using a diode-connected PNP transistor, which can be provided on-chip with the processor, or can be a low cost discrete NPN/PNP device, such as the 2N3904/2N3906. A novel measurement technique cancels out the absolute value of the transistor's base emitter voltage so that no calibration is required. The second measurement channel measures the output of an on-chip temperature sensor to monitor the temperature of the device and its environment.

The NCT210 communicates over a two-wire serial interface compatible with SMBus standards. Under/overtemperature limits can be programmed into the device over the serial bus, and an  $\overline{\text{ALERT}}$  output signals when the on-chip or remote temperature is out of range. This output can be used as an interrupt or as an SMBus alert.

### Features

- Alternative to the ADM1021A
- On-chip and Remote Temperature Sensing
- No Calibration Necessary
- 1°C Accuracy for On-chip Sensor
- 3°C Accuracy for Remote Sensor
- Programmable Over/Undertemperature Limits
- Programmable Conversion rate
- 2-wire SMBus Serial Interface
- Supports System Management Bus (SMBus) Alert
- 200  $\mu\text{A}$  Max Operating Current
- 1  $\mu\text{A}$  Standby Current
- 3.0 V to 5.5 V Supply
- Small 16-lead QSOP Package
- This Device is Pb-Free, Halogen Free and is RoHS Compliant

### Applications

- Desktop Computers
- Notebook Computers
- Smart Batteries
- Industrial Controllers
- Telecom Equipment
- Instrumentation



ON Semiconductor®

<http://onsemi.com>

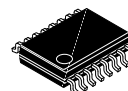

QSOP-16  
CASE 492

### PIN ASSIGNMENT

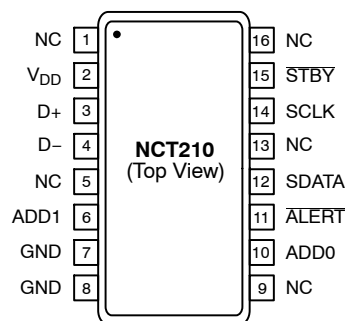

NC = No Connect

### MARKING DIAGRAM

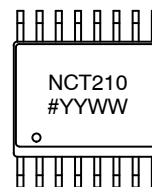

NCT210 = Specific Device Code  
# = Pb-Free Package  
YYWW = Date Code

### ORDERING INFORMATION

See detailed ordering and shipping information in the package dimensions section on page 14 of this data sheet.

# NCT210

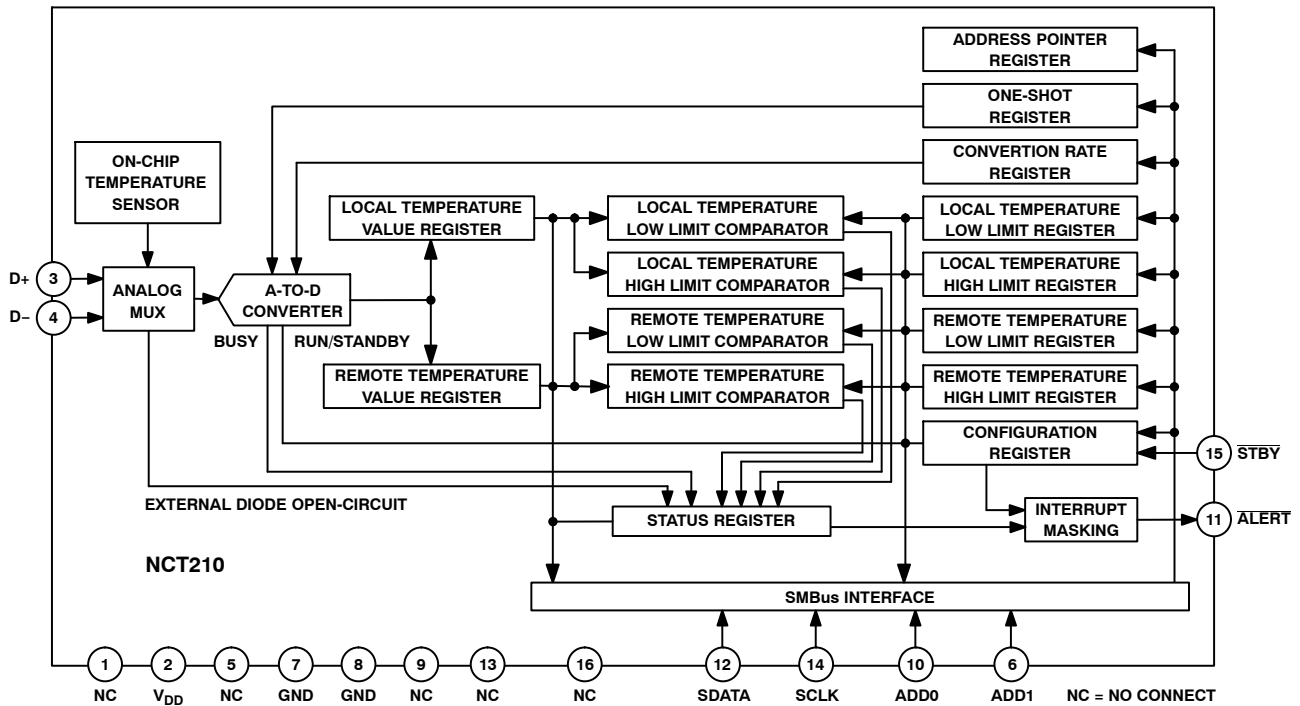

Figure 1. Functional Block Diagram

Table 1. PIN ASSIGNMENT

Pin No.	Mnemonic	Description
1	NC	No Connect
2	V <sub>DD</sub>	Positive Supply, 3.0 V to 5.5 V
3	D+	Positive Connection to Remote Temperature Sensor
4	D-	Negative Connection to Remote Temperature Sensor
5	NC	No Connect
6	ADD1	Three-state Logic Input, Higher Bit of Device Address
7	GND	Supply 0 V Connection
8	GND	Supply 0 V Connection
9	NC	No Connect
10	ADD0	Three-state Logic Input, Lower Bit of Device Address
11	ALERT	Open-drain Logic Output Used as Interrupt or SMBus ALERT
12	SDATA	Logic Input/Output, SMBus Serial Data. Open-drain Output
13	NC	No Connect
14	SCLK	Logic Input, SMBus Serial Clock
15	STBY	Logic Input Selecting Normal Operation (High) or Standby Mode (Low)
16	NC	No Connect

# NCT210

**Table 2. ABSOLUTE MAXIMUM RATINGS**

Parameter	Rating	Unit
Positive Supply Voltage ( $V_{DD}$ ) to GND	-0.3 to +6.0	V
D+, ADD0, ADD1	-0.3 to $V_{DD} + 0.3$	V
D- to GND	-0.3 to +0.6	
SCLK, SDATA, ALERT, STBY	-0.3 to +6.0	V
Input Current	$\pm 50$	mA
Input Current, D-	$\pm 1$	mA
ESD Rating, All Pins (Human Body Model)	2,000	V
Continuous Power Dissipation Up to 70°C Derating Above 70°C	650 6.7	mW mW/°C
Operating Temperature Range	-55 to +125	°C
Maximum Junction Temperature ( $T_{J\ MAX}$ )	150	°C
Storage Temperature Range	-65 to +150	°C
Lead Temperature, Soldering (10 sec)	300	°C
IR Reflow Peak Temperature	220	°C

Stresses exceeding Maximum Ratings may damage the device. Maximum Ratings are stress ratings only. Functional operation above the Recommended Operating Conditions is not implied. Extended exposure to stresses above the Recommended Operating Conditions may affect device reliability.

NOTE: This device is ESD sensitive. Use standard ESD precautions when handling.

**Table 3. THERMAL CHARACTERISTICS**

Package Type	$\theta_{JA}$	Unit
16-lead QSOP Package	105	°C/W

**Table 4. ELECTRICAL CHARACTERISTICS**

( $T_A = T_{MIN}$  to  $T_{MAX}$ ,  $V_{DD} = 3.0$  V to 3.6 V, unless otherwise noted) (Note 1)

Parameter	Test Conditions/Comments	Min	Typ	Max	Unit
<b>Power Supply and ADC</b>					
Temperature Resolution	Guaranteed No Missed Codes	1.0	-	-	°C
Temperature Error, Local Sensor		-3.0	$\pm 1.0$	+3.0	°C
Temperature Error, Remote Sensor	$T_A = 60^\circ\text{C}$ to $100^\circ\text{C}$	-3.0 -5.0	-	+3.0 +5.0	°C
Supply Voltage Range (Note 2)		3.0	-	3.6	V
Undervoltage Lockout Threshold	$V_{DD}$ Input, Disables ADC, Rising Edge	2.5	2.7	2.95	V
Undervoltage Lockout Hysteresis		-	25	-	mV
Power-on Reset Threshold	$V_{DD}$ , Falling Edge (Note 3)	0.885	1.7	2.2	V
POR Threshold Hysteresis		-	50	-	mV
Standby Supply Current	$V_{DD} = 3.3$ V, No SMBus Activity SCLK at 10 kHz	-	1.0 4.0	5.0 -	$\mu\text{A}$
Average Operating Supply Current	0.25 Conversions/Sec Rate	-	130	200	$\mu\text{A}$
Auto-convert Mode, Averaged Over 4 Sec	2 Conversions/Sec Rate	-	225	370	$\mu\text{A}$
Conversion Time	From Stop Bit to Conversion Complete (Both Channels) D+ Forced to D- + 0.65 V	65	115	170	ms
Remote Sensor Source Current	High Level (Note 3) Low Level (Note 3)	120 7.0	205 12	300 16	$\mu\text{A}$
D- Source Voltage		-	0.7	-	V
Address Pin Bias Current (ADD0, ADD1)	Momentary at Power-on Reset	-	50	-	$\mu\text{A}$

# NCT210

**Table 4. ELECTRICAL CHARACTERISTICS** (continued)

( $T_A = T_{MIN}$  to  $T_{MAX}$ ,  $V_{DD} = 3.0$  V to 3.6 V, unless otherwise noted) (Note 1)

Parameter	Test Conditions/Comments	Min	Typ	Max	Unit
<b>SMBus Interface</b> (See Figure 2)					
Logic Input High Voltage, $V_{IH}$ STBY, SCLK, SDATA	$V_{DD} = 3.0$ V to 5.5 V	2.2	–	–	V
Logic Input Low Voltage, $V_{IL}$ STBY, SCLK, SDATA	$V_{DD} = 3.0$ V to 5.5 V	–	–	0.8	V
SMBus Output Low Sink Current	SDATA Forced to 0.6 V	6.0	–	–	mA
ALERT Output Low Sink Current	ALERT Forced to 0.4 V	1.0	–	–	mA
Logic Input Current, $I_{IH}$ , $I_{IL}$		–1.0	–	+1.0	$\mu$ A
SMBus Input Capacitance, SCLK, SDATA		–	5.0	–	pF
SMBus Clock Frequency		–	–	100	kHz
SMBus Clock Low Time, $t_{LOW}$	$t_{LOW}$ between 10% Points	4.7	–	–	$\mu$ s
SMBus Clock High Time, $t_{HIGH}$	$t_{HIGH}$ between 90% Points	4.0	–	–	$\mu$ s
SMBus Start Condition Setup Time, $t_{SU:STA}$		4.7	–	–	$\mu$ s
SMBus Repeat Start Condition		250	–	–	ns
Setup Time, $t_{SU:STA}$	Between 90% and 90% Points	250	–	–	ns
SMBus Start Condition Hold Time, $t_{HD:STA}$	Time from 10% of SDATA to 90% of SCLK	4.0	–	–	$\mu$ s
SMBus Stop Condition Setup Time, $t_{SU:STO}$	Time from 90% of SCLK to 10% of SDATA	4.0	–	–	$\mu$ s
SMBus Data Valid to SCLK	Time for 10% or 90% of SDATA to 10% of SCLK	250	–	–	ns
Rising Edge Time, $t_{SU:DAT}$	Time for 10% or 90% of SDATA to 10% of SCLK	250	–	–	ns
SMBus Data Hold Time, $t_{BUF:DAT}$		0	–	–	$\mu$ s
SMBus Bus Free Time, $t_{BUF}$	Between Start/Stop Condition	4.7	–	–	$\mu$ s
SCLK Falling Edge to SDATA		–	–	1	$\mu$ s
Valid Time, $t_{VD:DAT}$	Master Clocking in Data	–	–	1	$\mu$ s

1.  $T_{MAX} = 100^{\circ}$ C,  $T_{MIN} = 0^{\circ}$ C
2. Operation at  $V_{DD} = 5.0$  V guaranteed by design; not production tested.
3. Guaranteed by design; not production tested.

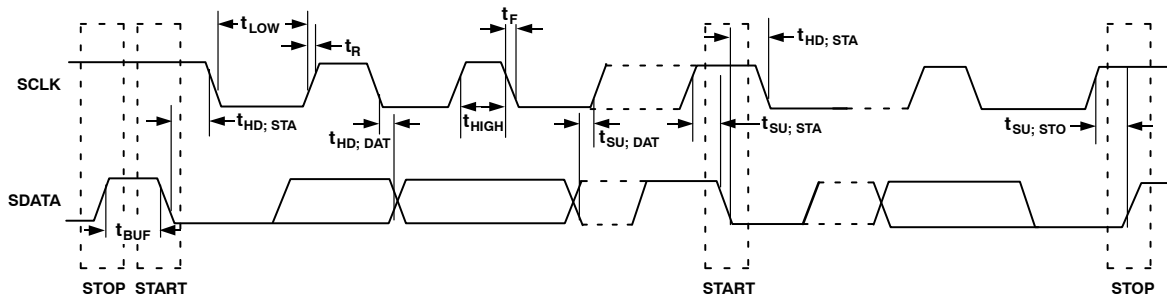

**Figure 2. Serial Bus Timing**

TYPICAL PERFORMANCE CHARACTERISTICS

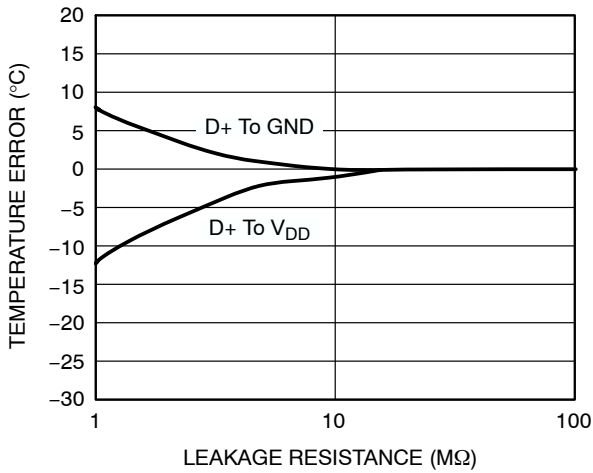

Figure 3. Temperature Error vs. PC Board Track Resistance

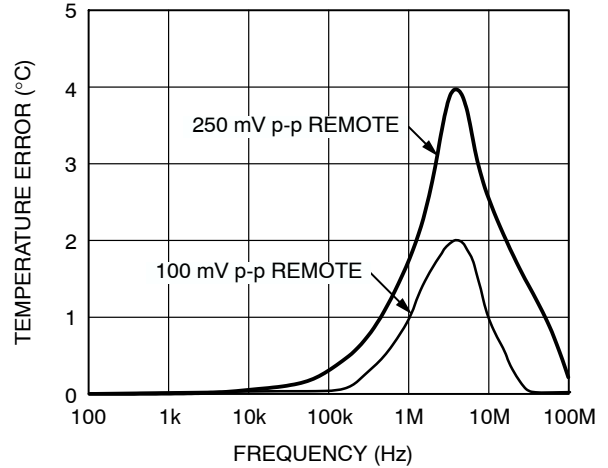

Figure 4. Temperature Error vs. Power Supply Noise Frequency

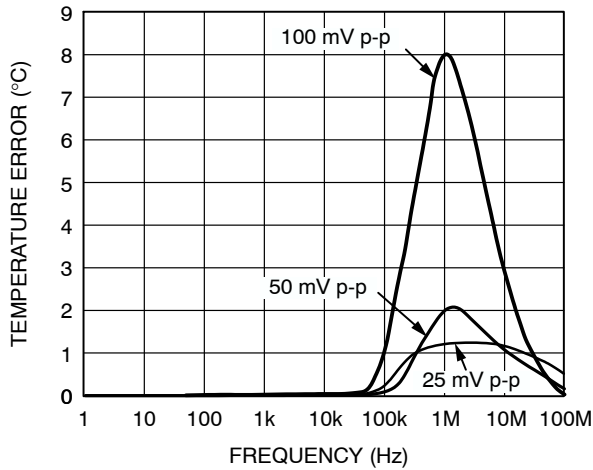

Figure 5. Temperature Error vs. Common-mode Noise Frequency

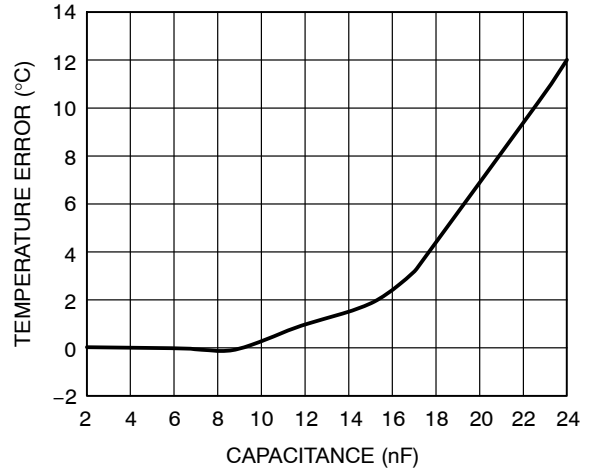

Figure 6. Temperature Error vs. Capacitance between D+ and D-

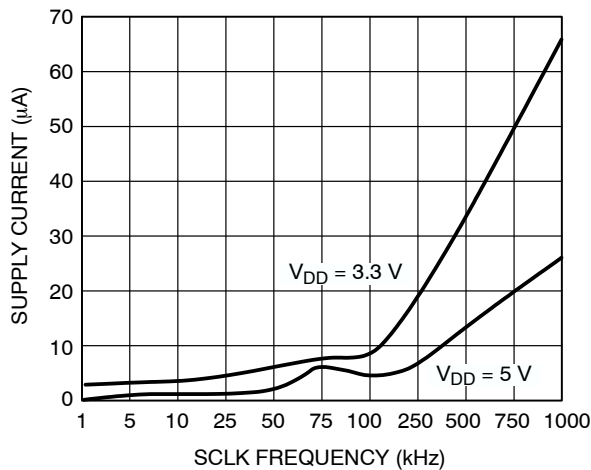

Figure 7. Standby Supply Current vs. Clock Frequency

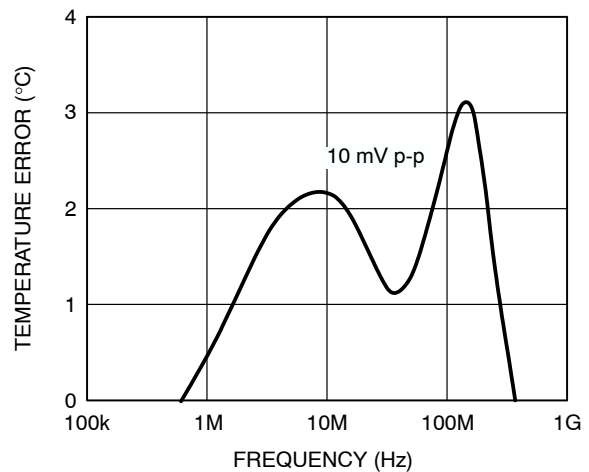

Figure 8. Temperature Error vs. Differential-mode Noise Frequency

# NCT210

## TYPICAL PERFORMANCE CHARACTERISTICS (Cont'd)

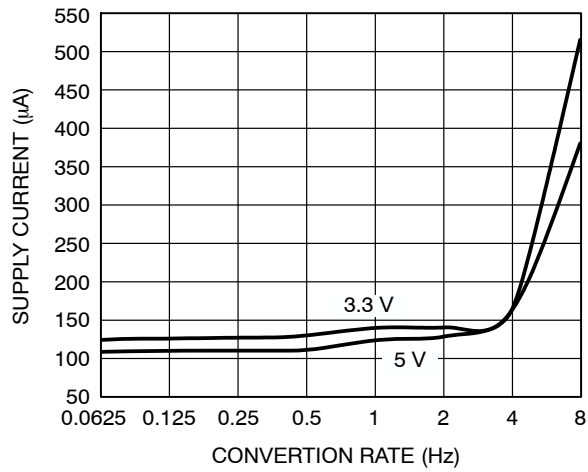

Figure 9. Operating Supply Current vs. Conversion Rate

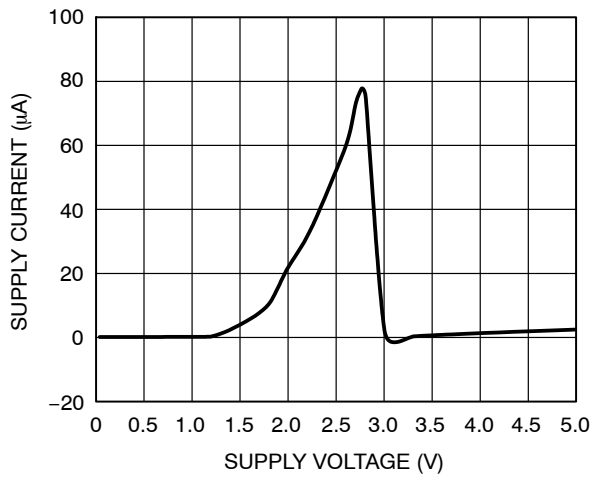

Figure 10. Standby Supply Current vs. Supply Voltage

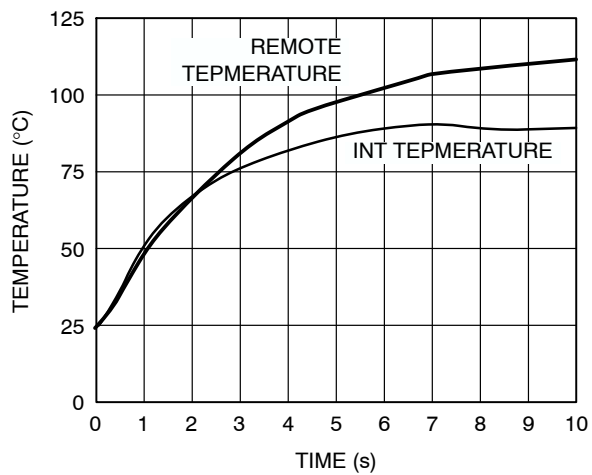

Figure 11. Response to Thermal Shock

**Functional Description**

The NCT210 contains a two-channel A-to-D converter with special input-signal conditioning to enable operation with remote and on-chip diode temperature sensors. When the NCT210 is operating normally, the A-to-D converter operates in free-running mode. The analog input multiplexer alternately selects either the on-chip temperature sensor to measure its local temperature or the remote temperature sensor. These signals are digitized by the ADC and the results stored in the local and remote temperature value registers as 8-bit, two's complement words.

The measurement results are compared with local and remote, high and low temperature limits, stored in four on-chip registers. Out-of-limit comparisons generate flags that are stored in the status register, and one or more out-of-limit results will cause the  $\overline{\text{ALERT}}$  output to pull low.

The limit registers can be programmed and the device controlled and configured via the serial System Management Bus (SMBus). The contents of any register can also be read back via the SMBus.

Control and configuration functions consist of:

- Switching the Device between Normal Operation and Standby Mode
- Masking or Enabling the  $\overline{\text{ALERT}}$  Output
- Selecting the Conversion Rate

On initial powerup, the remote and local temperature values default to  $-128^{\circ}\text{C}$ . Since the device normally powers up converting, a measurement of local and remote temperature is made, and these values are then stored before a comparison with the stored limits is made. However, if the part is powered up in standby mode ( $\overline{\text{STBY}}$  pin pulled low), no new values are written to the register before a comparison is made. As a result, both RLOW and LLOW are tripped in the status register, thus generating an  $\overline{\text{ALERT}}$  output. This can be cleared in one of two ways.

1. Change both the local and remote lower limits to  $-128^{\circ}\text{C}$  and read the status register (which in turn clears the  $\overline{\text{ALERT}}$  output).
2. Take the part out of standby and read the status register (which in turn clears the  $\overline{\text{ALERT}}$  output). This works only if the measured values are within the limit values.

**Measurement Method**

A simple method of measuring temperature is to exploit the negative temperature coefficient of a diode, or the base-emitter voltage of a transistor, operated at constant current. Unfortunately, this technique requires calibration to null the effect of the absolute value of  $V_{\text{BE}}$ , which varies from device to device.

The technique used in the NCT210 is to measure the change in  $V_{\text{BE}}$  when the device is operated at two different currents. This is given by:

$$\Delta V_{\text{BE}} = kT/q \times \ln(N) \quad (\text{eq. 1})$$

where:

k is Boltzmann's constant.

q is the charge on the electron ( $1.6 \times 10^{-19}$  Coulombs).

T is the absolute temperature in Kelvins.

N is the ratio of the two currents.

Figure 12 shows the input signal conditioning used to measure the output of an external temperature sensor.

This figure shows the external sensor as a substrate transistor provided for temperature monitoring on some microprocessors, but it could be a discrete transistor. If a discrete transistor is used, the collector will not be grounded and should be linked to the base. To prevent ground noise interfering with the measurement, the more negative terminal of the sensor is not referenced to ground, but is biased above ground by an internal diode at the D- input. If the sensor is operating in a noisy environment, one can optionally be added as a noise filter. Its value is typically 2,200 pF, but it should be no more than 3,000 pF. See the Layout Considerations section for more information.

To measure  $\Delta V_{\text{BE}}$ , the sensor is switched between operating currents of I and  $N \times I$ . The resulting waveform is passed through a 65 kHz low-pass filter to remove noise, and then to a chopper-stabilized amplifier that performs the functions of amplification and rectification of the waveform to produce a dc voltage proportional to  $\Delta V_{\text{BE}}$ . This voltage is measured by the ADC to give a temperature output in 8-bit, two's complement format. To reduce the effects of noise further, digital filtering is performed by averaging the results of 16 measurement cycles.

Signal conditioning and measurement of the internal temperature sensor is performed in a similar manner.

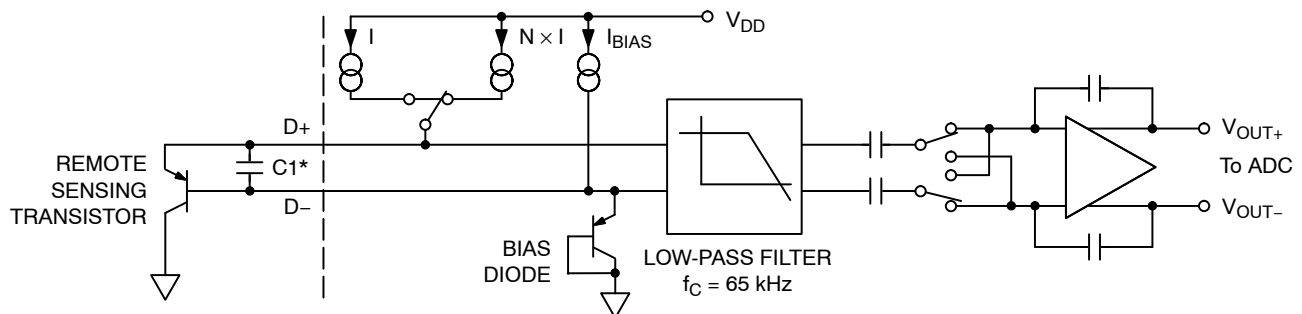

\*CAPACITOR C1 IS OPTIONAL. IT IS ONLY NECESSARY IN NOISY ENVIRONMENTS. C1 = 2.2 nF TYP, 3 nF MAX

**Figure 12. Input Signal Conditioning**



**Temperature Data Format**

One LSB of the ADC corresponds to 1°C so the ADC can theoretically measure from -128°C to +127°C, although the device does not measure temperatures below -65°C; therefore, the actual range is -65°C to 127°C. The temperature data format is shown in Table 5.

The results of the local and remote temperature measurements are stored in the local and remote temperature value registers and are compared with limits programmed into the local and remote high and low limit registers.

**Table 5. TEMPERATURE DATA FORMAT**

Temperature (°C)	Digital Output
-65	1 011 1111
-55	1 100 1001
-25	1 110 0111
0	0 000 0000
1	0 000 0001
10	0 000 1010
25	0 001 1001
50	0 011 0010
75	0 100 1011
100	0 110 0100
125	0 111 1101
127	0 111 1111

**Registers**

The NCT210 contains nine registers that are used to store the results of remote and local temperature measurements, and high and low temperature limits, and to configure and control the device. A description of these registers follows, and further details are given in Table 6 to Table 8. It should be noted that the NCT210's registers are dual port and have different addresses for read and write operations. Attempting to write to a read address, or to read from a write address, produces an invalid result. Register addresses above 0x0F are reserved for future use or used for factory test purposes and should not be written to.

**Address Pointer Register**

The address pointer register does not have and does not require an address, because it is the register to which the first data byte of every write operation is written automatically. This data byte is an address pointer that sets up one of the other registers for the second byte of the write operation or for a subsequent read operation.

**Value Registers**

The NCT210 has two registers to store the results of local and remote temperature measurements. These registers are written to by the ADC and can only be read over the SMBus.

**Status Register**

Bit 7 of the status register indicates when it is high that the ADC is busy converting. Bit 5 to Bit 3 are flags that indicate the results of the limit comparisons.

If the local and/or remote temperature measurement is above the corresponding high temperature limit or below the corresponding low temperature limit, then one or more of these flags are set. Bit 2 is a flag that is set if the remote temperature sensor is open-circuit. These five flags are NOR'd together so that if any of them are high, the  $\overline{\text{ALERT}}$  interrupt latch is set and the  $\overline{\text{ALERT}}$  output goes low. Reading the status register clears the five flag bits, provided the error conditions that caused the flags to be set have gone away. While a limit comparator is tripped due to a value register containing an out-of-limit measurement, or the sensor is open-circuit, the corresponding flag bit cannot be reset. A flag bit can only be reset if the corresponding value register contains an in-limit measurement, or the sensor is good.

**Table 6. STATUS REGISTER BIT ASSIGNMENTS**

Bit	Name	Function
7	BUSY	1 when ADC Converting
6	LHIGH*	1 when Local High Temp Limit Tripped
5	LLOW*	1 when Local Low Temp Limit Tripped
4	RHIGH*	1 when Remote High Temp Limit Tripped
3	RLOW*	1 when Remote Low Temp Limit Tripped
2	OPEN*	1 when Remote Sensor Open-circuit
1 to 0		Reserved

\*These flags stay high until the status register is read or they are reset by POR.

# NCT210

**Table 7. LIST OF NCT210 REGISTERS**

Read Address (Hex)	Write Address (Hex)	Name	Power-On Default
Not Applicable	Not Applicable	Address Pointer	Undefined
00	Not Applicable	Local Temperature Value	1000 0000 (0x80) (-128°C)
01	Not Applicable	Remote Temperature Value	1000 0000 (0x80) (-128°C)
02	Not Applicable	Status	Undefined
03	09	Configuration	0000 0000 (0x00)
04	0A	Conversion Rate	0000 0010 (0x02)
05	0B	Local Temperature High Limit	0111 1111 (0x7F) (+127°C)
06	0C	Local Temperature Low Limit	1100 1001 (0xC9) (-55°C)
07	0D	Remote Temperature High Limit	0111 1111 (0x7F) (+127°C)
08	0E	Remote Temperature Low Limit	1100 1001 (0xC9) (-55°C)
Not Applicable	0F (Note 1)	One-shot	
10	Not Applicable	Reserved	Reserved for Future Versions
12	12	Reserved	Reserved for Future Versions
13	13	Reserved	Reserved for Future Versions
14	14	Reserved	Reserved for Future Versions
15	16	Reserved	Reserved for Future Versions
17	18	Reserved	Reserved for Future Versions
19	Not Applicable	Reserved	Reserved for Future Versions
20	21	Reserved	Reserved for Future Versions
FE	Not Applicable	Manufacturer Device ID	0100 0001 (0x41)
FF	Not Applicable	Die revision Code	0011 xxxx (0x3x)

1. Writing to Address 0F causes the NCT210 to perform a single measurement. It is not a data register and data written to it is irrelevant.

The  $\overline{\text{ALERT}}$  interrupt latch is not reset by reading the status register, but is reset when the  $\overline{\text{ALERT}}$  output is serviced by the master reading the device address, provided the error condition has gone away and the status register flag bits have been reset.

### Configuration Register

Two bits of the configuration register are used. If Bit 6 is 0, which is the power-on default, the device is in operating mode with the ADC converting. If Bit 6 is set to 1, the device is in standby mode and the ADC does not convert. Standby mode can also be selected by taking the  $\overline{\text{STBY}}$  pin low. In standby mode, the values stored in the remote and local temperature registers remain at the values they were when the part was placed in standby.

Bit 7 of the configuration register is used to mask the  $\overline{\text{ALERT}}$  output. If Bit 7 is 0, which is the power-on default, the  $\overline{\text{ALERT}}$  output is enabled. If Bit 7 is set to 1, the  $\overline{\text{ALERT}}$  output is disabled.

**Table 8. CONFIGURATION REGISTER BIT ASSIGNMENTS**

Bit	Name	Function	Power-On Default
7	MASK1	0 = $\overline{\text{ALERT}}$ Enabled 1 = $\overline{\text{ALERT}}$ Masked	0
6	RUN/STOP	0 = Run 1 = Standby	0
5 to 0		Reserved	0

### Conversion Rate Register

The lowest three bits of this register are used to program the conversion rate by dividing the ADC clock by 1, 2, 4, 8, 16, 32, 64, or 128 to give conversion times from 125 ms (Code 0x07) to 16 seconds (Code 0x00). This register can be written to and read back over the SMBus. The higher five bits of this register are unused and must be set to 0. Use of slower conversion times greatly reduces the device power consumption, as shown in Table 9.

**Table 9. CONVERSION RATE REGISTER CODE**

Data	Conversion/ Sec	Average Supply Current $\mu\text{A}$ Typ at $V_{CC} = 3.3\text{ V}$
0x00	0.0625	150
0x01	0.125	150
0x02	0.25	150
0x03	0.5	150
0x04	1	150
0x05	2	150
0x06	4	160
0x07	8	180
0x08 to 0xFF	Reserved	-

**Limit Registers**

The NCT210 has four limit registers to store local and remote and high and low temperature limits. These registers can be written to and read back over the SMBus. The high limit registers perform a > comparison, while the low limit registers perform a < comparison. For example, if the high limit register is programmed as a limit of 80°C, measuring 81°C results in an alarm condition.

**One-shot Register**

The one-shot register is used to initiate a single conversion and comparison cycle when the NCT210 is in standby mode, after which the device returns to standby. This is not a data register as such, and it is the write operation that causes the one-shot conversion. The data written to this address is irrelevant and is not stored.

**Serial Bus Interface**

Control of the NCT210 is carried out via the serial bus. The NCT210 is connected to this bus as a slave device, under the control of a master device. Note that the SMBus and SCL pins are three-stated when the NCT210 is powered down and will not pull down the SMBus.

**Address Pins**

In general, every SMBus device has a 7-bit device address (except for some devices that have extended 10-bit addresses). When the master device sends a device address over the bus, the slave device with that address responds.

The NCT210 has two address pins, ADD0 and ADD1, to allow selection of the device address so that several NCT210's can be used on the same bus, and/or to avoid conflict with other devices. Although only two address pins are provided, these are three-state and can be grounded, left unconnected, or tied to  $V_{DD}$  so that a total of nine different addresses are possible, as shown in Table 10.

It should be noted that the state of the address pins is only sampled at powerup, so changing them after powerup has no effect.

**Table 10. DEVICE ADDRESSES** (Note 1)

ADD0	ADD1	Device Address
0	0	0011 000
0	NC	0011 001
0	1	0011 010
NC	0	0101 001
NC	NC	0101 010
NC	1	0101 011
1	0	1001 100
1	NC	1001 101
1	1	1001 110

1. ADD0 and ADD1 are sampled at powerup only.

The serial bus protocol operates as follows:

1. The master initiates data transfer by establishing a start condition, defined as a high-to-low transition on the serial data line SDATA, while the serial clock line SCLK remains high. This indicates that an address/data stream will follow. All slave peripherals connected to the serial bus respond to the START condition and shift in the next eight bits, consisting of a 7-bit address (MSB first) plus an  $R/\overline{W}$  bit, which determines the direction of the data transfer, that is, whether data will be written to or read from the slave device.  
The peripheral whose address corresponds to the transmitted address responds by pulling the data line low during the low period before the ninth clock pulse, known as the Acknowledge Bit. All other devices on the bus now remain idle while the selected device waits for data to be read from or written to it. If the  $R/\overline{W}$  bit is a 0, the master writes to the slave device. If the  $R/\overline{W}$  bit is a 1, the master reads from the slave device.
2. Data is sent over the serial bus in sequences of nine clock pulses, eight bits of data followed by an Acknowledge Bit from the slave device.  
Transitions on the data line must occur during the low period of the clock signal and remain stable during the high period, because a low-to-high transition when the clock is high can be interpreted as a stop signal. The number of data bytes that can be transmitted over the serial bus in a single read or write operation is limited only by what the master and slave devices can handle.
3. When all data bytes have been read or written, stop conditions are established. In write mode, the master pulls the data line high during the 10th clock pulse to assert a stop condition. In read mode, the master device overrides the acknowledge bit by pulling the data line high during the low period before the ninth clock pulse. This is known as No Acknowledge. The master then takes the data line low during the low period

# NCT210

before the 10th clock pulse, then high during the 10th clock pulse to assert a stop condition.

Any number of bytes of data can be transferred over the serial bus in one operation, but it is not possible to mix read and write in one operation, because the type of operation is determined at the beginning and cannot subsequently be changed without starting a new operation.

For the NCT210, write operations contain either one or two bytes, while read operations contain one byte.

To write data to one of the device data registers or read data from it, the address pointer register must be set so that the correct data register is addressed, data can then be written

into that register or read from it. The first byte of a write operation always contains a valid address that is stored in the address pointer register. If data is to be written to the device, the write operation contains a second data byte that is written to the register selected by the address pointer register.

This is illustrated in Figure 13. The device address is sent over the bus followed by  $R/\overline{W}$  set to 0. This is followed by two data bytes. The first data byte is the address of the internal data register to be written to, which is stored in the address pointer register. The second data byte is the data to be written to the internal data register.

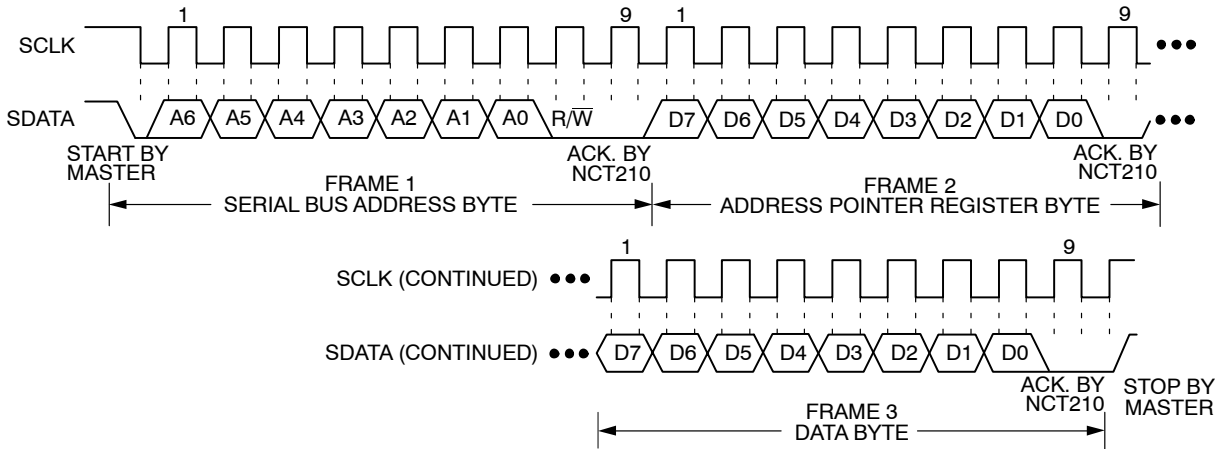

**Figure 13. Writing a Register Address to the Address Pointer Register, then Writing Data to the Selected Register**

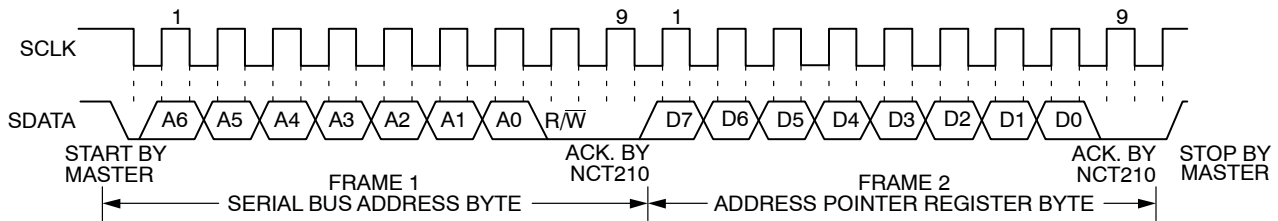

**Figure 14. Writing to the Address Pointer Register Only**

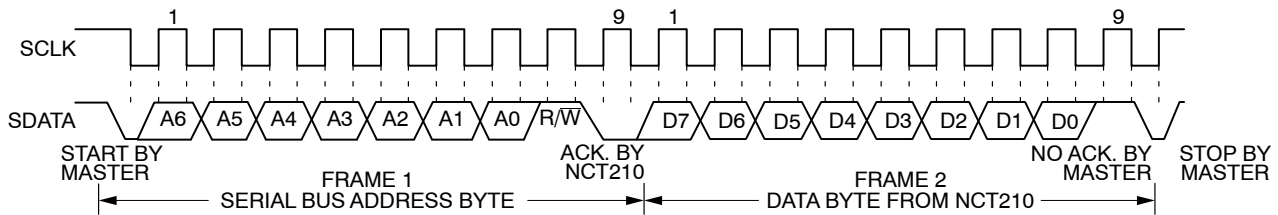

**Figure 15. Reading Data from a Previously Selected Register**

When reading data from a register there are two possibilities:

1. If the NCT210's address pointer register value is unknown or not the desired value, it is first necessary to set it to the correct value before data can be read from the desired data register. This is done by performing a write to the NCT210 as

before, but only the data byte containing the register read address is sent, because data is not to be written to the register. This is shown in Figure 14.

A read operation is then performed consisting of the serial bus address,  $R/\overline{W}$  bit set to 1, followed

by the data byte read from the data register. This is shown in Figure 15.

2. If the address pointer register is known to be already at the desired address, data can be read from the corresponding data register without first writing to the address pointer register, so Figure 14 can be omitted.

NOTES: Although it is possible to read a data byte from a data register without first writing to the address pointer register, if the address pointer register is already at the correct value, it is not possible to write data to a register without writing to the address pointer register; this is because the first data byte of a write is always written to the address pointer register.

Remember that the NCT210 registers have different addresses for read and write operations. The write address of a register must be written to the address pointer if data is to be written to that register, but it is not possible to read data from that address. The read address of a register must be written to the address pointer before data can be read from that register.

### ALERT Output

The  $\overline{\text{ALERT}}$  output goes low whenever an out-of-limit measurement is detected, or if the remote temperature sensor is open-circuit. It is an open drain and requires a 10 k $\Omega$  pullup to  $V_{\text{DD}}$ . Several  $\overline{\text{ALERT}}$  outputs can be wire-ANDed together so the common line goes low if one or more of the  $\overline{\text{ALERT}}$  outputs goes low.

The  $\overline{\text{ALERT}}$  output can be used as an interrupt signal to a processor, or it can be used as an  $\overline{\text{SMBALERT}}$ . Slave devices on the SMBus cannot normally signal to the master that they want to talk, but the  $\overline{\text{SMBALERT}}$  function allows them to do so.

One or more  $\overline{\text{ALERT}}$  outputs are connected to a common  $\overline{\text{SMBALERT}}$  line connected to the master. When the  $\overline{\text{SMBALERT}}$  line is pulled low by one of the devices, the following procedure occurs, as shown in Figure 16.

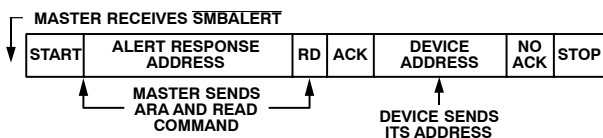

Figure 16. Use of  $\overline{\text{SMBALERT}}$

1.  $\overline{\text{SMBALERT}}$  is pulled low.
2. Master initiates a read operation and sends the alert response address (ARA = 0001 100). This is a general call address that must not be used as a specific device address.
3. The device whose  $\overline{\text{ALERT}}$  output is low responds to the alert response address and the master reads its device address. The address of the device is now known and it can be interrogated in the usual way.
4. If more than one device's  $\overline{\text{ALERT}}$  output is low, the one with the lowest device address has priority, in accordance with normal SMBus arbitration.

5. Once the NCT210 has responded to the alert response address, it resets its  $\overline{\text{ALERT}}$  output, provided that the error condition that caused the  $\overline{\text{ALERT}}$  no longer exists. If the  $\overline{\text{SMBALERT}}$  line remains low, the master sends the ARA again, and so on until all devices whose  $\overline{\text{ALERT}}$  outputs were low have responded.

### Low Power Standby Modes

The NCT210 can be put into a low power standby mode using hardware or software, that is, by taking the  $\overline{\text{STBY}}$  input low, or by setting Bit 6 of the configuration register. When  $\overline{\text{STBY}}$  is high or Bit 6 is low, the NCT210 operates normally. When  $\overline{\text{STBY}}$  is pulled low or Bit 6 is high, the ADC is inhibited, so any conversion in progress is terminated without writing the result to the corresponding value register.

The SMBus is still enabled. Power consumption in the standby mode is reduced to less than 10  $\mu\text{A}$  if there is no SMBus activity or 100  $\mu\text{A}$  if there are clock and data signals on the bus.

These two modes are similar but not identical. When  $\overline{\text{STBY}}$  is low, conversions are completely inhibited. When Bit 6 is set but  $\overline{\text{STBY}}$  is high, a one-shot conversion of both channels can be initiated by writing 0xXX to the one-shot register (Address 0x0F).

### Sensor Fault Detection

The NCT210 has a fault detector at the D+ input that detects if the external sensor diode is open-circuit. This is a simple voltage comparator that trips if the voltage at D+ exceeds  $V_{\text{CC}} - 1.0 \text{ V}$  (typical). The output of this comparator is checked when a conversion is initiated and sets Bit 2 of the status register if a fault is detected.

In this respect, the NCT210 differs from and improves upon competitive devices that output 0 if the external sensor goes short-circuit. These devices can misinterpret a genuine 0°C measurement as a fault condition.

If the external diode channel is not being used and is shorted out, the resulting  $\overline{\text{ALERT}}$  can be cleared by writing 0x80 (-128°C) to the low limit register.

### Factors Affecting Accuracy

#### Remote Sensing Diode

The NCT210 is designed to work with substrate transistors built into processors, or with discrete transistors. Substrate transistors are generally PNP types with the collector connected to the substrate. Discrete types can be either PNP or NPN, connected as a diode (base shorted to collector). If an NPN transistor is used, the collector and base are connected to D+ and the emitter to D-. If a PNP transistor is used, the collector and base are connected to D- and the emitter to D+.

The user has no choice in the case of substrate transistors, but if a discrete transistor is used, the best accuracy is

obtained by choosing devices according to the following criteria:

1. Base-emitter voltage greater than 0.25 V at 6  $\mu$ A, at the highest operating temperature.
2. Base-emitter voltage less than 0.95 V at 100  $\mu$ A, at the lowest operating temperature.
3. Base resistance less than 100  $\Omega$ .
4. Small variation in  $h_{FE}$  (such as 50 to 150), which indicates tight control of  $V_{BE}$  characteristics.

Transistors, such as 2N3904, 2N3906, or equivalents, in SOT-23 package are suitable devices to use.

**Thermal Inertia and Self-heating**

Accuracy depends on the temperature of the remote-sensing diode and/or the internal temperature sensor being at the same temperature as that being measured, and a number of factors can affect this. Ideally, the sensor should be in good thermal contact with the part of the system being measured, for example the processor. If it is not, the thermal inertia caused by the mass of the sensor causes a lag in the response of the sensor to a temperature change. For the remote sensor, this should not be a problem, because it is either a substrate transistor in the processor or a small package device, such as SOT-23, placed in close proximity to it.

The on-chip sensor is, however, often remote from the processor and only monitors the general ambient temperature around the package. The thermal time constant of the QSOP-16 package is approximately 10 seconds.

In practice, the package will have an electrical, and hence a thermal, connection to the printed circuit board, so the temperature rise due to self-heating is negligible.

**Layout Considerations**

Digital boards can be electrically noisy environments, and because the NCT210 is measuring very small voltages from the remote sensor, care must be taken to minimize noise induced at the sensor inputs. The following precautions should be taken:

1. Place the NCT210 as close as possible to the remote sensing diode. Provided that the worst noise sources, such as clock generators, data/address buses, and CRTs, are avoided, this distance can be four to eight inches.
2. Route the D+ and D- tracks close together, in parallel, with grounded guard tracks on each side. Provide a ground plane under the tracks, if possible.
3. Use wide tracks to minimize inductance and reduce noise pickup. 10 mil track minimum width and spacing is recommended.

4. Try to minimize the number of copper/solder joints, which can cause thermocouple effects. Where copper/solder joints are used, ensure they are in both the D+ and D- paths and at the same temperature. Thermocouple effects should not be a major problem as 1°C corresponds to about 240  $\mu$ V, and thermocouple voltages are about 3  $\mu$ V/°C of temperature difference. Unless there are two thermocouples with a big temperature differential between them, thermocouple voltages should be much less than 240  $\mu$ V.
5. Place a 0.1  $\mu$ F bypass capacitor close to the  $V_{DD}$  pin, and 2,200 pF input filter capacitors across D+, D- close to the NCT210.
6. If the distance to the remote sensor is more than eight inches, the use of twisted pair cable is recommended. This works up to about 6 to 12 feet.
7. For very long distances (up to 100 feet), use shielded twisted pair, such as Belden #8451 microphone cable. Connect the twisted pair to D+ and D- and the shield to GND close to the NCT210. Leave the remote end of the shield unconnected to avoid ground loops.



**Figure 17. Arrangement of Signal Tracks**

Because the measurement technique uses switched current sources, excessive cable and/or filter capacitance can affect the measurement. When using long cables, the filter capacitor can be reduced or removed. Cable resistance can also introduce errors. A series resistance of 1  $\Omega$  introduces about 1°C error.

**Application Circuits**

Figure 18 shows a typical application circuit for the NCT210, using a discrete sensor transistor connected via a shielded, twisted pair cable. The pullups on SCLK, SDATA, and  $\overline{ALERT}$  are required only if they are not already provided elsewhere in the system.

The SCLK and SDATA pins of the NCT210 can be interfaced directly to the SMBus of an I/O chip. Figure 19 shows how the NCT210 might be integrated into a system using this type of I/O controller.

# NCT210

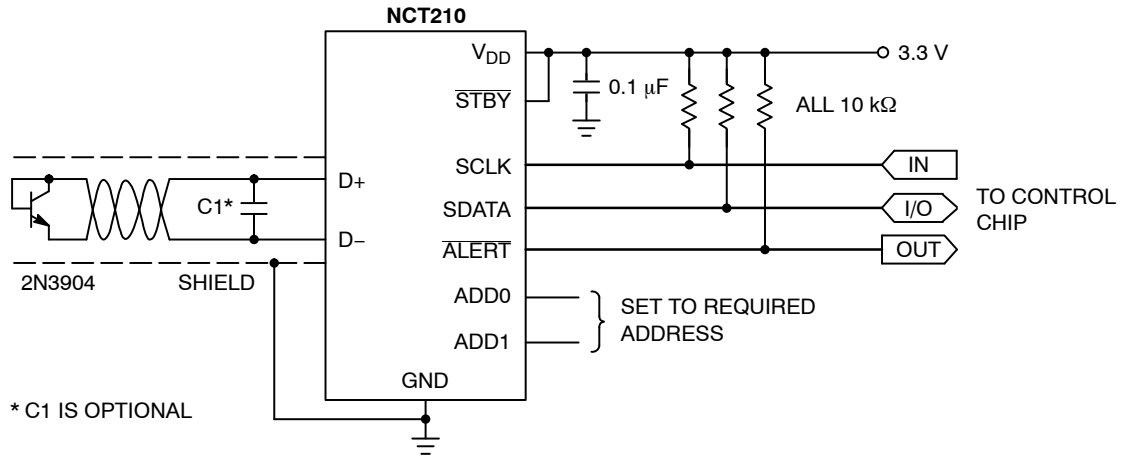

Figure 18. Typical Application Circuit

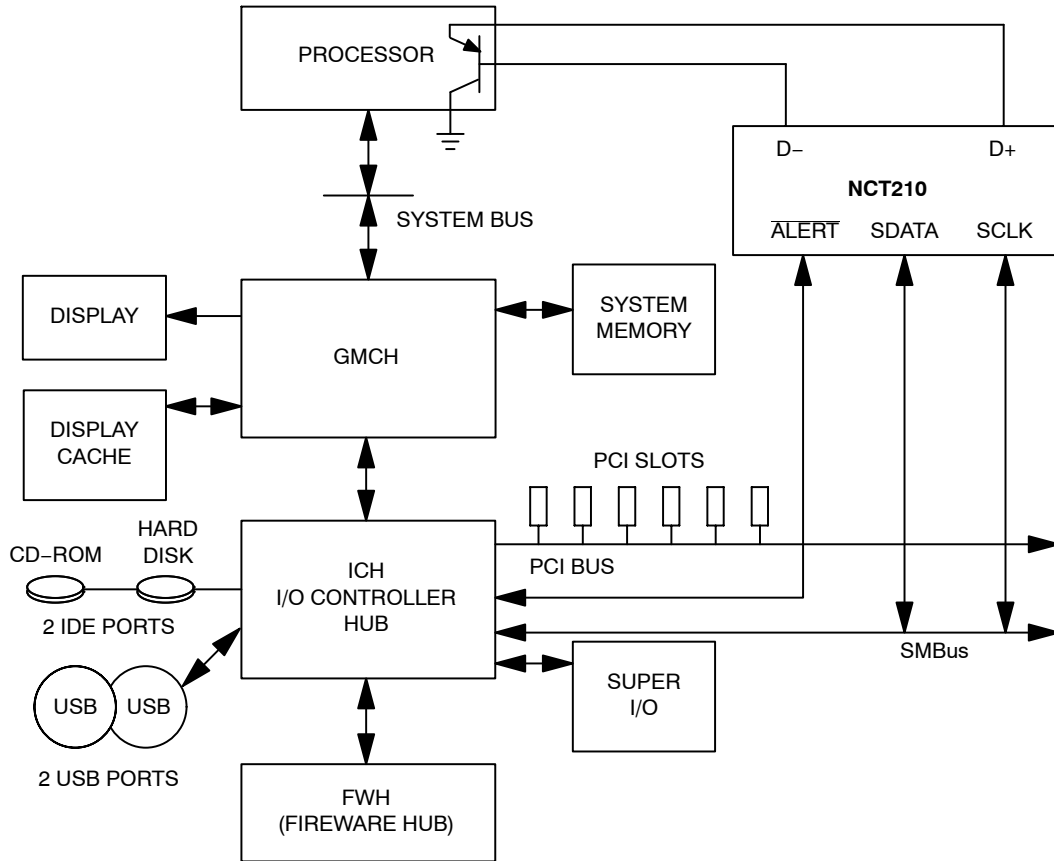

Figure 19. Typical System Using NCT210

Table 11. ORDERING INFORMATION

Device Number	Package Type	Package Option	Shipping†
NCT210RQR2G	16-lead QSOP	RQ	2,500 Tape & Reel

†For information on tape and reel specifications, including part orientation and tape sizes, please refer to our Tape and Reel Packaging Specifications Brochure, BRD8011/D.

# NCT210

## PACKAGE DIMENSIONS

QSOP16  
CASE 492  
ISSUE A

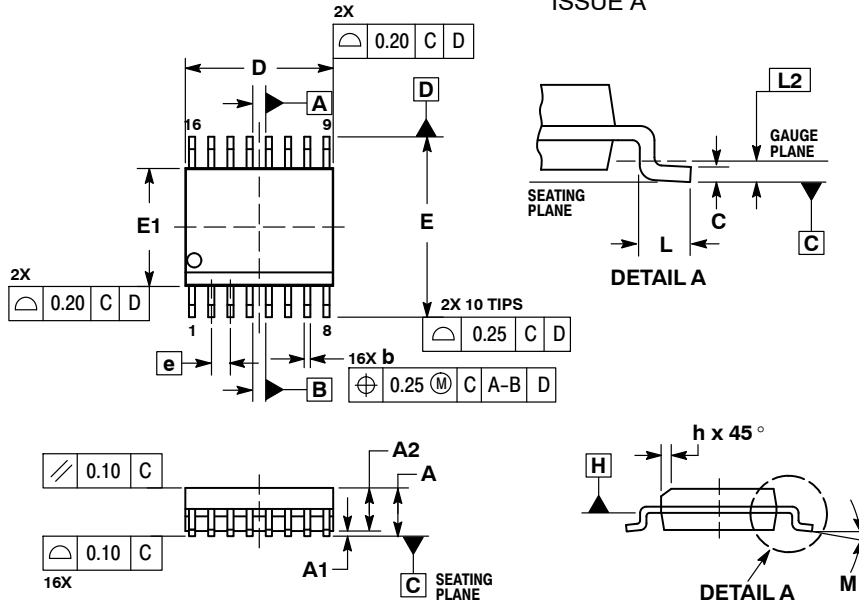

- NOTES:
1. DIMENSIONING AND TOLERANCING PER ASME Y14.5M, 1994.
  2. CONTROLLING DIMENSION: MILLIMETERS.
  3. DIMENSION b DOES NOT INCLUDE DAMBAR PROTRUSION.
  4. DIMENSION D DOES NOT INCLUDE MOLD FLASH, PROTRUSIONS, OR GATE BURRS. MOLD FLASH, PROTRUSIONS, OR GATE BURRS SHALL NOT EXCEED 0.005 PER SIDE. DIMENSION E1 DOES NOT INCLUDE INTERLEAD FLASH OR PROTRUSION. INTERLEAD FLASH OR PROTRUSION SHALL NOT EXCEED 0.005 PER SIDE. D AND E1 ARE DETERMINED AT DATUM H.
  5. DATUMS A AND B ARE DETERMINED AT DATUM H.

DIM	INCHES		MILLIMETERS	
	MIN	MAX	MIN	MAX
A	0.053	0.069	1.35	1.75
A1	0.004	0.010	0.10	0.25
A2	0.049	----	1.24	----
b	0.008	0.012	0.20	0.30
c	0.007	0.010	0.19	0.25
D	0.193 BSC		4.89 BSC	
E	0.237 BSC		6.00 BSC	
E1	0.154 BSC		3.90 BSC	
e	0.025 BSC		0.635 BSC	
h	0.009	0.020	0.22	0.50
L	0.016	0.050	0.40	1.27
L2	0.010 BSC		0.25 BSC	
M	0°	8°	0°	8°

### SOLDERING FOOTPRINT\*

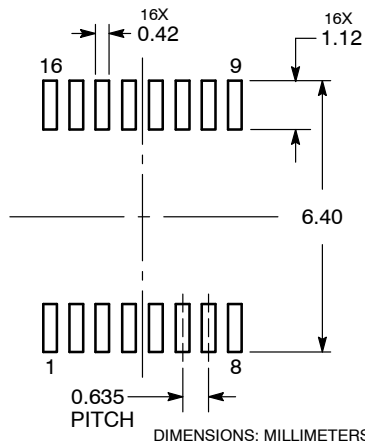

\*For additional information on our Pb-Free strategy and soldering details, please download the ON Semiconductor Soldering and Mounting Techniques Reference Manual, SOLDERRM/D.

ON Semiconductor and are registered trademarks of Semiconductor Components Industries, LLC (SCILLC). SCILLC owns the rights to a number of patents, trademarks, copyrights, trade secrets, and other intellectual property. A listing of SCILLC's product/patent coverage may be accessed at [www.onsemi.com/site/pdf/Patent-Marking.pdf](http://www.onsemi.com/site/pdf/Patent-Marking.pdf). SCILLC reserves the right to make changes without further notice to any products herein. SCILLC makes no warranty, representation or guarantee regarding the suitability of its products for any particular purpose, nor does SCILLC assume any liability arising out of the application or use of any product or circuit, and specifically disclaims any and all liability, including without limitation special, consequential or incidental damages. "Typical" parameters which may be provided in SCILLC data sheets and/or specifications can and do vary in different applications and actual performance may vary over time. All operating parameters, including "Typicals" must be validated for each customer application by customer's technical experts. SCILLC does not convey any license under its patent rights nor the rights of others. SCILLC products are not designed, intended, or authorized for use as components in systems intended for surgical implant into the body, or other applications intended to support or sustain life, or for any other application in which the failure of the SCILLC product could create a situation where personal injury or death may occur. Should Buyer purchase or use SCILLC products for any such unintended or unauthorized application, Buyer shall indemnify and hold SCILLC and its officers, employees, subsidiaries, affiliates, and distributors harmless against all claims, costs, damages, and expenses, and reasonable attorney fees arising out of, directly or indirectly, any claim of personal injury or death associated with such unintended or unauthorized use, even if such claim alleges that SCILLC was negligent regarding the design or manufacture of the part. SCILLC is an Equal Opportunity/Affirmative Action Employer. This literature is subject to all applicable copyright laws and is not for resale in any manner.

### PUBLICATION ORDERING INFORMATION

**LITERATURE FULFILLMENT:**  
Literature Distribution Center for ON Semiconductor  
P.O. Box 5163, Denver, Colorado 80217 USA  
**Phone:** 303-675-2175 or 800-344-3860 Toll Free USA/Canada  
**Fax:** 303-675-2176 or 800-344-3867 Toll Free USA/Canada  
**Email:** [orderlit@onsemi.com](mailto:orderlit@onsemi.com)

**N. American Technical Support:** 800-282-9855 Toll Free  
USA/Canada  
**Europe, Middle East and Africa Technical Support:**  
Phone: 421 33 790 2910  
**Japan Customer Focus Center**  
Phone: 81-3-5817-1050

**ON Semiconductor Website:** [www.onsemi.com](http://www.onsemi.com)  
**Order Literature:** <http://www.onsemi.com/orderlit>  
For additional information, please contact your local Sales Representative