



Chipsmall Limited consists of a professional team with an average of over 10 year of expertise in the distribution of electronic components. Based in Hongkong, we have already established firm and mutual-benefit business relationships with customers from,Europe,America and south Asia,supplying obsolete and hard-to-find components to meet their specific needs.

With the principle of "Quality Parts,Customers Priority,Honest Operation,and Considerate Service",our business mainly focus on the distribution of electronic components. Line cards we deal with include Microchip,ALPS,ROHM,Xilinx,Pulse,ON,Everlight and Freescale. Main products comprise IC,Modules,Potentiometer,IC Socket,Relay,Connector.Our parts cover such applications as commercial,industrial, and automotives areas.

We are looking forward to setting up business relationship with you and hope to provide you with the best service and solution. Let us make a better world for our industry!



Contact us

Tel: +86-755-8981 8866 Fax: +86-755-8427 6832

Email & Skype: info@chipsmall.com Web: www.chipsmall.com

Address: A1208, Overseas Decoration Building, #122 Zhenhua RD., Futian, Shenzhen, China



NCT7717U

Nuvoton

Thermal Sensor IC

Date: Jan./11/2011 Revision: 1.11

NCT7717U Datasheet Revision History

	PAGES	DATES	VERSION	MAIN CONTENTS
1		05/25/09	0.2	Preliminary version.
2		10/29/09	0.3	The ALERT# point hardware power-on setting table and register detail is TBD.
3		12/25/09	0.4	Modified the registers default value and the hardware strapping resistor value.
4		05/06/10	0.5	Modified the hardware strapping resistor value.
5		09/15/10	1.0	Add the top marking specification, key specification and AC/DC specification All versions before 1.0 are preliminary versions
6		12/23/10	1.1	Add taping specification
7	9	1/11/11	1.11	Modified the Alert mod setting register description, correct some typo

Table of Content-

1.	GENERAL DESCRIPTION	1
2.	FEATURES	1
2.1	Monitoring Items - Temperature	1
2.2	General	1
2.3	Package	1
3.	KEY SPECIFICATIONS	1
4.	PIN CONFIGURATION	2
5.	PIN DESCRIPTION.....	2
6.	FUNCTION DESCRIPTION	3
6.1	General Description	3
6.2	Access Interface	3
6.2.1	Data write to the internal register	3
6.2.2	Data read from the internal register	3
6.3	Address Setting	3
6.4	Temperature Measurement Data Format.....	4
6.5	ALERT# Output.....	4
6.5.1	ALERT# Output Comparator Mode	4
6.5.2	ALERT# Output Interrupt Mode	5
6.5.3	ALERT# Output SMBus™ alert Mode	5
6.6	ALERT# point hardware power-on setting	6
7.	REGISTER SUMMARY	6
7.1	Register Map	6
7.2	Register Detail	7
7.2.1	Register : Local Diode Temperature Readout.....	7
7.2.2	Register : Alert Status	7
7.2.3	Register : Configuration	7
7.2.4	Register : Conversion Rate.....	8
7.2.5	Register : Local Diode Temperature Alert Temperature	9
7.2.6	Register : One Shot Conversion	9
7.2.7	Register : Customer Data Log Registers	9
7.2.8	Register : Alert Mode Setting	9
7.2.9	Register : Chip ID	10
7.2.10	Register : Vendor ID	10
7.2.11	Register : Device ID.....	10
8.	ELECTRICAL CHARACTERISTICS	11
8.1	Absolute Maximum Ratings.....	11
8.2	DC Characteristics	11

8.3	AC Characteristics.....	12
9.	ORDER INSTRUCTION.....	13
10.	TOP MARKING SPECIFICATION	13
11.	TAPING SPECIFICATION	13
12.	PACKAGE DRAWING AND DIMENSIONS.....	14

新唐科技 NUVOTON
INTELLECTUAL PROPERTY

新唐科技 NUVOTON
INTELLECTUAL PROPERTY

1. GENERAL DESCRIPTION

NCT7717U is an one on-chip local thermal sensor with high accuracy, a 8-bit ADC (Analog-to-Digital Converter) is built inside NCT7717U to convert the monitored temperature value with 1°C resolution. The NCT7717U supports an independent over temperature protection signal to activate system protection and hardware thermal shutdown via the ALERT# pin.

The NCT7717U is a high precision, low-power consumption IC supporting SMBus™ interface, which is specifically designed for the PC, Notebook applications, and any embedded environments. Its available package is 5-pin SOT23, with the working voltage of 3.3V.

2. FEATURES

2.1 Monitoring Items - Temperature

- One on-chip thermal sensor
- Measure temperature with high accuracy
- Two's complement data format, 1°C resolution

2.2 General

- Alert point supports Hardware Power-on Setting
- I²C® Compatible System Management bus (SMBus™)
- 3.3V±5% V_{DD} operation

2.3 Package

- SOT-23-5 Lead Free (ROHS Compliant) and Halogen Free Package

3. KEY SPECIFICATIONS

PARAMETER	RATING
Local temperature range and accuracy	-40°C to +125°C (TA)
	Typ. ± 2°C (20°C~40°C)
	Max. ± 3°C (-40°C~125°C) *1
Supply voltage	3.3V ± 5%
Operating supply current	700 uA typ.
ADC resolution include sign bit	8 Bits

*1 Guaranteed by design from -40~125 degreeC.

4. PIN CONFIGURATION

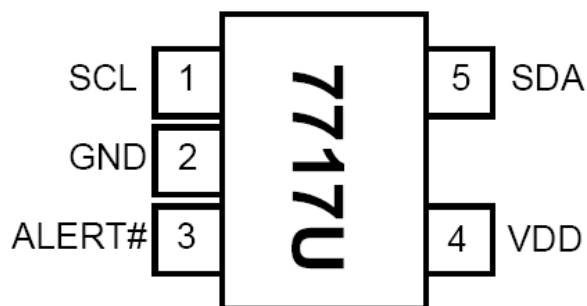

5. PIN DESCRIPTION

PIN TYPE	PIN ATTRIBUTE
OD ₁₂	Open-drain output pin with 12 mA sink capability
IN _{ts}	TTL level input pin and schmitt trigger
P	Power or Ground Pin

PIN NO.	PIN NAME	I/O	FUNCTION
1	SCL	IN _{ts}	SMBus™ Clock
2	GND	P	Power supply ground
3	ALERT#	OD ₁₂	Alarm output, for interrupt control or shutdown control
4	VDD	P	DC Power supply, Voltage input 3.3V±10%
5	SDA	IN _{ts} / OD ₁₂	SMBus™ bi-directional data

6. FUNCTION DESCRIPTION

6.1 General Description

NCT7717U is SMBus™ interface device to provide on-die temperature sensor, 1 wire alert signal for event notification or system shutdown.

6.2 Access Interface

NCT7717U provides SMBus™ to access the internal register, supports SMBus™ byte write and byte read protocols.

6.2.1 Data write to the internal register

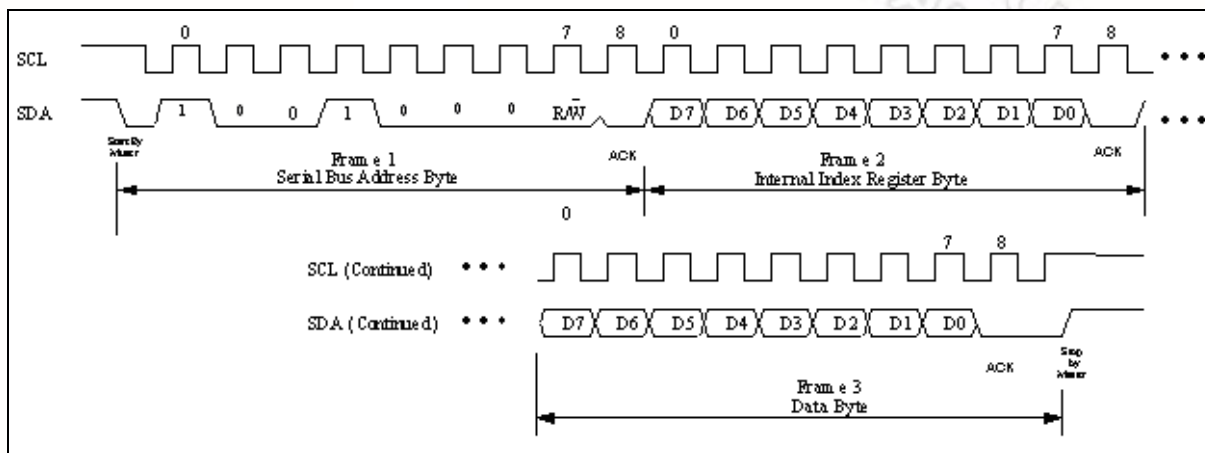

6.2.2 Data read from the internal register

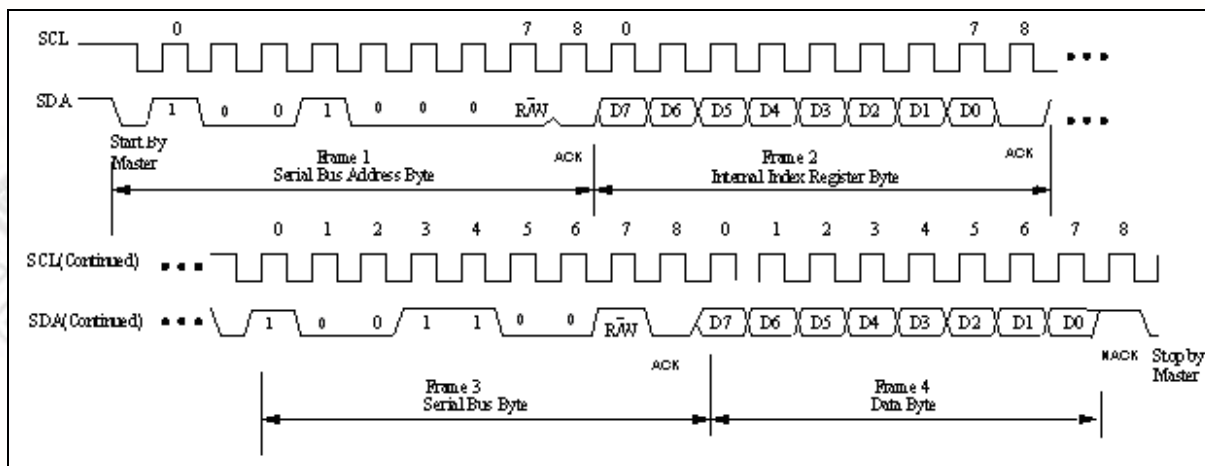

6.3 Address Setting

NCT7717U I²C/ SMBus™ address is 1001000xb (x is R/W bit).

6.4 Temperature Measurement Data Format

The local temperature (on-die) data with 8-bit 2's complement format.

TEMPERATURE	8-BIT DIGITAL OUTPUT
+127°C	0111,1111
+25°C	0001,1001
+2°C	0000,0010
+1°C	0000,0001
+0°C	0000,0000
- 1°C	1111,1111
- 2°C	1111,1110
- 25°C	1110,0111
- 128°C	1000,0000

6.5 ALERT# Output

The NCT7717U ALERT# pin is an active-low open-drain output pin which is triggered when measured temperature exceeds the limitation defined in the limit registers. There are three types of ALERT# output mode: the ALERT# output comparator mode, the ALERT# output interrupt mode, and the ALERT# output SMBus™ ALERT# mode.

6.5.1 ALERT# Output Comparator Mode

Figure 1 shows the mechanism of the ALERT# output comparator mode. In this mode, the ALERT# pin will be alerted if the monitored temperature is out-of-limit and the ALERT# pin keeps low until the temperature goes back to the target range.

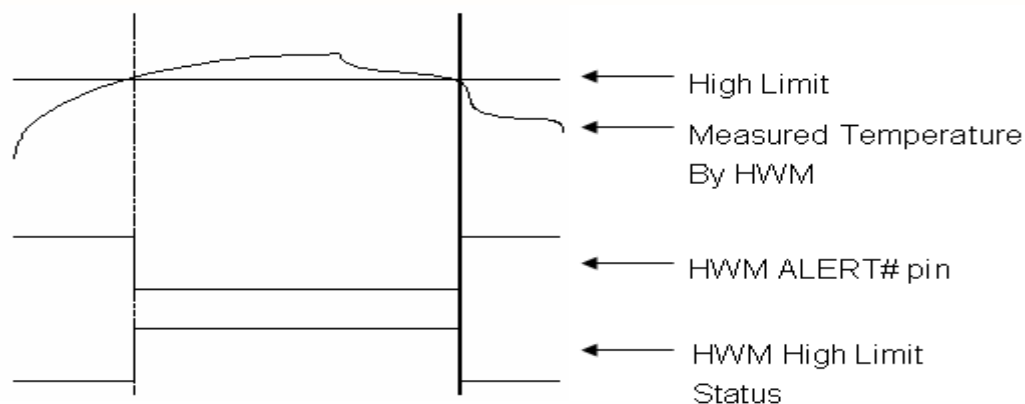

Figure 1

6.5.2 ALERT# Output Interrupt Mode

Figure 2 shows the mechanism of the ALERT# output interrupt mode. In this mode, the NCT7717U will set the ALERT mask bit of Configuration Register during a read of the Status Register if any flag in Status Register, except the ADC_Busy flag is set. This prevents further ALERT# triggering until the master has reset the ALERT mask bit (write 0 to Alert_MSK), at the end of the interrupt service routine. The Status Register flags are cleared only upon a read Status Register command from the master and will be re-alerted at the end of the next temperature conversion if the measured temperature still falls outside of the allowed range.

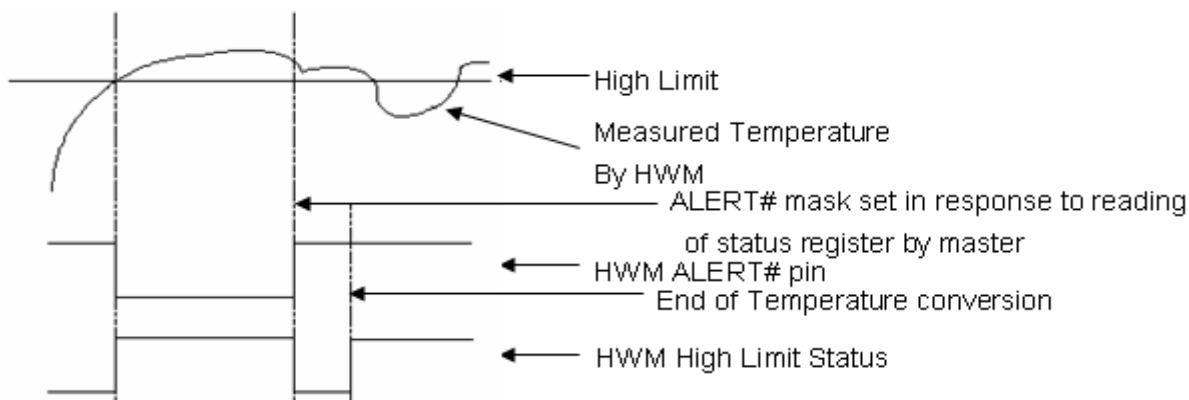

Figure 2

6.5.3 ALERT# Output SMBus™ alert Mode

Figure 3 shows the mechanism of the ALERT# output SMBus™ alert mode. In this mode, the ALERT# output of the NCT7717U is connected to the SMBus™ alert line which has more than one device connected to it. Through such an implementation, SMBus™ alert mode can assist the master in resolving which slave generates an interrupt. When the measured temperature falls outside of the allowed range, the ALERT# pin will be pulled low and the corresponding alert flags in Status Register will be set to 1. The ALERT mask bit will just be set if there is a read command for Status Register or when SMBus™ ALERT Response Address (ARA) occurs from master (Alert Response Address is 0001100x). Meanwhile, the NCT7717U will generate and return its own address to the master. If the temperature never falls outside of the allowed range, the latched ALERT# pin can release by the reset ALERT mask bit and the latched corresponding alert flags in Status Register can release by reading command for Status Register.

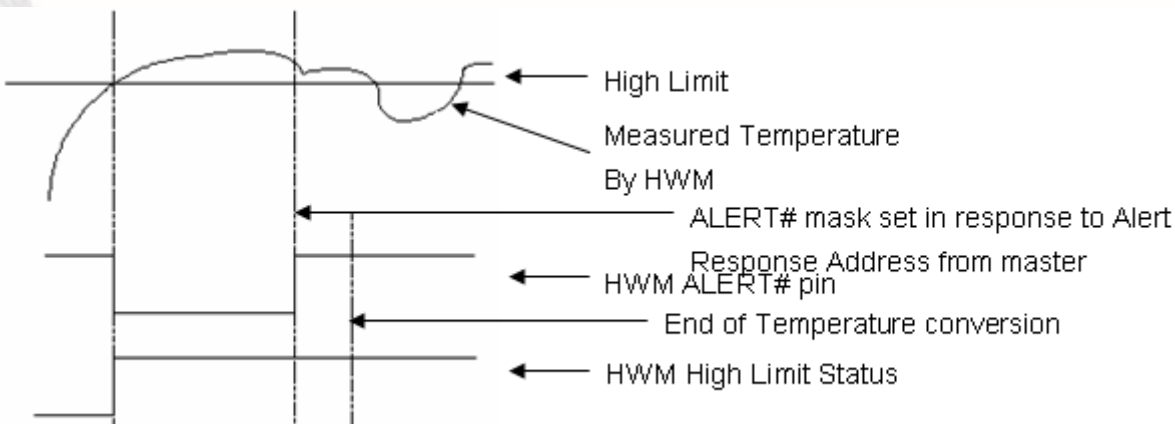

Figure 3

6.6 ALERT# point hardware power-on setting

The default value could be set after power up 100ms by different pull-up resistor of ALERT# pin:

PULL-UP RESISTOR		TEMPERATURE (°C)
ALERT	2KΩ	75
	7.5KΩ	90
	10.5KΩ	100
	14KΩ	105
	18.7KΩ	110

7. REGISTER SUMMARY

7.1 Register Map

Idx	Register Name	Attr	Dft	7	6	5	4	3	2	1	0
0	LDT Readout	RO	00	MNTREG_LT[7:0]							
2	Alert Status	RO	00	ADC_Busy	STS_LTHA	Reserved					
3	Configuration [R]	RW	21	ALERT_MSK	STOP_Mnt	Reserved				EN_FaultQueue	
4	Conversion Rate [R]	RW	08	Reserved				ConvRate[3:0]			
5	LT High Alert Temp [R]	RW	-	LT_HAT[7:0]							
9	Configuration [W]	RW	21	ALERT_MSK	STOP_Mnt	Reserved				EN_FaultQueue	
A	Conversion Rate [W]	RW	08	Reserved				ConvRate[3:0]			
B	LT High Alert Temp [W]	RW	-	LT_HAT[7:0]							
F	One Shot Conversion	WO	FF								
2D	Customer Data Log Register 1	RW	00	CustomerLogReg1[7:0]							
2E	Customer Data Log Register 2	RW	00	CustomerLogReg2[7:0]							
2F	Customer Data Log Register 3	RW	00	CustomerLogReg3[7:0]							
BF	Alert mode	RW	01	Reserved							Alert_MD
FD	CID (Chip ID)	RO	50	50h							
FE	VID (Vendor ID)	RO	50	50h							
FF	DID (Device ID)	RO	90	90H							

7.2 Register Detail

7.2.1 Register : Local Diode Temperature Readout

Location : Address 00h

Type : Read Only

Power on default value : 00

BIT	7	6	5	4	3	2	1	0
NAME	Local Diode Temperature Readout Value. The real temperature value calculation is referred to TEMPERATURE MEASUREMENT DATA FORMAT.							
VALUE	SIGN	64	32	16	8	4	2	1

7.2.2 Register : Alert Status

Location : Address 02h

Type : Read Only

Power on default value : 00

BIT	7	6	5	4	3	2	1	0
NAME	ADC_Busy	STS_LTHA	Reserved					
DEFAULT	0	0						

BIT	FLAG NAME	DESCRIPTION
7	ADC_Busy	If set to '1' indicates ADC is busy converting.
6	STS_LTHA	If set to '1' indicates a measured Local Diode Temperature Higher than Local High set point (High Limit).

7.2.3 Register : Configuration

Location : Read = Address 03h Write = Address 09h

Type : Read/Write

Power on default value : 21

BIT	7	6	5	4	3	2	1	0
NAME	ALERT_MSK	STOP_Mnt	Reserved				EN_FaultQueue	
DEFAULT	0	0					1	

BIT	DESCRIPTION
7	ALERT_MSK – ALERT# function is enable

BIT	DESCRIPTION
	0 = Enable 1 = Disable
6	STOP_Mnt – Stop Monitor and entry Standby 0 = Monitor 1 = Stop Monitor
0	EN_FaultQueue –Enable Fault Queue function. 0 = Disable. ALERT# will be generated if monitor result of any channel is above or below high/low set point. 1 = Enable. ALERT# will be generated if monitor result of any channel is three successive times above or below high/low set point.

7.2.4 Register : Conversion Rate

Location : Read = Address 04h Write = Address 0Ah

Type : Read/Write

Power on default value : 08

BIT	7	6	5	4	3	2	1	0
NAME	Reserved				ConvRate			
DEFAULT	Reserved				1	0	0	0

BIT<D7:D0>	FREQUENCY/TIME
00h	0.0625Hz / 16sec
01h	0.125Hz / 8sec
02h	0.25Hz / 4sec
03h	0.5Hz / 2sec
04h	1Hz / 1sec
05h	2Hz / 0.5sec
06h	4Hz / 0.25sec
07h	8Hz / 0.125sec
08h	16Hz / 0.0625sec
09h-FFh	Reserved

7.2.5 Register : Local Diode Temperature Alert Temperature

Location : Read = Address 05h Write = Address 0Bh

Type : Read/Write

Power on default value : Hardware strapping.

BIT	7	6	5	4	3	2	1	0
NAME	LDT Alert Temperature							
VALUE	SIGN	64	32	16	8	4	2	1
DEFAULT	Hardware strapping							

7.2.6 Register : One Shot Conversion

Location : Address 0Fh

Type : Write Only

BIT	DESCRIPTION
7-0	One Shot Conversion – When enter Stop Monitor state, to fill any value into this register will trigger one temperature conversion cycle.

7.2.7 Register : Customer Data Log Registers

Location : Address 2Dh, 2Eh, 2Fh

Type : Read/Write

Power on default value : 00

BIT	7	6	5	4	3	2	1	0
NAME	Customer Data Log Register							
DEFAULT	00h							

7.2.8 Register : Alert Mode Setting

Location : Address BFh

Type : Read/Write

Power on default value : 01

BIT	7	6	5	4	3	2	1	0
NAME	Reserved							ALERT_MD
DEFAULT	01h							

BIT	DESCRIPTION
0	ALERT_MD – ALERT mode configuration 0 = Interrupt or SMBus™ alert mode , 1 = Comparator mode

* Note: To enable Interrupt or SMBus™ alert mode, the address[21h] must be written 0x00 at the same time.

Register : Chip ID

Location : Address FDh

Type : Read Only

Power on default value : 50

BIT	DESCRIPTION
7-0	Chip ID. Chip ID of NCT7717U is 50h

7.2.9 Register : Vendor ID

Location : Address FEh

Type : Read Only

Power on default value : 50

BIT	DESCRIPTION
7-0	Vendor ID. Vendor ID of NCT7717U is 50h

7.2.10 Register : Device ID

Location : Address FFh

Type : Read Only

Power on default value: 9x

BIT	DESCRIPTION
7-0	Device ID. Device ID of NCT7717U is 9xh (x=0,1,2...)

8. ELECTRICAL CHARACTERISTICS

8.1 Absolute Maximum Ratings

PARAMETER	RATING	UNIT
Power Supply Voltage	3.3V \pm 5%	V
Input Voltage	-0.3 to +3.6	V
Operating Temperature	-40 to +125	$^{\circ}$ C
Storage Temperature	-55 to +150	$^{\circ}$ C

Note: Exposure to conditions beyond those listed under Absolute Maximum Ratings may adversely affect the life and reliability of the device.

8.2 DC Characteristics

($T_a = 0^{\circ}$ C to 70° C, VDD = 3.3V \pm 5%, GND = 0V)

PARAMETER	SYM.	MIN.	TYP.	MAX.	UNIT	CONDITIONS
OD ₁₂ – Open-drain output pin with source-sink capability of 12 mA						
Output Low Voltage	V _{OL}			0.4	V	I _{OL} = 12 mA
IN _{ts} - TTL level Schmitt-triggered input pin						
Input Low Voltage	V _{IL}			0.8	V	VDD = 3.3V
Input High Voltage	V _{IH}	2.0			V	VDD = 3.3V
Input High Leakage	I _{LIH}			+10	μ A	VIN=3.3V
Input Low Leakage	I _{LIL}			-10	μ A	VIN=0V

8.3 AC Characteristics

SMBus™ Interface

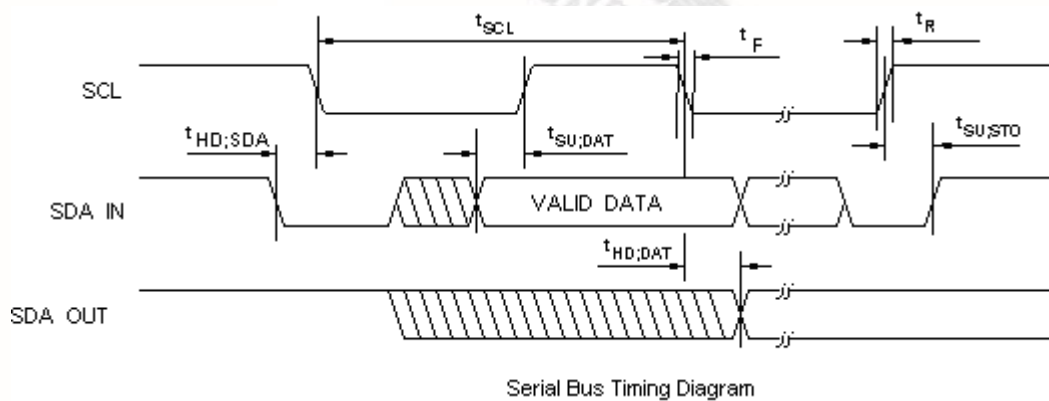

PARAMETER	SYMBOL	MIN.	MAX.	UNIT
SCL clock period	t_{SCL}	2.5		uS
Start condition hold time	$t_{HD;SDA}$	1.5		uS
Stop condition setup-up time	$t_{SU;STO}$	1		uS
DATA to SCL setup time	$t_{SU;DAT}$	120		nS
DATA to SCL hold time	$t_{HD;DAT}$	5		nS
SCL and SDA rise time	t_R		1.0	uS
SCL and SDA fall time	t_F		300	nS

9. ORDER INSTRUCTION

PART NO.	PACKAGE	SUPPLIED AS	PRODUCTION FLOW
NCT7717U	SOT-23, 5pin Green Package	T Shape: 3,000 units/T&R	Commercial, 0°C to +70°C

10. TOP MARKING SPECIFICATION

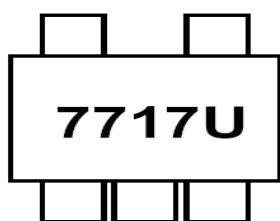

1st Line : 7717U means part number NCT7717U

11. TAPING SPECIFICATION

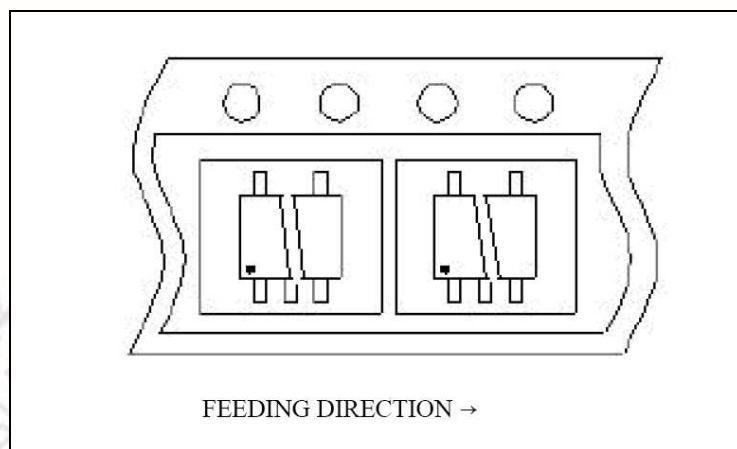

12. PACKAGE DRAWING AND DIMENSIONS

SOT-23 (5L) 1.6X2.9 MM²

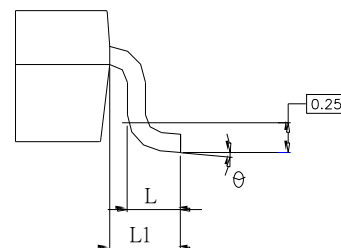
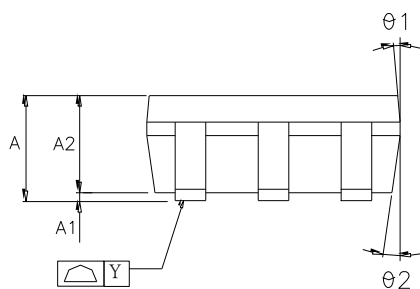
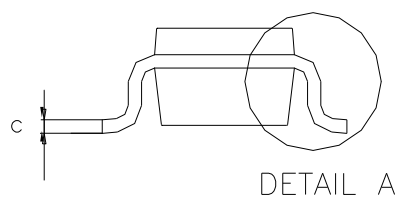
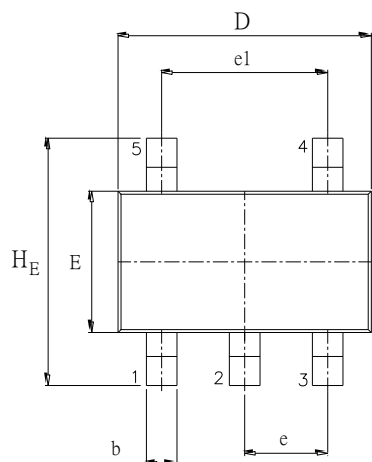

CONTROL DIMENSIONS ARE IN MILLIMETERS

SYMBOL	MILLIMETERS			INCH		
	MIN.	NOM.	MAX.	MIN.	NOM.	MAX.
A	1.05	1.20	1.35	0.041	0.047	0.053
A1	0.05	0.10	0.15	0.002	0.004	0.006
A2	1.00	1.10	1.2	0.039	0.043	0.047
b	0.25	-	0.50	0.010	-	0.020
c	0.08	-	0.20	0.003	-	0.008
D	2.70	2.90	3.00	0.106	0.114	0.118
HE	2.60	2.80	3.00	0.102	0.110	0.118
E	1.50	1.60	1.70	0.059	0.063	0.067
e	0.95 BSC			0.037 BSC		
e1	1.90 BSC.			0.075 BSC.		
L	0.35	0.45	0.55	0.014	0.018	0.022
L1	0.60 REF.			0.024 REF.		
theta	0°	5°	10°	0°	5°	10°
theta1	3°	5°	7°	3°	5°	7°
theta2	6°	8°	10°	6°	8°	10°
Y	-	-	0.10	-	-	0.004

DETAIL A

Important Notice

Nuvoton Products are neither intended nor warranted for usage in systems or equipment, any malfunction or failure of which may cause loss of human life, bodily injury or severe property damage. Such applications are deemed, "Insecure Usage".

Insecure usage includes, but is not limited to: equipment for surgical implementation, atomic energy control instruments, airplane or spaceship instruments, the control or operation of dynamic, brake or safety systems designed for vehicular use, traffic signal instruments, all types of safety devices, and other applications intended to support or sustain life.

All Insecure Usage shall be made at customer's risk, and in the event that third parties lay claims to Nuvoton as a result of customer's Insecure Usage, customer shall indemnify the damages and liabilities thus incurred by Nuvoton.

*Please note that all data and specifications are subject to change without notice.
All the trademarks of products and companies mentioned in this datasheet belong to their respective owners.*