



Chipsmall Limited consists of a professional team with an average of over 10 year of expertise in the distribution of electronic components. Based in Hongkong, we have already established firm and mutual-benefit business relationships with customers from,Europe,America and south Asia,supplying obsolete and hard-to-find components to meet their specific needs.

With the principle of “Quality Parts,Customers Priority,Honest Operation,and Considerate Service”,our business mainly focus on the distribution of electronic components. Line cards we deal with include Microchip,ALPS,ROHM,Xilinx,Pulse,ON,Everlight and Freescale. Main products comprise IC,Modules,Potentiometer,IC Socket,Relay,Connector.Our parts cover such applications as commercial,industrial, and automotives areas.

We are looking forward to setting up business relationship with you and hope to provide you with the best service and solution. Let us make a better world for our industry!



Contact us

Tel: +86-755-8981 8866 Fax: +86-755-8427 6832

Email & Skype: info@chipsmall.com Web: www.chipsmall.com

Address: A1208, Overseas Decoration Building, #122 Zhenhua RD., Futian, Shenzhen, China



NCV7680PWR22GEVB

NCV7680 Evaluation Board User's Manual



ON Semiconductor®

<http://onsemi.com>

EVAL BOARD USER'S MANUAL

Description

The NCV7680 is an octal LED driver designed for automotive LED rear combination lamps. External programmability of the NCV7680 allows the user to set the tail current and stop currents using a single resistor for each function. An optional external FET is used to help distribute power for high power systems.

The Evaluation Board includes both an NCV7680 (octal driver) and NTD2955 (FET). A switch on the board allows the user to evaluate functionality with and without the FET.

The DIAG pin is brought out for reporting of open circuit conditions.

The LED's mounted on the demo board are jumpered giving flexibility for evaluating customer defined loads.

Part Features

- Constant Current Outputs for LED String Drive
- Open LED String Diagnostic with Open-Collector Output
- Soft Start Eliminates EMI Concerns
- Low Dropout Operation for Pre-Regulator Applications
- External Modulation Capable

- On-chip 1 kHz Tail PWM Dimming
- Single Resistor for Stop Current Set Point
- Single Resistor for Tail Dimming Set Point
- Overvoltage & Overtemperature Set Back Power Limitation
- AEC Q100 Qualified
- 16 Lead SOW Exposed Pad
- Lead-free Packaging

Board Features

- Tail Input Switch – Outputs are in the PWM Mode
- STOP Input Switch – Outputs are 100% On
- DIAG Output – Open Circuits are Reported
- LED Isolation – On-board LEDs can be Removed with Jumpers for Alternative LED Evaluation
- STOP Programming Current – Programming Resistor can be Adjusted Externally by Jumper Removal
- Tail Programming Duty Cycle – Programming Resistor can be Adjusted Externally by Jumper Removal



Figure 1. NCV7680PWR22GEVB Photo

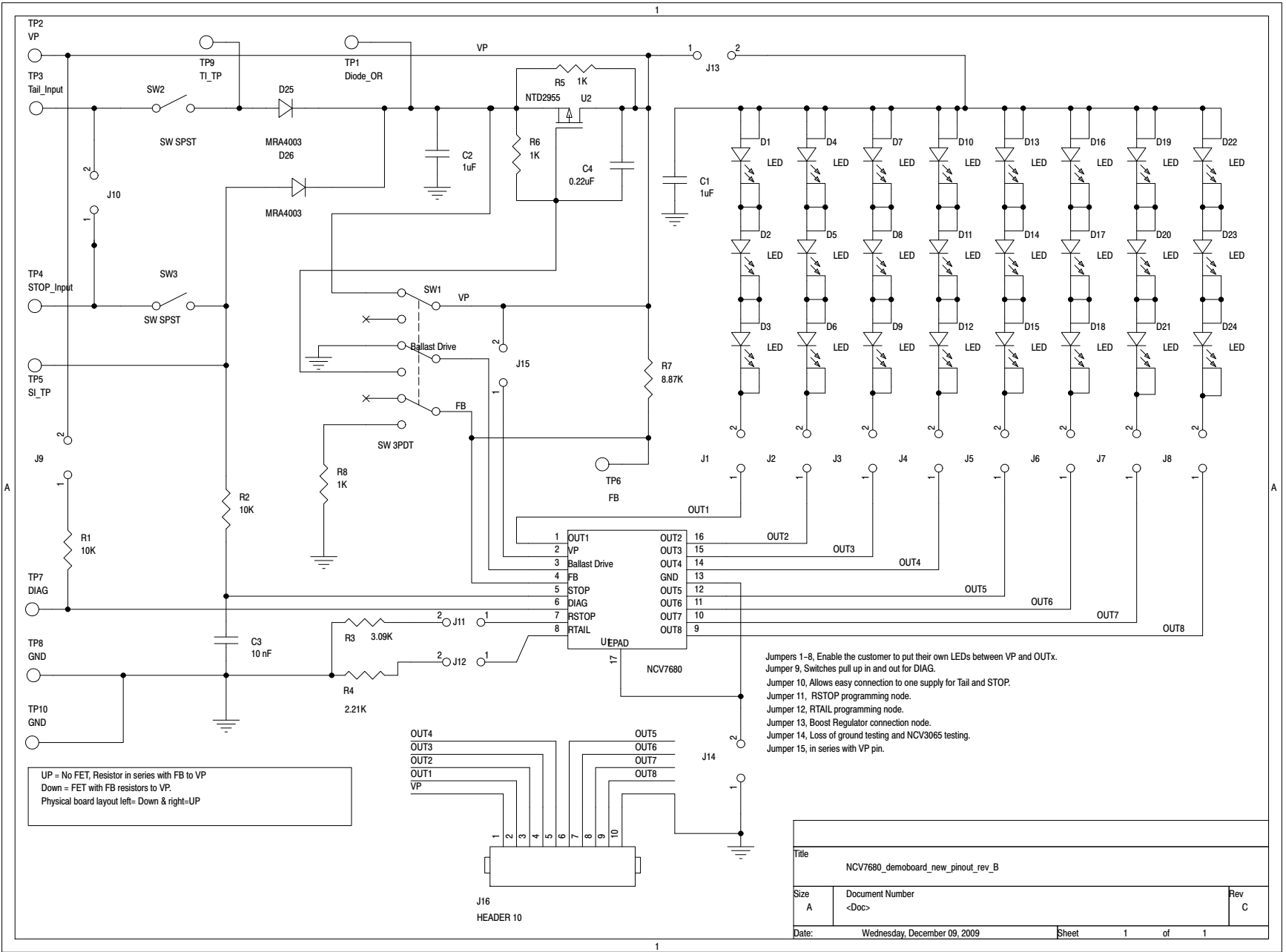

UP - No FET, Resistor in series with FB to VP
 Down - FET with FB resistors to VP.
 Physical board layout left= Down & right=UP

- Jumpers 1-8, Enable the customer to put their own LEDs between VP and OUTx.
- Jumper 9, Switches pull up in and out for DIAG.
- Jumper 10, Allows easy connection to one supply for Tail and STOP.
- Jumper 11, RSTOP programming node.
- Jumper 12, RTAIL programming node.
- Jumper 13, Boost Regulator connection node.
- Jumper 14, Loss of ground testing and NCV3065 testing.
- Jumper 15, in series with VP pin.

Title		
NCV7680_demoboard_new_pinout_rev_B		
Size	Document Number	Rev
A	<Doc>	C
Date:	Wednesday, December 09, 2009	Sheet 1 of 1

Figure 2. NCV7680PWR22GEVB Schematic

NCV7680PWR22GEVB

Powering up the Board

Equipment Needed – 1 power supply (3/4 Amp)

1. There are 15 jumpers on the board. Start with all 15 jumpers connected. Jumper locations are shown in Figure 3. A list of jumper functionality is shown in the board schematic (Figure 2). Typical connections to the evaluation board are shown in Figure 4.

2. Position switch 1 (SW1) for either external ballast connection (left) or no external ballast connection (right).
3. Connect the power supply.
4. Toggle switch 2 (SW2) for display of the PWM mode (tail).
5. Toggle switch 3 (SW3) for display of 100% duty cycle (STOP).

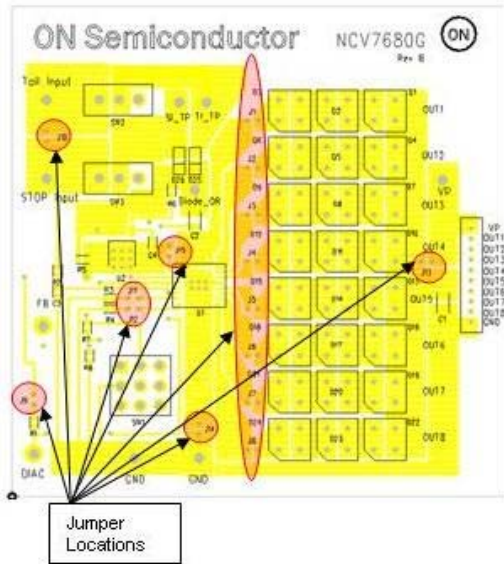

Figure 3. Jumper Locations

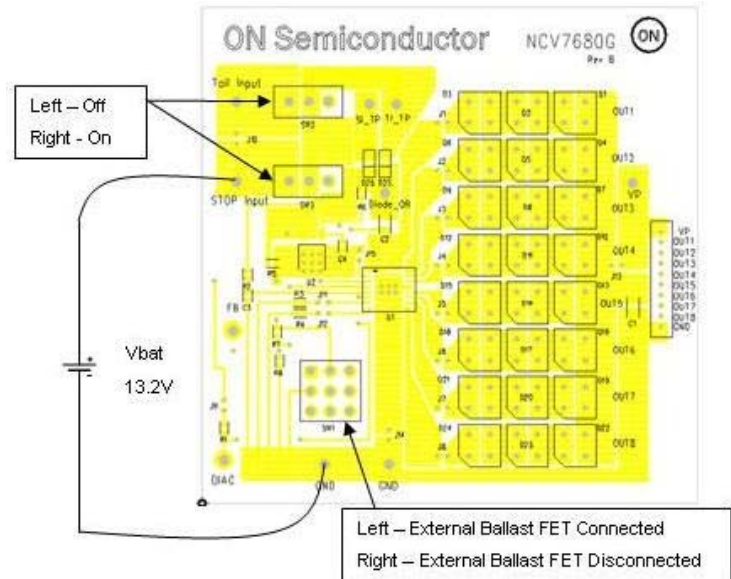

Figure 4. Power Connections

NCV7680PWR22GEVB

Jumpers 1-8

Jumpers 1-8 highlight the open circuit functionality of diagnostic pin (DIAG). Monitor DIAG while creating an open circuit by removing any on these jumpers (1-8). DIAG functionality will conform to the variables shown in Table 1.

Table 1. DIAG Functionality

Stop Input	Tail Input	OUTX Current 1 - 8	Fault State	DIAG State
0	0	OFF	-	HighZ*
1	0	I _{STOP}	Normal	Low
1	0	I _{STOP}	Open String	High*
0	1	PWM	Don't Care	High*
1	1	I _{STOP}	Normal	Low
1	1	I _{STOP}	Open String	High*

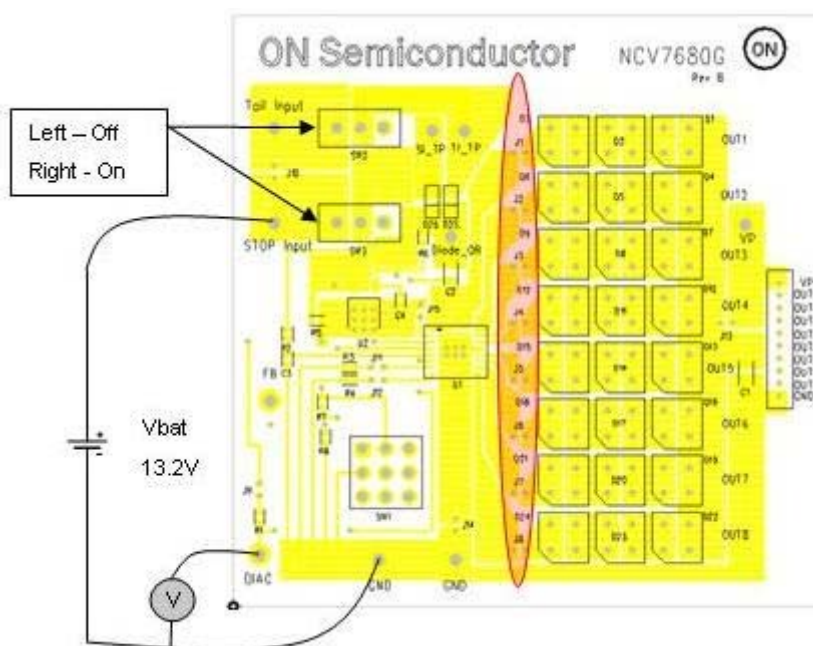

Figure 5. Open Circuit Testing

NCV7680PWR22GEVB

Jumper 9

Jumper 9 disconnects the PC board pullup resistor and allows the user to interface with his own component and power supply to the DIAG pin.

Disconnect Jumper 9. Connect the external resistor to a separate supply. The DIAG pin is limited to 45 V per the maximum ratings table.

Figure 6 shows the test setup for using DIAG with a separate supply.

Table 2. MAXIMUM RATINGS (Voltages are with respect to device substrate)

Rating	Value	Unit
VP, Ballast Drive, STOP, DIAG DC Peak Transient	-0.3 to 45 45	V
Output Pin Voltage (OUTX)	-0.3 to 45	V
Output Pin Current (OUTX)	100	mA
Input Voltage (RTAIL, RSTOP, FB)	-0.3 to 5	V
Junction Temperature, T _J	-40 to 150	°C
Peak Reflow Soldering Temperature: Pb-Free 60 to 150 seconds at 217°C (Note NO TAG)	260 peak	°C

Stresses exceeding Maximum Ratings may damage the device. Maximum Ratings are stress ratings only. Functional operation above the Recommended Operating Conditions is not implied. Extended exposure to stresses above the Recommended Operating Conditions may affect device reliability.

1. DIAG is tested under the conditions shown below from the NCV7680 datasheet.

Table 3. ELECTRICAL CHARACTERISTICS

(6 V < VP < 16 V, V, STOP = VP, RSTOP = 3.09 kΩ, RTAIL = 2.21 kΩ, -40°C ≤ T_J ≤ 150°C, unless otherwise noted.)

Characteristic		Min	Typ	Max	Unit
DIAG OUTPUT					
Output Low Voltage	DIAG Active, I _{DIAG} = 1 mA	-	0.1	0.4	V
Output Leakage Current	V _{DIAG} = 5 V	-	-	10	μA

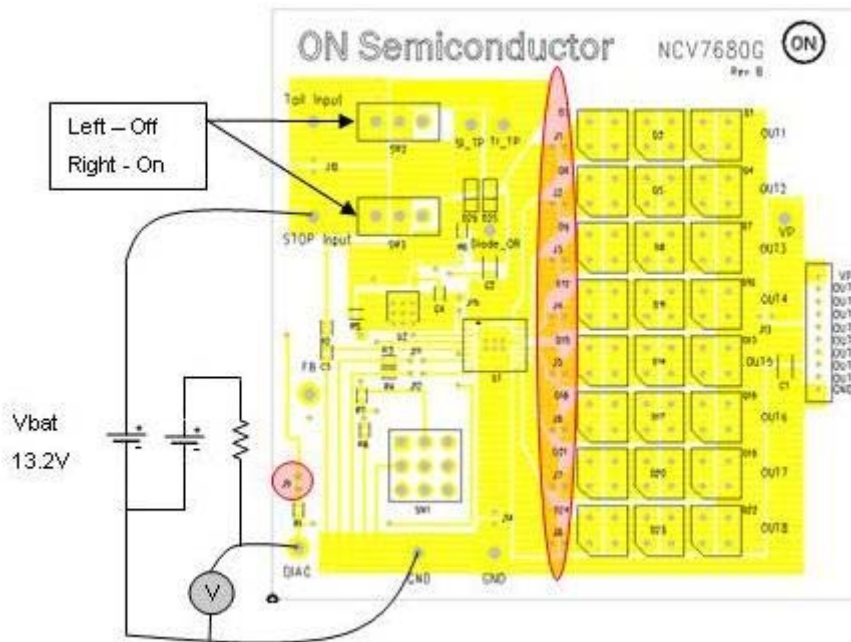

Figure 6. DIAG Connection

NCV7680PWR22GEVB

Jumper 10

Using jumper 10 allows the use of one power supply for both the Tail and STOP functions. Removing J10 allows the use of separate supplies for the Tail Input and the STOP Input.

After removing jumper 10, connect 2 power supplies as shown in Figure 7.

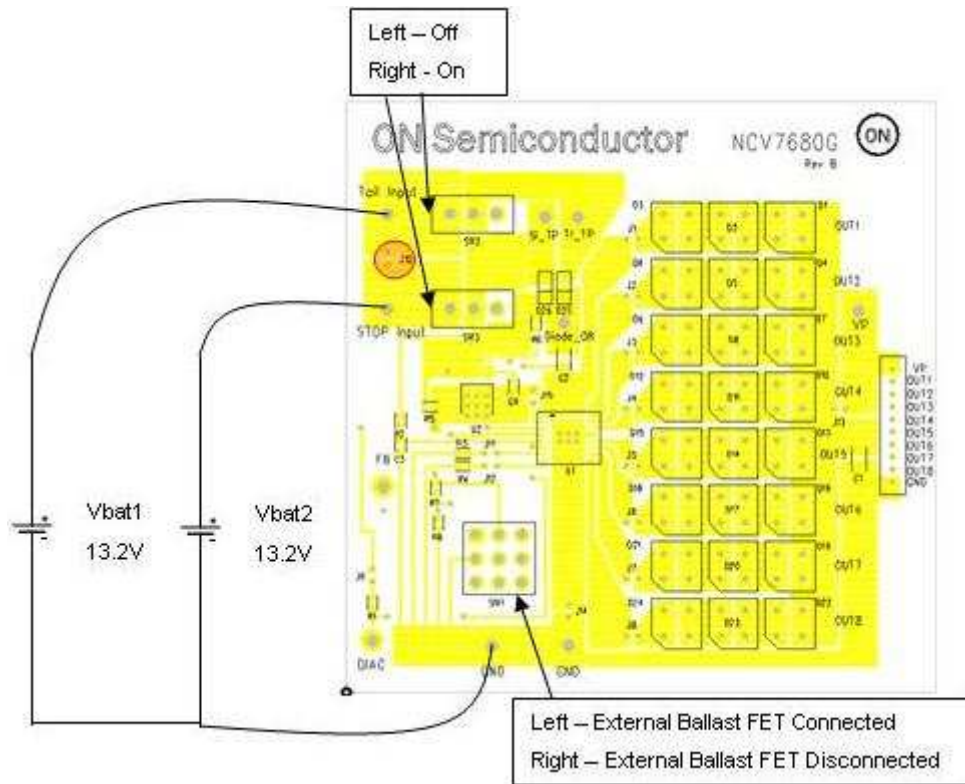

Figure 7.

NCV7680PWR22GEVB

Jumpers 11 and 12

Jumpers 11 and 12 allow the user to program the LED output currents.

Remove the jumper to disconnect the PC board resistor and connect a different value.

Resistor values and resultant output programmed currents can be calculated using these design equations.

$$\text{OUTX} = 100 \times \frac{R_{\text{STOP_BIAS_Voltage}}}{R_{\text{STOP}}} \quad (\text{eq. 1})$$

$$R_{\text{TAIL}} = 4 \times R_{\text{STOP}} \times (\text{DC} + 0.1) \quad (\text{eq. 2})$$

$$R_{\text{STOP_BIAS_Voltage}} = 1.08 \text{ V (typ)}$$

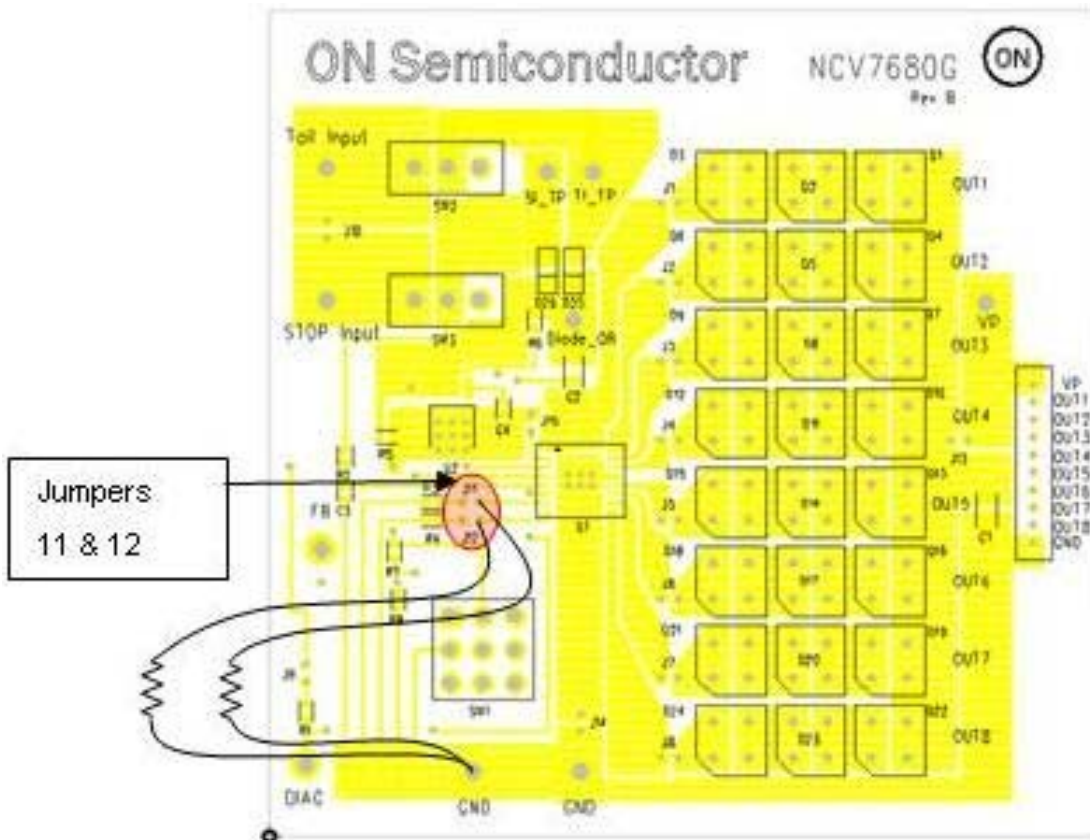

Figure 8. Programming Resistors

NCV7680PWR22GEVB

Jumper 13

Jumper 13 disconnects the common top anode connection of the LED's.

When used with jumpers 1-8 allows the user to drive external LED's. Figure 9 highlights using the connections

on the board edge. Figure 10 highlights an alternative connection. Note, two channels are shown in Figure 10 disconnecting jumpers 1, 2, and 13. This can be expanded for all 8 channels.

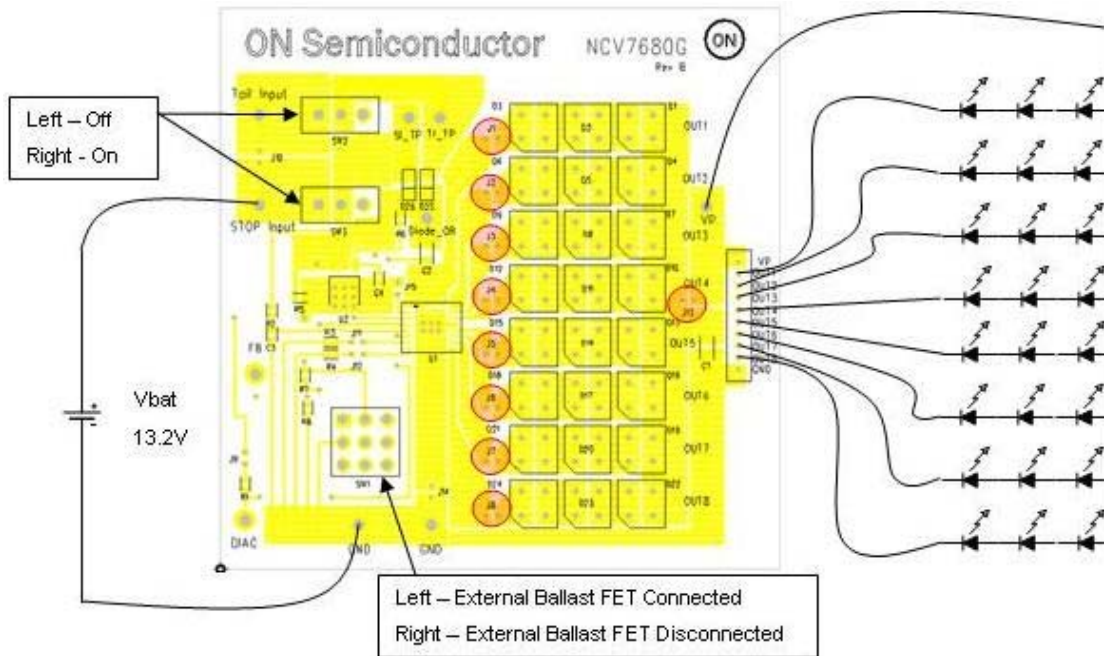

Figure 9. External LED's

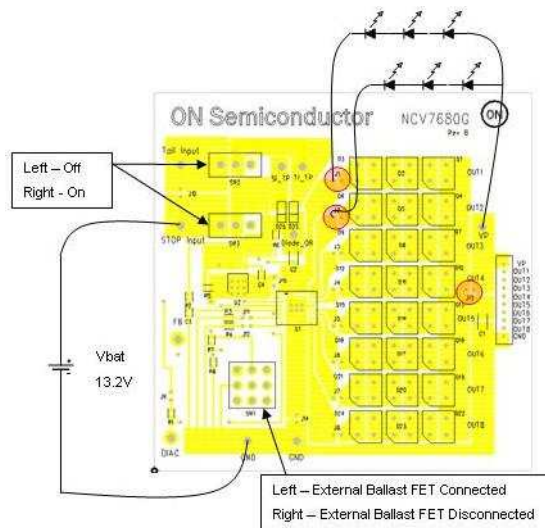

Figure 10. External LED's (alt. connection) (two channels shown)

NCV7680PWR22GEVB

Isolation of VP using jumper 13 will also allow the use of a boost converter to add additional headroom for more LEDs in a string. See Figure 11 for setup.

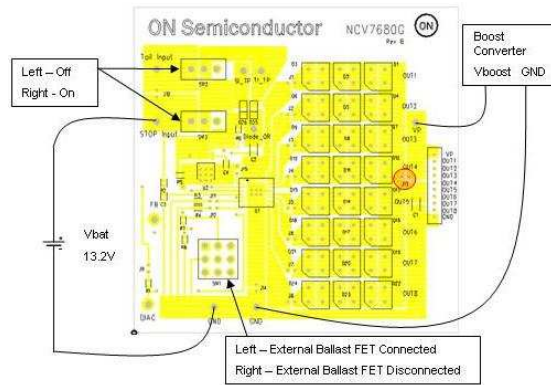

Figure 11. Voltage Boost

Jumper 14

Jumper 14 is the ground connection for the NCV7680. This can be used to measure ground current of the IC or test for loss of ground conditions.

Jumper 15

Jumper 15 is a series connection for VP. This can be used to measure the quiescent current of the NCV7680. Remove jumper 15 and put an ammeter between the pins of the jumper.

Table 4. BILL OF MATERIALS (NCV7680PWR22GEVB Evaluation Board)

Designator	Qty	Description	Value	Tolerance	Footprint	Manufacturer	Manufacturer Part Number	Substitution Allowed	Pb-Free
U1	1	NCV7680 (SOW-16 epad)	-	-	751R_02_B	ON Semiconductor	NCV7680PDWG	No	Yes
U2	1	NTD2955	-	-	DPAK3_SMD	ON Semiconductor	NTD2955T4G	No	Yes
U3, (D25, D26)	2	MRA4003	-	-	SMA_DIODE	ON Semiconductor	MRA4003T3G	No	Yes
D1-D24	24	Superflux LED (Lumileds)	Amber	N/A	LED_SUPERFLUX	Philips	HPWN-BL00-0002	No	Yes
C1,C2	2	Input / Output Capacitor	1 μ F, 50V	(\pm 10%) X7R	1210	KEMET	C1210C105K3RACTU	Yes	Yes
C3	1	Debounce Capacitor	10nF, 50V	(\pm 10%) X7R	0805	AVX	08055C103KAT	Yes	Yes
C4	1	Loop Stabization Capacitor	0.22 μ F, 50V	(\pm 10%) X7R	0805	Murata	GCM21BR71H224KA37L	Yes	Yes
R1, R2	2	Logic I/O Resistor	10k	1%	0805	Yageo America	RC0805FR-0710KL	Yes	Yes
R3	1	Stop Current Program Resistor	3.09k	1%	0805	Yageo America	RC0805FR-073K09L	Yes	Yes
R4	1	Tail Current Program Resistor	2.21k	1%	0805	Yageo America	RC0805FR-072K21L	Yes	Yes
R7	1	VP Program Resistor	8.87k	1%	0805	Yageo America	RC0805FR-078K87L	Yes	Yes
R5, R6, R8	3	VP Support Resistor	1k	1%	0805	Yageo America	RC0805FR-071KL	Yes	Yes
J16	1	Jumper Posts (SIP 10), 100mill spacing	-	-	SIP10	Molex-Waldom Electronics Corp	22-28-4103	Yes	Yes

NCV7680PWR22GEVB

Table 4. BILL OF MATERIALS (NCV7680PWR22GEVB Evaluation Board)

Designator	Qty	Description	Value	Tolerance	Footprint	Manufacturer	Manufacturer Part Number	Substitution Allowed	Pb-Free
J1-J15	30	Jumper Posts 100 mil spacing	-	-	JMP	Molex-Waldom Electronics Corp	22-28-4023	Yes	Yes
J1-J15	15	Jumper	-	-	-	Sullins Electronic Corp	SSC02SYAN	Yes	Yes
TP1-TP10	10	Connector Posts	-	-	TURRET	Vector Electronics	K24C/M	Yes	Yes
SW1	1	Ballast FET enable switch (3PDT)	-	-	NKK_3PDT_M2032	NKK of America	M2032SS1W03-RO	Yes	Yes
SW2, SW3	2	STOP / Tail control switch (SPDT)	-	-	C&K_7101	C&K	7101SYCQE	Yes	Yes

ON Semiconductor and  are registered trademarks of Semiconductor Components Industries, LLC (SCILLC). SCILLC reserves the right to make changes without further notice to any products herein. SCILLC makes no warranty, representation or guarantee regarding the suitability of its products for any particular purpose, nor does SCILLC assume any liability arising out of the application or use of any product or circuit, and specifically disclaims any and all liability, including without limitation special, consequential or incidental damages. "Typical" parameters which may be provided in SCILLC data sheets and/or specifications can and do vary in different applications and actual performance may vary over time. All operating parameters, including "Typicals" must be validated for each customer application by customer's technical experts. SCILLC does not convey any license under its patent rights nor the rights of others. SCILLC products are not designed, intended, or authorized for use as components in systems intended for surgical implant into the body, or other applications intended to support or sustain life, or for any other application in which the failure of the SCILLC product could create a situation where personal injury or death may occur. Should Buyer purchase or use SCILLC products for any such unintended or unauthorized application, Buyer shall indemnify and hold SCILLC and its officers, employees, subsidiaries, affiliates, and distributors harmless against all claims, costs, damages, and expenses, and reasonable attorney fees arising out of, directly or indirectly, any claim of personal injury or death associated with such unintended or unauthorized use, even if such claim alleges that SCILLC was negligent regarding the design or manufacture of the part. SCILLC is an Equal Opportunity/Affirmative Action Employer. This literature is subject to all applicable copyright laws and is not for resale in any manner.

PUBLICATION ORDERING INFORMATION

LITERATURE FULFILLMENT:
Literature Distribution Center for ON Semiconductor
P.O. Box 5163, Denver, Colorado 80217 USA
Phone: 303-675-2175 or 800-344-3860 Toll Free USA/Canada
Fax: 303-675-2176 or 800-344-3867 Toll Free USA/Canada
Email: orderlit@onsemi.com

N. American Technical Support: 800-282-9855 Toll Free
USA/Canada
Europe, Middle East and Africa Technical Support:
Phone: 421 33 790 2910
Japan Customer Focus Center
Phone: 81-3-5817-1050

ON Semiconductor Website: www.onsemi.com
Order Literature: <http://www.onsemi.com/orderlit>
For additional information, please contact your local Sales Representative