



Chipsmall Limited consists of a professional team with an average of over 10 year of expertise in the distribution of electronic components. Based in Hongkong, we have already established firm and mutual-benefit business relationships with customers from,Europe,America and south Asia,supplying obsolete and hard-to-find components to meet their specific needs.

With the principle of “Quality Parts,Customers Priority,Honest Operation,and Considerate Service”,our business mainly focus on the distribution of electronic components. Line cards we deal with include Microchip,ALPS,ROHM,Xilinx,Pulse,ON,Everlight and Freescale. Main products comprise IC,Modules,Potentiometer,IC Socket,Relay,Connector.Our parts cover such applications as commercial,industrial, and automotives areas.

We are looking forward to setting up business relationship with you and hope to provide you with the best service and solution. Let us make a better world for our industry!



Contact us

Tel: +86-755-8981 8866 Fax: +86-755-8427 6832

Email & Skype: info@chipsmall.com Web: www.chipsmall.com

Address: A1208, Overseas Decoration Building, #122 Zhenhua RD., Futian, Shenzhen, China



NCV7680

Linear Current Regulator and Controller for Automotive LED Rear Combination Lamps

The NCV7680 consists of eight linear programmable constant current sources. The part is designed for use in the regulation and control of LED based Rear Combination Lamps for automotive applications. System design with the NCV7680 allows for two brightness levels, one for stop and one for tail illumination, or optional PWM control can also be implemented.

Discrete LED brightness levels are easily programmed (stop current value, tail duty cycle value) optional external ballast FET allows for power distribution on designs requiring high currents. Set back power limit reduces the drive current during overvoltage conditions. This is most useful for low current applications when no external FET is used.

Features

- Constant Current Outputs for LED String Drive
- LED Drive Current up to 75 mA per Channel
- Open LED String Diagnostic with Open-Drain Output
- Slew Rate Control Eliminates EMI Concerns
- Low Dropout Operation for Pre-Regulator Applications
- External Modulation Capable
- On-chip 1 kHz Tail PWM Dimming
- Single Resistor for Stop Current Set Point
- Single Resistor for Tail Dimming Set Point
- Overvoltage Set Back Power Limitation
- AEC Q100 Qualified
- 16 Lead SOICW Exposed Pad
- This is a Pb-Free Device

Applications

- Rear Combination Lamps (RCL)
- Daytime Running Lights (DRL)
- Fog Lights
- Center High Mounted Stop Lamps (CHMSL) Arrays
- Turn Signal and Other Externally Modulated Applications
- LCD Back Lighting



ON Semiconductor®

<http://onsemi.com>

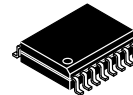

SOIC-16 WB
PW SUFFIX
CASE 751AG

MARKING DIAGRAM

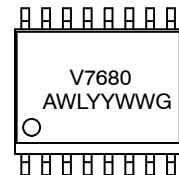

A = Assembly Location
WL = Wafer Lot
YY = Year
WW = Work Week
G = Pb-Free Device

ORDERING INFORMATION

Device	Package	Shipping†
NCV7680PWR2G	SOIC-16WB (Pb-Free)	1000 / Tape & Reel

†For information on tape and reel specifications, including part orientation and tape sizes, please refer to our Tape and Reel Packaging Specifications Brochure, BRD8011/D.

NCV7680

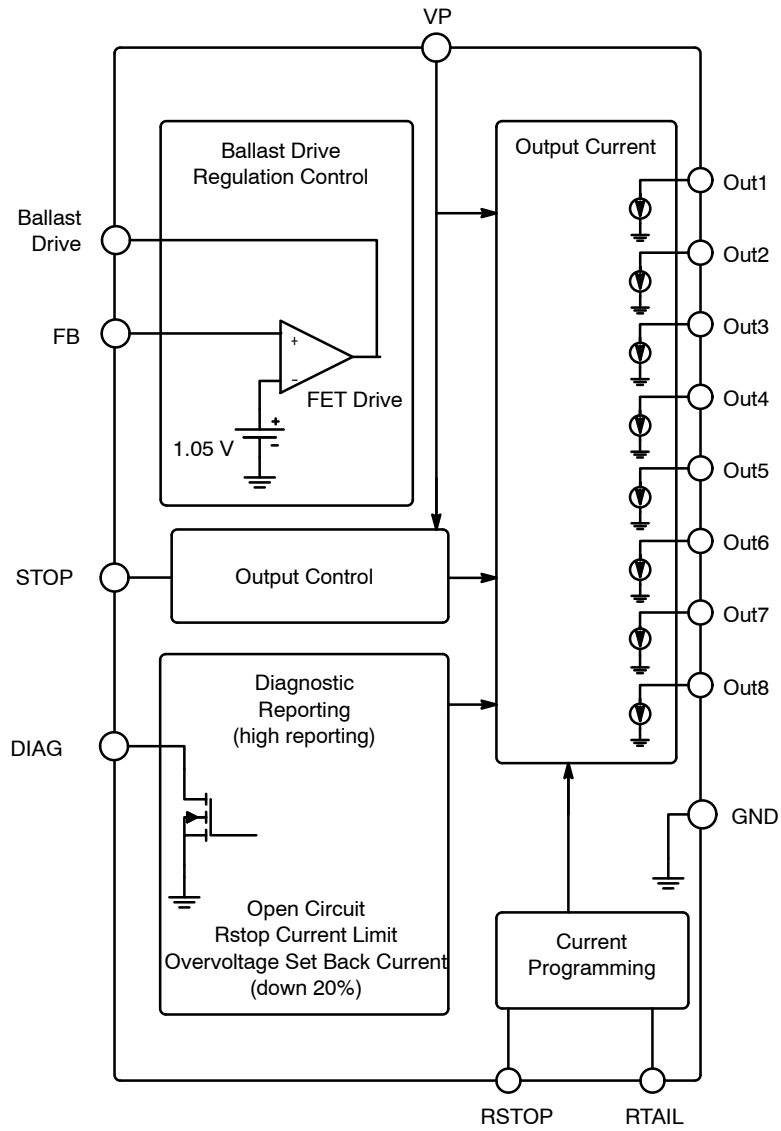

Figure 1. Simple Block Diagram

NCV7680

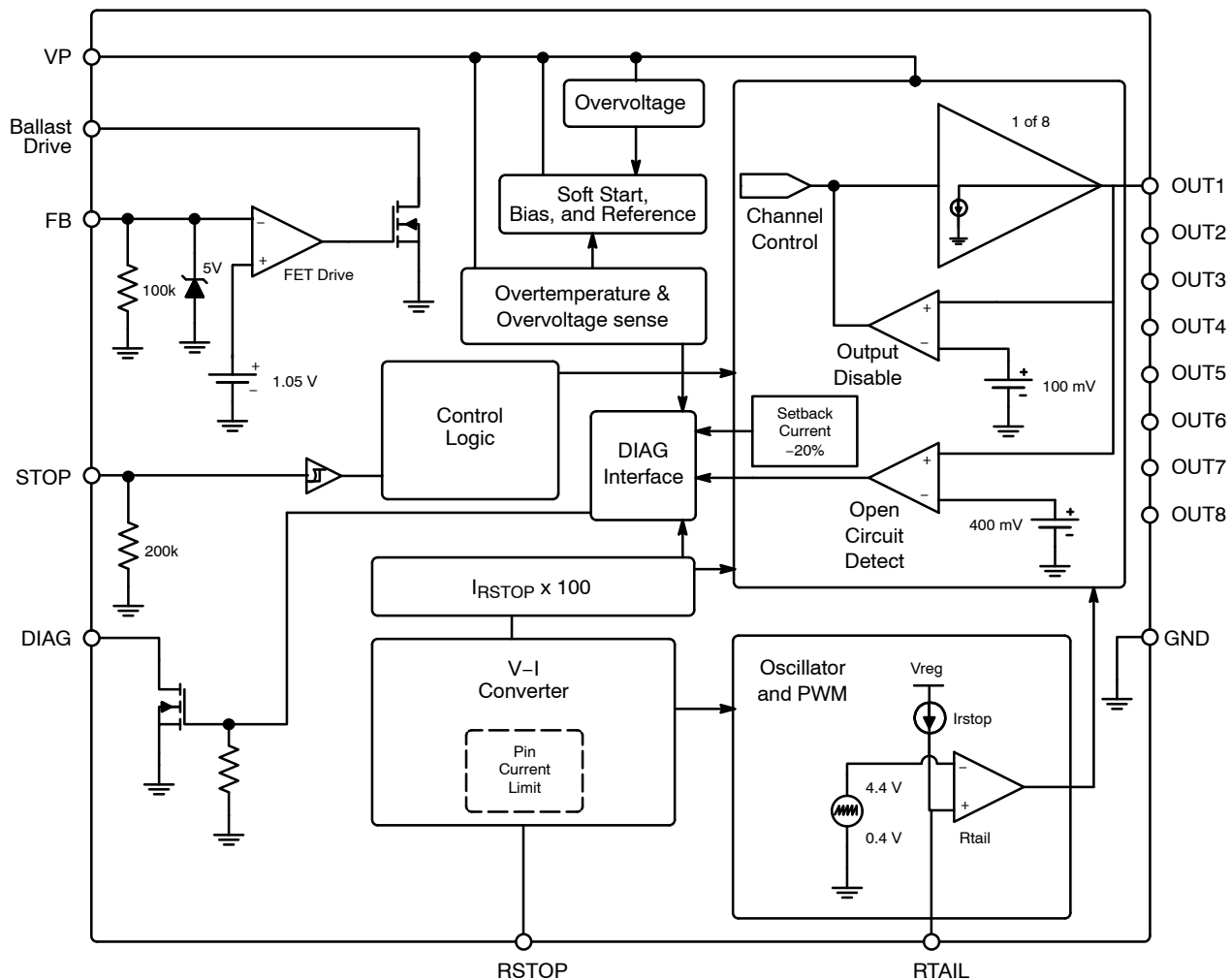

Figure 2. Detailed Block Diagram

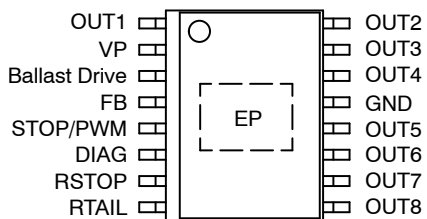

Figure 3. Pinout Diagram

NCV7680

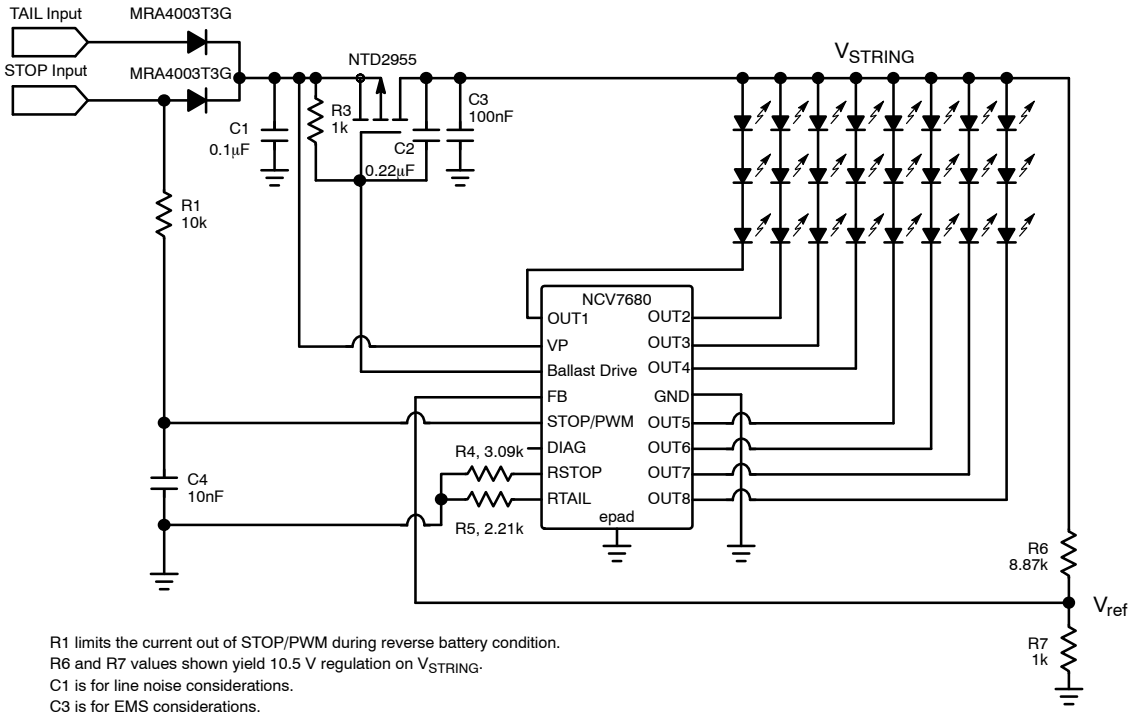

Figure 4. Application Diagram with External FET Ballast Transistor

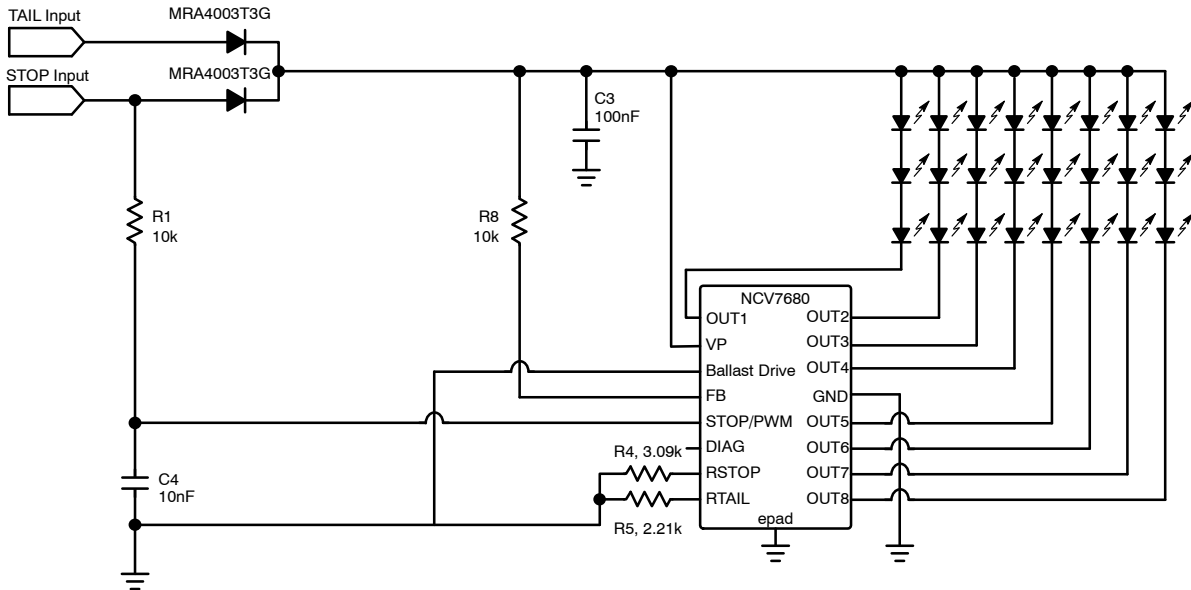

Figure 5. Application Diagram without the FET Ballast Transistor

When using the NCV7680 without the FET ballast transistor, tie the FB Pin to VP through a 10k resistor.

NCV7680

Table 1. APPLICATION I/O TRUTH TABLE (FB = V_{ref}) (Reference Figure 2)

Stop Input	Tail Input	OUTX Current (1-8)	Fault State*	DIAG State
0	0	OFF	-	HIGHZ**
1	0	I_{STOP}	NORMAL	LOW
1	0	I_{STOP}	OPEN CIRCUIT***	HIGH**
0	1	PWM	DO NOT CARE	HIGH**
1	1	I_{STOP}	NORMAL	LOW
1	1	I_{STOP}	OPEN CIRCUIT***	HIGH**

* Open Circuit, R_{STOP} Current Limit, and Set Back Current Limit down 20%

** Pullup resistor to DIAG

*** OPEN CIRCUIT = Any string open

0 = LOW

1 = HIGH

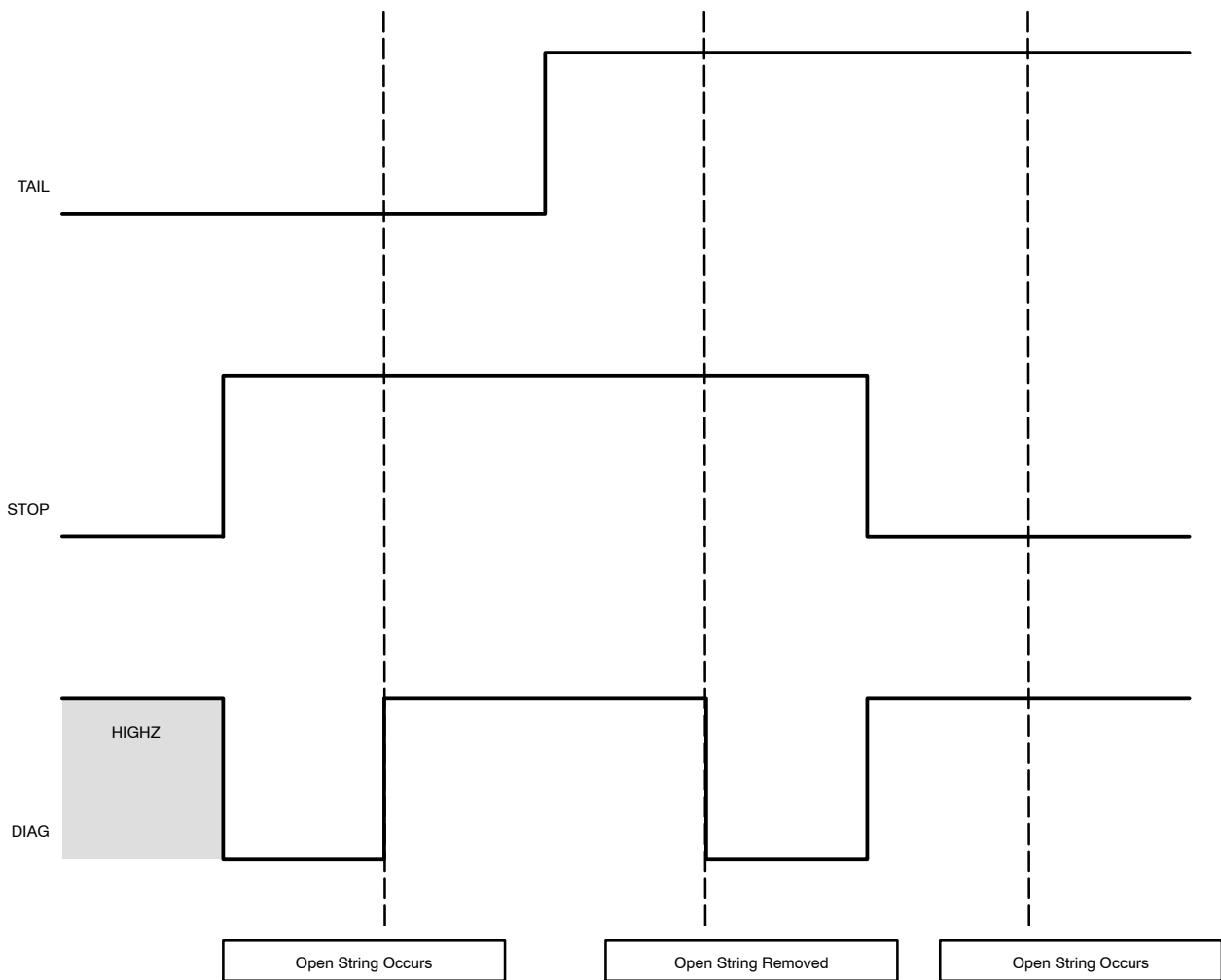

Figure 6. DIAG Timing Diagram

NCV7680

Table 2. PIN FUNCTION DESCRIPTION (16 Pin SO Wide Exposed Pad Package)

Pin #	Label	Description
1	OUT1	Channel 1 constant current output to LED. Unused pin should be grounded.
2	VP	Supply Voltage Input.
3	Ballast Drive	Gate drive for external power distribution PFET. Ground if not used.
4	FB	Feedback Sense node for V_P regulation. Use feedback resistor divider or connect to V_P with a 10k resistor.
5	STOP/PWM	Stop Logic Input. External Modulation Input.
6	DIAG	Open-drain diagnostic output. Reporting Open Circuit, R_{STOP} Current Limit, and Overvoltage Set Back Current down 20%. Normal Operation = LOW. Ground if not used.
7	RSTOP	Stop current bias program resistor.
8	RTAIL	Tail current duty cycle PWM program resistor. Ground if using external modulation.
9	OUT8	Channel 8 constant current output to LED. Unused pin should be grounded.
10	OUT7	Channel 7 constant current output to LED. Unused pin should be grounded.
11	OUT6	Channel 6 constant current output to LED. Unused pin should be grounded.
12	OUT5	Channel 5 constant current output to LED. Unused pin should be grounded.
13	GND	Ground.
14	OUT4	Channel 4 constant current output to LED. Unused pin should be grounded.
15	OUT3	Channel 3 constant current output to LED. Unused pin should be grounded.
16	OUT2	Channel 2 constant current output to LED. Unused pin should be grounded.
epad*	epad	Ground. Do not connect to pcb traces other than GND.

*Grounding will provide better thermal and electrical performance.

MAXIMUM RATINGS (Voltages are with respect to device substrate)

Rating	Value	Unit
VP, Ballast Drive, STOP, DIAG DC Peak Transient	-0.3 to 45 45	V
Output Pin Voltage (OUTX)	-0.3 to 45	V
Output Pin Current (OUTX)	100	mA
Input Voltage (RTAIL, RSTOP, FB)	-0.3 to 5	V
Junction Temperature, T_J	-40 to 150	°C
Peak Reflow Soldering Temperature: Pb-Free 60 to 150 seconds at 217°C (Note 1)	260 peak	°C

Stresses exceeding Maximum Ratings may damage the device. Maximum Ratings are stress ratings only. Functional operation above the Recommended Operating Conditions is not implied. Extended exposure to stresses above the Recommended Operating Conditions may affect device reliability.

- For additional information, see or download ON Semiconductor's Soldering and Mounting Techniques Reference Manual, SOLDERRM/D, and Application Note AND8003/D.

NCV7680

Table 3. ATTRIBUTES

Characteristics	Value
ESD Capability Human Body Model (RSTOP Pin) Human Body Model (All Remaining Pins) Machine Model	> ± 1.8 kV > ± 2.0 kV > ± 200 V
Moisture Sensitivity Level (Note 2)	MSL 1
Storage Temperature	-55°C to 150°C
Package Thermal Resistance (Note 3) Junction-to-Board (R _{ψJB}) Junction-to-Ambient (R _{θJA}) Junction-to-Pin (R _{ψJL})	27°C/W 78°C/W 38°C/W
Meets or exceeds JEDEC Spec EIA/JESD78 IC Latchup Test	

- For additional information, see or download ON Semiconductor's Soldering and Mounting Techniques Reference Manual, SOLDERM/D, and Application Note AND8003/D.
- Values represent typical still air steady-state thermal performance on 1 oz. copper FR4 PCB with 650 mm² copper area.

ELECTRICAL CHARACTERISTICS (6 V < V_P < 16 V, V_{STOP} = V_P, R_{STOP} = 3.09 kΩ, R_{TAIL} = 2.21 kΩ, -40°C ≤ T_J ≤ 150°C, unless otherwise specified) (Note 4)

Characteristic	Conditions	Min	Typ	Max	Unit
----------------	------------	-----	-----	-----	------

GENERAL PARAMETERS

Quiescent Current (I _{OUTx} = 35 mA) STOP Mode, 8 Channel STOP Mode, 4 Channel Tail Mode	V _P = 16 V	-	6.5	8.0	mA
	V _P = 16 V, OUT5 = OUT6 = OUT7 = OUT8 = GND	-	6.4	8.0	
	V _P = 16 V	-	6.0	8.0	

CURRENT SOURCE OUTPUTS

Output Current	OUTX = 1.0 V, T _J = 25°C, 150°C OUTX = 1.0 V, T _J = -40°C	31.5 30.8	35 35	38.5 39.2	mA		
Maximum Regulated Output Current		75	-	-	mA		
Current Matching	-40°C 25°C 150°C	$\left[\frac{2I_{OUTx(min)}}{I_{OUTx(min)} + I_{OUTx(max)}} - 1 \right] \times 100$ $\left[\frac{2I_{OUTx(max)}}{I_{OUTx(min)} + I_{OUTx(max)}} - 1 \right] \times 100$		-7 -6 -5	0 0 0	7 6 5	% % %
Line Regulation	6 V ≤ V _P ≤ 16 V	-	0.6	3.0	mA		
Open Circuit Detection Threshold		0.3	0.4	0.5	V		
Current Slew Rate	I _{OUT} = 35 mA, 10% to 90% Points	-	6.0	25	mA/us		
Overvoltage Set Back Threshold	@ 99% I _{OUT}	16.0	18.7	24.5	V		
Overvoltage Set Back Current	V _P = 20 V	-	94	-	%I _{OUT}		
Diag Reporting of Set Back Current		-	80	-	%I _{OUT}		
Output Disable Threshold		-	100	250	mV		

FET DRIVER

Ballast Drive Leakage Current Sink Current	FB = 1.5 V, Ballast Drive = 3 V FB = 0.5 V, Ballast Drive = 3 V	- 4	0 5	10 -	μA mA
Ballast Drive Reference Voltage		0.95	1.05	1.15	V

- Designed to meet these characteristics over the stated voltage and temperature recommended operating ranges, though may not be 100% parametrically tested in production.
- Guaranteed by design.

NCV7680

ELECTRICAL CHARACTERISTICS (6 V < V_P < 16 V, V_{STOP} = V_P, R_{STOP} = 3.09 kΩ, R_{TAIL} = 2.21 kΩ, -40°C ≤ T_J ≤ 150°C, unless otherwise specified) (Note 4)

Characteristic	Conditions	Min	Typ	Max	Unit
----------------	------------	-----	-----	-----	------

STOP LOGIC

Input High Threshold		1.6	1.9	2.2	V
Input Low Threshold		0.7	0.85	1.1	V
V _{IN} Hysteresis		-	1.05	-	V
Input Bias Current	STOP = 14 V	0	150	300	μA

PROGRAMMING

R _{STOP} Bias Voltage	Stop Current Programming Voltage	0.96	1.08	1.21	V
R _{STOP} K multiplier	I _{OUTX} / I _{RSTOP}	-	100	-	-
R _{STOP} Current Limit		-	1.8	2.2	mA
R _{TAIL} Bias Current	Tail Duty Cycle Programming Current	300	350	450	μA
Duty Cycle	R _{TAIL} = 0.59 V	3.5	5.0	6.5	%
	R _{TAIL} = 1.21 V	17	20	23	%
	R _{TAIL} = 3.29 V	59.5	70	80.5	%

DIAG OUTPUT

Output Low Voltage	DIAG Active, I _{DIAG} = 1 mA	-	0.1	0.40	V
Output Leakage Current	V _{DIAG} = 5 V	-	-	10	μA

THERMAL LIMIT

Thermal Limit Temperature	OUTx Reduction Initiated @ 99% I _{OUT} (Note 5)	150	-	-	°C
Thermal Shutdown	(Note 5)	150	190	-	°C
Thermal Hysteresis	(Note 5)	-	15	-	°C

4. Designed to meet these characteristics over the stated voltage and temperature recommended operating ranges, though may not be 100% parametrically tested in production.
5. Guaranteed by design.

AC CHARACTERISTICS (6 V < V_P < 16 V, V_{STOP} = V_P, R_{STOP} = 3.09 kΩ, R_{TAIL} = 2.21 kΩ, -40°C ≤ T_J ≤ 150°C, unless otherwise specified)

Characteristic	Conditions	Min	Typ	Max	Unit
Stop Turn-on Delay Time	V _{STOP/PWM} 90% to I _{OUTX} 90%	-	14	45	μs
Stop Turn-off Delay Time	V _{STOP/PWM} 10% to I _{OUTX} 10%	-	21	45	μs
PWM Frequency	STOP = 0 V	0.5	1.0	2.1	kHz
Tail Frequency Stabilization Time	V _P step from 0 V to 6 V	-	2.0	4.0	ms
Open Circuit to DIAG Reporting		-	4.0	10	μs

TYPICAL PERFORMANCE CHARACTERISTICS

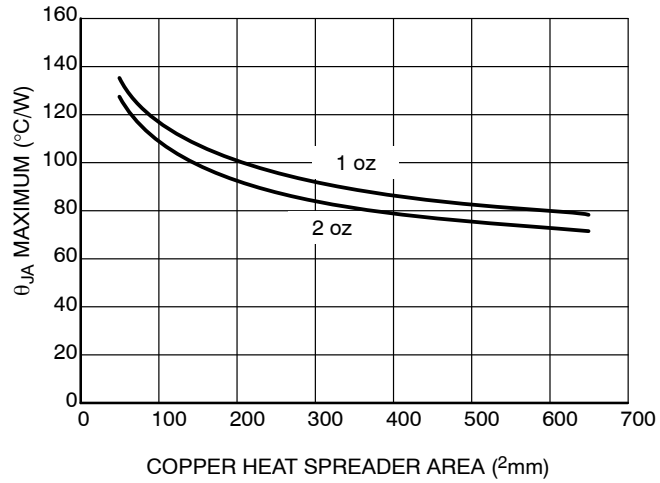

Figure 7. θ_{JA} vs. Copper Spreader Area

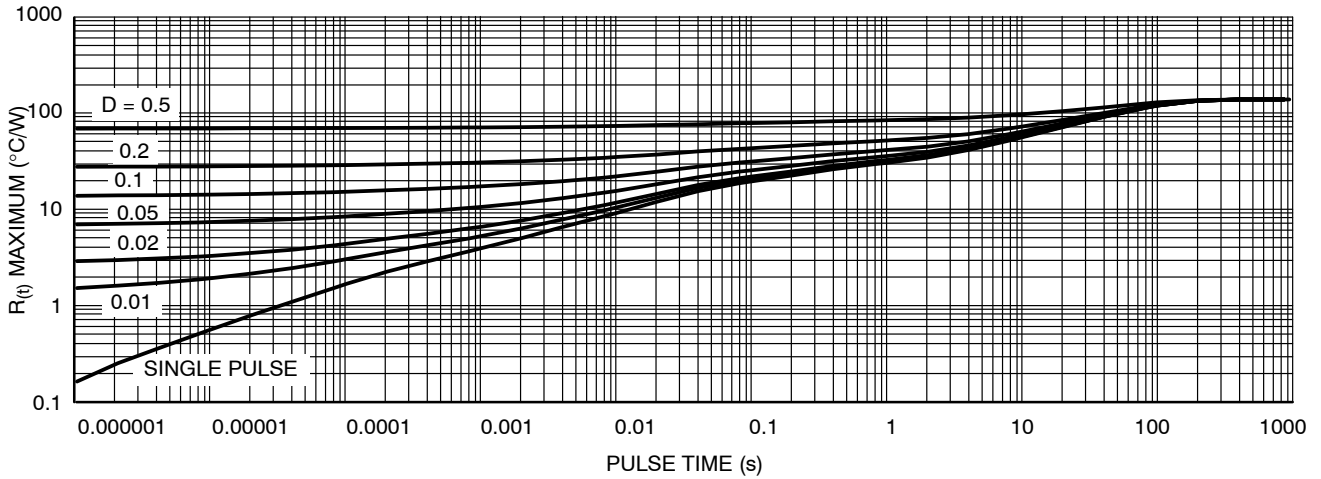

Figure 8. Thermal Duty Cycle Curves on 650 mm^2 Spreader Test Board

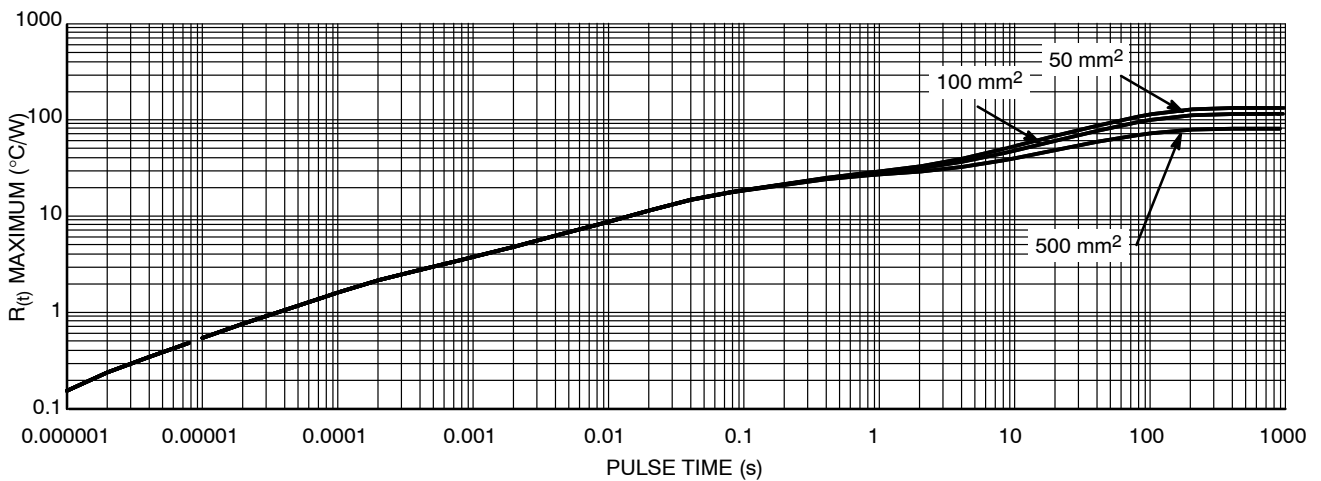

Figure 9. Single Pulse Heating Curve

NCV7680

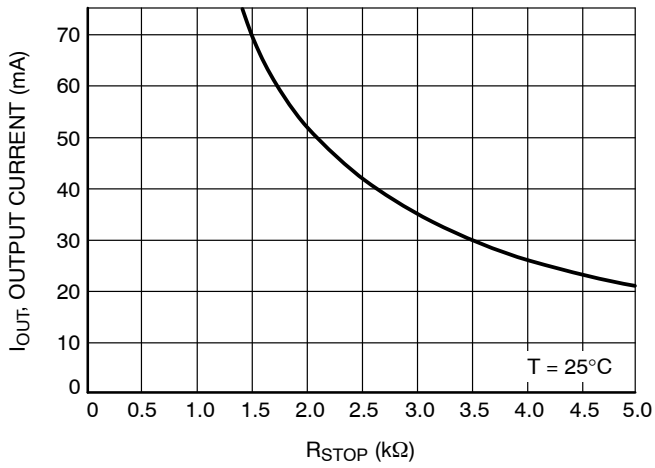

Figure 10. I_{OUT} vs. R_{STOP}

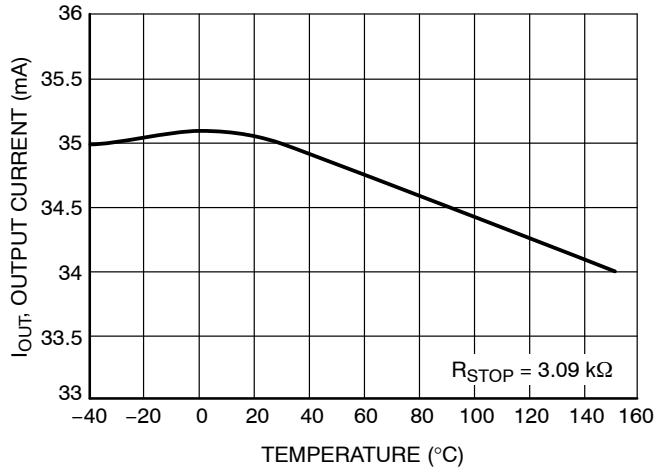

Figure 11. I_{OUT} vs. Temperature

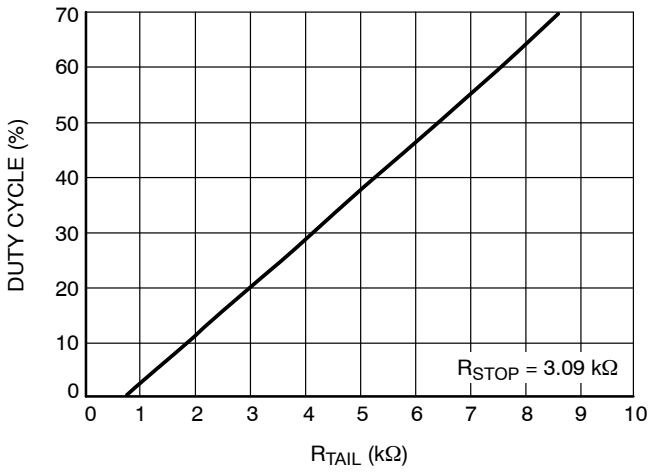

Figure 12. Duty Cycle vs. R_{TAIL}

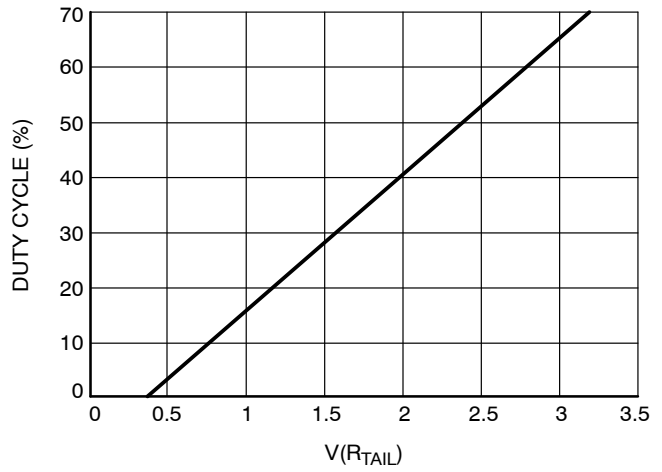

Figure 13. Duty Cycle vs. $V(R_{TAIL})$

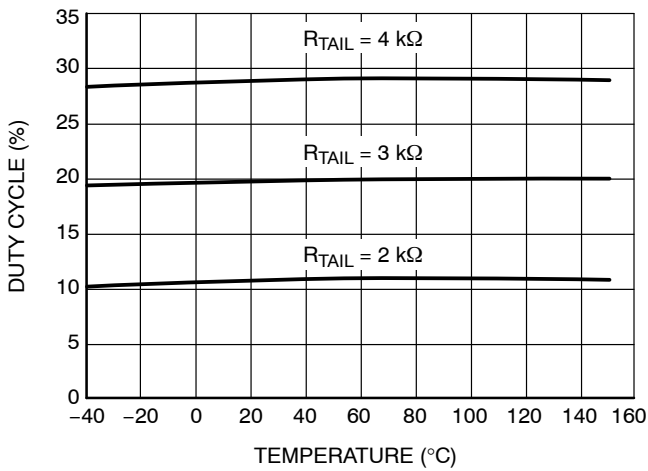

Figure 14. Duty Cycle vs. Temperature

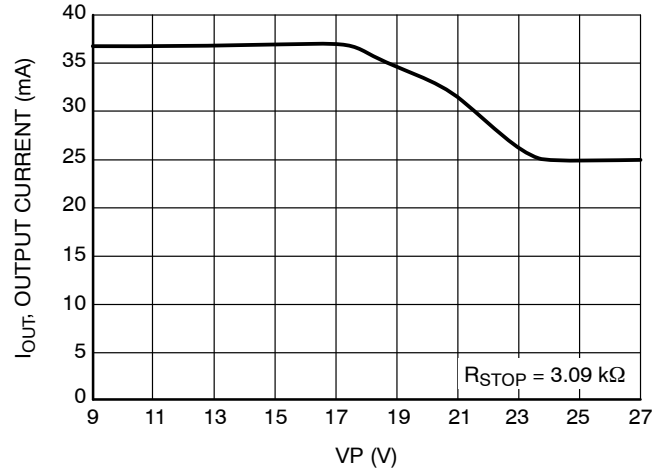

Figure 15. I_{OUT} vs. V_P

NCV7680

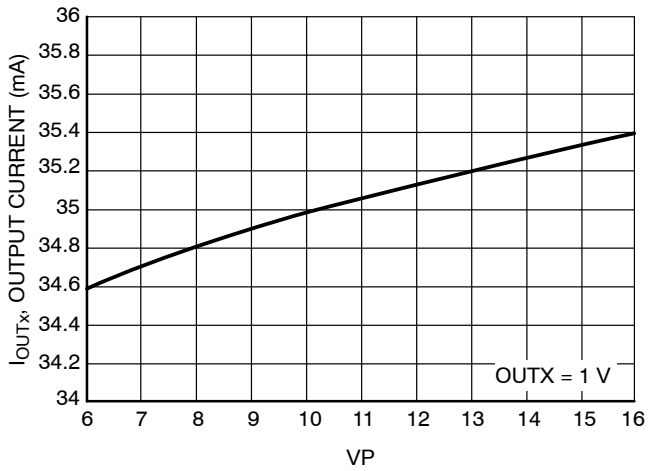

Figure 16. VP Line Regulation

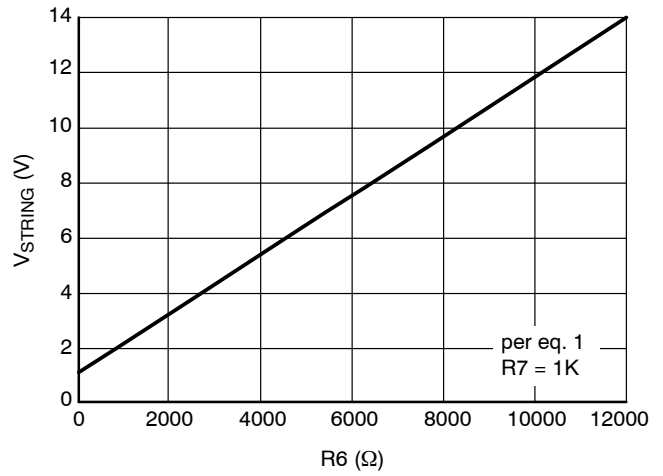

Figure 17. VSTRING vs. R6

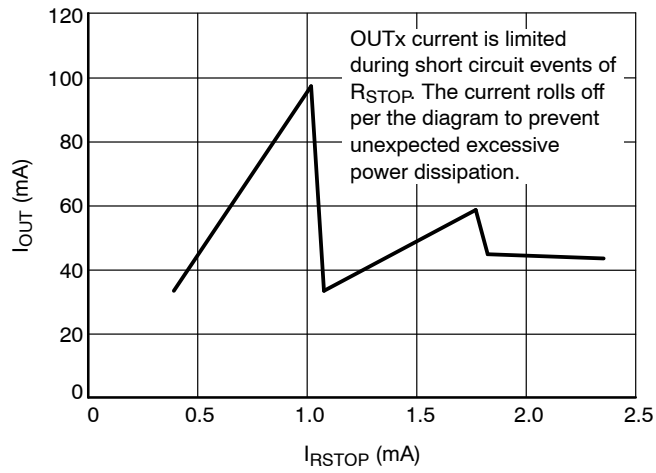

Figure 18. IOUT vs. I_RSTOP

DETAILED OPERATING DESCRIPTION

General

The NCV7680 consists of eight linear programmable constant current sources. The part is designed for use in the regulation and control of LED based Rear Combination Lamps for automotive applications. System design with the NCV7680 allows for two brightness levels; one for stop, and one for tail illumination.

Brightness levels are easily programmed (stop current absolute value, tail current duty cycle value) with two external resistors.

The use of an external FET allows for power distribution on designs requiring high currents. Additionally, set back power limit reduces the drive current during overvoltage conditions. Set back power limit is most useful for low current applications when no external FET is used.

The NCV7680 offers all of the built in protection normal to regulator systems, such as current limit, thermal limit, and provides an open load diagnostic that coincides with the STOP input signal.

Open String Reporting (DIAG)

Open string detection is reported on the DIAG pin as a high with STOP Input high, or a combination of STOP Input high and TAIL Input high. Reference Table 1 on page 5 for more details. Open circuit is sensed on each of the 8 outputs. The typical threshold voltage for detection is 0.4 V. Care must be taken not to breach this voltage level under normal operation, or a false open will be reported. Make sure worst case system design focuses on the voltage level on top of the LED string (top anode) (V_{STRING}) and includes the worst case LED voltage drop while considering temperature effects.

Input Voltage and Set Back Current

Automotive battery systems have wide variations in line supply voltage. Low dropout is a key attribute for providing consistent LED light output at low line voltage. Unlike adjustable regulator based constant current source schemes where the set point resistor resides in the load path, the NCV7680's set point resistor lies outside the LED load path, and aids in the low dropout capability.

Setback Current Limit is employed during high voltage. During a Setback Current Limit event, the drive current is

reduced resulting in lower power dissipation on the IC. This occurs during high battery voltage ($V_P > 16 V$). In this way the NCV7680 can operate in extreme conditions and still provide a controlled level of light output

The Overvoltage condition is reported on the DIAG Pin. Reference Figures 19 and 20 for Power Limiting Behavior.

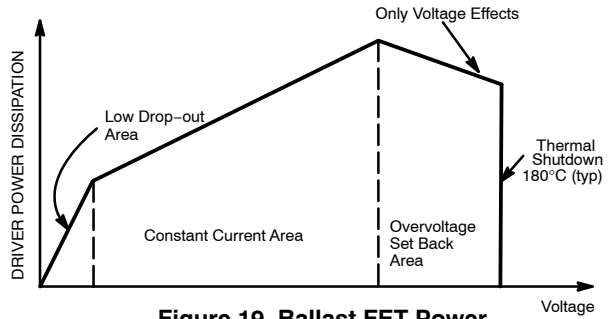

Figure 19. Ballast FET Power

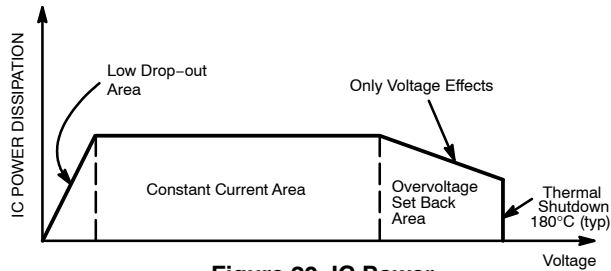

Figure 20. IC Power

Quiescent Current Power

Further reduction in power to the NCV7680 can be achieved by moving the V_P pin connection to the drain of the external FET. The contribution of power at the NCV7680 caused by the quiescent current into V_P is lowered due to the lower operating voltage of V_P with the new connection. Note also the addition of an external resistor R_{sd} in Figure 21. This will be required to insure startup of the system. A value for R_{sd} should be chosen low enough to provide current into V_P and the current in the I_{LEDs} & feedback string under all required input voltage input conditions. R_{sd} 's value should be chosen lower for slow rising V_{bat} signals to avoid switching between an Output Disable state and an Open Circuit state during power-up.

NCV7680

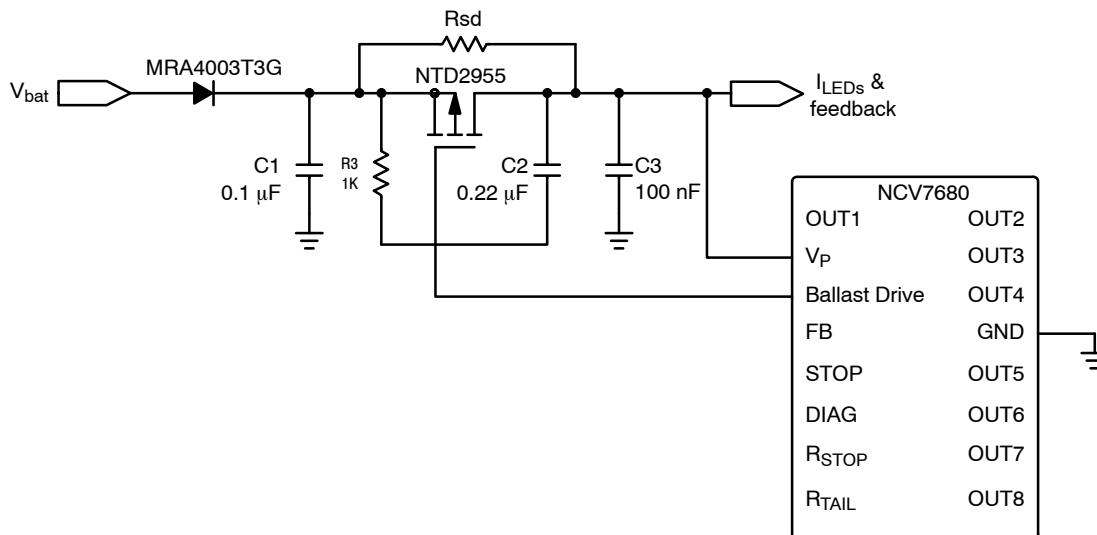

Figure 21. Alternative V_p Connection with R_{sd}

Programmability

Strings of LEDs are a common configuration for RCL applications. The NCV7680 provides eight matched outputs allowing individual string drive with current set by a single resistor. Individual string drive is a benefit to ensure equal current distribution amongst all of the strings. Output currents are mirrored and matched within $\pm 5\%$ at hot temperature.

A high STOP condition sets the output current using equation 1 below.

A low STOP condition, modulates the output currents at a duty cycle (DC) programmed using equation 2 below.

Note, current limiting on R_{STOP} limits the current which can be referenced from the RSTOP Pin. Exceeding the R_{STOP} Current Limit will reduce the output current and the DIAG Pin will go high (reference Figure 18). This helps limit output current (brightness and power) for this type of fault.

The average I_{STOP} Duty Cycle current provides the dimmed tail illumination function and assures a fixed brightness level for tail. The PWM generator's fixed frequency (1 kHz typ.) oscillator allows flicker-free illumination. PWM control is the preferred method for dimming LEDs.

The diagnostic function allows the detection of an open in any one of the output circuits. The active-low diagnostic output (DIAG) is coincident with the STOP input. DIAG remains high (pulled up) if an open load is detected in any LED string when STOP is high.

Output Current Programming

Reference Figure 10 to choose programming resistor (R_{STOP}) value for stop current. Reference Figure 12 (Duty Cycle vs. R_{TAIL}) to choose a typical value programming resistor for output duty cycle (with a typical R_{STOP} value of 3.09 k Ω). Note the duty cycle is dependent on both R_{STOP} and R_{TAIL} values. R_{STOP} should always be chosen first as the stop current is only dependent on this value.

Alternatively, the equations below can be used to calculate a typical value and used for worst case analysis.

Set the Stop Current using R_{STOP}

$$\text{OUTX} = 100 \times \frac{R_{\text{STOP_Bias_Voltage}}}{R_{\text{STOP}}} \quad (\text{eq. 1})$$

$$R_{\text{STOP_Bias_Voltage}} = 1.08 \text{ V (typ)}$$

Set the Duty Cycle (DC) using R_{TAIL}

$$R_{\text{TAIL}} = \left(\frac{4}{m}\right) \times R_{\text{STOP}}(\text{DC} + 0.1) \quad (\text{eq. 2})$$

DC = duty cycle expressed in fractional form.

(e.g. 0.50 is equivalent to 50% duty cycle)

$$m = 1.16 = \text{Mirror Coupling Ratio} = \frac{I_{\text{RTAIL}}}{I_{\text{RSTOP}}}$$

(ground R_{TAIL} when using external modulation)

Output Current is directly tested per the electrical parameter table to be $\pm 10\%$ (with R_{STOP} = 3.09 k Ω) or 31.5 mA (min), 35 mA (typ), 38.5 mA (max) at room and hot temperature.

Duty Cycle will vary according to the changes in R_{TAIL} Voltage and R_{TAIL} Bias Current (generated from the current through R_{STOP}).

Voltage errors encompass generator errors (0.4 V to 4.4 V) and comparator errors and are included in testing as the Duty Cycle. Typical duty cycle measurements are 5% with R_{TAIL} = 0.59 V and 70% with R_{TAIL} = 3.29 V.

R_{TAIL} Bias Current errors are measured as R_{TAIL} Bias Current and vary as 300 μA (min), 350 μA (typ), and 450 μA (max) with R_{STOP} = 3.09 k Ω .

The error duality and choice of duty cycle levels make it difficult to specify duty cycle minimum and maximum limits, but worst case conditions can be calculated when considering the variation in the voltage threshold and current source. Duty Cycle variation must include the direct duty cycle as specified in the electrical parameter table plus an additional error due to the I_{stop} current which generates this voltage in the system.

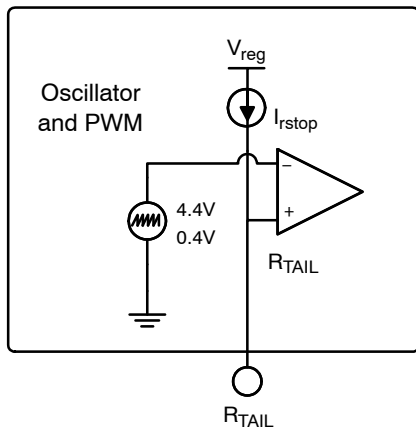

Figure 22. Duty Cycle Generator Circuitry

Alternative Setup of Duty Cycle

Alternatively, the duty cycle can be controlled by providing a voltage to the R_{TAIL} pin as per Figure 13 (Duty Cycle vs. V(R_{TAIL})). Note the pull-up current source (I_{rstop}) is still present on the R_{TAIL} pin due to current setting resistor connected to R_{STOP}. For proper operation the system designer needs to insure there is sufficient loading on the R_{TAIL} pin such that I_{rstop} does not pull the referenced voltage higher than its regulated state.

Setting V_{STRING}

V_{STRING} should be set to a level to allow proper operation of the IC without detecting an open circuit (0.5 V max on OUT_x) and to keep power to the IC at reduced levels below the 150°C max die temperature thermal limit (die temperature will depend on printed circuit board composition, PCB size, thermal via number and placement, module component placement, and air flow).

Example:

V_{STRING} is set using resistors R6 and R7 (reference Figure 4).

$$V_{STRING} = V_{FB} \left(\frac{R6}{R7} + 1 \right) \quad (\text{eq. 3})$$

V_{FB} = Ballast Drive Reference Voltage

This simplifies to an equation for R6.

$$R6 = \frac{R7(V_{STRING} - V_{FB})}{V_{FB}} \quad (\text{eq. 4})$$

Calculate system design V_{STRING}.

Let V_{LED} be the voltage drop across your LEDs (3 included in Figure 4). 9.5 V

Choose a value for OUT_x, 1 V

$$V_{STRING} = V_{OUTx} + V_{LED} \quad (\text{eq. 5})$$

Using Equation 3

$$V_{STRING} = 1 \text{ V} + 9.5 \text{ V} = 10.5 \text{ V}$$

Using Equation 4

Choose a value for R7.

R7 = 1k

$$R6 = \frac{1k(10.5 \text{ V} - 1.08 \text{ V})}{1.08 \text{ V}} = 8.72k$$

The closest standard resistor value is 8.87k.

Reduced Channel Operation

The previously shown applications (Figures 4 and 5) show system operation using all 8 available channels of the NCV7680. When less than 8 channels are used, the unused OUT_x pins can be grounded eliminating the unused OUT_x drive current. This is accomplished by voltage threshold detection on OUT_x (100 mV typ). A voltage less than 100 mV on OUT_x turns the driver off, reducing quiescent current to the IC. This also helps reduce system power by eliminating the need for an external pullup resistor (from OUT_x to V_p) while maintaining open circuit detection. External pullup resistors may be used as an alternative.

Adding LED's to the String

The NCV7680 can function as a standalone device or in conjunction with additional support circuitry for more complex systems. Figure 23 shows the NCV7680 operating with a boost controller. This setup allows additional LEDs in a string to be increased. Eight are shown in the diagram. Consideration of the 45 V maximum limit on the OUT_x Pin is the limitation of this configuration. The DC on voltage level on OUT_x must also be considered for thermal reasons.

Electromagnetic Interference (EMI)

One of the key contributors to electromagnetic interference is the rise and fall times of the electrical signals. This is a concern with both the initial startup of a device, and the repeated turn on/off cycles of a device.

The NCV7680 employs current slew rate control. Each output is rated at 6.0 mA/μs (typ). Slew rate control reduces overshoot and allows for a predictable electrical signal. Slew rate control is used in the stop mode for soft-start and in the tail mode for low EMI operation.

EMC susceptibility improvements to the NCV7680 device can be made by adding a ferrite bead directly on the VP (pin 2) of the device. The recommended component for this setup is the TDK PN/ MMZ2012S601A, FERRITE CHIP 600 OHM 500MA 0805 device. Care should be taken to add this component no less than 10mils from the pin.

An R-C network can also be used as an alternative to the ferrite bead. A 100 Ω resistor in series with VP (pin 2) with a 1nF – 10 nF very low ESR ceramic capacitor provides a similar roll-off. A very-low ESR ceramic capacitor is a requirement here. A normal ceramic capacitor will not suffice in this setup. The design should consider that the dropout voltage of the LED strings must be higher than the minimum operating voltage of the IC plus the voltage drop across the 100 Ω resistor.

NCV7680

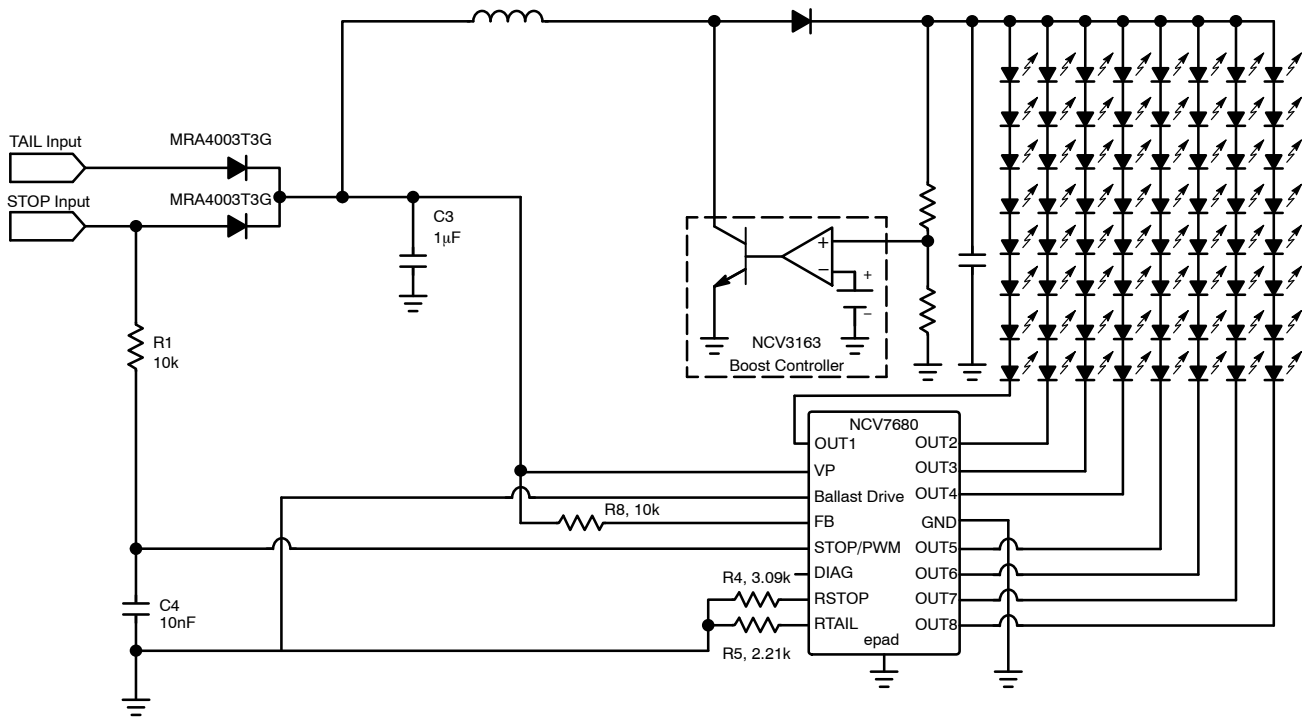
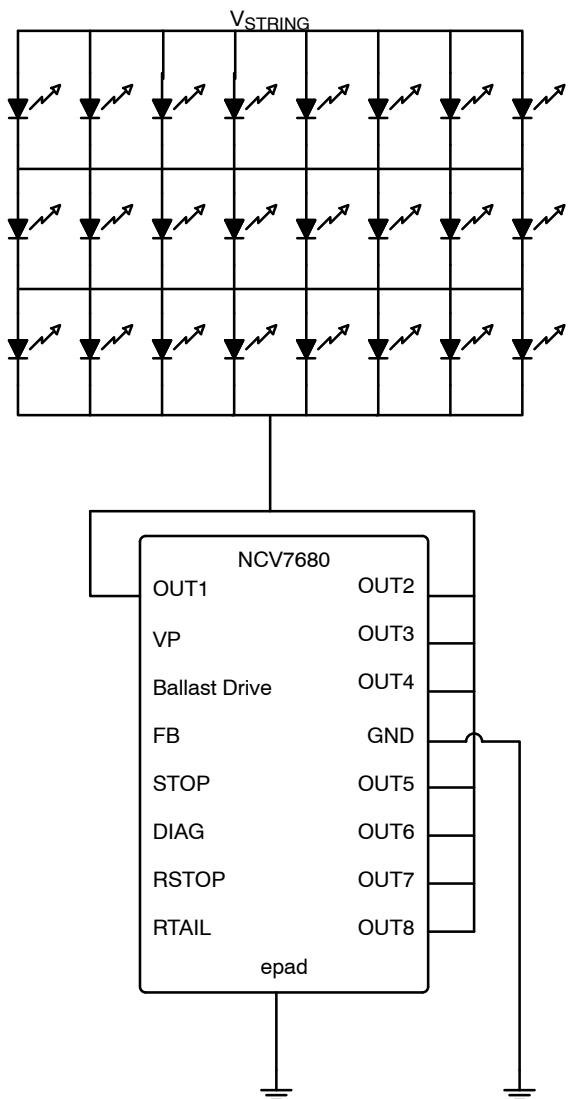

Figure 23. Boost Mode



Cross-Coupled LEDs

The setup in Figure 24 shows the LEDs set up in a cross-coupled configuration connected to all the outputs of the NCV7680 in parallel. This allows the user to maintain illumination of all the remaining LEDs when one fails due to an open circuit (the most common form of LED failure). Comparatively, the standard setup shown in Figure 4 will result in a full string turning off when one LED is open. Be aware as LEDs fail as open circuits in the cross-coupled arrangement will cause the row of LEDs to run at a higher current level affected by the smaller number of LEDs in that row.

Figure 24. Cross Coupled LEDs

NCV7680

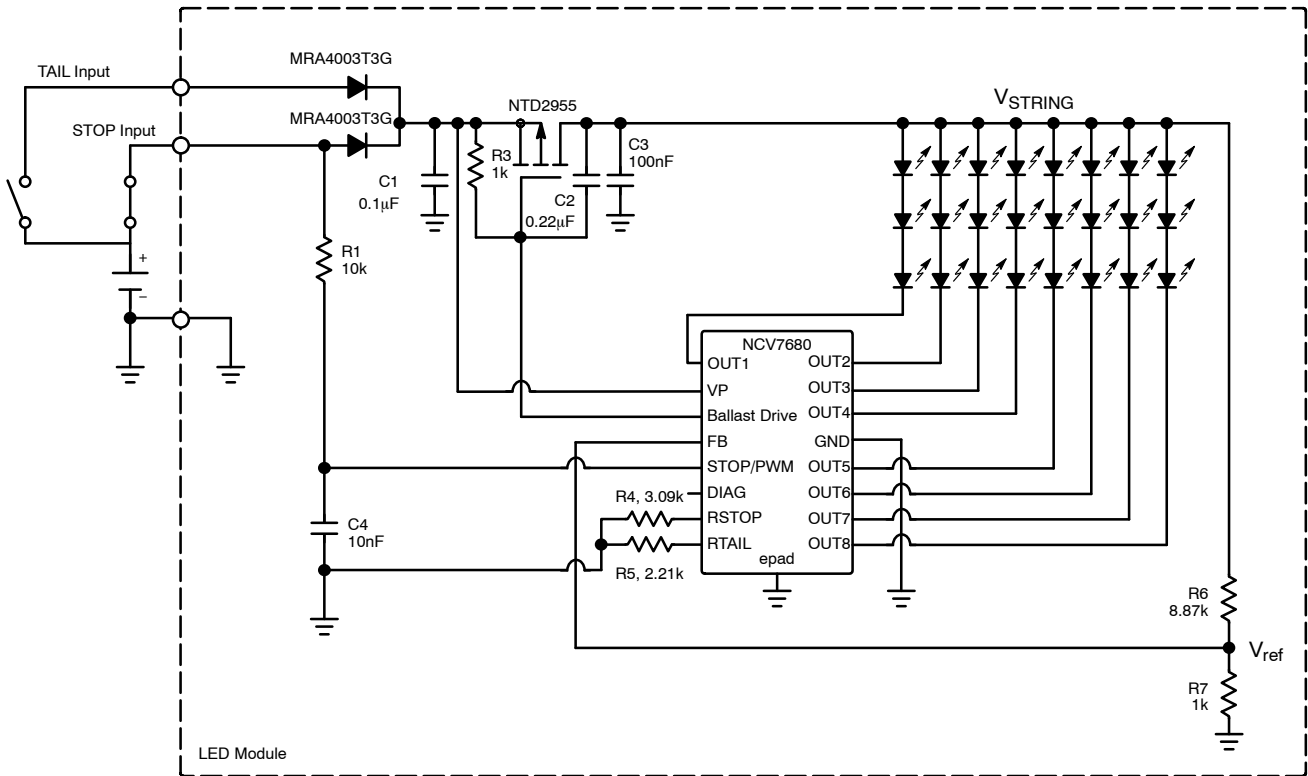

Figure 25. No Tail Light, Stop Illuminated

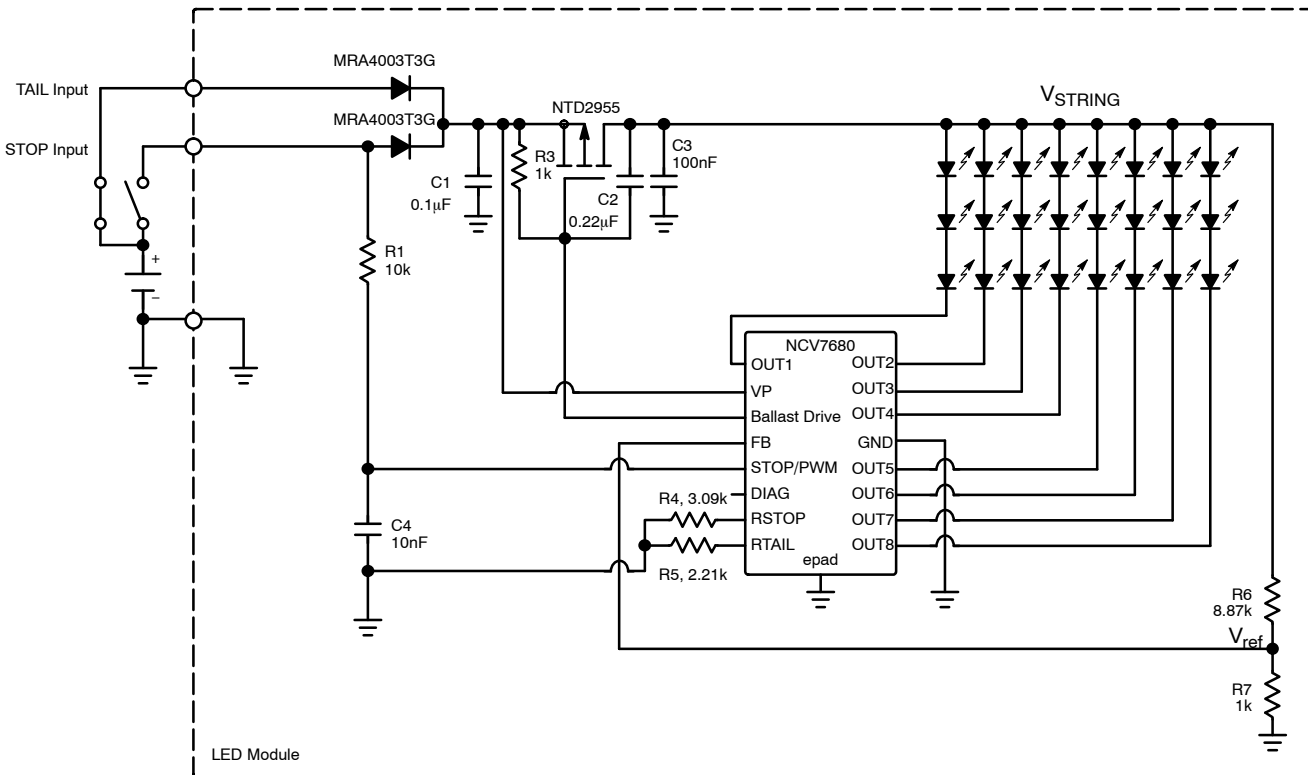

Figure 26. Tail Light Illuminated, No Stop

NCV7680

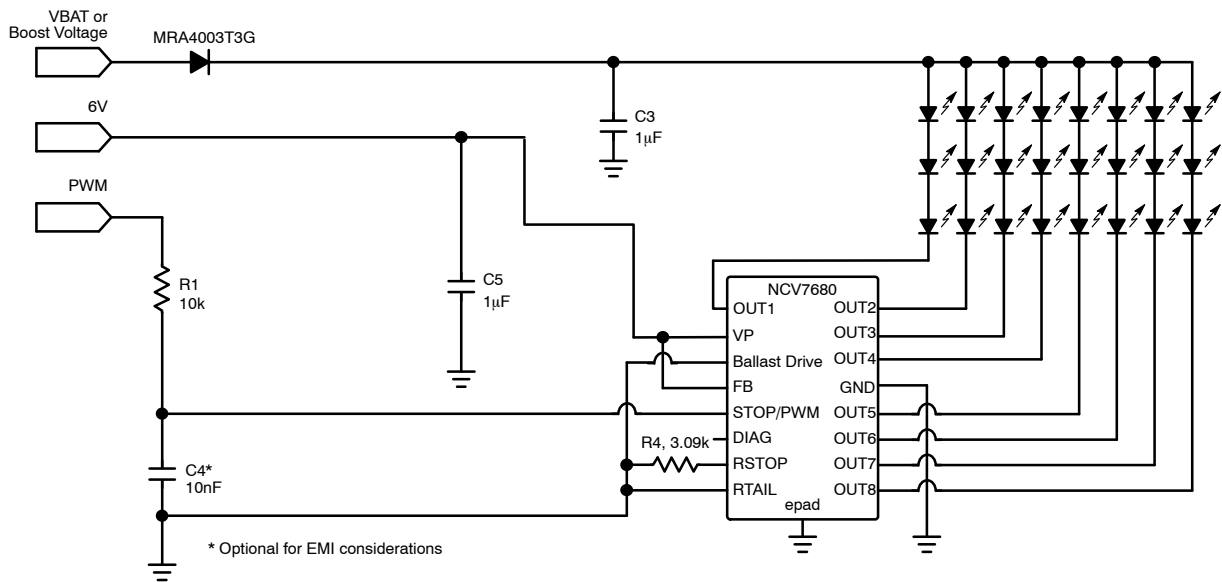

Figure 27. PWM Operation (suggested LCD backlighting applications)

External PWM Operation

Using the NCV7680 in a PWM setup requires R_{TAIL} to be grounded. Grounding R_{TAIL} disables the internal PWM circuitry. With R_{TAIL} grounded, the STOP input pin can then be modulated externally with a microprocessor using the STOP logic input level thresholds.

Tail Frequency Stabilization Time requires 2 pulses from the internal oscillator. This is typically 2 ms (from the 1 kHz oscillator).

Circuit limitations dictate the maximum output current (I_{OUTX}) to be 60 mA when operated at $V_P = 5$ V. Part capability increases up to the part maximum capability as V_P is increased.

Latch-Off on Open String Detection

Some LED lighting systems require the complete lighting system to shut down when the output intensity has diminished. This eliminates a slow degradation of output illumination. Figure 28 provides one solution for this requirement. The open circuit fault information provided on

the DIAG pin coupled with external discrete transistors provides the feedback needed to the FB pin to turn off the ballast transistor drive removing the LED anode string from any power source. This condition is held until the input signal is toggled.

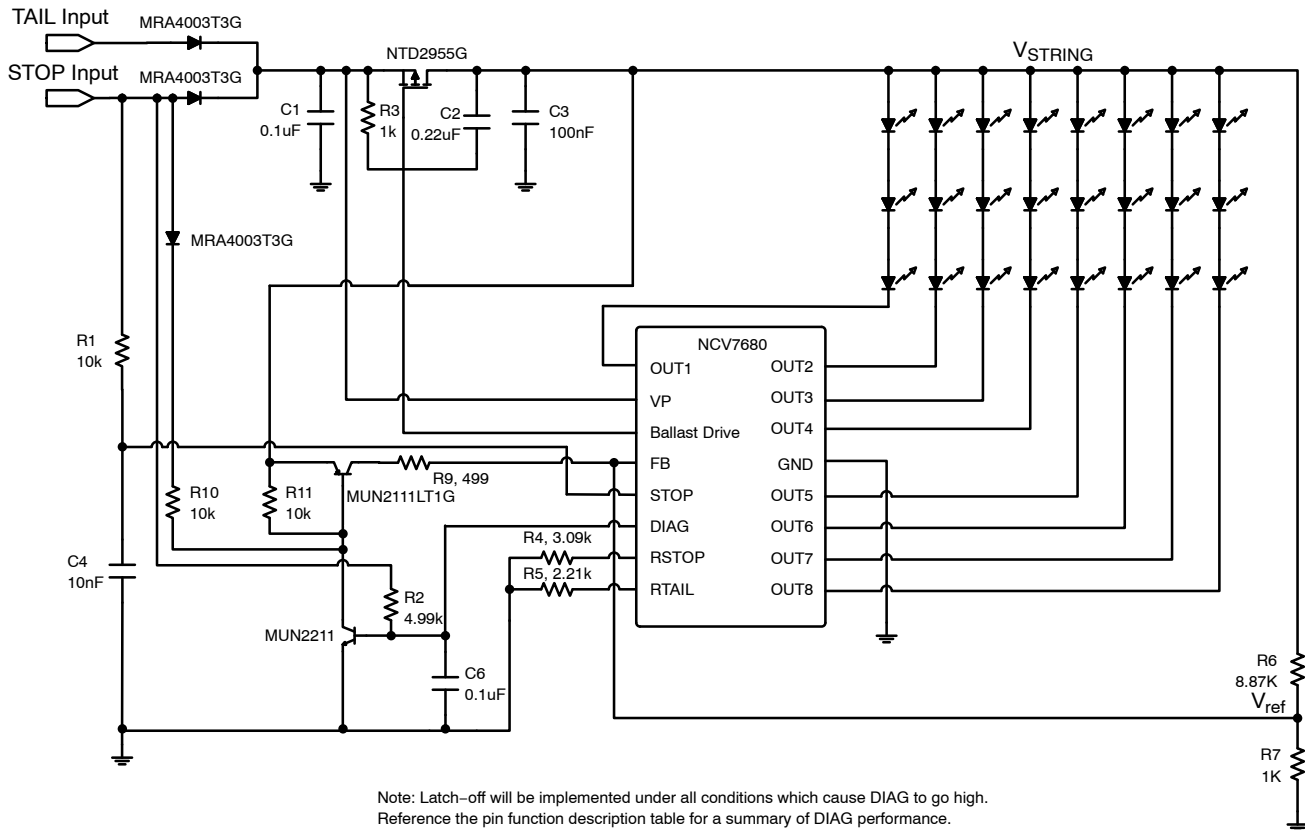

Note: Latch-off will be implemented under all conditions which cause DIAG to go high. Reference the pin function description table for a summary of DIAG performance.

Figure 28. Latch-Off Circuit

Checking DIAG After Assembly

Production requirements often require the functional testing of all parameters in a system. This can be a difficult parameter to check if the function is exercising the DIAG pin. You cannot easily create an open circuit condition to check on the reporting capability of the DIAG pin. This would require you to remove one or all LEDs in a string.

As an alternative you can use the Set Back Current Limit function of the device. Increasing the voltage to the VP pin (STOP mode) will cause the current through the LEDs to decrease. Because DIAG also reports when the current limit has decreased 20%, we can calculate the minimum voltage needed to create that condition.

The Voltage Fold-Back equation is:

$$VP@(x\% \text{ reduction}) = \left(\frac{x\% \text{ reduction}}{kv} \right) + VP(1\% \text{ reduction}) \quad (\text{eq. 6})$$

Where kv= %/V

Using the electrical parameters in the datasheet, we have: (x% reduction)=20, kv=4%min(@20% reduction), VP(1% reduction)max=24.5V.

$$VP(@20\% \text{ reduction}) \text{ max} = \left(\frac{20}{4} \right) V + 24.5 V = 29.5 V \quad (\text{eq. 7})$$

This is the maximum worst case voltage the NCV7680 will toggle the DIAG pin at VP. An additional increase in voltage should be used for good engineering judgment here. A supply voltage of 32V is recommended. Note the maximum capability of the VP and DIAG pins is 45V.

An alternative to supplying the higher voltage on VP to toggle DIAG requires the short the Rstop pin to ground (must be less than 0.5V).

Note the Rstop pin is self-protected as per Figure 18 Iout vs. Irstop.

NCV7680

PACKAGE DIMENSIONS

SOIC 16 LEAD WIDE BODY, EXPOSED PAD CASE 751AG-01 ISSUE A

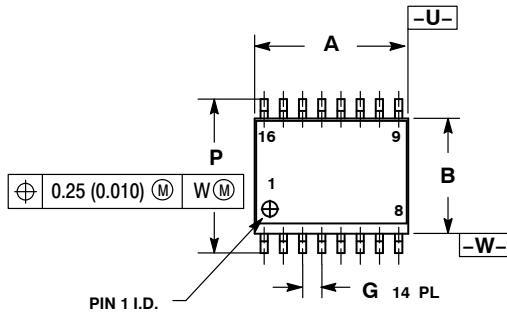

TOP SIDE

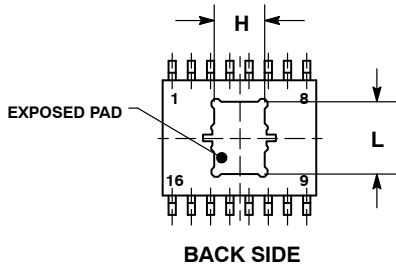
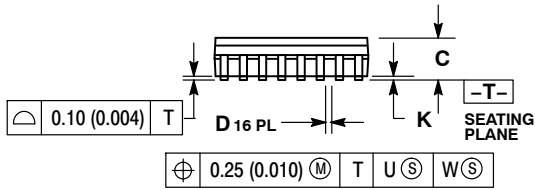

BACK SIDE

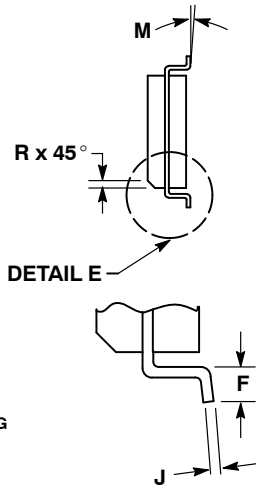

DETAIL E

NOTES:

1. DIMENSIONING AND TOLERANCING PER ANSI Y14.5M, 1982.
2. CONTROLLING DIMENSION: MILLIMETER.
3. DIMENSION A AND B DO NOT INCLUDE MOLD PROTRUSION.
4. MAXIMUM MOLD PROTRUSION 0.15 (0.006) PER SIDE.
5. DIMENSION D DOES NOT INCLUDE DAMBAR PROTRUSION. ALLOWABLE PROTRUSION SHALL BE 0.13 (0.005) TOTAL IN EXCESS OF THE D DIMENSION AT MAXIMUM MATERIAL CONDITION.
6. 751R-01 OBSOLETE, NEW STANDARD 751R-02.

DIM	MILLIMETERS		INCHES	
	MIN	MAX	MIN	MAX
A	10.15	10.45	0.400	0.411
B	7.40	7.60	0.292	0.299
C	2.35	2.65	0.093	0.104
D	0.35	0.49	0.014	0.019
F	0.50	0.90	0.020	0.035
G	1.27 BSC		0.050 BSC	
H	3.45	3.66	0.136	0.144
J	0.25	0.32	0.010	0.012
K	0.00	0.10	0.000	0.004
L	4.72	4.93	0.186	0.194
M	0°	7°	0°	7°
P	10.05	10.55	0.395	0.415
R	0.25	0.75	0.010	0.029

SOLDERING FOOTPRINT*

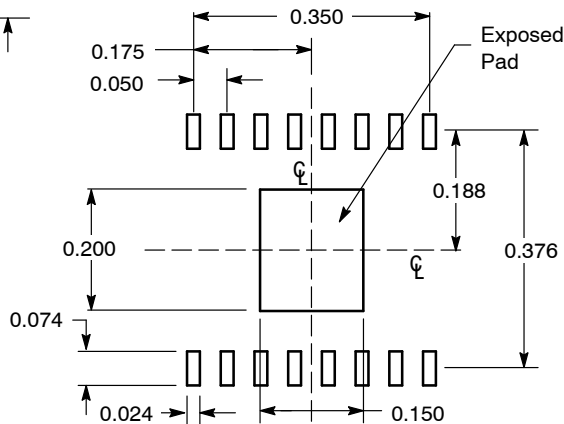

DIMENSIONS: INCHES

*For additional information on our Pb-Free strategy and soldering details, please download the ON Semiconductor Soldering and Mounting Techniques Reference Manual, SOLDERRM/D.

ON Semiconductor and are registered trademarks of Semiconductor Components Industries, LLC (SCILLC). SCILLC reserves the right to make changes without further notice to any products herein. SCILLC makes no warranty, representation or guarantee regarding the suitability of its products for any particular purpose, nor does SCILLC assume any liability arising out of the application or use of any product or circuit, and specifically disclaims any and all liability, including without limitation special, consequential or incidental damages. "Typical" parameters which may be provided in SCILLC data sheets and/or specifications can and do vary in different applications and actual performance may vary over time. All operating parameters, including "Typicals" must be validated for each customer application by customer's technical experts. SCILLC does not convey any license under its patent rights nor the rights of others. SCILLC products are not designed, intended, or authorized for use as components in systems intended for surgical implant into the body, or other applications intended to support or sustain life, or for any other application in which the failure of the SCILLC product could create a situation where personal injury or death may occur. Should Buyer purchase or use SCILLC products for any such unintended or unauthorized application, Buyer shall indemnify and hold SCILLC and its officers, employees, subsidiaries, affiliates, and distributors harmless against all claims, costs, damages, and expenses, and reasonable attorney fees arising out of, directly or indirectly, any claim of personal injury or death associated with such unintended or unauthorized use, even if such claim alleges that SCILLC was negligent regarding the design or manufacture of the part. SCILLC is an Equal Opportunity/Affirmative Action Employer. This literature is subject to all applicable copyright laws and is not for resale in any manner.

PUBLICATION ORDERING INFORMATION

LITERATURE FULFILLMENT:
Literature Distribution Center for ON Semiconductor
P.O. Box 5163, Denver, Colorado 80217 USA
Phone: 303-675-2175 or 800-344-3860 Toll Free USA/Canada
Fax: 303-675-2176 or 800-344-3867 Toll Free USA/Canada
Email: orderlit@onsemi.com

N. American Technical Support: 800-282-9855 Toll Free USA/Canada
Europe, Middle East and Africa Technical Support:
Phone: 421 33 790 2910
Japan Customer Focus Center
Phone: 81-3-5817-1050

ON Semiconductor Website: www.onsemi.com
Order Literature: <http://www.onsemi.com/orderlit>
For additional information, please contact your local Sales Representative