



Chipsmall Limited consists of a professional team with an average of over 10 year of expertise in the distribution of electronic components. Based in Hongkong, we have already established firm and mutual-benefit business relationships with customers from,Europe,America and south Asia,supplying obsolete and hard-to-find components to meet their specific needs.

With the principle of "Quality Parts,Customers Priority,Honest Operation,and Considerate Service",our business mainly focus on the distribution of electronic components. Line cards we deal with include Microchip,ALPS,ROHM,Xilinx,Pulse,ON,Everlight and Freescale. Main products comprise IC,Modules,Potentiometer,IC Socket,Relay,Connector.Our parts cover such applications as commercial,industrial, and automotives areas.

We are looking forward to setting up business relationship with you and hope to provide you with the best service and solution. Let us make a better world for our industry!



## Contact us

Tel: +86-755-8981 8866 Fax: +86-755-8427 6832

Email & Skype: info@chipsmall.com Web: www.chipsmall.com

Address: A1208, Overseas Decoration Building, #122 Zhenhua RD., Futian, Shenzhen, China



# NCV7681AGEVB

## NCV7681AGEVB Evaluation Board User's Manual

### Eight (8) Channel Enhanced 100 mA Linear Current Regulator and Controller for Automotive LED Lighting Evaluation Board User's Manual

#### Description

The NCV7681A is an octal LED driver designed for automotive LED car rear combination lamps. External programmability of the NCV7681A allows the user to set the tail current and stop currents using a single resistor for each function.

The NCV7681A does NOT have a one-out all-out function. A one-out all-out function disables all strings when an open circuit occurs on one string.

Systems requiring one-out all-out have the option of using the NCV7681L.

The two typical control inputs into the system are available through on-board switches or through the pin connections to external controls. The two system control inputs are the STOP and TAIL functions. The STOP function displays a 100% duty cycle current through the LEDs. The TAIL function displays a programmable PWM current through the LEDs.

#### Features

- STOP, TAIL (100% Duty Cycle, PWM) Modes
- Flexibility for
  - ◆ External LED Connections
  - ◆ LED Current Programmability (RSTOP)
  - ◆ LED PWM Programmability (RTAIL)
  - ◆ STOP, TAIL External Connections
  - ◆ External DIAG Pin Connection

#### Application

The NCV7681A features the ability to drive 8 individual strings of LEDs (reference Figure 2) with a programmed current for a DC current for STOP mode and a PWM current for TAIL model. These are programmed using resistors to ground on the RSTOP and RTAIL pins. Control of the STOP and TAIL functions use an external network of diodes with the STOP pin. LED open string reporting is reported on the DIAG pin. The DIAG pin also serves to reset a latched off event. System power distribution is accomplished using voltage feedback on the top LED anode programming a set voltage in the system to allow a split between the IC and the ballast transistor.



ON Semiconductor®

[www.onsemi.com](http://www.onsemi.com)

### EVAL BOARD USER'S MANUAL



TAIL Mode



STOP Mode

Figure 1. Evaluation Board Picture

# NCV7681AGEVB

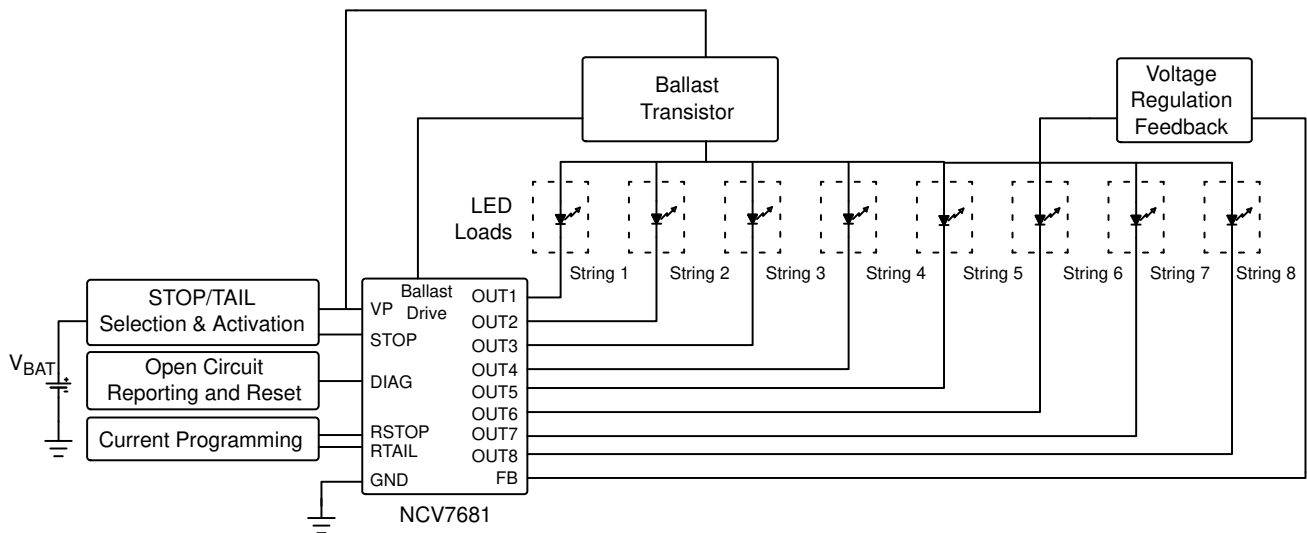

**Figure 2. Focus Demonstration**

## STOP

The STOP function displays the highest system output current at 100% duty cycle. Using the STOP switch activates this function. The current is programmable with a resistor on the RSTOP pin to ground. Jumper J3 provides isolation of pin 7 of the NCV7681 allowing access to the pin for alternative selection of output current. The range of programmability is from 15 mA to 100 mA using the equation:

$$I_{OUT} = \frac{150}{R_{STOP}}$$

where  $R_{STOP}$  is the resistor value.

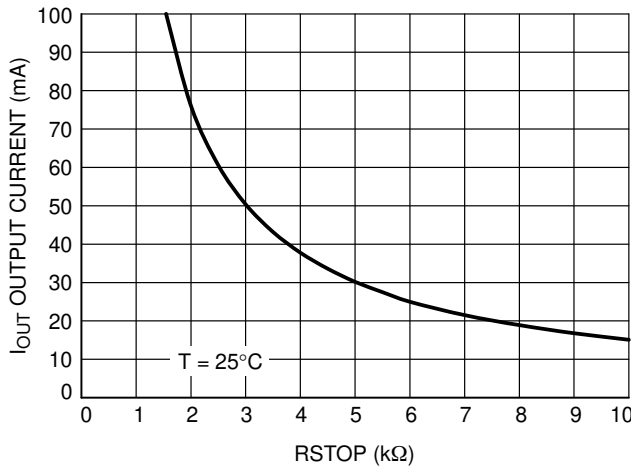

**Figure 3. I<sub>OUT</sub> vs. R<sub>STOP</sub>**

## TAIL

The TAIL function displays a lower equivalent output current in the system. This provides a lower illumination of the LEDs. This is achieved with a varied duty cycle of the output current. The duty cycle is programmable with a resistor on the RTAIL pin to ground. Jumper J4 provides isolation of pin 6 of the NCV7681A allowing access to the pin for alternative selection of output duty cycle current. The range of programmability is from 0% duty cycle to 100% duty cycle using the equation:

$$RTAIL = 1.8 \times R_{STOP} (DC + 0.22)$$

where DC = duty cycle expressed in fractional form.

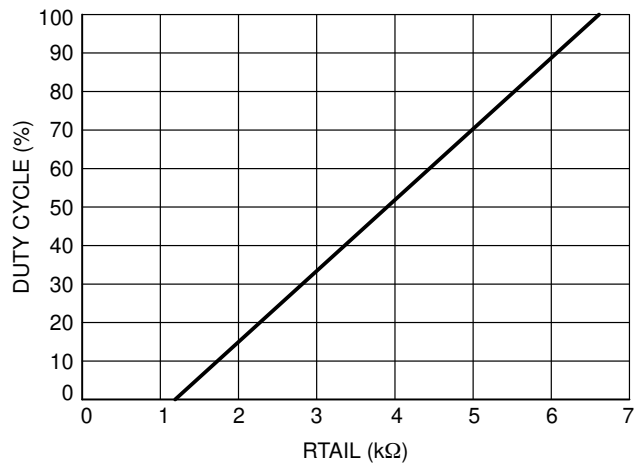

**Figure 4. Duty Cycle vs. R<sub>TAIL</sub>**

# NCV7681AGEVB

## DIAG

The DIAG pin of the NCV7681A provides system feedback for conditions:

1. Output open circuit.
2. Set Back Current Limit down 20%.
3. Thermal shutdown.
4. RSTOP Current Limit.

An LED indicator with a current setting resistor provides illumination of these conditions. Jumper J5 provides access to these pins for the user to use off-board.

## External LEDs

The NCV7681AGEVB is compatible for use with external LEDs.

To use external LEDs,

1. Remove J14 or J18 depending on your setup
2. Replace with the Anode of your external LED string (connect to the post on the right).
3. If needed, connect the post on the left also with the anode of your external LED string.

4. Remove your selection of J6–J13 (OUT<sub>x,y</sub>).
5. Connect the Cathode of your external LED string (connect to the post on the right).

The operation of the NCV7681A evaluation board works as a standalone presentation for the customer. Jumpers are provided for flexibility of customer specific designs with external LEDs and programming of the current and duty cycle. External control points are also provided in addition to the on-board control switches. The user must adhere to the absolute maximum ratings when using off-board connections.

Note the inclusion of the Open Load Disable Threshold in the NCV7681A device. This is included to avoid false open load detection at low supply voltages due to headroom issues with external LEDs. Operation of LED drive current is valid above the Output Under Voltage Lockout threshold ( $V_P = 4.1\text{ V}$  [typ]), allowing for illumination down to that voltage, but open load detection is only valid above  $V_P = 7.7\text{ V}$  [typ].

**Table 1. ABSOLUTE MAXIMUM RATINGS**

Rating	Value	Unit
Supply Voltage to board ( $V_{BAT}$ )	-40 to 40	V
STOP, TAIL	-40 to 40	V
LED Current Source (OUT1–OUT8)	200	mA
Output Pin Voltage (OUT1–OUT8)	-0.3 to 40	V
Output Pin Voltage (RTAIL, RSTOP)	-0.3 to 3.6	V
DIAG	-0.3 to 40	V
$V_{STRING}$	-0.3 to 40	V
Junction Temperature (NCV7681A)	-40 to 150	°C
Junction Temperature (Evaluation Board)	-40 to 105	°C

Stresses exceeding those listed in the Maximum Ratings table may damage the device. If any of these limits are exceeded, device functionality should not be assumed, damage may occur and reliability may be affected.

**Table 2. RECOMMENDED BOARD OPERATING CONDITIONS**

Rating	Value		Unit
	Min	Max	
External Supply Voltage ( $V_{BAT}$ )	-	28	V
LED Current Source	-	200	mA
Junction Temperature (NCV7681A)	-40	150	°C

Functional operation above the stresses listed in the Recommended Operating Ranges is not implied. Extended exposure to stresses beyond the Recommended Operating Ranges limits may affect device reliability.

# NCV7681AGEVB

**Table 3. PIN FUNCTION DESCRIPTION**

Connector	Pin Number	Terminal Name	Description
Power	J1, V <sub>BAT</sub>	V <sub>BAT</sub>	Power Supply Input Voltage (14 V)
	J2, GND	GND	Ground
	J3	RSTOP	Programmable DC Current
	J4	RTAIL	Programmable Duty Cycle
	J5	DIAG	DIAG Open Drain Output
	J6	OUT1	Current Outputs
	J7	OUT2	
	J8	OUT3	
	J9	OUT4	
	J10	OUT5	
	J11	OUT6	
	J12	OUT7	
	J13	OUT8	
	J14	BALLAST IN	Connect when Using External Ballast Transistor. Connects Drain of External Ballast Transistor to V <sub>STRING</sub> .
	J15	J15	Connection to Top of the FB Resistor Network or Open Circuit
	J16	J16	Connection to Short FB Pin to Ground or Open Circuit
J17	J17	Connection for Ballast Drive Gate Pin to Ballast Gate or to Ground	
J18	BALLAST OUT	Connect when Not Using External Ballast Transistor. Shorts S-D of External Transistor.	

## User Interface Locations

Figure 5 shows all the user interface locations.

This lists all the user options available on the evaluation board.

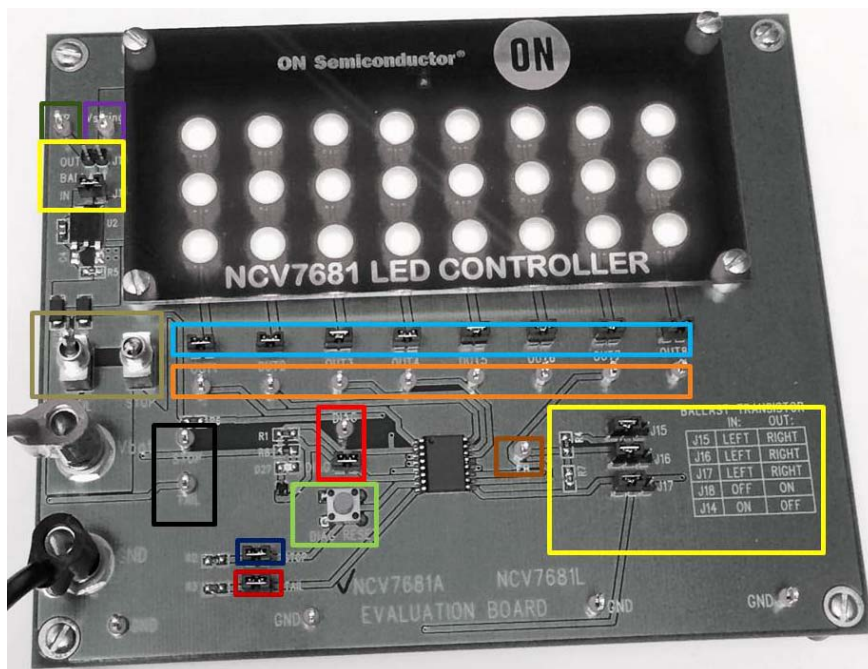

**Figure 5. User Interface Locations**

**Black** – STOP, TAIL external connections.

**Grey** – STOP, TAIL switches.

**Dark Blue (2)** – STOP programming jumper.

**Red (2)** – TAIL programming jumper + post.

**Dark Green** – VP post.

**Purple (2)** – V<sub>STRING</sub> post.

**Light Blue (4)** – OUT1–OUT8 open circuit jumpers.

**Orange** – OUT1–OUT8 output posts.

**Yellow** – Ballast Transistor Selection (2 yellow boxes).

**Light Green** – DIAG RESET.  
(Not functional in the NCV7681A)  
(Only functional in the NCV7681L)

**Bright Red** – DIAG jumper / post.

**Brown** – Feedback post (FB).

# NCV7681AGEVB

## OPERATIONAL GUIDELINES

The material necessary to successfully use the evaluation board is listed below.

- NCV7683 Evaluation Board
- 14 V Power Supply Capable of drive 1 A.

### Configure the Board

#### Typical Board Configuration with On-Board Components

1. Connect all jumpers on the board with the exception of Jumper 18. J15–J17 should be to the left.
2. Connect the 14 V power supply.
3. Turn on the power supply.

#### Increasing the LED Current

Change the current programming resistor.  
Reference the STOP section.

#### Change the Duty Cycle

Change the duty cycle programming resistor.  
Reference the TAIL section.

#### DIAG

The on-board LED will illuminate when DIAG reports a fault.

Reporting can be taken off-board after removing the DIAG jumper (J5).

#### Use External LEDs

Reference the External LEDs section for instructions.

## SCHEMATIC

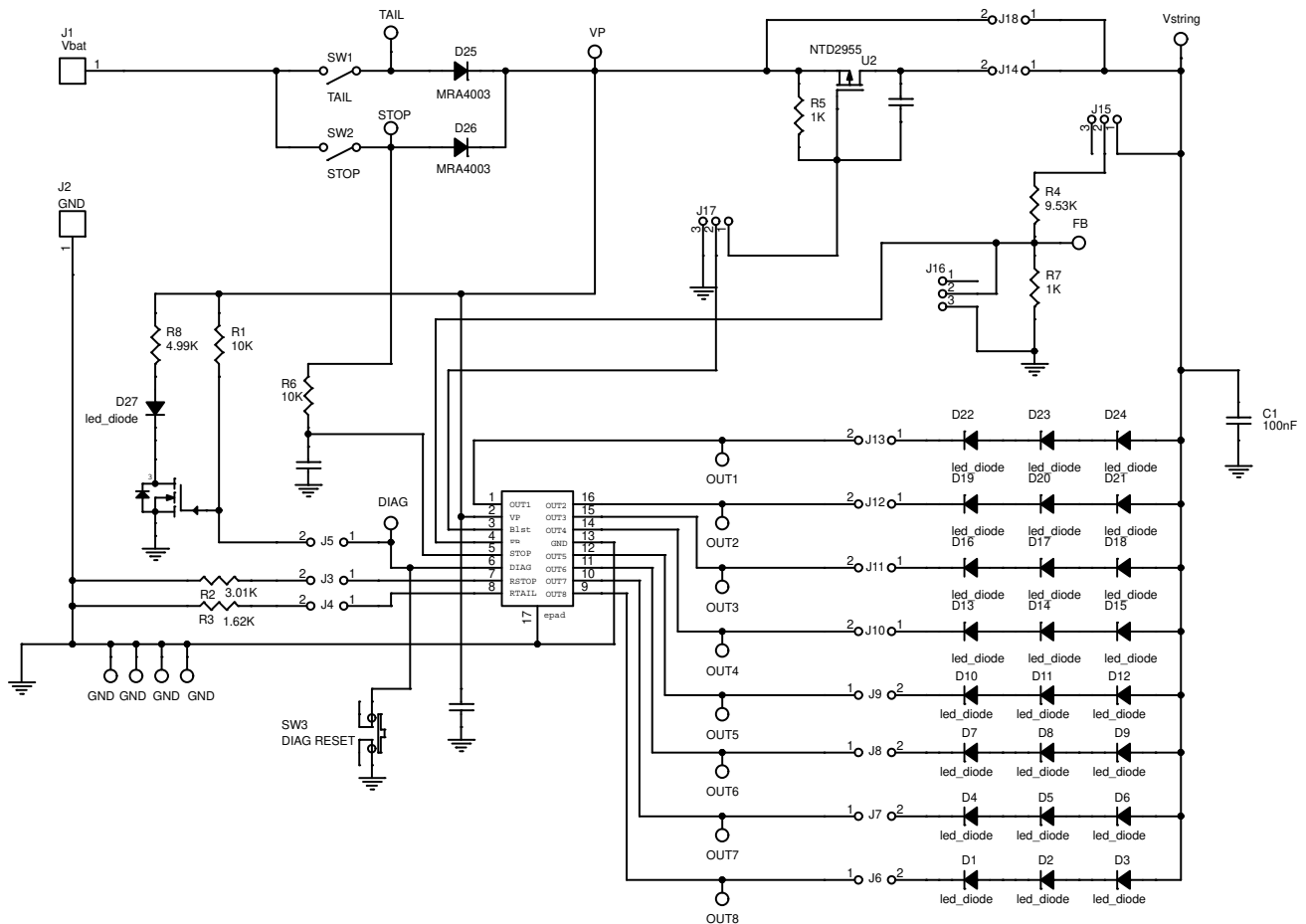

Figure 6. Evaluation Board Schematic

# NCV7681AGEVB

## BILL OF MATERIALS

**Table 4. NCV7681A LATCH OFF EVALUATION BOARD BILL OF MATERIALS**

Designator	Qty	Description	Value	Tolerance	Footprint	Manufacturer	Manufacturer Part Number	Substitution Allowed
C1	1	LED Storage Capacitor	100 nF	10%	0805	KEMET	C0805C104K5RACTU	Yes
C2	1	Debounce Capacitor	10 nF	10%	0805	KEMET	C0805C103K5RACTU	Yes
C3	1	Input Capacitor	0.68 $\mu$ F	10%	0805	KEMET	C0805C684K5RACTU	Yes
C4	1	Loop Stabilization Capacitor	0.22 $\mu$ F	10%	0805	KEMET	C0805C224K5RACTU	Yes
D1–D24	24	Display LEDs	led_diode	–	G6SP	OSRAM	LRG6SP–CADB–1–1	Yes
D25–D26	2	Steering Diode	MRA4003	–	SMA_DIODE	ON SEMICONDUCTOR	MRA4003T3G	Yes
D27	1	DIAG Reporting LED	led_diode	–	0805	LITE–ON INC	LTST–C171GKT	Yes
J3–J14, J18	13	Dual Jumper Posts 100 mil spacing	JUMPER	–	JMP	3M	961102–6404–AR	Yes
J15–J17	3	Triple Jumper Posts 100 mil spacing	JUMPER	–	JMP	3M	961102–6404–AR	Yes
J3–J18	16	Jumper	–	–	N/A	SULLINS CONNECTOR SOLUTIONS	QPC02SXGN–RC	Yes
J1	1	Banana Jack	V <sub>BAT</sub>	–	BANANA	CINCH CONNECTIVITY SOLUTIONS	108–0740–001	Yes
J2	1	Banana Jack	GND	–	BANANA	CINCH CONNECTIVITY SOLUTIONS	108–0740–001	Yes
Q2	1	DIAG Illumination Transistor Switch	2N7002W	–	SOT23M4	ON SEMICONDUCTOR	ONC 2N7002WT1G/BKN	Yes
R1, R6	2	Logic Resistors	10 k $\Omega$	1%	0805	VISHAY DALE	CRCW080510K0FKEA	Yes
R2	1	RSTOP Program Resistor	3.01 k $\Omega$	1%	0805	VISHAY DALE	CRCW08053K01FKEA	Yes
R3	1	RTAIL Program Resistor	1.62 k $\Omega$	1%	0805	VISHAY DALE	CRCW08051K62FKEA	Yes
R4	1	Vstring Program Resistor	9.53 k $\Omega$	1%	0805	VISHAY DALE	CRCW08059K53FKEA	Yes
R5	1	Gate–source Resistor	1 k $\Omega$	1%	0805	VISHAY DALE	CRCW08051K00FKEA	Yes
R7	1	Vstring Program Resistor	1 k $\Omega$	1%	0805	VISHAY DALE	CRCW08051K00FKEA	Yes
R8	1	DIAG LED Current Setting Resistor	4.99 k $\Omega$	1%	0805	VISHAY DALE	CRCW08054K99FKEA	Yes
SW1, SW2	2	User Interface Switches	–	–	MINITOGGLE	C & K COMPONENTS	T101MH9CBE	Yes
SW3	1	SPST–NO 0.05A 24V Tactile Switch	–	–	6x6	TE Connectivity Alcoswitch	1–1825910–0	Yes
TP1–TP18, TAIL	18	Test Inputs	–	–	TP	KEYSTONE ELECTRONICS	5010	Yes
U1	1	NCV7681A (SOIC–16WB epad)	–	–	16WEPAD	ON SEMICONDUCTOR	NCV7681APWR2G	No
U2	1	NVD2955	–	–	DPAK3_SMD	ON SEMICONDUCTOR	NVD2955T4G	No

# NCV7681AGEVB

ON Semiconductor and the  are registered trademarks of Semiconductor Components Industries, LLC (SCILLC) or its subsidiaries in the United States and/or other countries. SCILLC owns the rights to a number of patents, trademarks, copyrights, trade secrets, and other intellectual property. A listing of SCILLC's product/patent coverage may be accessed at [www.onsemi.com/site/pdf/Patent-Marking.pdf](http://www.onsemi.com/site/pdf/Patent-Marking.pdf). SCILLC reserves the right to make changes without further notice to any products herein. SCILLC makes no warranty, representation or guarantee regarding the suitability of its products for any particular purpose, nor does SCILLC assume any liability arising out of the application or use of any product or circuit, and specifically disclaims any and all liability, including without limitation special, consequential or incidental damages. "Typical" parameters which may be provided in SCILLC data sheets and/or specifications can and do vary in different applications and actual performance may vary over time. All operating parameters, including "Typicals" must be validated for each customer application by customer's technical experts. SCILLC does not convey any license under its patent rights nor the rights of others. SCILLC products are not designed, intended, or authorized for use as components in systems intended for surgical implant into the body, or other applications intended to support or sustain life, or for any other application in which the failure of the SCILLC product could create a situation where personal injury or death may occur. Should Buyer purchase or use SCILLC products for any such unintended or unauthorized application, Buyer shall indemnify and hold SCILLC and its officers, employees, subsidiaries, affiliates, and distributors harmless against all claims, costs, damages, and expenses, and reasonable attorney fees arising out of, directly or indirectly, any claim of personal injury or death associated with such unintended or unauthorized use, even if such claim alleges that SCILLC was negligent regarding the design or manufacture of the part. SCILLC is an Equal Opportunity/Affirmative Action Employer. This literature is subject to all applicable copyright laws and is not for resale in any manner.

## PUBLICATION ORDERING INFORMATION

### LITERATURE FULFILLMENT:

Literature Distribution Center for ON Semiconductor  
19521 E. 32nd Pkwy, Aurora, Colorado 80011 USA  
**Phone:** 303-675-2175 or 800-344-3860 Toll Free USA/Canada  
**Fax:** 303-675-2176 or 800-344-3867 Toll Free USA/Canada  
**Email:** [orderlit@onsemi.com](mailto:orderlit@onsemi.com)

**N. American Technical Support:** 800-282-9855 Toll Free  
USA/Canada  
**Europe, Middle East and Africa Technical Support:**  
Phone: 421 33 790 2910  
**Japan Customer Focus Center**  
Phone: 81-3-5817-1050

**ON Semiconductor Website:** [www.onsemi.com](http://www.onsemi.com)

**Order Literature:** <http://www.onsemi.com/orderlit>

For additional information, please contact your local  
Sales Representative

**EVBUM2328/D**