



Chipsmall Limited consists of a professional team with an average of over 10 year of expertise in the distribution of electronic components. Based in Hongkong, we have already established firm and mutual-benefit business relationships with customers from,Europe,America and south Asia,supplying obsolete and hard-to-find components to meet their specific needs.

With the principle of “Quality Parts,Customers Priority,Honest Operation,and Considerate Service”,our business mainly focus on the distribution of electronic components. Line cards we deal with include Microchip,ALPS,ROHM,Xilinx,Pulse,ON,Everlight and Freescale. Main products comprise IC,Modules,Potentiometer,IC Socket,Relay,Connector.Our parts cover such applications as commercial,industrial, and automotives areas.

We are looking forward to setting up business relationship with you and hope to provide you with the best service and solution. Let us make a better world for our industry!



Contact us

Tel: +86-755-8981 8866 Fax: +86-755-8427 6832

Email & Skype: info@chipsmall.com Web: www.chipsmall.com

Address: A1208, Overseas Decoration Building, #122 Zhenhua RD., Futian, Shenzhen, China



NCV7703GEVB

NCV7703 Evaluation Board User's Manual



ON Semiconductor®

<http://onsemi.com>

EVAL BOARD USER'S MANUAL

Description

The NCV7703 is a fully-protected triple half-bridge driver designed specifically for automotive and industrial motion control applications. The three half-bridge drivers have independent control. This allows for high-side, low side, and H-Bridge control. H-Bridge control provides forward, reverse, brake, and high impedance states.

Driver control is accomplished via a standard Serial Peripheral Interface (SPI).

The Evaluation Board includes both an NCV7703 and NCV8501 5 V regulator. By means of a jumper, the user can select an on-board or external V_{CC} source for the IC. Numerous convenient terminal points are provided to accommodate multiple application configurations.

Features

- Ultra Low Quiescent Current in Sleep Mode
- Three High-Side and Three Low-Side Drivers Connected as Half-Bridges

- Internal Free-wheeling Clamp Diodes
- Configurable as H-Bridge Drivers
- 0.5 A Continuous (1 A peak) Current
- R_{dson} = 0.8 Ω (typ)
- 5 MHz SPI Control with Daisy Chain Capability
- Compliance with 5 V and 3.3 V Systems
- Over Voltage Lockout
- Under Voltage Lockout
- Fault Reporting
- 1.4 A Over Current Threshold Detection with Optional Shutdown
- 3 A Current Limit with Auto Shutdown
- Over Temperature Warning and Protection Levels
- Internally Fused Leads in SON-14 Package



Figure 1. Evaluation Board Photo

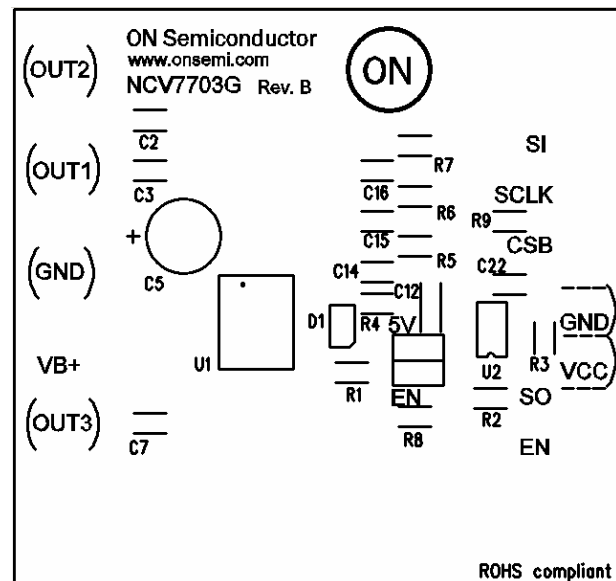

Figure 2. Silkscreen Showing Component Positions of the NCV7703GEVB

NCV7703GEVB

SCHEMATIC

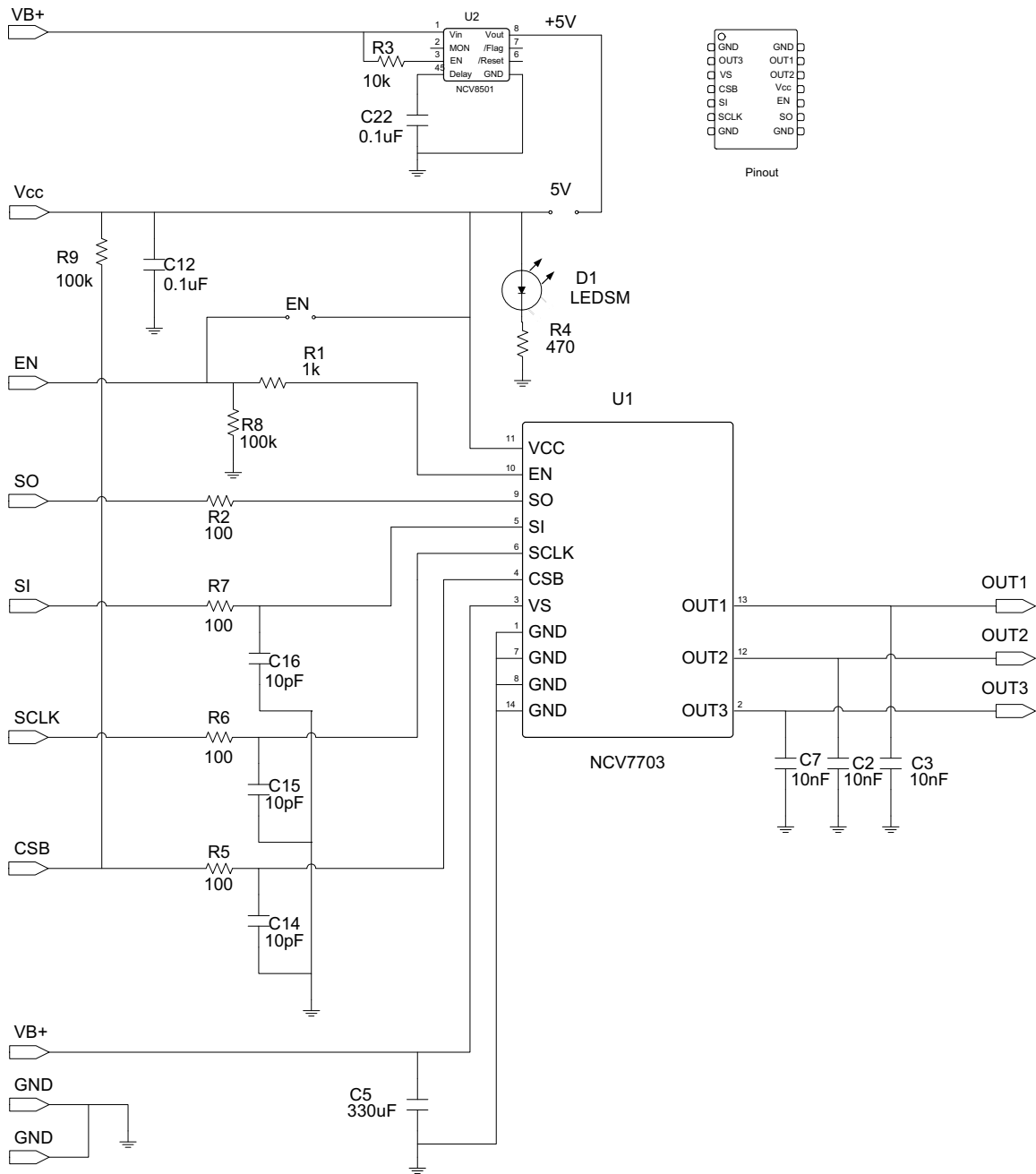

Figure 3. Evaluation Board Schematic

NCV7703GEVB

Typical connections to the evaluation board are shown in Figure 4. The diagram illustrates half-bridge operation of a motor, and the option for a high-side or low-side load. The load connections are for illustration only and do not limit other possible connections.

The connection of the battery or supply (to VB+) powers the board. V_{CC} for the NCV7703 may be powered by the on-board regulator (powered from VB+) with the 5 V jumper. Remove the 5 V jumper if powering from an external source. LED D1 indicates when 5 V is present (powered on-board or externally).

Notice the SO of the SPI controller connects to the SI of the NCV7703GEVB, and the SO of the NCV7703GEVB connects to the SI of the SPI controller.

The Enable jumper hard wires the Enable pin (EN) to be on. The Enable function may also be provided by the SPI Controller. Disconnect the Enable jumper when providing the signal externally.

Refer to the data sheet for SPI interface functionality.

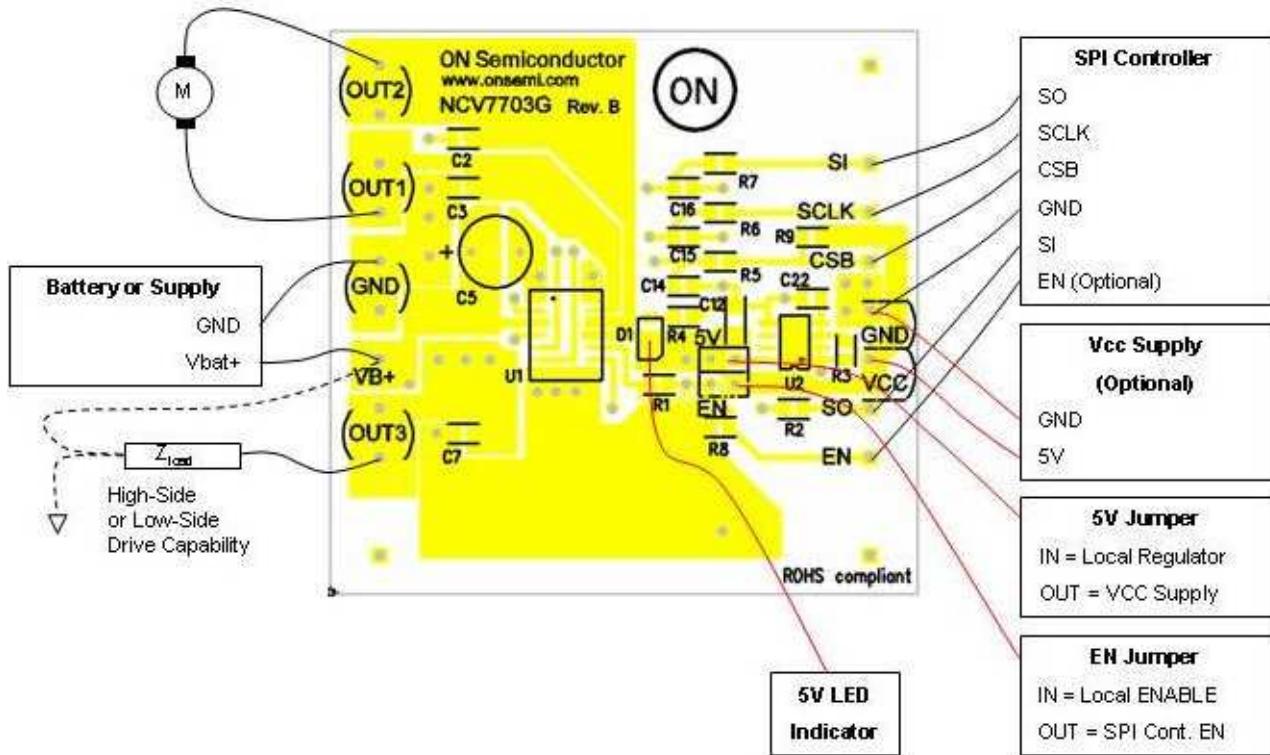

Figure 4. Typical NCV7703 Power Connections

SPI Communication

Standard 16-bit communication has been implemented for the communication of this IC to turn drivers on and off, and to report faults. The LSB (Least Significant Bit) is clocked in first.

Communication is implemented as follows:

1. CSB goes low to allow serial data transfer.
2. A 16 bit word is clocked (SCLK) into the SI (Serial Input) pin.

3. CSB goes high to transfer the clocked in information to the data registers. Note SO is tristate when CSB is high.
4. The SI data will be accepted when a valid SPI frame is detected. A valid SPI frame consists of the above conditions and a complete set of multiples of 16 bit words.

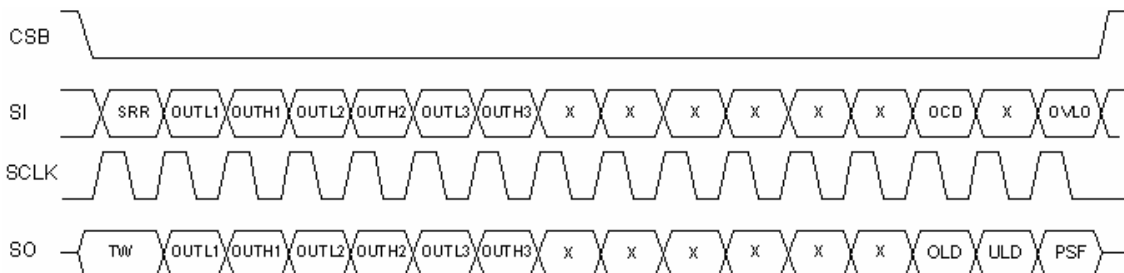

NCV7703GEVB

SPI Communication Frame Format

The table below defines the programming bits and diagnostic bits. Fault information is sequentially clocked out the SO pin of the NCV7703 as programming information is clocked into the SI pin of the device. Daisy

chain communication between SPI compatible IC's is possible by connection of the Serial Output pin (SO) to the input of the sequential IC (SI).

Table 1. PROGRAMMING AND DIAGNOSTIC BITS

Input Data			Output Data		
Bit Number	Bit Description	Bit Status	Bit Number	Bit Description	Bit Status
15	Over Voltage Lock Out Control (OVLO)	0 = Disable	15	Power Supply Fail Signal (PSF for OVLO or UVLO)	0 = No Fault
		1 = Enable			1 = Fault
14	Not Used		14	Under Load Detect Signal (ULD)	0 = No Fault
					1 = Fault
13	Over Current Detection Shut Down Control (OCD)	0 = Disable	13	Over Load Detect Signal (OLD)	0 = No Fault
		1 = Enable			1 = Fault
12	Not Used		12	Not Used	
11	Not Used		11	Not Used	
10	Not Used		10	Not Used	
9	Not Used		9	Not Used	
8	Not Used		8	Not Used	
7	Not Used		7	Not Used	
6	OUTH3	0 = Off	6	OUTH3	0 = Off
		1 = On			1 = On
5	OUTL3	0 = Off	5	OUTL3	0 = Off
		1 = On			1 = On
4	OUTH2	0 = Off	4	OUTH2	0 = Off
		1 = On			1 = On
3	OUTL2	0 = Off	3	OUTL2	0 = Off
		1 = On			1 = On
2	OUTH1	0 = Off	2	OUTH1	0 = Off
		1 = On			1 = On
1	OUTL1	0 = Off	1	OUTL1	0 = Off
		1 = On			1 = On
0	Status Register Reset (SRR)	0 = No Reset	0	Thermal Warning (TW)	0 = Not in TW
		1 = Reset			1 = In TW

Operational Recommendations

Recommended operating voltages for this board are:

$$V_{bat+} = 13.2 \text{ V}$$

$$V_{CC} = 5 \text{ V.}$$

This board is not reverse battery protected. Damage to the board may occur with incorrect connections. The NCV7703 device and C5 (aluminum electrolytic capacitor) are particularly sensitive to reverse battery conditions. See the NCV7703/D datasheet for electrical and environmental testing limits.

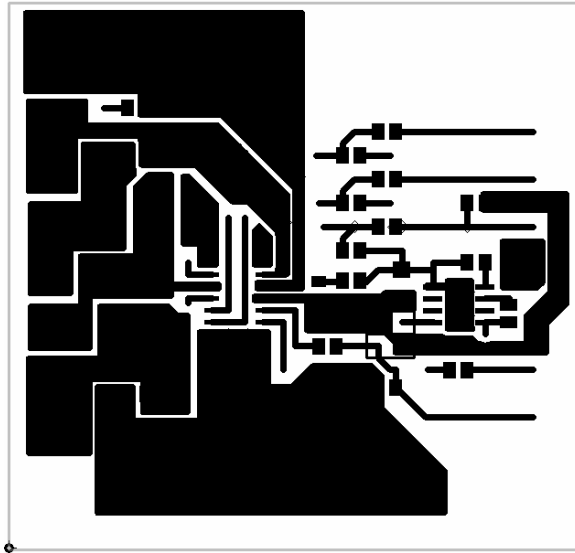

Figure 5. Component Side Etch Pattern

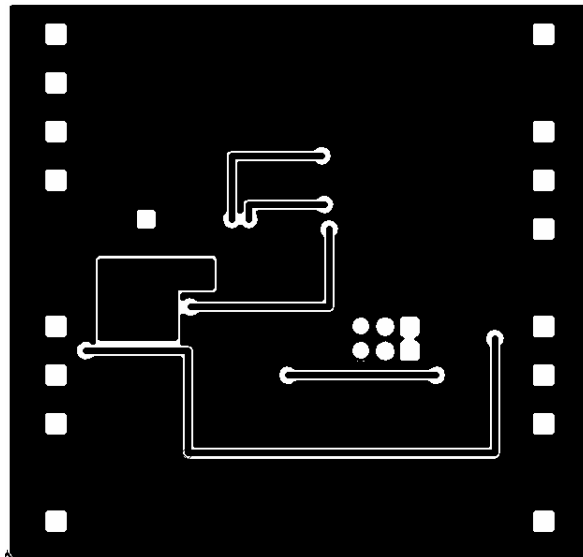

Figure 6. Reverse Side Etch Pattern Shown from Component Side

NCV7703GEVB

BILL OF MATERIALS

Designator	Quantity	Description	Value	Tolerance	Footprint	Manufacturer	Manufacturer Part Number	Substitution Allowed	Lead Free
U1*	1	NCV7703	N/A	N/A	SON-14 (fused)	ON Semiconductor	TBD	No	Yes
U2	1	NCV8501	5V		SO-8	ON Semiconductor	NCV8501D50G	No	Yes
C2, C3, C7	N/A	Output Capacitor*	10pF to 100pF (typ)	N/A	0805	User Supplied	N/A	N/A	N/A
C5	1	VB+ Power Supply Capacitor VCC Power Supply Capacitor	330uF, 50V	20%	Radial 200 mil spacing	United Chemi-Con	ELXZ500ELL331MJ25S	Yes	Yes
C12, C22	1	NCV8501 Bypass Capacitor	0.1uF, 50V	10%	1206	Yageo America	CC1206KRX7R9BB104	Yes	Yes
C14, C15, C16	3	SPI Input Capacitor	10pF, 50V	5%	0805	Yageo America	CC0805JRNPO9BN100	Yes	Yes
R1	1	EN input Resistor	1k	1%	0805	Yageo America	RC0805FR-071KL	Yes	Yes
R2, R5, R6, R7	4	SPI Input Resistor	100	1%	0805	Yageo America	RC0805FR-07100RL	Yes	Yes
R3	1	NCV8501 EN Input Resistor	10k	1%	0805	Yageo America	RC0805FR-0710KL	Yes	Yes
R4	1	LED Current Setting Resistor	470	1%	0805	Yageo America	RC0805FR-07470RL	Yes	Yes
R8, R9	2	EN Pulldown Resistor CSB Pullup Resistor	100k	1%	0805	Yageo America	RC0805FR-07100KL	Yes	Yes
D1	1	VCC Operational green LED	N/A	N/A	2246	Panasonic	LN11361CTR	Yes	Yes
5V, EN	2	Jumper	—	—	—	Sullins Electronic Corp	SSC02SYAN	Yes	Yes
5V, EN	4	Jumper Posts	—	—	100mil spacing	Molex-Waldom Electronics Corp	22-28-4023	Yes	Yes
Various	19	Connector Posts	—	—	42mil diameter	Vector Electronics	K24C/M	Yes	Yes
		* Optional. Capacitor selection is based on application and noise control requirements.							

ON Semiconductor and **ON** are registered trademarks of Semiconductor Components Industries, LLC (SCILLC). SCILLC reserves the right to make changes without further notice to any products herein. SCILLC makes no warranty, representation or guarantee regarding the suitability of its products for any particular purpose, nor does SCILLC assume any liability arising out of the application or use of any product or circuit, and specifically disclaims any and all liability, including without limitation special, consequential or incidental damages. "Typical" parameters which may be provided in SCILLC data sheets and/or specifications can and do vary in different applications and actual performance may vary over time. All operating parameters, including "Typicals" must be validated for each customer application by customer's technical experts. SCILLC does not convey any license under its patent rights nor the rights of others. SCILLC products are not designed, intended, or authorized for use as components in systems intended for surgical implant into the body, or other applications intended to support or sustain life, or for any other application in which the failure of the SCILLC product could create a situation where personal injury or death may occur. Should Buyer purchase or use SCILLC products for any such unintended or unauthorized application, Buyer shall indemnify and hold SCILLC and its officers, employees, subsidiaries, affiliates, and distributors harmless against all claims, costs, damages, and expenses, and reasonable attorney fees arising out of, directly or indirectly, any claim of personal injury or death associated with such unintended or unauthorized use, even if such claim alleges that SCILLC was negligent regarding the design or manufacture of the part. SCILLC is an Equal Opportunity/Affirmative Action Employer. This literature is subject to all applicable copyright laws and is not for resale in any manner.

PUBLICATION ORDERING INFORMATION

LITERATURE FULFILLMENT:

Literature Distribution Center for ON Semiconductor
P.O. Box 5163, Denver, Colorado 80217 USA
Phone: 303-675-2175 or 800-344-3860 Toll Free USA/Canada
Fax: 303-675-2176 or 800-344-3867 Toll Free USA/Canada
Email: orderlit@onsemi.com

N. American Technical Support: 800-282-9855 Toll Free
USA/Canada
Europe, Middle East and Africa Technical Support:
Phone: 421 33 790 2910
Japan Customer Focus Center
Phone: 81-3-5817-1050

ON Semiconductor Website: www.onsemi.com

Order Literature: <http://www.onsemi.com/orderlit>

For additional information, please contact your local Sales Representative