



Chipsmall Limited consists of a professional team with an average of over 10 year of expertise in the distribution of electronic components. Based in Hongkong, we have already established firm and mutual-benefit business relationships with customers from,Europe,America and south Asia,supplying obsolete and hard-to-find components to meet their specific needs.

With the principle of “Quality Parts,Customers Priority,Honest Operation,and Considerate Service”,our business mainly focus on the distribution of electronic components. Line cards we deal with include Microchip,ALPS,ROHM,Xilinx,Pulse,ON,Everlight and Freescale. Main products comprise IC,Modules,Potentiometer,IC Socket,Relay,Connector.Our parts cover such applications as commercial,industrial, and automotives areas.

We are looking forward to setting up business relationship with you and hope to provide you with the best service and solution. Let us make a better world for our industry!



## Contact us

Tel: +86-755-8981 8866 Fax: +86-755-8427 6832

Email & Skype: info@chipsmall.com Web: www.chipsmall.com

Address: A1208, Overseas Decoration Building, #122 Zhenhua RD., Futian, Shenzhen, China





# NCV887801 Start-Stop Demo

## Demonstration Note for NCV887801 Automotive Grade High-Frequency Start-Stop Boost Controller



ON Semiconductor®

<http://onsemi.com>

### Description

This NCV887801 demonstration board provides a convenient way to evaluate a high frequency boost controller designed to supply a minimum output voltage during Start-Stop vehicle battery voltage sags. The unit is in low  $I_q$  sleep-mode under normal battery operating condition and wakes-up when the monitored voltage drops below 7.3 V and begin regulating once 6.8 V is reached. Switching frequency is 450 kHz. The demo board is rated 6.8 V/3.6 A at a 2.6 V input voltage. Operation below 2.6 V is possible if output current is reduced.

### Key Features

- Automatic enable below 7.3V
- Disable Override Function
- Status Indicator
- Boost Operation at 6.8V
- 450kHz Switching Frequency
- Input Undervoltage Lockout
- Wide Input Voltage of 2.6V to 45V
- Low Quiescent Current in Sleep Mode (<12 $\mu$ A Typical)
- Cycle-by-Cycle Current Limit Protection
- Automotive Grade

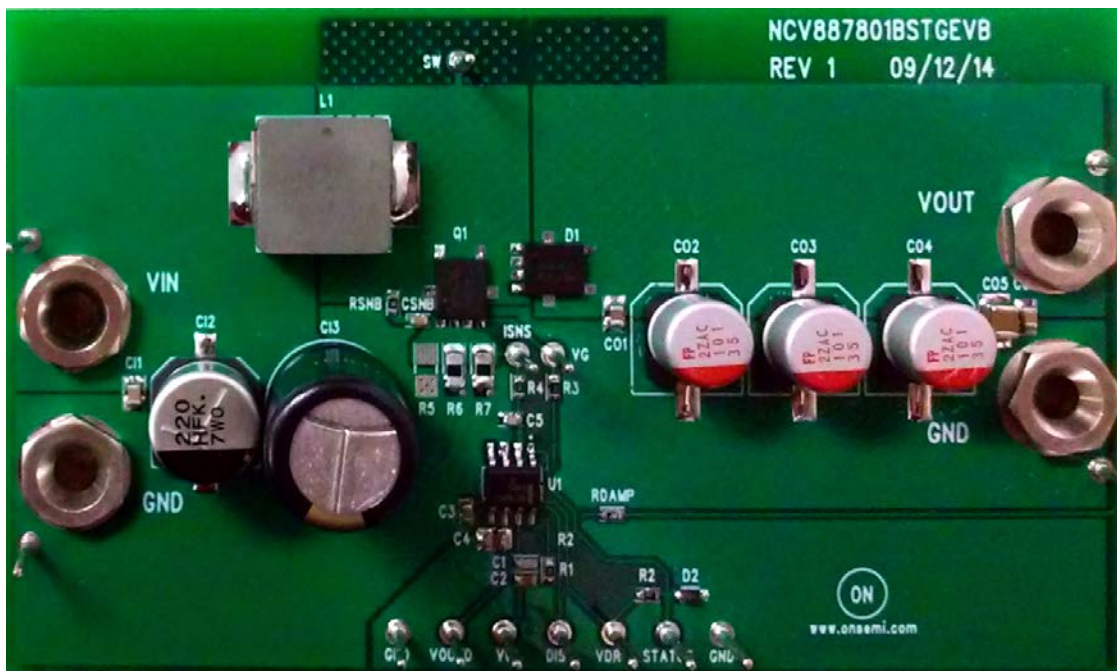

Figure 1. NCV887801 Start-Stop Demo Board

## Demonstration Board Terminals

Terminal	Function
VIN (connector jack)	Positive DC input voltage (power)
GND (connector jack)	Common DC return (power)
VOUT (connector jack)	Regulated DC output voltage (power)
GND (small post)	Common DC return, monitoring point
VC (small post)	Voltage compensation, monitoring point
VOUT (small post)	Regulated DC output voltage, monitoring point
VDRV (small post)	Driving voltage, monitoring point
DISB (small post)	Disable override input, monitoring point
STAT (small post)	Status indicator, monitoring point
ISNS (small post)	Current sense resistor voltage, monitoring point
VG (small post)	MOSFET gate voltage, monitoring point
SW (small post)	MOSFET drain voltage, monitoring point

## Absolute Maximum Ratings

(Voltages are with respect to GND)

Rating	Value	Unit
DC supply voltage (VIN)	-0.3 to 45	V
DC voltage (VC, ISNS)	-0.3 to 3.6	V
DC Voltage (DISB, STAT)	-0.3 to 6	V
Junction Temperature	-40 to 150	°C
Ambient temperature (Demo Board)	-40 to 105	°C

## Electrical Characteristics

( $T_A = 25^\circ\text{C}$ ,  $2.6\text{V} \leq V_{IN} \leq V_{out}$ ,  $V_{DISB} = 5\text{V}$ , unless otherwise specified)

Characteristics	Conditions	Typical Value	Unit
-----------------	------------	---------------	------

### Switching

Switching Frequency	ROSC = 10.7k $\Omega$	450	kHz
---------------------	-----------------------	-----	-----

### Current Limit

Cycle-by-cycle Current Limit (FET)	-	18	A
------------------------------------	---	----	---

### Protections

Maximum Duty Cycle	-	0.83	-
VOUT Undervoltage Lockout (UVLO)	VOUT falling	3.59	V
Thermal Shutdown	$T_A$ increasing	170	°C

## Operational Guidelines

The demo board is rated to operate under full load for input voltage as low as 2.6V at the input terminal under full power (less if output current is reduced). Start-Stop applications use reverse battery protection diodes in front of the boost converter (Fig. 2), so the input source can operate down to 2.6V plus a diode drop (i.e. ~3V).

### Notes:

- a. The IC UVLO (undervoltage lockout) is 4.05V for VOUT rising, 3.59V for VOUT falling (0.54V hysteresis).
- b. Limit time spent with the power supply operating at minimum input voltage (equivalent to  $V_{IN} = 2.6V$ ) to avoid overheating the power semiconductors.

### First Time Power-Up:

1. Connect a DC source voltage (15A capable) set to a voltage of 12-13V as shown in Fig. 1.
2. Connect the DISB TTL control signal as shown in Fig. 1. The initial DISB state should be set to logic-'0'.
3. Connect a 3.6A constant current load on the output.
4. Decrease the DC input voltage until the PCB VIN voltage is  $5.5V \pm 0.5V$ .
5. Set the DISB control signal to a TTL high state (i.e. 5V).
6. Verify that the unit is regulating at  $V_{OUT} = 6.8V$ .
7. Reduce the DC input voltage until the PCB VIN = 2.6V. Verify that the unit is regulating at  $V_{OUT} = 6.8V$ .

### Start-Stop Voltage Transient Test:

1. Connect both DC1 and DC2 input power supplies as illustrated in Fig. 2. Adjust DC2 so that PCB VIN = 2.6V for a 3.6A load.
2. Connect a 3.6A load on the output. If a load resistor is used, it is recommended to start from a DC1 input voltage of 8.5-9.0V to avoid overstressing the PCB boost diode (D1, rated 4A).
3. Monitor VOUT. Disconnect supply DC1. VOUT should have a response similar to that of Fig 3.

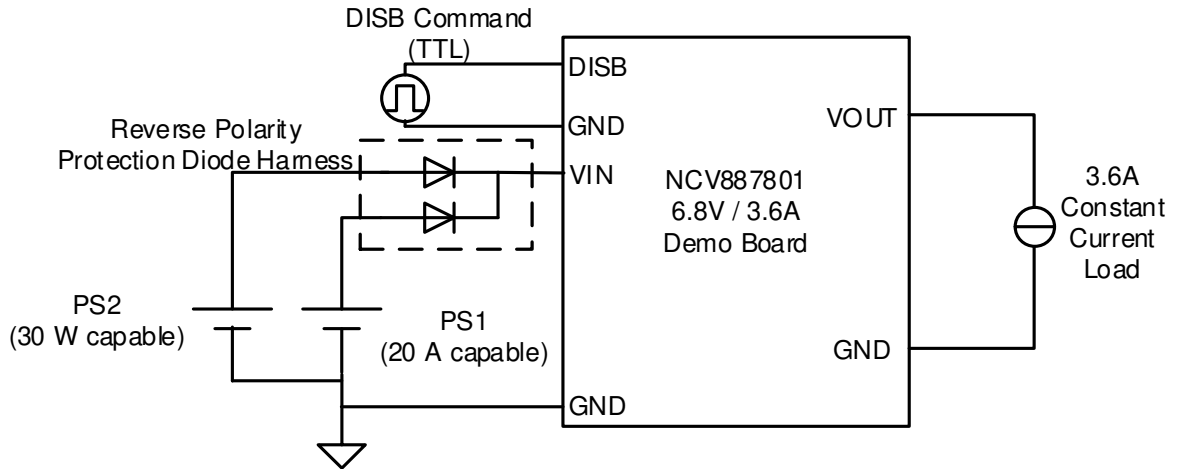

Figure 2. Demo Board Connections

## Typical Performance

### DC1 is disabled, then re-enabled

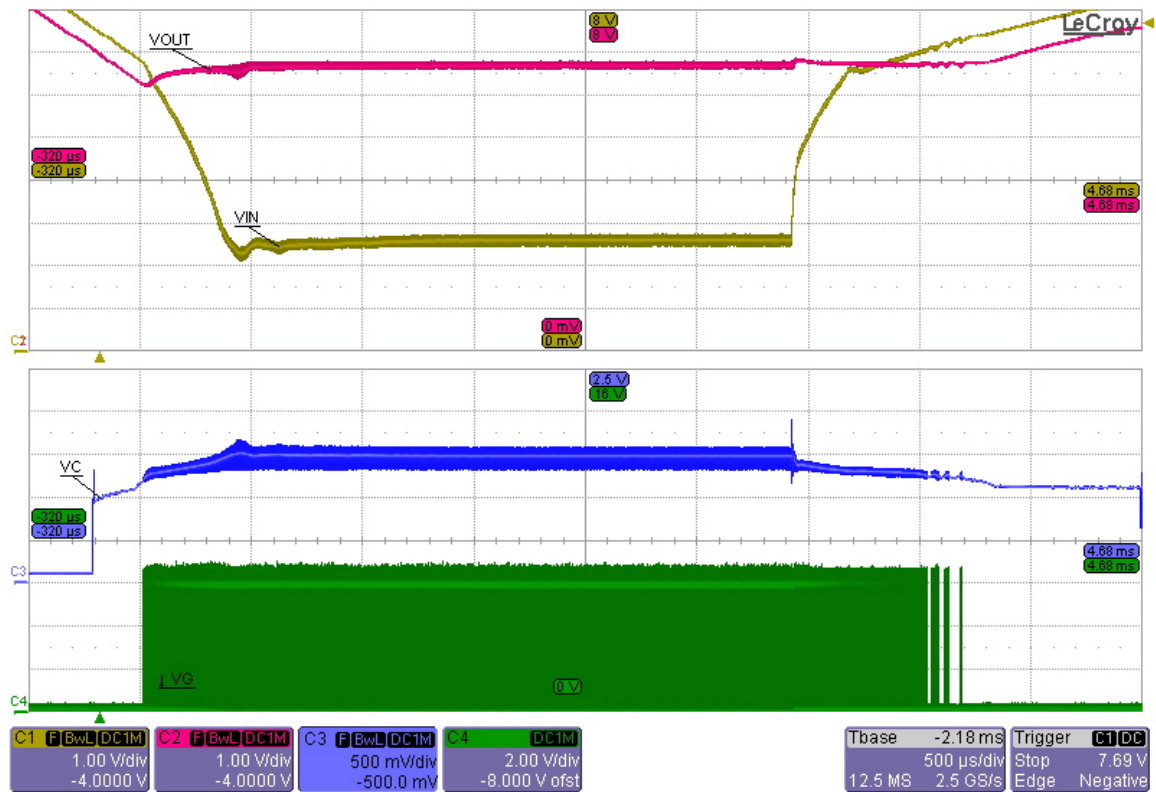

Figure 3 NCV887801 Demo Board Waveforms

- DC2 at VIN adjusted to 2.6V (after reverse polarity protection diode)
- VOUT = 6.8V, I<sub>OUT</sub> = 3.6A

# Schematic

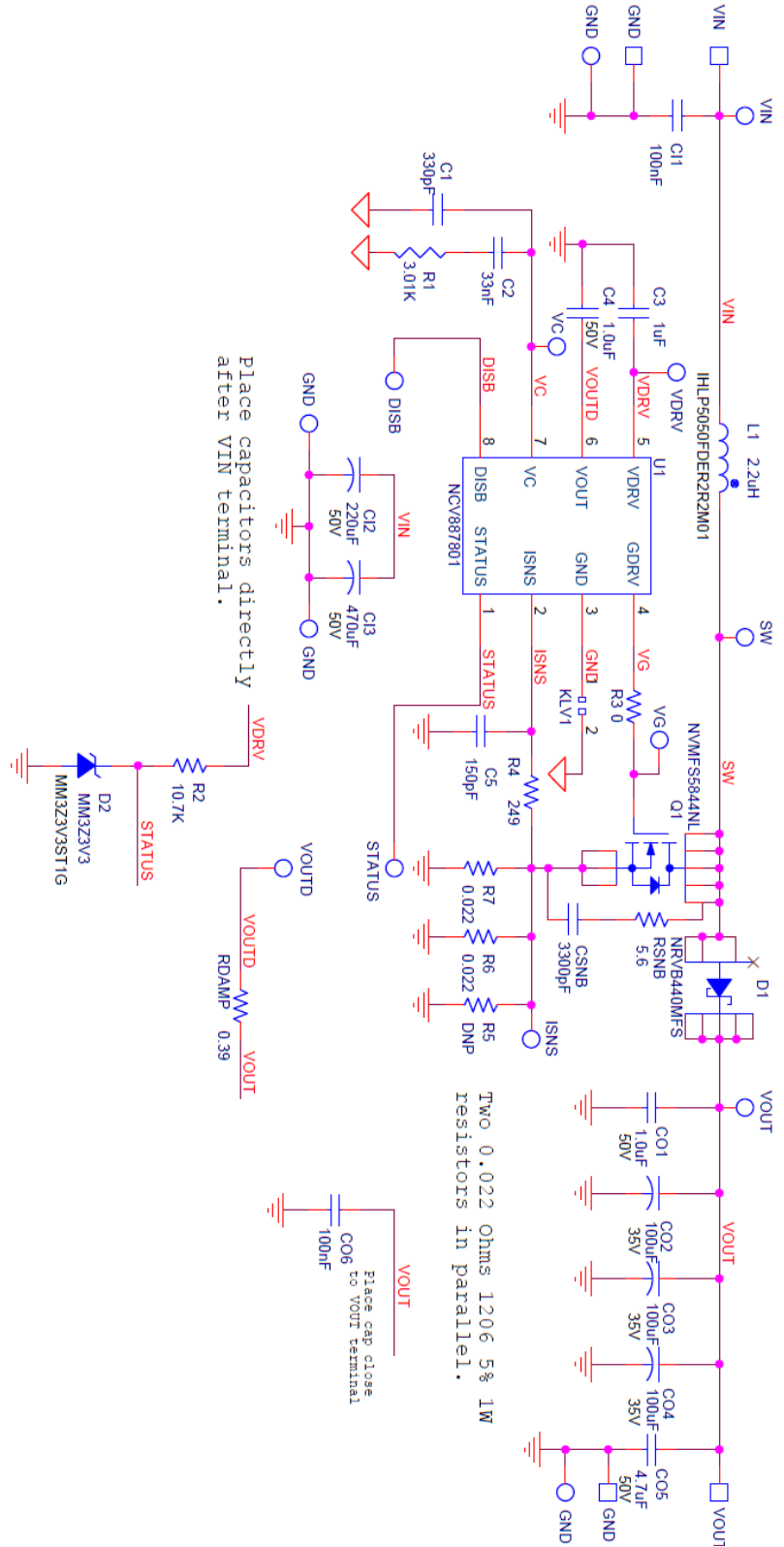

Figure 4. NCV887801 boost 6.8V/3.6A demonstration board schematic

## Bill of Materials

Reference Designator(s)	Quantity	Description	Value	Tolerance	Manufacturer	Manufacturer's Part Number	Substitution Allowed	RoHS Compliant
C1	1	CAP CER 330PF 50V 5% NPO 0603	330pF	5%	Murata Electronics North America	GCM1885C1H331JA16D	Yes	Yes
C2	1	CAP CER 0.033UF 50V 10% X7R 0603	0.033uF	10%	TDK Corporation	CGA3E2X7R1H333K080AA	Yes	Yes
C3	1	CAP CER 1UF 16V 10% X7R 0603	1uF	10%	Murata Electronics North America	GCM188R71C105KA64D	Yes	Yes
C4, CO1	2	CAP CER 1UF 50V 10% X7R 0805	1.0uF	10%	TDK Corporation	CGA4J3X7R1H105K125AB	Yes	Yes
C5	1	CAP CER 150PF 50V 5% NPO 0603	150pF	5%	Murata Electronics North America	GCM1885C1H151JA16D	Yes	Yes
CI1, CO6	2	CAP CER 0.1UF 50V 10% X7R 0805	100nF	10%	Murata Electronics North America	GCM21BR71H104KA37L	Yes	Yes
CI2	1	CAP ALUM 220UF 50V 20% SMD	220uF	20%	Chemi-Con	EMZA500ADA221MJA0G	Yes	Yes
CI3	1	CAP ALUM 470UF 50V 20% RADIAL	470uF	20%	Panasonic Electronic Components	EEU-FC1H471	Yes	Yes
CO2, CO3, CO4	3	CAP ALUM 100UF 35V 20% SMD	100uF	20%	Nichicon	RHS1V101MCM1GS	No	Yes
CO5	1	CAP CER 4.7UF 50V 10% X7R 1210	4.7uF	10%	Murata Electronics North America	GCM32ER71H475KA55L	Yes	Yes
CSNB	1	CAP CER 3300PF 50V 5% NPO 0603	3300pF	5%	TDK Corporation	CGA3E2C0G1H332J080AA	Yes	Yes
D1	1	40 V, 4.0 A Schottky Rectifier SO8-FL	40V / 4A	N/A	ON Semiconductor	NRVB440MFST1G	No	Yes
D2	1	DIODE ZENER 3.3V 200MW SOD323	3.3V	5%	ON Semiconductor	MM3Z3V3T1G	Yes	Yes
L1	1	INDUCTOR POWER 2.2UH 22A SMD	2.2uH	20%	Vishay Dale	IHLP5050FDER2R2M01	No	Yes
Q1	1	N-Channel Power MOSFET 60V 61A SO-	60V / 61A	N/A	ON Semiconductor	NVMFS5844NL	No	Yes
R1	1	RES 3.01K OHM 1/10W 1% 0603 SMD	3.01K	1%	Vishay Dale	CRCW06033K01FKEA	Yes	Yes
R2	1	RES 10.7K OHM 1/10W 1% 0603 SMD	10.7k	1%	Vishay Dale	CRCW060310K7FKEA	Yes	Yes
R3	1	RES 0.0 OHM 1/10W JUMP 0603 SMD	0	Jumper	Vishay Dale	CRCW06030000Z0EA	Yes	Yes
R4	1	RES 249 OHM 1/10W 1% 0603 SMD	249	1%	Vishay Dale	CRCW0603249RFKEA	Yes	Yes
R5	DNP							
R6, R7	2	RES 0.022 OHM 1W 5% 1206 SMD	0.022	5%	Panasonic Electronic Components	ERJ-8BWJR022V	No	Yes
RDAMP	1	RES 0.39 OHM 1/10W 1% 0603 SMD	0.39	1%	Panasonic Electronic Components	ERJ-3RQFR39V	Yes	Yes
RSNB	1	RES 5.60 OHM 1/10W 1% 0603 SMD	5.6	1%	Vishay Dale	CRCW06035R60FKEA	Yes	Yes
GND1, GND2, VIN1, VOUT	4	TERM SOLDER TURRET .219" .109"L	N/A	N/A	Mill-Max Manufacturing Corp.	2501-2-00-44-00-00-07-0	Yes	Yes
DISB, GND2, GND4, GND5, GND6, ISNS, SW, VC, VDRV, VG, VIN2, VOUT1, VOUT2	13	PIN INBOARD .042" HOLE 1000/PKG	N/A	N/A	Vector Electronics	K24C/M	Yes	Yes
U1	1	Automotive Non-Sync Boost Controller	N/A	N/A	ON Semiconductor	NCV887801	No	Yes



# PCB Layout

NCV887801 Demo Board Rev 1  
TOP Layer 09/12/2014

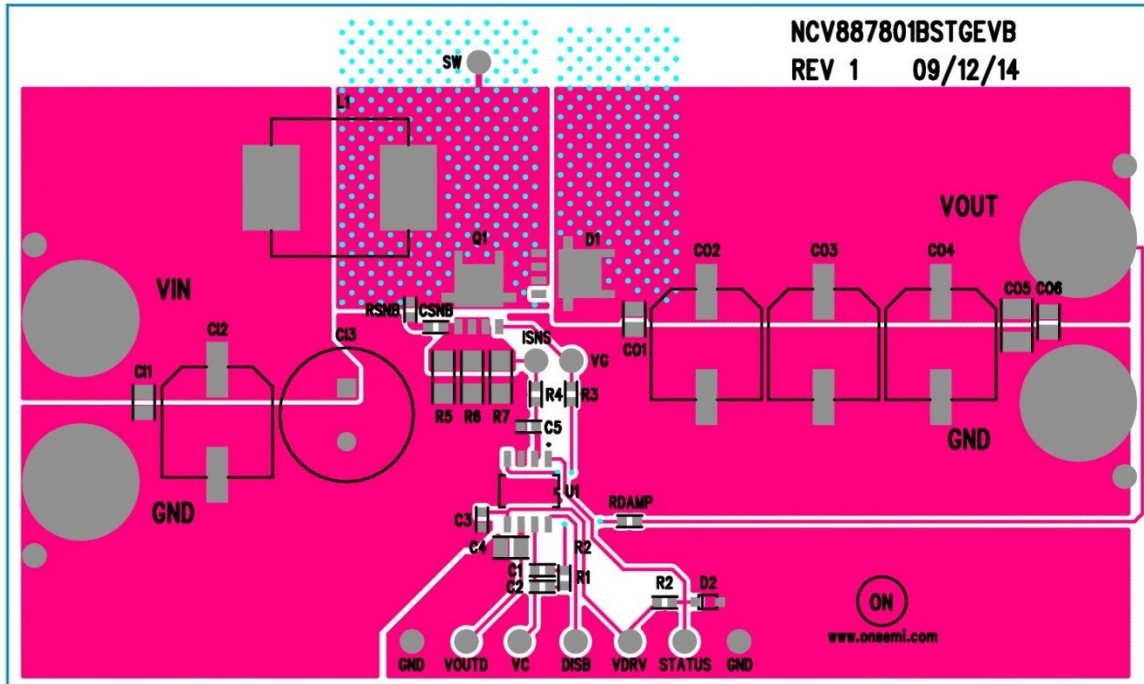

Figure 5. Top View

NCV887801 Demo Board Rev 1  
BOTTOM Layer 09/12/2014

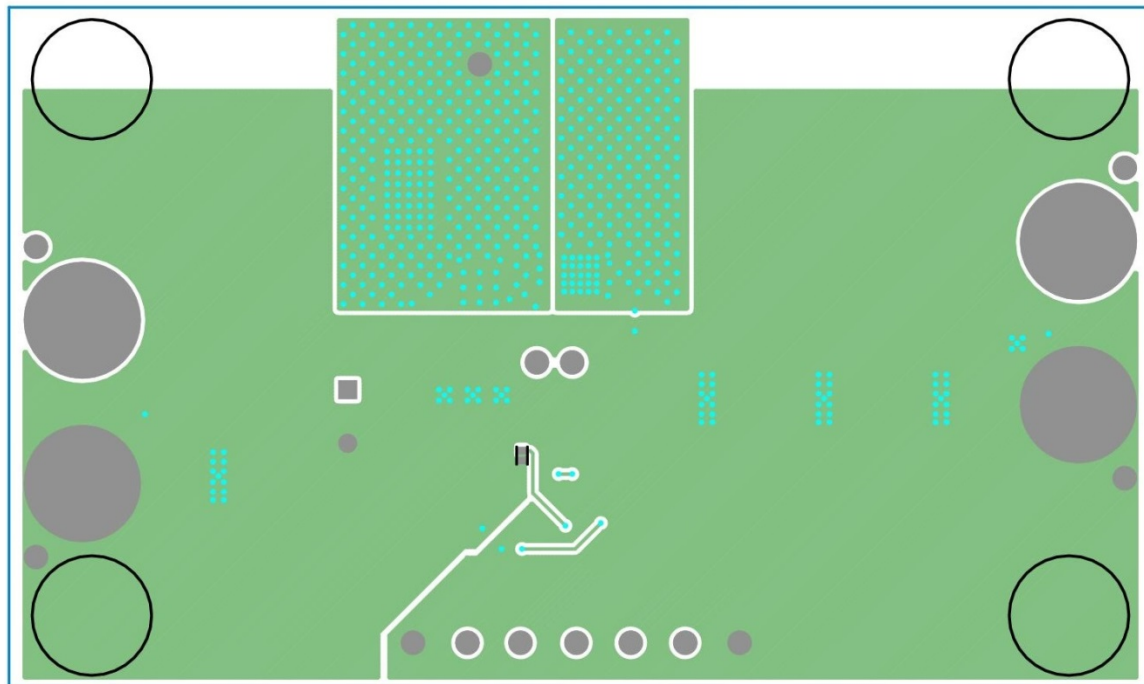

Figure 6. Bottom View



### Typical performance

#### NCV887801 Efficiency (25C)

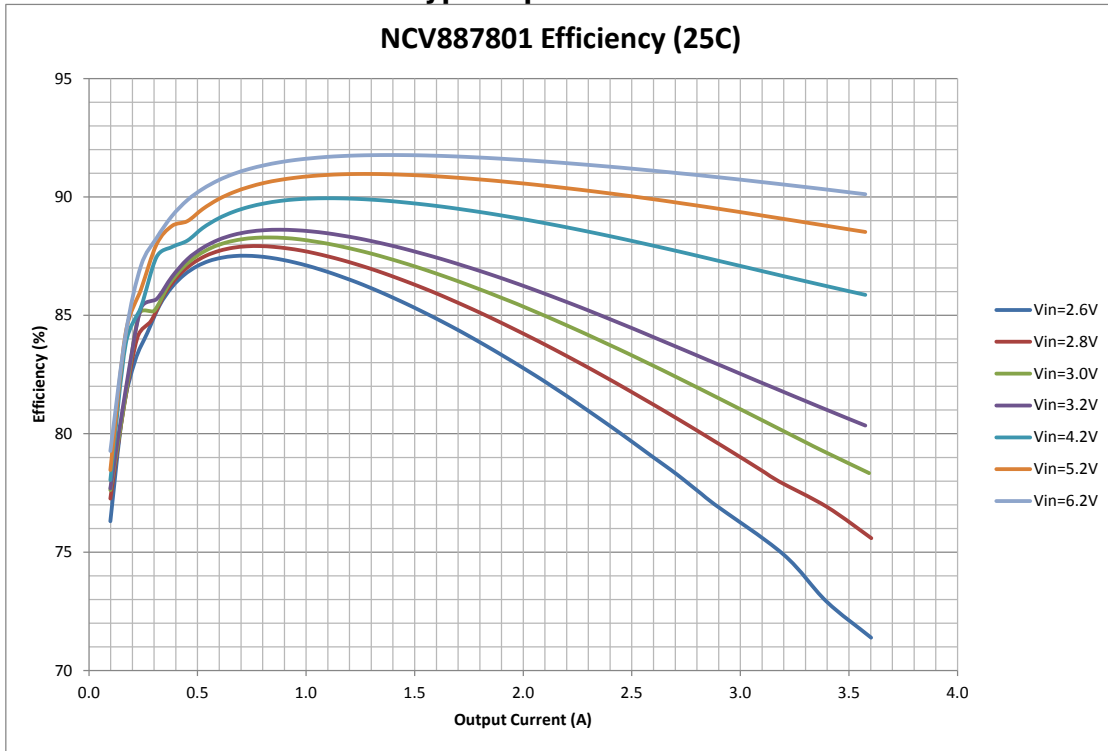

Figure 7 NCV887801 Efficiency

#### NCV887801 6.8 V Line Regulation

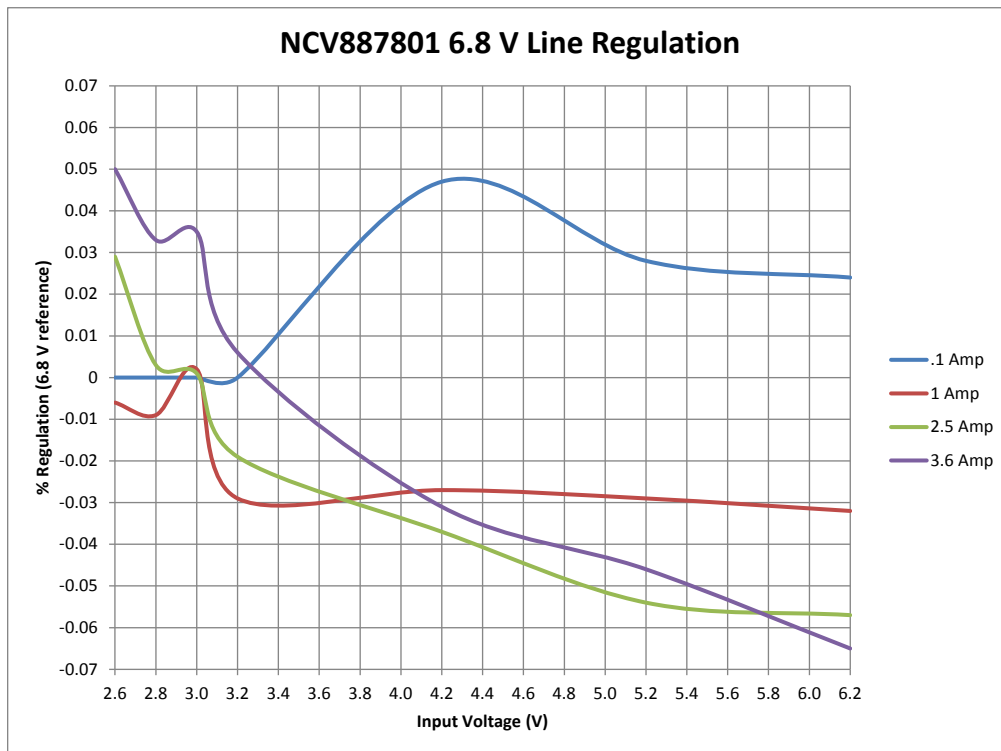
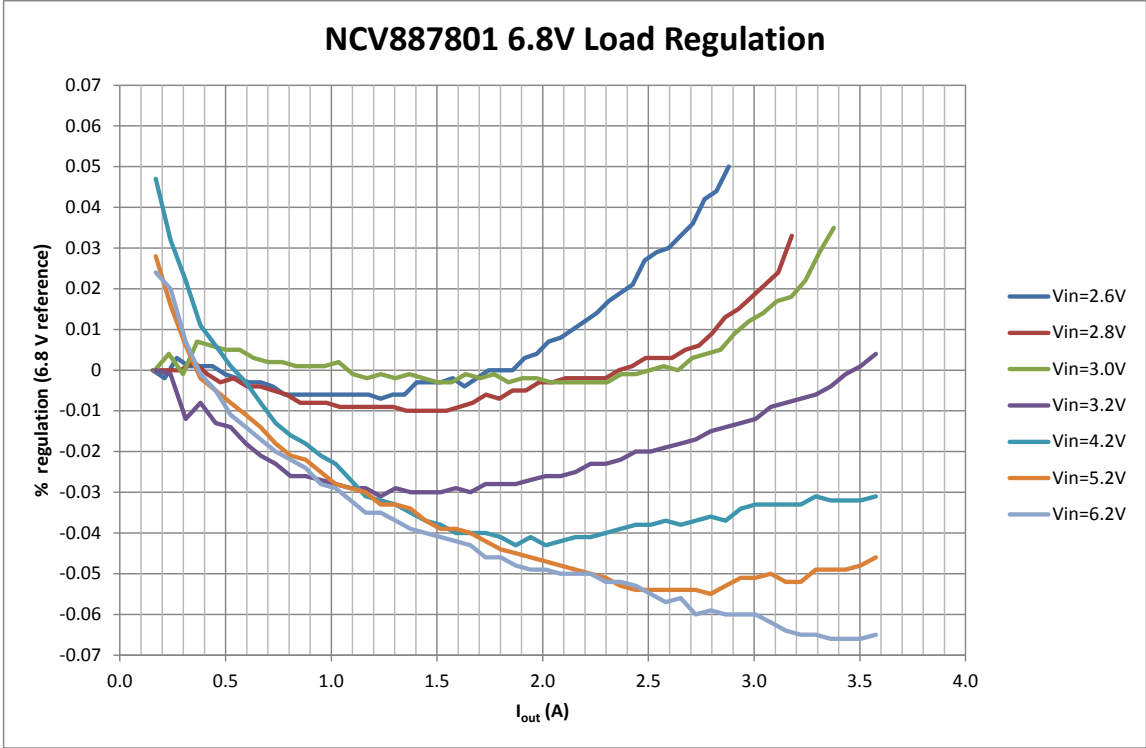

Figure 8 NCV887801 Line Regulation



**Figure 9 NCV887801 Load Regulation**