



Chipsmall Limited consists of a professional team with an average of over 10 year of expertise in the distribution of electronic components. Based in Hongkong, we have already established firm and mutual-benefit business relationships with customers from,Europe,America and south Asia,supplying obsolete and hard-to-find components to meet their specific needs.

With the principle of “Quality Parts,Customers Priority,Honest Operation,and Considerate Service”,our business mainly focus on the distribution of electronic components. Line cards we deal with include Microchip,ALPS,ROHM,Xilinx,Pulse,ON,Everlight and Freescale. Main products comprise IC,Modules,Potentiometer,IC Socket,Relay,Connector.Our parts cover such applications as commercial,industrial, and automotives areas.

We are looking forward to setting up business relationship with you and hope to provide you with the best service and solution. Let us make a better world for our industry!



Contact us

Tel: +86-755-8981 8866 Fax: +86-755-8427 6832

Email & Skype: info@chipsmall.com Web: www.chipsmall.com

Address: A1208, Overseas Decoration Building, #122 Zhenhua RD., Futian, Shenzhen, China



Test Procedure for the NCV97311MW33GEVB Evaluation Board

Introduction: The NCV97311 is a 3-output regulator consisting of a low-Iq battery-connected 3A 2 MHz non-synchronous switcher and two low-voltage 1.5A 2 MHz synchronous switchers; all using integrated power transistors. The high-voltage switcher is capable of converting a 4.1V to 18V battery input to a 5V or 3.3V output at a constant 2MHz switching frequency, delivering up to 3A. In overvoltage conditions up to 36V, the switching frequency folds back to 1 MHz; in load dump conditions up to 45V the regulator shuts down.

Test Procedure:

1. Connect a dc input voltage, within the 6.0 V to 36 V range, between VBAT and GND.
2. Connect a load (< 150 mA) between VOUT1 and GND
3. Connect a dc enable voltage, within the 2.0 V to 36 V range, between EN and GND. This will enable the internal LDO for low Iq mode. You may use jumper J1 to connect EN directly to VBAT.
 - a. The VOUT1 signal should be 3.3 V.
 - b. The VOUT2 signal should be disabled (regardless of EN2 state) and read 0 V.
 - c. The VOUT3 signal should be disabled (regardless of EN3 state) and read 0 V.
4. Connect a dc enable voltage, within the 2.0 V to 36 V range, between STBYB and GND. This will exit low Iq mode and power up switcher 1. You may use jumper J2 to connect STBYB directly to VBAT. The VOUT1 signal should still be 3.3 V. You may now add a higher load to VOUT1.
5. Connect a dc enable voltage, within the 2.0 V to 6 V range, between EN2 and GND. This will power up switcher 2. You may use jumper J4 to connect EN2 directly to VOUT1. The VOUT2 signal should be 1.8 V.
6. Connect a dc enable voltage, within the 2.0 V to 6 V range, between EN3 and GND. This will power up switcher 3. You may use jumper J3 to connect EN3 directly to VOUT1. The VOUT3 signal should be 1.2 V.

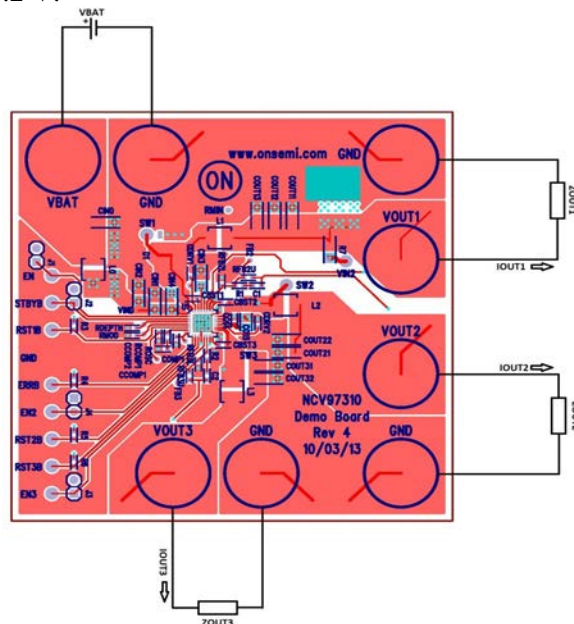

Figure 5. NCV97311 Board Connections