



Chipsmall Limited consists of a professional team with an average of over 10 year of expertise in the distribution of electronic components. Based in Hongkong, we have already established firm and mutual-benefit business relationships with customers from,Europe,America and south Asia,supplying obsolete and hard-to-find components to meet their specific needs.

With the principle of “Quality Parts,Customers Priority,Honest Operation,and Considerate Service”,our business mainly focus on the distribution of electronic components. Line cards we deal with include Microchip,ALPS,ROHM,Xilinx,Pulse,ON,Everlight and Freescale. Main products comprise IC,Modules,Potentiometer,IC Socket,Relay,Connector.Our parts cover such applications as commercial,industrial, and automotives areas.

We are looking forward to setting up business relationship with you and hope to provide you with the best service and solution. Let us make a better world for our industry!



Contact us

Tel: +86-755-8981 8866 Fax: +86-755-8427 6832

Email & Skype: info@chipsmall.com Web: www.chipsmall.com

Address: A1208, Overseas Decoration Building, #122 Zhenhua RD., Futian, Shenzhen, China





FEATURES

- RoHS compliant
- 2:1 Wide range voltage input
- Continuous short circuit protection with current foldback
- Operating temperature range -40°C to 85°C
- 0.2% Typical load regulation
- 1kVDC Isolation
- Efficiency from 67%
- 5V, 12V, 24V & 48V Nominal input
- 5V, 12V & 15V outputs
- Power density $0.94\text{W}/\text{cm}^3$
- Optional remote On/Off
- UL 94V-0 Package materials
- No electrolytic capacitors
- Low noise
- Custom solutions available

PRODUCT OVERVIEW

The NDX series of DC/DC converters provide up to 7.5W of output power with single or dual outputs. Unbalanced loading capability with an optional input control pin. Input voltages of 5V (4.5V to 9V), 12V (9V to 18V), 24V (18V to 36V), and 48V (36V to 75V) with outputs of 5V, 12V or 15V provided. The device is housed in a 5 sided metal case potted with UL 94V-0 rated material. The pinout is an industry standard 5 pin arrangement with an additional optional control pin.

SELECTION GUIDE

Order Code ¹	Nominal Input Voltage	Output Voltage	Output Current at 25% Load ²	Output Current at 100% Load ²	Input Current at 0% Load	Input Current at 100% Load	Input Current at shutdown	Ripple & Noise ³ (Typ.)	Ripple & Noise ³ (Max.)	Efficiency (Min.)	Isolation Capacitance	Closest Alternative (click for data sheet)
	V	V	mA	mA	mA	A	mA	mVp-p	mVp-p	%	pF	NCS6 Series
NDXS0512C	5	12	156	625	42	2.02		79	110	68	55	
NDXS0512EC	5	12	156	625	42	2.02	0.48	79	110	68	55	
NDXS0515C	5	15	125	500	46.2	2.02		55	80	67	49	
NDXS0515EC	5	15	125	500	46.2	2.02	0.46	55	80	67	49	
NDXS1212C	12	12	156	625	19.4	0.77		31	50	77	56	NCS6S1212C
NDXS1212EC	12	12	156	625	19.4	0.77	0.51	31	50	77	56	NCS6S1212C
NDXS1215C	12	15	125	500	27	0.77		23	40	77	53	NCS6S1215C
NDXS1215EC	12	15	125	500	27	0.77	0.51	23	40	77	53	NCS6S1215C
NDXS2412C	24	12	156	625	13.8	0.38		24	50	80	55	NCS6S1212C
NDXS2412EC	24	12	156	625	13.8	0.38	0.53	24	50	80	55	NCS6S1212C
NDXS2415C	24	15	125	500	20.6	0.37		24	45	80	56	NCS6S1215C
NDXS2415EC	24	15	125	500	20.6	0.37	0.53	24	45	80	56	NCS6S1215C
NDXS4812C	48	12	156	625	8.8	0.187		20	40	81	58	NCS6S4812C
NDXS4812EC	48	12	156	625	8.8	0.187	0.47	20	40	81	58	NCS6S4812C
NDXS4815C	48	15	125	500	10.2	0.187		20	40	82	58	NCS6S4815C
NDXS4815EC	48	15	125	500	10.2	0.187	0.48	20	40	82	58	NCS6S4815C
NDXD0505C	5	± 5	± 150	± 600	19.4	1.83		20	40	67	40	
NDXD0505EC	5	± 5	± 150	± 600	19.4	1.83	0.075	20	40	67	40	
NDXD0512C	5	± 12	± 78.1	± 312	33.4	2.15		21	45	69	42	
NDXD0512EC	5	± 12	± 78.1	± 312	33.4	2.15	0.075	21	45	69	42	
NDXD0515C	5	± 15	± 62.5	± 250	41.8	2.69		15	35	71	43	
NDXD0515EC	5	± 15	± 62.5	± 250	41.8	2.69	0.075	15	35	71	43	
NDXD1205C	12	± 5	± 187	± 750	13.2	0.89		20	45	73	36	NCS6D1205C
NDXD1205EC	12	± 5	± 187	± 750	13.2	0.89	0.176	20	45	73	36	NCS6D1205C
NDXD1212C	12	± 12	± 78.1	± 312	15	0.86		25	55	78	41	NCS6D1212C
NDXD1212EC	12	± 12	± 78.1	± 312	15	0.86	0.159	25	55	78	41	NCS6D1212C
NDXD1215C	12	± 15	± 62.5	± 250	17	0.86		30	60	79	41	NCS6D1215C
NDXD1215EC	12	± 15	± 62.5	± 250	17	0.86	0.175	30	60	79	41	NCS6D1215C
NDXD2405C	24	± 5	± 187	± 750	4.2	0.402		35	60	75	58	NCS6D1205C
NDXD2405EC	24	± 5	± 187	± 750	4.2	0.402	0.15	35	60	75	58	NCS6D1205C
NDXD2412C	24	± 12	± 78.1	± 312	6.3	0.38		25	55	81	56	NCS6D1212C
NDXD2412EC	24	± 12	± 78.1	± 312	6.3	0.38	0.4	25	55	81	56	NCS6D1212C
NDXD2415C	24	± 15	± 62.5	± 250	7	0.38		30	60	82	56	NCS6D1215C
NDXD2415EC	24	± 15	± 62.5	± 250	7	0.38	0.4	30	60	82	56	NCS6D1215C
NDXD4805C	48	± 5	± 187	± 750	3.6	0.198		20	40	77	61	NCS6D4805C
NDXD4805EC	48	± 5	± 187	± 750	3.6	0.198	0.08	20	40	77	61	NCS6D4805C
NDXD4812C	48	± 12	± 78.1	± 312	5.9	0.19		25	45	82	57	NCS6D4812C
NDXD4812EC	48	± 12	± 78.1	± 312	5.9	0.19	0.5	25	45	82	57	NCS6D4812C
NDXD4815C	48	± 15	± 62.5	± 250	5.9	0.19		22	55	82	58	NCS6D4815C
NDXD4815EC	48	± 15	± 62.5	± 250	5.9	0.19	0.5	22	55	82	58	NCS6D4815C

1. Suffix 'EC' indicates optional CTRL pin is fitted, as indicated in the mechanical dimensions section.

2. Please refer to minimum load application notes section on page 4.

3. See ripple & noise characterisation method.

All specifications typical at $T_A=25^{\circ}\text{C}$, with recommended input/output capacitors (refer to application note), nominal input voltage and rated output current unless otherwise specified.



INPUT CHARACTERISTICS					
Parameter	Conditions	Min.	Typ.	Max.	Units
Voltage range	5V input types	4.5	5	9	V
	12V input types	9	12	18	
	24V input types	18	24	36	
	48V input types	36	48	75	
Reflected ripple current	Dual outputs	5V input types with 100µF at input		70	mA p-p
		12V input types with 100µF at input		18	
		24V input types with 10µF at input		90	
		48V input types with 10µF at input		80	
	Single outputs	5V input types with 100µF at input		115	
		12V input types with 100µF at input		60	
		24V input types with 10µF at input		50	
		48V input types with 10µF at input		54	
Ripple & noise ¹	BW=20Hz to 300kHz, with external input/output capacitors		5	10	mVrms

OUTPUT CHARACTERISTICS						
Parameter	Conditions	Min.	Typ.	Max.	Units	
Rated power	NDX0505 types			6.0	W	
	All other types			7.5		
Voltage set point accuracy	With external input/output capacitors	5V & 12V Input	±3	±5	%	
		24V & 48V Input	±2	±5		
Line regulation	Low line to high line, with external input/output capacitors	Dual output	5V & 12V Input	0.1	0.9	%
			24V & 48V Input	0.04	0.4	
		Single output	All types	0.04	0.4	
Load regulation	25% total load to 100% total load With external input/output capacitors	Dual output	5V & 12V input	0.2	0.9	%
			24V & 48V input	0.2	0.75	
		Single output	All types	0.07	0.20	
Cross regulation (dual outputs)	% voltage change on negative output when positive load varies from 25% to 75% with negative load fixed at 100%	5V & 12V input	5V output	3.8	6	%
			12V, 15V output	1.5	5	
		24V & 48V input	5V output	2.5	7	
			12V, 15V output	2.5	5	

ABSOLUTE MAXIMUM RATINGS		
Short-circuit protection (Max. case temperature rise 95°C above ambient)	12V, 15V outputs	Continuous
	5V output, VIN = nominal, 25°C	Continuous
Lead temperature 1.0mm from case for 10 seconds (to JEDEC JESD22-B106 ISS C)		260°C
Minimum output load for specification ²		25% of rated load on each output
Control pin input voltage		7V
Input voltage, NDXD05,		10V
Input voltage, NDXD12, NDXS12 types		20V
Input voltage, NDXD24, NDXS24 types		40V
Input voltage, NDXD48, NDXS48 types		80V

ISOLATION CHARACTERISTICS					
Parameter	Conditions	Min.	Typ.	Max.	Units
Isolation test voltage	Flash tested for 1 second	1000			VDC
Resistance	Viso = 1kVDC	1			GΩ

1. See ripple & noise characterisation method
2. Please refer to minimum load application notes section on page 4.

GENERAL CHARACTERISTICS							
Parameter	Conditions			Min.	Typ.	Max.	Units
Switching frequency	100% total load to 25% total load (Dual Output Types)	5V & 12V input	5V, 12V & 15V outputs	100		900	kHz
		24V & 48V input	5V outputs	100		680	
	12V & 15V outputs				620		
	100% total load to 25% total load (Single Output Types)	5V, 12V & 24V input	12V & 15V output	90		850	
48V input		12V & 15V output	90		600		
Control pin input ¹	Module ON (or pin unconnected)	Single outputs		-0.6		0.8	V
				0		0.1	mA
		Dual outputs		-0.6		0.8	V
	-0.1				0.2	mA	
	Module OFF	Single outputs		3.0		7.0	V
				0.7		3.0	mA
Dual outputs		3.0		7.0	V		
		0.3		3.0	mA		

TEMPERATURE CHARACTERISTICS							
Parameter	Conditions			Min.	Typ.	Max.	Units
Operation				-40		85	°C
Storage				-50		130	
Case temperature rise above ambient	100% Load, Nom V _{IN} , Still Air	1212, 1215, 2412, 2415, 4812, 4815			35		
		0512, 2405, 4805			43		
		0505, 0515, 1205			48		

MEAN TIME TO FAILURE (MTTF) ²				
Part Number	0°C	25°C	Units	
NDXD2412C	2590	1528	kHrs	
NDXD2415C	2492	1462		
NDXD4812C	2587	1558		
NDXD4815C	2351	1379		

1. See application notes on page 4.

2. Calculated using MIL-HDBK-217F with nominal input voltage at full load.

All specifications typical at T_A=25°C, nominal input voltage and rated output current unless otherwise specified.

RoHS COMPLIANCE INFORMATION	
	This series is compatible with RoHS soldering systems with a peak wave solder temperature of 260°C for 10 seconds. The pin termination finish on this product series is a Gold flash (0.05-0.10 micron) over Nickel Preplate. The series is backward compatible with Sn/Pb soldering systems. For further information, please visit www.murata-ps.com/rohs

APPLICATION NOTES

External Capacitance

Although these converters will work without external capacitors, they are necessary in order to guarantee the full parametric performance over the full line and load range. All parts have been tested and characterised using the following values and test circuit.

Input Voltage	C _{IN}	Value	
		C _{OUT1}	C _{OUT2}
5V & 12V	100µF, 100V	0.1µF, 25V multi-layer ceramic	100µF, 25V (low ESR)
24V & 48V	10µF, 200V		

Recommended Input & Output Capacitors

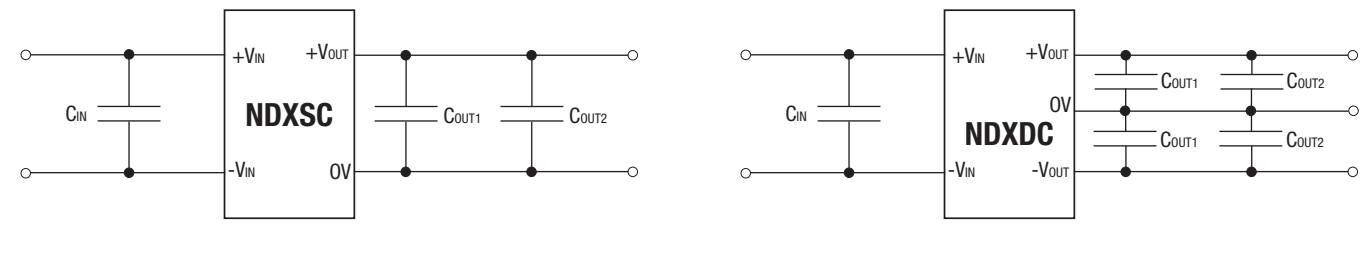

Control Pin

Dual Output: This provides an OFF function, which puts the converter into a low power mode. When the pin is high the converter is OFF. Standard TTL levels can be used but the maximum high level must not exceed 7.0V. The pin can be left open for normal operation or at voltage below 0.8V with respect to the -V_{IN} pin.
Single Output: As per dual output, however a series diode must be fitted when the control pin is used on the single output variants. Recommended diode 1N4148 or similar (direction of fitting is cathode to control pin).

Cross Regulation

Load regulation is at its best when the positive and negative loads are balanced. When the loads are asymmetric, the negative output is not as tightly regulated as the positive output. To meet ripple specification a total minimum load of 25% full load is required, however, the NDX can be used with much lighter loading at the expense of increased ripple. A small load of 150mW is required on the negative output to ensure the maximum negative output voltage is not exceeded. NDX cross regulation is defined on page 2.

Minimum load

The minimum load for correct operation is 25% of the full rated load across the specified input voltage range. Lower loads may cause a significant increase in output ripple and may cause the output voltage to exceed its specification transiently during power-down when the input voltage also falls below its rated minimum. A minimum loading of 30% load is required on NDXD4805 to prevent output voltage rise above specification during power-down.

TECHNICAL NOTES

ISOLATION VOLTAGE

'Hi Pot Test', 'Flash Tested', 'Withstand Voltage', 'Proof Voltage', 'Dielectric Withstand Voltage' & 'Isolation Test Voltage' are all terms that relate to the same thing, a test voltage, applied for a specified time, across a component designed to provide electrical isolation, to verify the integrity of that isolation.

Murata Power Solutions NDX series of DC/DC converters are all 100% production tested at their stated isolation voltage. This is 1kVDC for 1 second.

A question commonly asked is, "What is the continuous voltage that can be applied across the part in normal operation?"

For a part holding no specific agency approvals, such as the NDX series, both input and output should normally be maintained within SELV limits i.e. less than 42.4V peak, or 60VDC. The isolation test voltage represents a measure of immunity to transient voltages and the part should never be used as an element of a safety isolation system. The part could be expected to function correctly with several hundred volts offset applied continuously across the isolation barrier; but then the circuitry on both sides of the barrier must be regarded as operating at an unsafe voltage and further isolation/insulation systems must form a barrier between these circuits and any user-accessible circuitry according to safety standard requirements.

REPEATED HIGH-VOLTAGE ISOLATION TESTING

It is well known that repeated high-voltage isolation testing of a barrier component can actually degrade isolation capability, to a lesser or greater degree depending on materials, construction and environment. The NDX series has an EI ferrite core, with no additional insulation between primary and secondary windings of enameled wire. While parts can be expected to withstand several times the stated test voltage, the isolation capability does depend on the wire insulation. Any material, including this enamel (typically polyurethane) is susceptible to eventual chemical degradation when subject to very high applied voltages thus implying that the number of tests should be strictly limited. We therefore strongly advise against repeated high voltage isolation testing, but if it is absolutely required, that the voltage be reduced by 20% from specified test voltage.

This consideration equally applies to agency recognized parts rated for better than functional isolation where the wire enamel insulation is always supplemented by a further insulation system of physical spacing or barriers.

CHARACTERISATION TEST METHODS

Ripple & Noise Characterisation Method

Ripple and noise measurements are performed with the following test configuration with the inclusion of recommended input and output capacitors.

C1	1µF X7R multilayer ceramic capacitor, voltage rating to be a minimum of 3 times the output voltage of the DC/DC converter
C2	10µF tantalum capacitor, voltage rating to be a minimum of 1.5 times the output voltage of the DC/DC converter with an ESR of less than 100mΩ at 100 kHz
C3	100nF multilayer ceramic capacitor, general purpose
R1	450Ω resistor, carbon film, +/-1% tolerance
R2	50Ω BNC termination
T1	3T of the coax cable through a ferrite toroid
RLOAD	Resistive load to the maximum power rating of the DC/DC converter. Connections should be made via twisted wires

Measured values are multiplied by 10 to obtain the specified values.

Differential Mode Noise Test Schematic

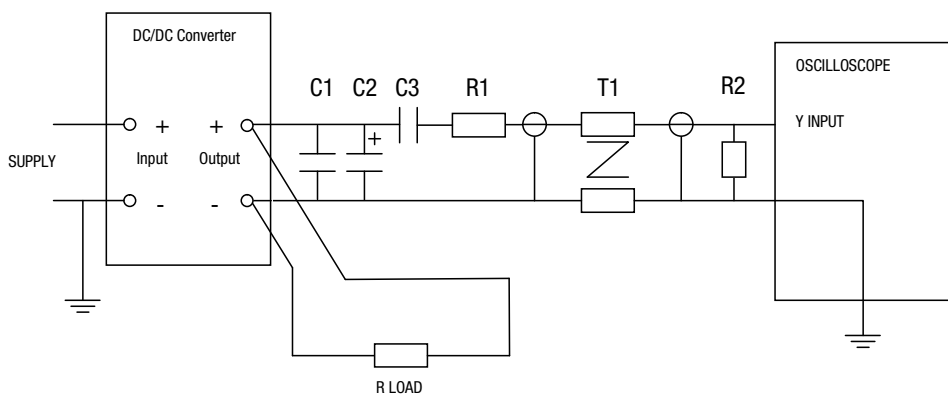

Input Reflected Ripple Current Test Method

Input reflected ripple current measurements are performed with the following test configuration with the inclusion of recommended input and output capacitors.

C1	220uF with ESR of <0.1Ω at 100kHz, rated at supply voltage
L1	12uH rated at 150% minimum of the DC current taken by the converter.
C2	The recommended input capacitor for the DC/DC converter.

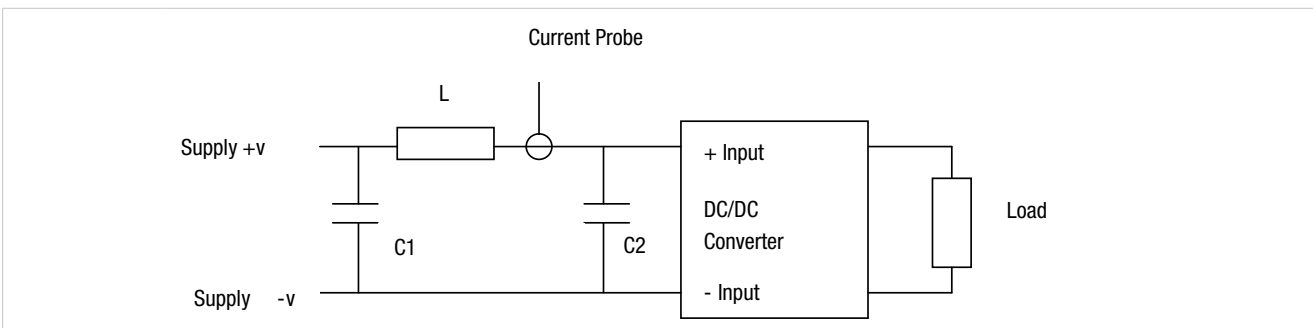

PACKAGE SPECIFICATIONS

MECHANICAL DIMENSIONS

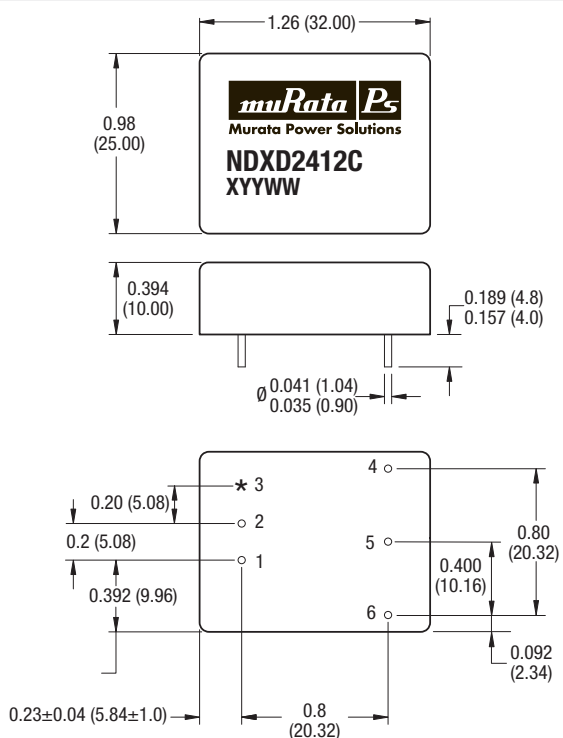

* Optional pin
 All dimensions in inches ± 0.010 (mm 0.25mm) except where stated otherwise.
 All pins on a 0.100 (2.54) pitch and within 0.010 (0.25) of true position.
 The copper case is connected to the output (-V_{OUT}) pin. Care is needed in the design of this circuit board on which the converter is mounted. Top side tracks must not contact the edge of the case on the underside of the unit.
 Please note that from 2010 onwards you may receive either a blue or a black case finish.

Weight: 20g

PIN CONNECTIONS

Pin	Function	
	Duals	Singles
1	-V _{IN}	-V _{IN}
2	+V _{IN}	+V _{IN}
3*	CTRL	CTRL
4	+V _{OUT}	+V _{OUT}
5	OV	No pin
6	-V _{OUT}	OV

* Optional pin

RECOMMENDED FOOTPRINT DETAILS

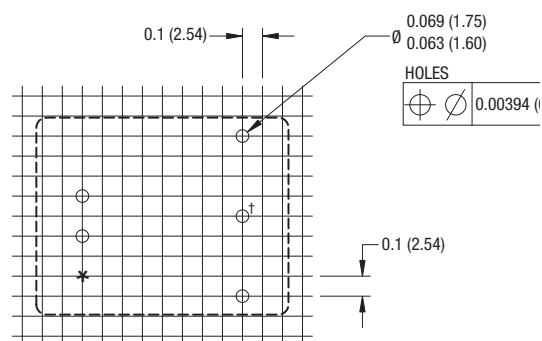

† Hole not required for single output variants.
 All dimensions in inches ± 0.010 (mm 0.25mm).

TUBE OUTLINE DIMENSIONS

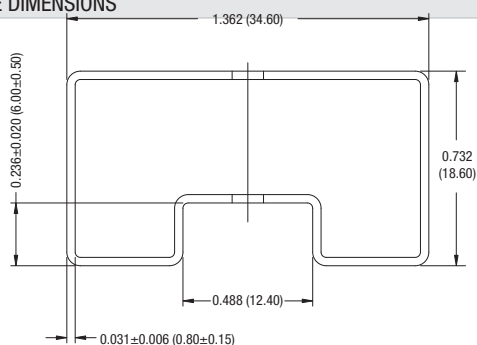

All dimensions in inches ± 0.010 (mm 0.25mm).

Quantity: 15