



Chipsmall Limited consists of a professional team with an average of over 10 year of expertise in the distribution of electronic components. Based in Hongkong, we have already established firm and mutual-benefit business relationships with customers from,Europe,America and south Asia,supplying obsolete and hard-to-find components to meet their specific needs.

With the principle of “Quality Parts,Customers Priority,Honest Operation,and Considerate Service”,our business mainly focus on the distribution of electronic components. Line cards we deal with include Microchip,ALPS,ROHM,Xilinx,Pulse,ON,Everlight and Freescale. Main products comprise IC,Modules,Potentiometer,IC Socket,Relay,Connector.Our parts cover such applications as commercial,industrial, and automotives areas.

We are looking forward to setting up business relationship with you and hope to provide you with the best service and solution. Let us make a better world for our industry!



Contact us

Tel: +86-755-8981 8866 Fax: +86-755-8427 6832

Email & Skype: info@chipsmall.com Web: www.chipsmall.com

Address: A1208, Overseas Decoration Building, #122 Zhenhua RD., Futian, Shenzhen, China



NE5550234-EV09-A

Evaluation Board

- Circuit Description
- Typical Performance Data
- Circuit Schematic and Assembly Drawing

Circuit Description

The NE5550234-EV09-A is an evaluation circuit board for Renesas' LDMOS power FET, NE5550234 optimized for the performance at 915MHz. The circuit board is RoHS compliant.

Matching and Bias Circuits

Refer to the schematic and assembly drawing in the two last pages for the component designation and location.

The input matching circuit consists of two sections of low pass network. An inductor, L1 and a section of transmission line, TL4 are the serial components in the network. At output, three sections of transmission line, TL1, TL2 and TL3 provide the required serial components for the impedance transformation. The performance is most sensitive to the length of TL1 and not very sensitive to TL3. The electrical lengths of the transmission lines labeled on the schematic are estimated and for reference only. Some bench tuning on the actual circuit board is usually required to achieve an optimal performance. For applications where there is a constraint on the board space, serial inductors, instead of transmission lines, can be used for the matching circuits. Low loss inductors should be selected to maintain good efficiency of the PA circuit. The resistor, R3(=2.4ohm) at input is used to improve the stability margin. The gain is reduced by about 1-2dB when R3 is used.

LDMOSFETs essentially draw no gate current under normal operation conditions. Therefore a large value resistor, in the order of k Ω , can be used for the bias at gate so that the RF path is completely isolated from the DC line. At the drain an inductor is used as the RF choke. The current rating for this inductor should be high enough to provide the required current at the operation conditions.

Bias Conditions

This evaluation board was optimized at a specific drain voltage, 7.5V. For different supply voltages, the matching circuits should be adjusted to fully utilize the device capability. The quiescent current is 40mA for the data shown below. The gain is higher at higher quiescent currents, particularly when the device is not completely saturated. For many communication systems, where the PA is never at idle state, a high quiescent current might be used.

PCB Material:

The PCB is Getek 28mil two layer board. The dielectric constant of Getek is 4.2.

Typical Performance Data

Test Conditions:

f=915MHz

Vd=7.5V, Idsq=40mA

Pout, Gain, PAE and Current vs Pin are shown in the following plot.

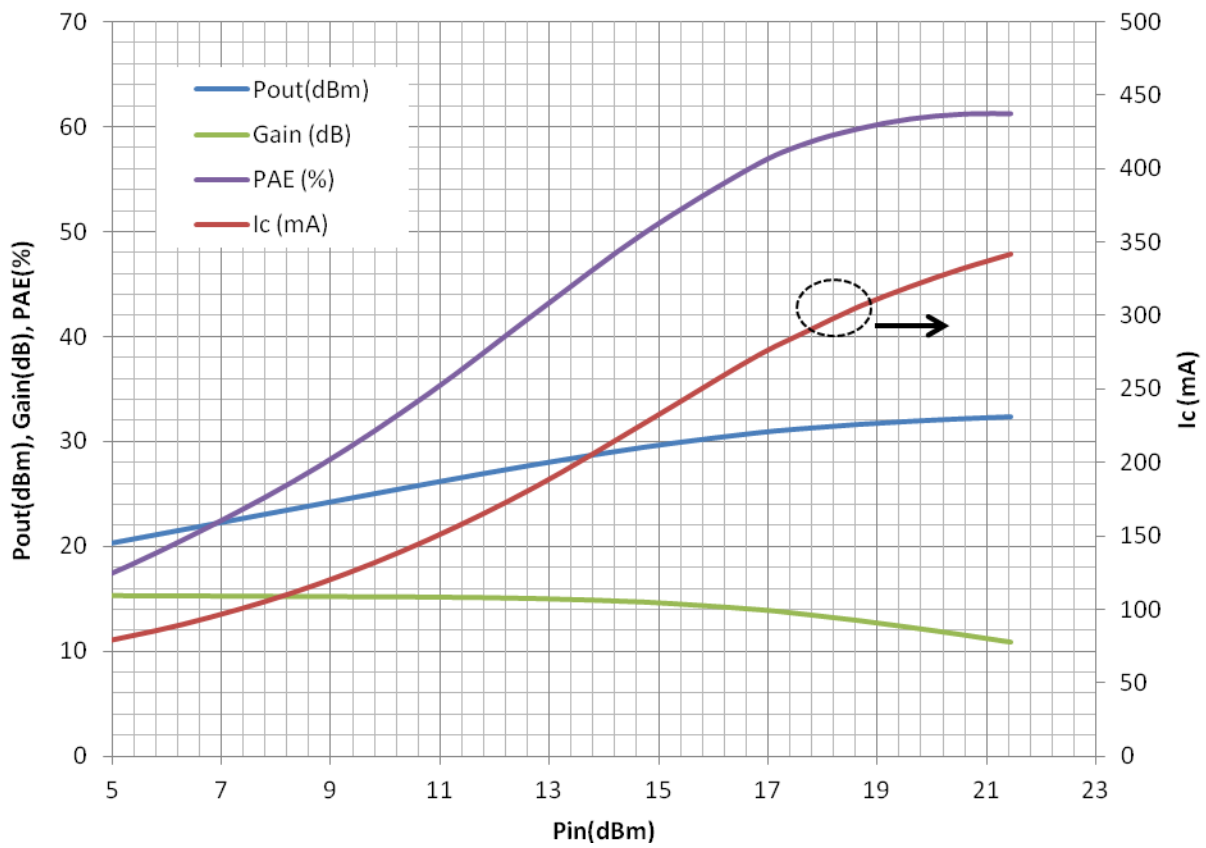

REVISIONS				
ZONE	LTR	DESCRIPTION	DATE	APPROVED

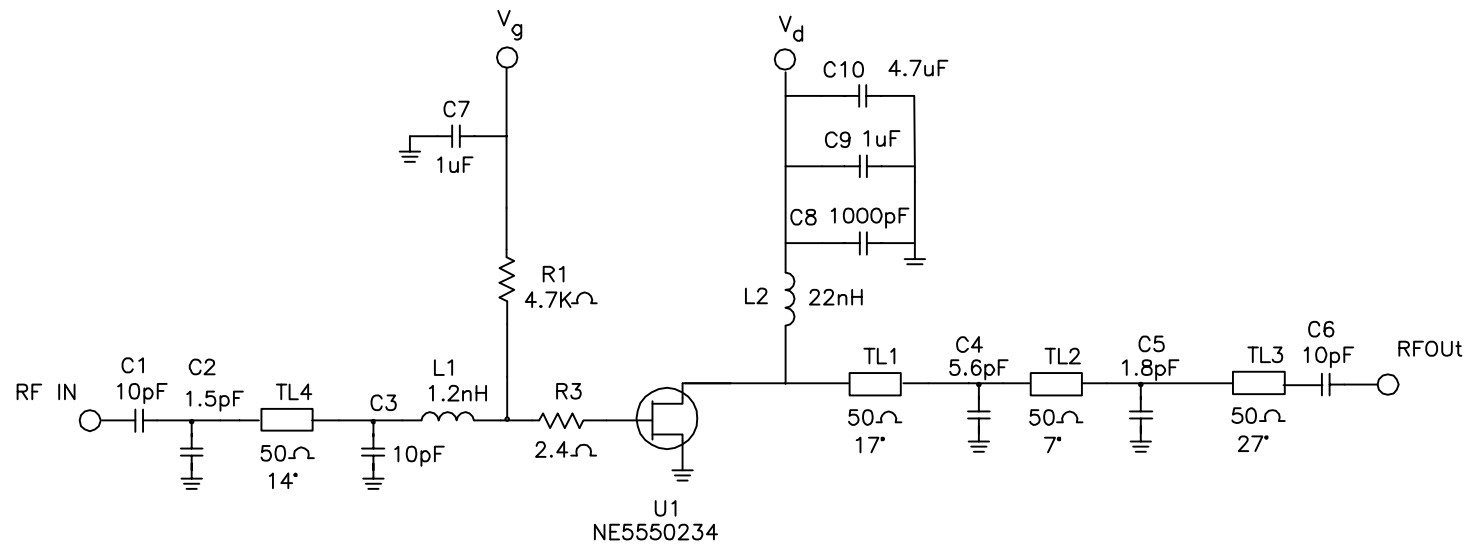

Note: All electrical lengths are at 915MHz

QTY	PART OR IDENTIFYING NO.	NOMENCLATURE OR DESCRIPTION	MATERIAL/SPECIFICATION	ITEM NO.
1	TF-101642		BLOCK	17
1	267M1002475K	C10	4.7uF 10V TANT CHIP CAP b MATS	16
1	GRM1885C1H102JA01	C8	0603 1000pF CAP MURATA	15
2	GRM185R61C105KE44	C7,C9	0603 1uF CAP MURATA	14
1	GRM1885C1HIR8DZ01	C5	0603 1.8pF CAP MURATA	13
1	GRM1885C1H5R6JA01	C4	0603 5.6pF CAP MURATA	12
1	GRM1885C1HIR5DZ01	C2	0603 1.5pF CAP MURATA	11
3	GRM1885C1H100JA01	C1,C3,C6	0603 10pF CAP MURATA	10
1	GENERIC	R3	0603 2.4 OHM RES	9
1	GENERIC	R2	0603 0 OHM RES	8
1	GENERIC	R1	0603 4.7 KOHM RES	7
1	LQW18AN22NG00	L2	0603 22nH IND WIRE WOUND MURATA	6
2	LQG18HN1N2S00	L1	0603 1.2nH IND MURATA	5
3	1205-003	P1, P2, P3	FEEDTHRU MURATA	4
2	142-0701-841	J1, J2	SMA FEMALE CONNECTOR E.F. JOHNSON	3
1	NE5550234	U1	IC RENESAS	2
1	CL-102046	PCB	COMPONENT LAYOUT DRAWING	1

UNLESS OTHERWISE SPECIFIED DIMENSIONS ARE IN INCHES TOLERANCES		APPROVALS		CALIFORNIA EASTERN LABS 4590 PATRICK HENRY DR. SANTA CLARA CA. 95054 TITLE: NE5550234-EV09-A SCHEMATIC AND BOM	
DECIMALS .XX± .01	ANGULAR ± 1°	Drawing by:	8/16/2012		
DO NOT SCALE DRAWING		Designed by:	8/16/2012		
MATERIAL		Checked by:			
FINISH		Project Engineer:			
NEXT ASSY	USED ON	Quality Control:			
APPLICATION				SIZE	FSCM NO.
				C	
				DWG NO.	
				AD102066	
				SCALE NONE	RELEASE DATE
				PROTOTYPE	SHEET 1 OF 1

REV
—

REVISIONS				
ZONE	LTR	DESCRIPTION	DATE	APPROVED

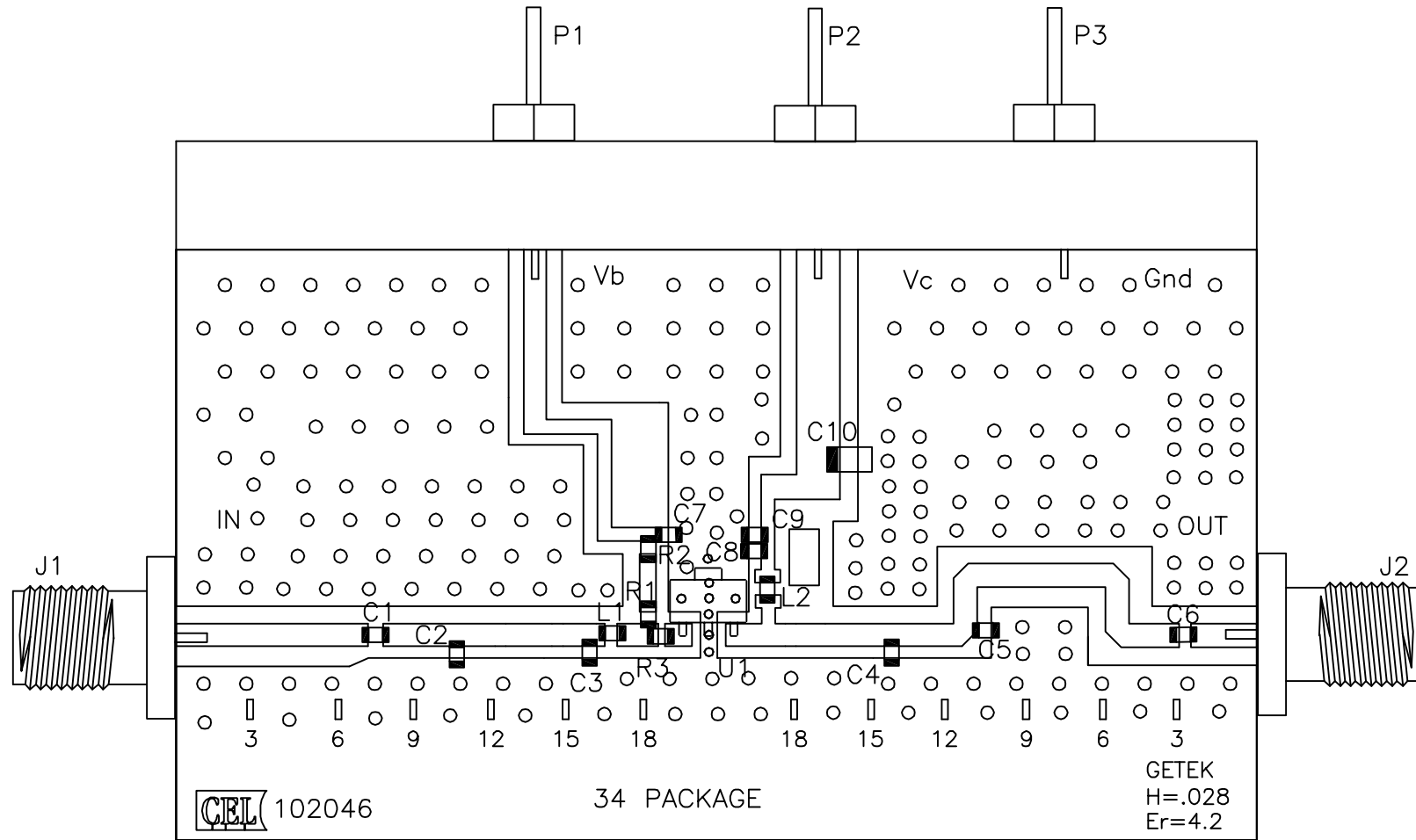

UNLESS OTHERWISE SPECIFIED DIMENSIONS ARE IN INCHES TOLERANCES		APPROVALS		CALIFORNIA EASTERN LABS 4590 PATRICK HENRY DR. SANTA CLARA CA. 95054	
DECIMALS .XX± .01	ANGULAR ± 1°	Drawing by:	M Dong	TITLE:	
.XXX± .005	DO NOT SCALE DRAWING	Designed by:	M Dong	NE5550234-EV09-A	
MATERIAL		Checked by:		LAYOUT	
FINISH		Project Engineer:		SIZE	FSCM NO.
NEXT ASSY	USED ON	Quality Control:		C	
APPLICATION				DWG NO.	AD102066
				SCALE NONE	RELEASE DATE PROTOTYPE SHEET 1 OF 1