



Chipsmall Limited consists of a professional team with an average of over 10 year of expertise in the distribution of electronic components. Based in Hongkong, we have already established firm and mutual-benefit business relationships with customers from,Europe,America and south Asia,supplying obsolete and hard-to-find components to meet their specific needs.

With the principle of "Quality Parts,Customers Priority,Honest Operation,and Considerate Service",our business mainly focus on the distribution of electronic components. Line cards we deal with include Microchip,ALPS,ROHM,Xilinx,Pulse,ON,Everlight and Freescale. Main products comprise IC,Modules,Potentiometer,IC Socket,Relay,Connector.Our parts cover such applications as commercial,industrial, and automotives areas.

We are looking forward to setting up business relationship with you and hope to provide you with the best service and solution. Let us make a better world for our industry!



Contact us

Tel: +86-755-8981 8866 Fax: +86-755-8427 6832

Email & Skype: info@chipsmall.com Web: www.chipsmall.com

Address: A1208, Overseas Decoration Building, #122 Zhenhua RD., Futian, Shenzhen, China



NE5550234

Data Sheet
R09DS0039EJ0300
Rev.3.00
Mar 12, 2013

Silicon Power MOS FET

FEATURES

- High Output Power : $P_{out} = 33.0$ dBm TYP. ($V_{DS} = 7.5$ V, $I_{Dset} = 40$ mA, $f = 460$ MHz, $P_{in} = 15$ dBm)
- High power added efficiency : $\eta_{add} = 68\%$ TYP. ($V_{DS} = 7.5$ V, $I_{Dset} = 40$ mA, $f = 460$ MHz, $P_{in} = 15$ dBm)
- High Linear gain : $G_L = 23.5$ dB TYP. ($V_{DS} = 7.5$ V, $I_{Dset} = 40$ mA, $f = 460$ MHz, $P_{in} = 0$ dBm)
- High ESD tolerance
- Suitable for VHF to UHF-BAND Class-AB power amplifier.

APPLICATIONS

- 150 MHz Band Radio System
- 460 MHz Band Radio System
- 900 MHz Band Radio System

ORDERING INFORMATION

Part Number	Order Number	Package	Marking	Supplying Form
NE5550234	NE5550234-AZ	3-pin power minimold (34 PKG) (Pb-Free)	V5	<ul style="list-style-type: none"> • 12 mm wide embossed taping • Gate pin faces the perforation side of the tape
NE5550234-T1	NE5550234-T1-AZ			<ul style="list-style-type: none"> • 12 mm wide embossed taping • Gate pin faces the perforation side of the tape • Qty 1 kpcs/reel

Remark To order evaluation samples, please contact your nearby sales office.
Part number for sample order: NE5550234-AZ

ABSOLUTE MAXIMUM RATINGS ($T_A = 25^\circ\text{C}$, unless otherwise specified)

Operation in excess of any one of these parameters may result in permanent damage.

Parameter	Symbol	Ratings	Unit
Drain to Source Voltage	V_{DS}	30	V
Gate to Source Voltage	V_{GS}	6.0	V
Drain Current	I_{DS}	0.6	A
Drain Current (50% Duty Pulsed)	$I_{DS-pulse}$	1.2	A
Total Power Dissipation ^{Note}	P_{tot}	12.5	W
Channel Temperature	T_{ch}	150	$^\circ\text{C}$
Storage Temperature	T_{stg}	-65 to +150	$^\circ\text{C}$

Note: Value at $T_C = 25^\circ\text{C}$

CAUTION

Observe precautions when handling because these devices are sensitive to electrostatic discharge.

The mark <R> shows major revised points.

The revised points can be easily searched by copying an "<R>" in the PDF file and specifying it in the "Find what:" field.

RECOMMENDED OPERATING RANGE ($T_A = 25^\circ\text{C}$)

Parameter	Symbol	Test Conditions	MIN.	TYP.	MAX.	Unit
Drain to Source Voltage	V_{DS}		–	7.5	9.0	V
Gate to Source Voltage	V_{GS}		1.65	2.20	2.85	V
Drain Current	I_{DS}		–	0.38	–	A
Input Power	P_{in}	$f = 460\text{ MHz}, V_{DS} = 7.5\text{ V}$	–	15	20	dBm

ELECTRICAL CHARACTERISTICS ($T_A = 25^\circ\text{C}$, unless otherwise specified)

Parameter	Symbol	Test Conditions	MIN.	TYP.	MAX.	Unit
DC Characteristics						
Gate to Source Leakage Current	I_{GSS}	$V_{GS} = 6.0\text{ V}$	–	–	100	nA
Drain to Source Leakage Current (Zero Gate Voltage Drain Current)	I_{DSS}	$V_{DS} = 25\text{ V}$	–	–	10	μA
Gate Threshold Voltage	V_{th}	$V_{DS} = 7.5\text{ V}, I_{DS} = 1.0\text{ mA}$	1.15	1.65	2.25	V
Drain to Source Breakdown Voltage	BV_{DSS}	$I_{DS} = 10\ \mu\text{A}$	25	38	–	V
Transconductance	G_m	$V_{DS} = 7.5\text{ V}, I_{DS} = 140\pm 20\text{ mA}$	–	0.44	–	S
Thermal Resistance	R_{th}	Channel to Case	–	10.0	–	$^\circ\text{C/W}$
RF Characteristics						
Output Power	P_{out}	$f = 460\text{ MHz}, V_{DS} = 7.5\text{ V},$	31.5	33.0	–	dBm
Drain Current	I_{DS}	$P_{in} = 15\text{ dBm},$	–	0.38	–	A
Power Drain Efficiency	η_d	$I_{Dset} = 40\text{ mA (RF OFF)}$	–	70	–	%
Power Added Efficiency	η_{add}		–	68	–	%
Linear Gain	G_L ^{Note 1}		–	23.5	–	dB
Load VSWR Tolerance	^{Note 2}	$f = 460\text{ MHz}, V_{DS} = 9.0\text{ V},$ $P_{in} = 15\text{ dBm},$ $I_{Dset} = 40\text{ mA (RF OFF)}$ Load VSWR=20:1(All Phase)	No Destroy			
Output Power	P_{out}	$f = 157\text{ MHz}, V_{DS} = 7.5\text{ V},$	–	33.0	–	dBm
Drain Current	I_{DS}	$P_{in} = 15\text{ dBm},$	–	0.36	–	A
Power Drain Efficiency	η_d	$I_{Dset} = 40\text{ mA (RF OFF)}$	–	74	–	%
Power Added Efficiency	η_{add}		–	73	–	%
Linear Gain	G_L ^{Note 3}		–	25.8	–	dB
Output Power	P_{out}	$f = 900\text{ MHz}, V_{DS} = 7.5\text{ V},$	–	32.2	–	dBm
Drain Current	I_{DS}	$P_{in} = 17\text{ dBm},$	–	0.35	–	A
Power Drain Efficiency	η_d	$I_{Dset} = 40\text{ mA (RF OFF)}$	–	62	–	%
Power Added Efficiency	η_{add}		–	60	–	%
Linear Gain	G_L ^{Note 4}		–	18.3	–	dB

Notes: 1. $P_{in} = 0\text{ dBm}$

2. These characteristics values are measurement using measurement tools especially by RENESAS.

3. $P_{in} = -5\text{ dBm}$

4. $P_{in} = 7\text{ dBm}$

Remark DC performance is 100% testing. RF performance is testing several samples per wafer.

The wafer rejection criterion for standard devices is 1 reject for several samples.

TEST CIRCUIT SCHEMATIC FOR 460 MHz

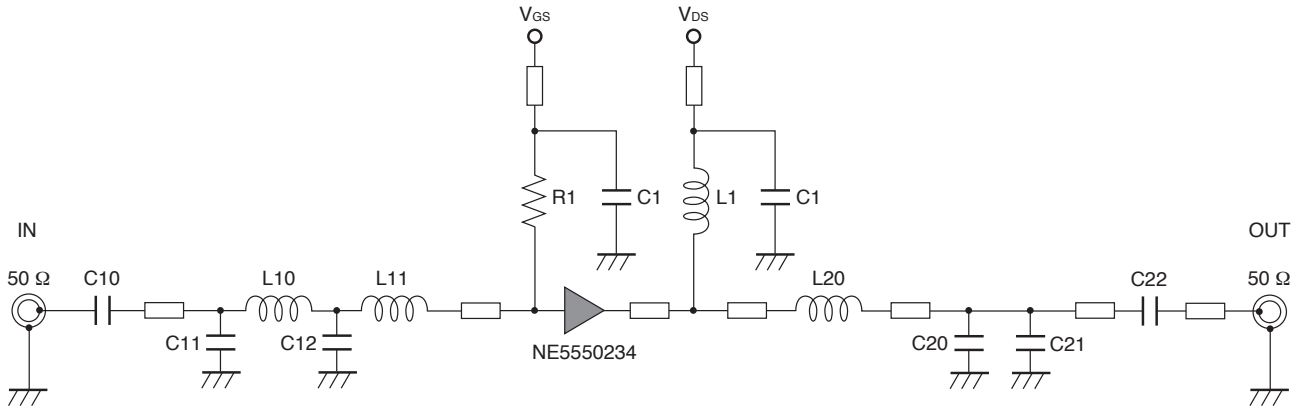

COMPONENTS OF TEST CIRCUIT FOR MEASURING ELECTRICAL CHARACTERISTICS

Symbol	Value	Type	Maker
C1	1 μ F	GRM31MR71H105KA88L	Murata
C10	27 pF	GRM1882C1H270JA01	Murata
C11	3.9 pF	GRM1882C1H3R9CZ01	Murata
C12	18 pF	GRM1882C1H180JA01	Murata
C20	12 pF	GRM1882C1H120JA01	Murata
C21	1.5 pF	GRM1882C1H1R5CZ01	Murata
C22	100 pF	GRM2162C1H101JA01D	Murata
R1	4.7 k Ω	1/10 W Chip Resistor SSM_RG1608PB472	SSM
L1	47.2 nH	ϕ 0.4 mm, ϕ D = 2 mm, 7 Turns	Ohesangyou
L10, L11	12 nH	LL1608-FS12NJ	TOKO
L20	7.8 nH	ϕ 0.4 mm, ϕ D = 1.4 mm, 3 Turns	Ohesangyou
PCB	-	R1766, t = 0.8 mm, ϵ = 4.8, size = 30 x 40 mm	Panasonic
SMA Connector	-	WAKA 01K0790-20	WAKA

<R>

COMPONENT LAYOUT OF TEST CIRCUIT FOR 460 MHz

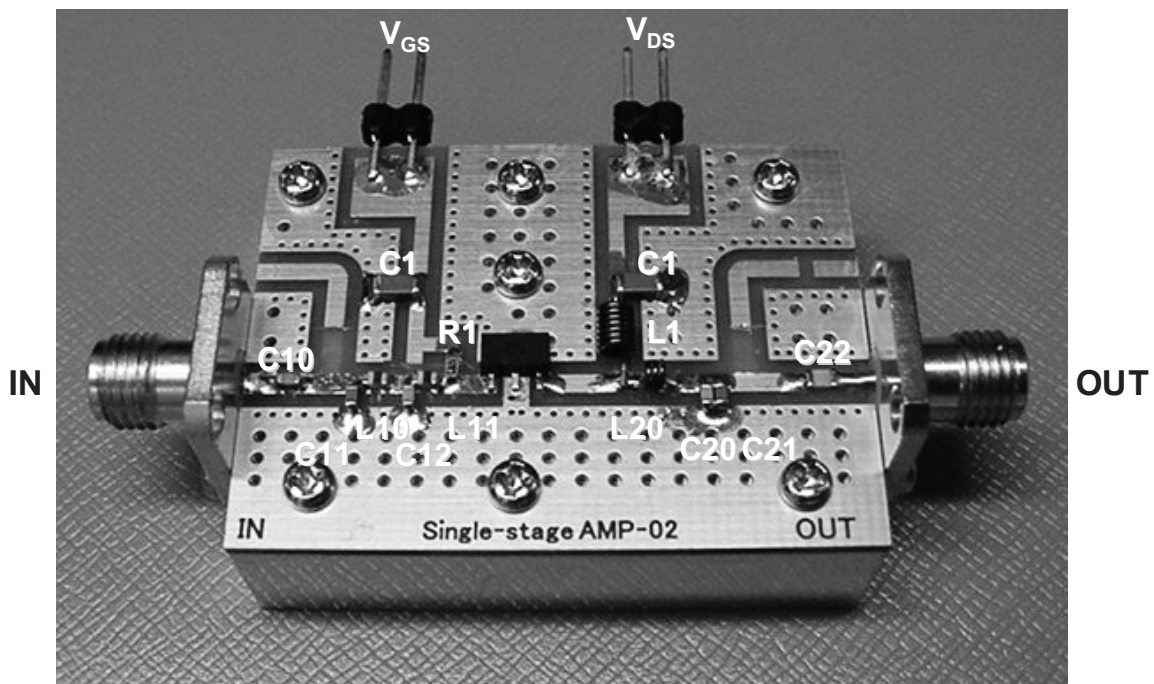

TYPICAL CHARACTERISTICS 1 (T_A = 25°C)

RF: f = 460MHz, V_{DS} = 3.6/4.5/6/7.5/9 V, I_{Dset} = 40 mA, P_{in} = -15 to 20 dBm

IM: f1 = 460MHz, f2 = 461 MHz, V_{DS} = 3.6/4.5/6/7.5/9 V, I_{Dset} = 40mA, P_{out} (2 tone) = 6 to 28 dBm

OUTPUT POWER, DRAIN CURRENT vs. INPUT POWER

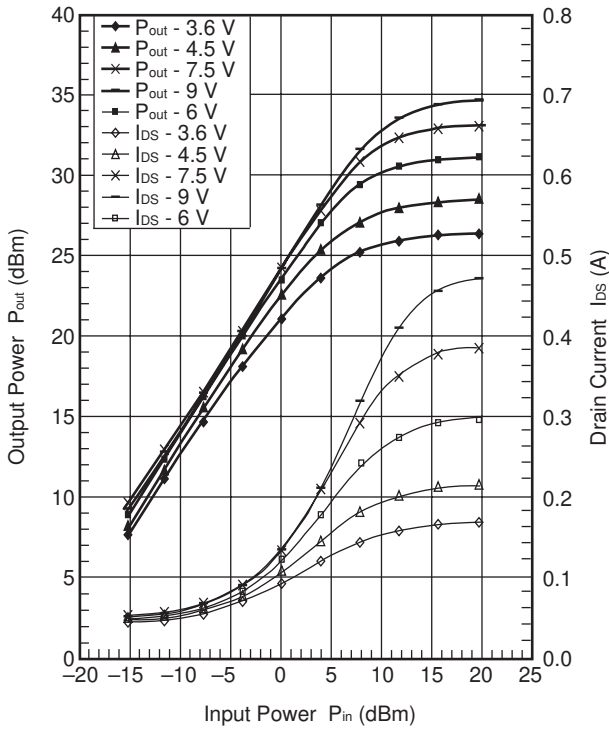

POWER GAIN, POWER ADDED EFFICIENCY vs. INPUT POWER

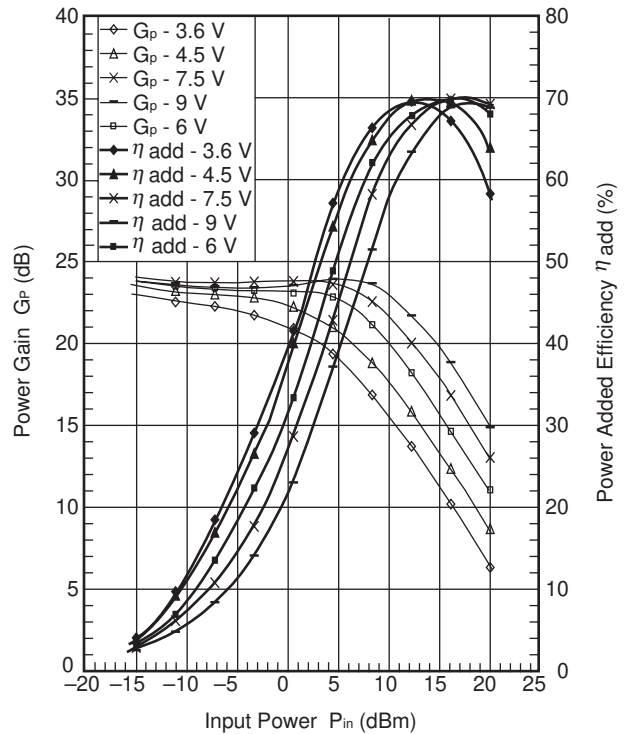

2f₀, 3f₀ vs. OUTPUT POWER

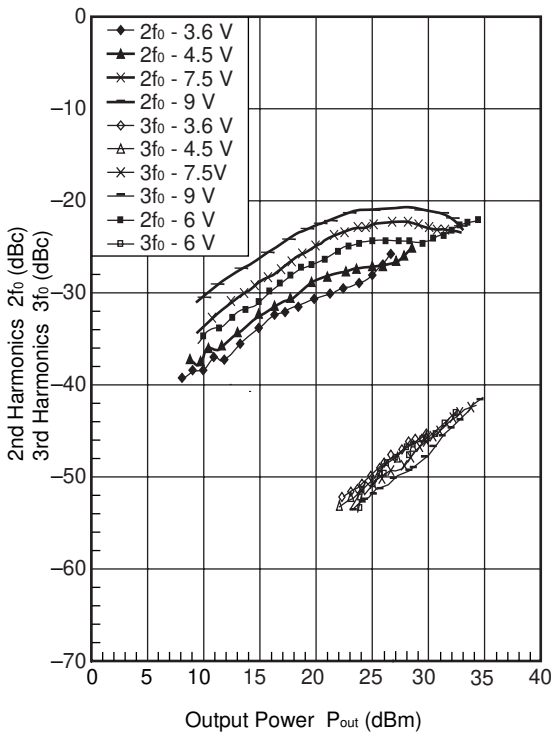

IM₃/IM₅ vs. 2 TONES OUTPUT POWER

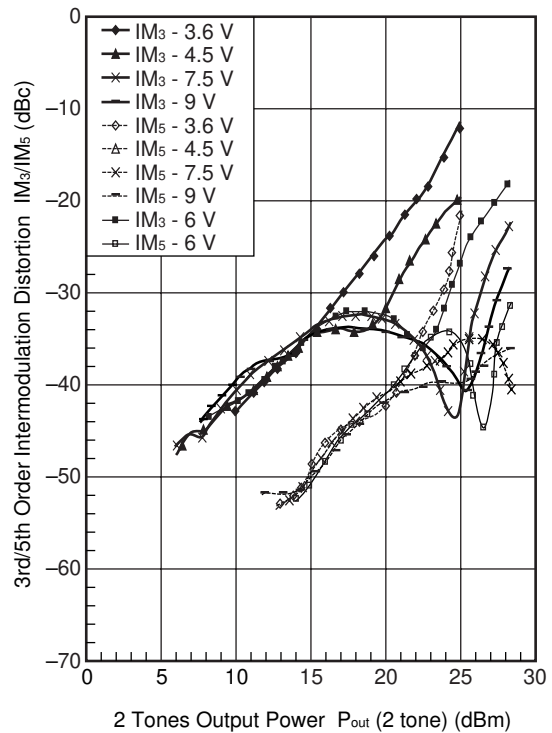

Remark The graphs indicate nominal characteristics.

TEST CIRCUIT SCHEMATIC FOR 157 MHz

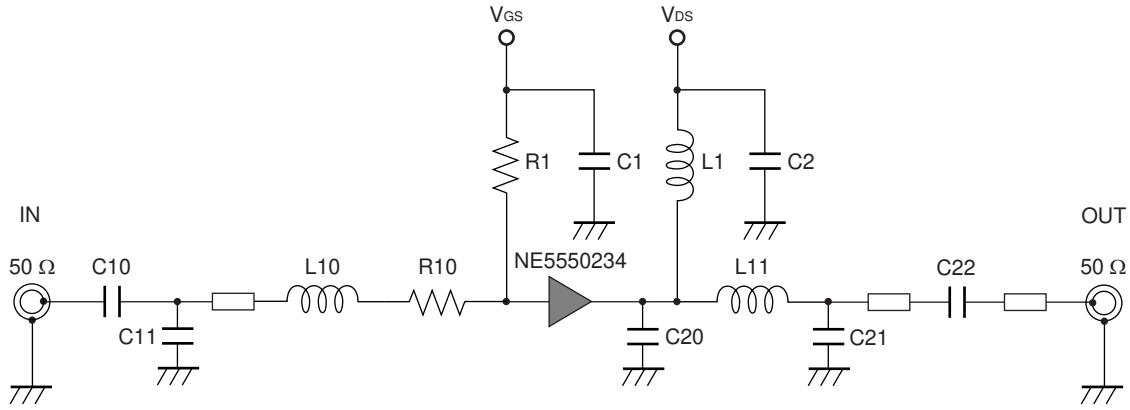

COMPONENTS OF TEST CIRCUIT FOR MEASURING ELECTRICAL CHARACTERISTICS

Symbol	Value	Type	Maker	
C10	27 pF	GQM1882C1H270JB01	Murata	
C11	6.8 pF	GQM1882C1H6R8DB01	Murata	
C20	8.2 pF	GQM1882C1H8R2DB01	Murata	
C21	27 pF	GQM1882C1H270JB01	Murata	
C22	100 pF	GQM1882C1H101JB01	Murata	
C1	1 μ F	GRM21BB31H105KA2L	Murata	
C2	1 μ F	GRM21BB31H105KA2L	Murata	
L10	100 nH	LL1608-FSLR10J	Toko	
L11	47 nH	D20-47N2	Ohesangyou	
L1	74 nH	D20-74N7	Ohesangyou	
<R>	R10	5.6 Ω	MCR03J5R6	Rohm
	R1	4.7 k Ω	MCR03J472	Rohm
<R>	PCB	-	R1766, t = 0.8 mm, ϵ = 4.8, size = 30 \times 40 mm	Panasonic
	SMA Connector	-	WAKA 01K0790-20	WAKA

NE5550234

COMPONENT LAYOUT OF TEST CIRCUIT FOR 157 MHz

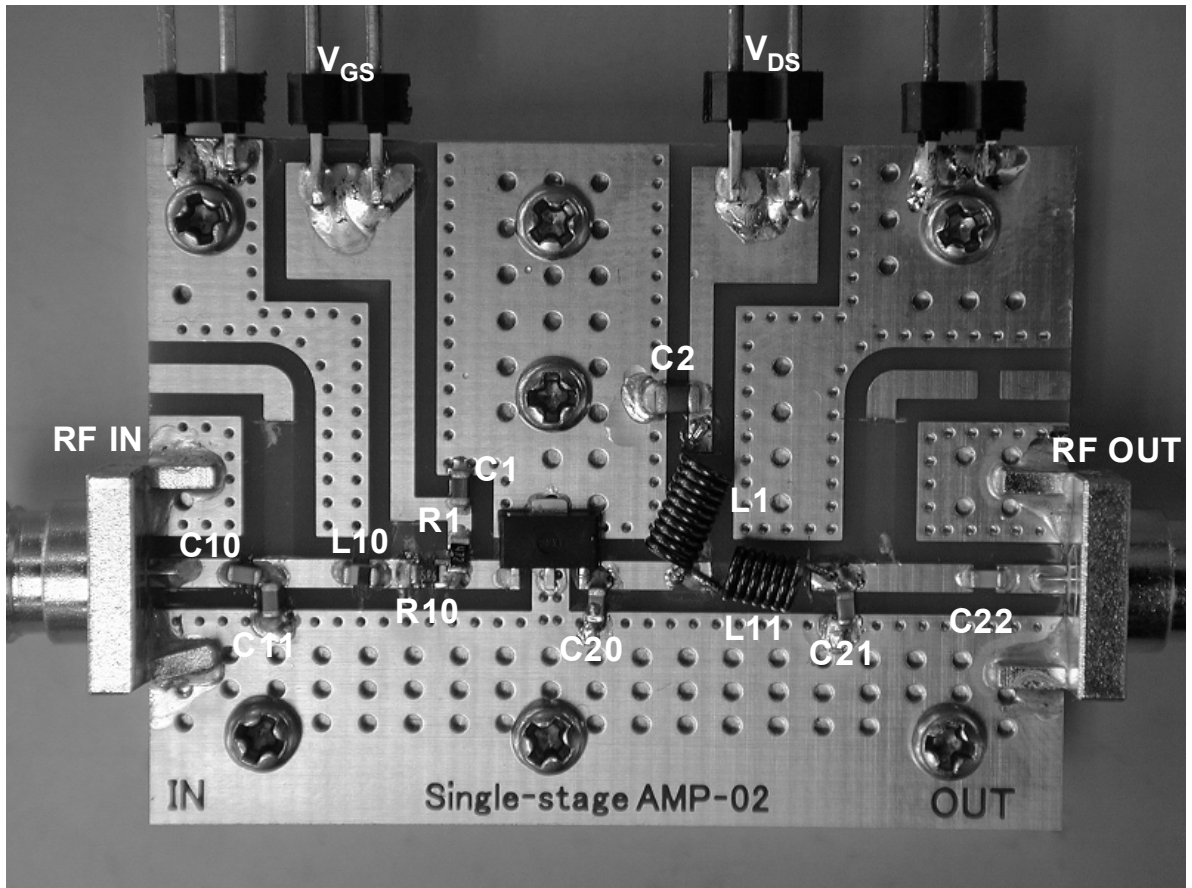

TYPICAL CHARACTERISTICS 2 ($T_A = 25^\circ\text{C}$)

RF: $f = 157\text{ MHz}$, $V_{DS} = 3.6/4.5/6/7.5/9\text{ V}$, $I_{Dset} = 40\text{ mA}$, $P_{in} = -10\text{ to }20\text{ dBm}$

OUTPUT POWER, DRAIN CURRENT vs. INPUT POWER

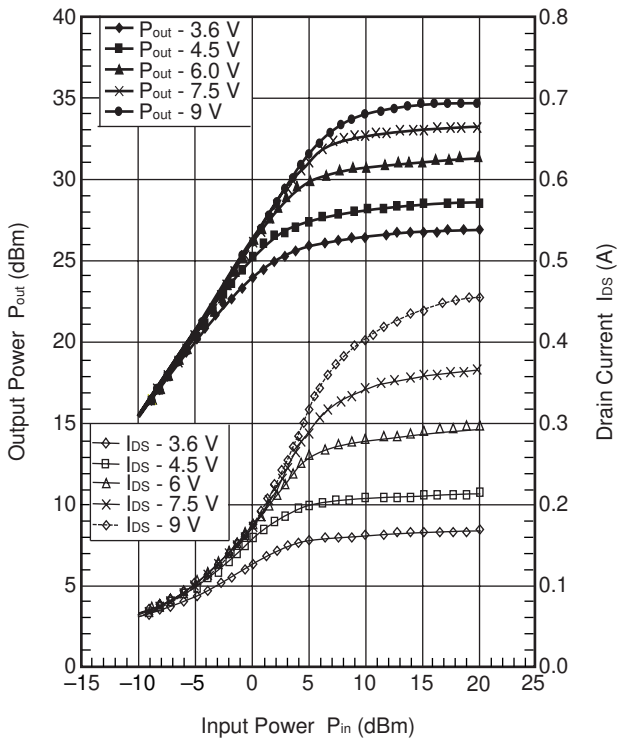

POWER GAIN, POWER ADDED EFFICIENCY vs. INPUT POWER

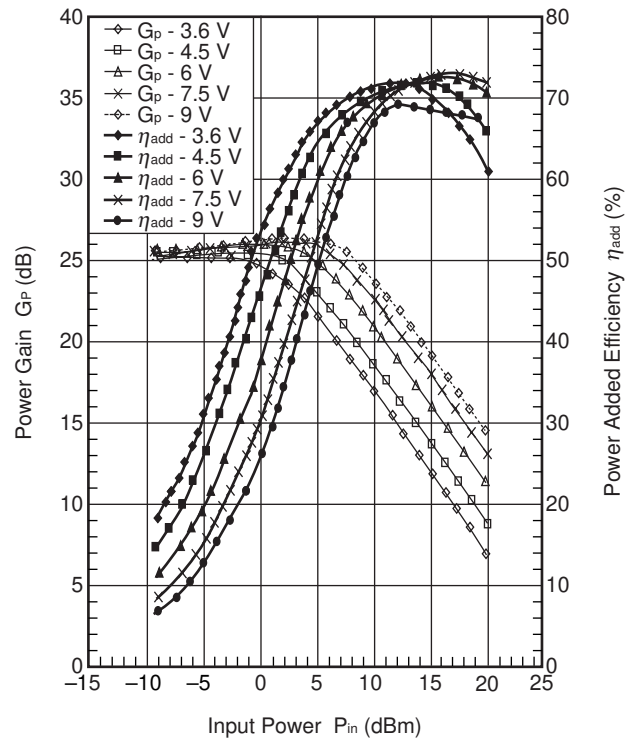

Remark The graphs indicate nominal characteristics.

TEST CIRCUIT SCHEMATIC FOR 900 MHz

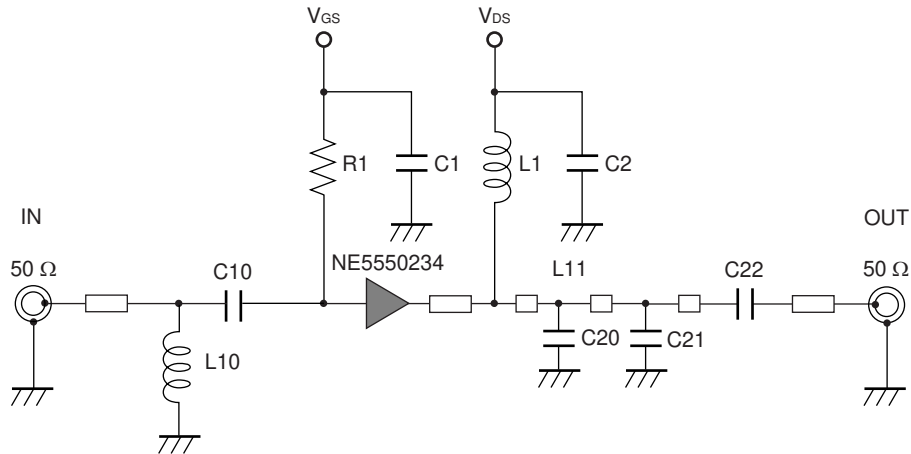

COMPONENTS OF TEST CIRCUIT FOR MEASURING ELECTRICAL CHARACTERISTICS

Symbol	Value	Type	Maker
C10	10 pF	GQM1882C1H100JB01	Murata
C20	6.8 pF	GQM1882C1H6R8DB01	Murata
C21	1 pF	GQM1884C2A1R0CB01	Murata
C22	100 pF	GQM1882C1H101JB01	Murata
C1	1 μF	GRM21BB31H105KA2L	Murata
C2	1 μF	GRM21BB31H105KA2L	Murata
L10	2.7 nH	LL1608-FSL2N7S	Toko
L1	74 nH	D20-74N7	Ohesangyou
R1	4.7 kΩ	MCR03J472	Rohm
<R> PCB	-	R1766, t = 0.8 mm, εr = 4.8, size = 30 × 40 mm	Panasonic
SMA Connector	-	WAKA 01K0790-20	WAKA

COMPONENT LAYOUT OF TEST CIRCUIT FOR 900 MHz

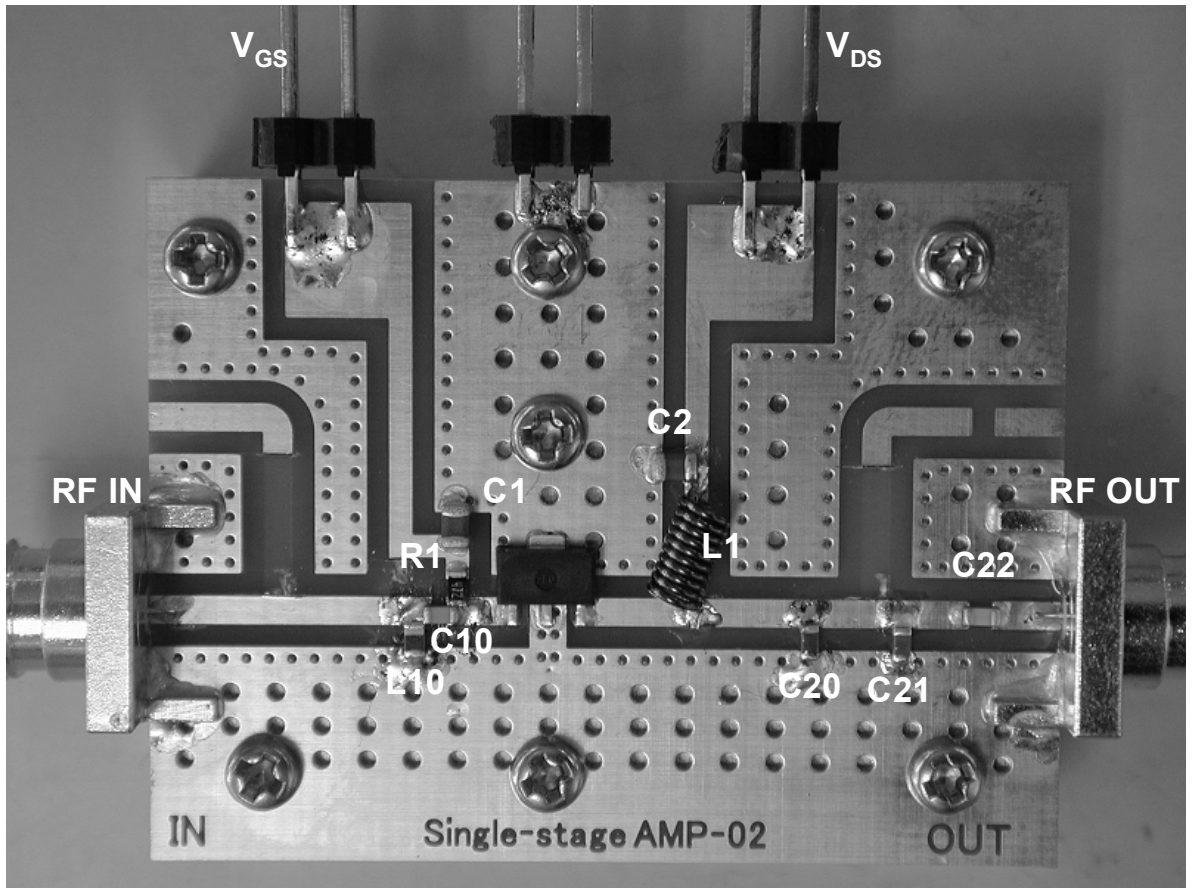

TYPICAL CHARACTERISTICS 3 ($T_A = 25^\circ\text{C}$)

RF: $f = 900\text{ MHz}$, $V_{DS} = 3.6/4.5/6/7.5/9\text{ V}$, $I_{Dset} = 40\text{ mA}$, $P_{in} = -10\text{ to }20\text{ dBm}$

OUTPUT POWER, POWER ADDED EFFICIENCY vs. INPUT POWER

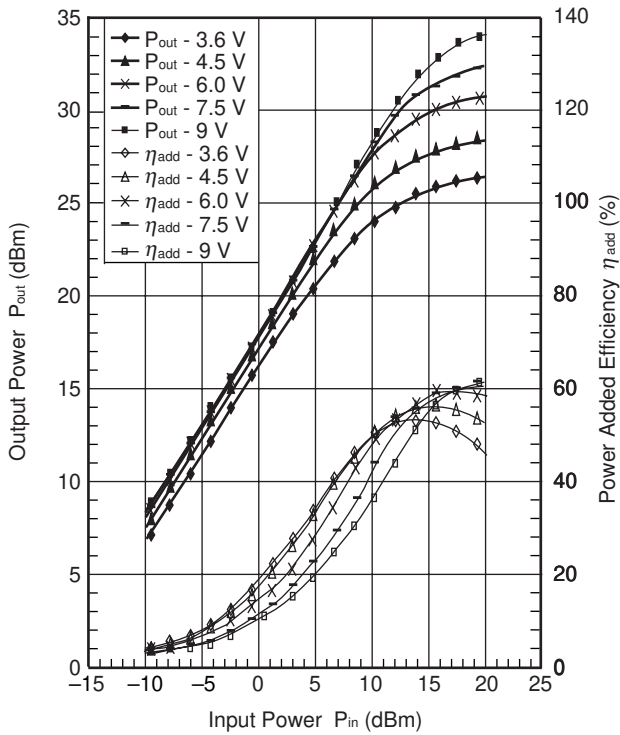

POWER GAIN, DRAIN CURRENT vs. INPUT POWER

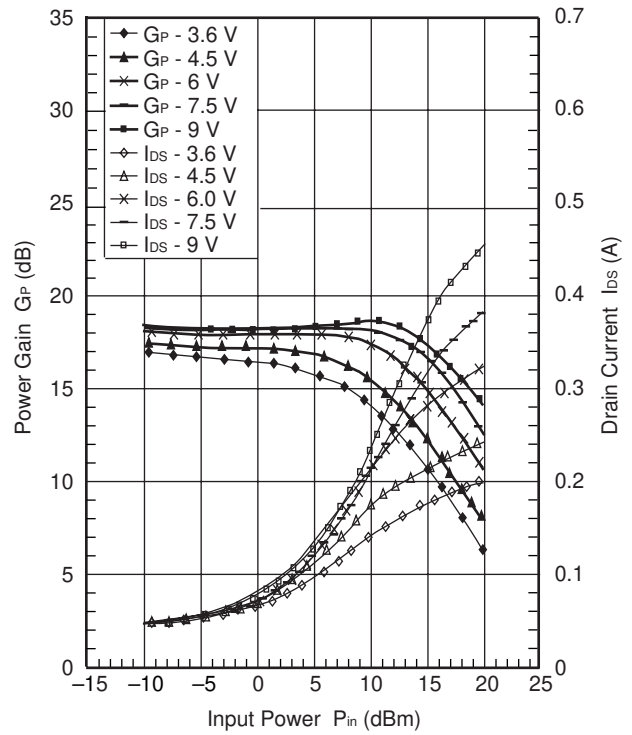

Remark The graphs indicate nominal characteristics.

S-PARAMETERS

S-parameters and noise parameters are provided on our web site in a form (S2P) that enables direct import of the parameters to microwave circuit simulators without the need for keyboard inputs.

Click here to download S-parameters.

[Products] → [RF Devices] → [Device Parameters]

URL <http://www.renesas.com/products/microwave/>

NE5550234

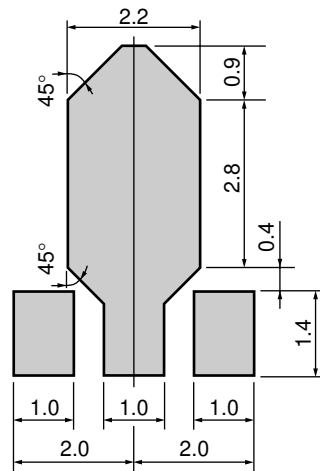
MOUNTING PAD LAYOUT DIMENSIONS**3-PIN POWER MINIMOLD (34 PKG) (UNIT: mm)**

Remark The mounting pad layout in this document is for reference only.

When designing PCB, please consider workability of mounting, solder joint reliability, prevention of solder bridge and so on, in order to optimize the design.

PACKAGE DIMENSIONS

3-PIN POWER MINIMOLD (34 PKG) (UNIT: mm)

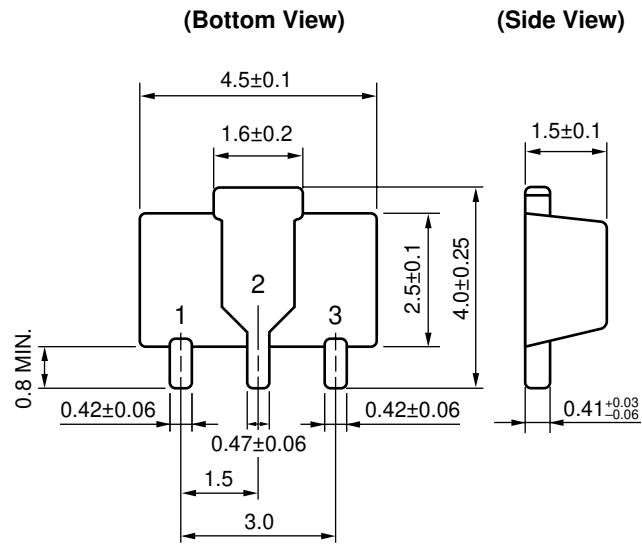

PIN CONNECTIONS

- 1. Drain
- 2. Source
- 3. Gate

Revision History	NE5550234 Data Sheet
-------------------------	-----------------------------

Rev.	Date	Description	
		Page	Summary
1.00	Apr 25, 2012	–	First edition issued
2.00	Jul 04, 2012	p.2	Modification of ELECTRICAL CHARACTERISTICS
3.00	Mar 12, 2013	P3	Modification of COMPONENTS OF TEST CIRCUIT FOR MEASURING ELECTRICAL CHARACTERISTICS
		P5	Modification of TEST CIRCUIT SCHEMATIC FOR 157 MHz
		P8	Modification of COMPONENTS OF TEST CIRCUIT FOR MEASURING ELECTRICAL CHARACTERISTICS

All trademarks and registered trademarks are the property of their respective owners.
