



Chipsmall Limited consists of a professional team with an average of over 10 year of expertise in the distribution of electronic components. Based in Hongkong, we have already established firm and mutual-benefit business relationships with customers from,Europe,America and south Asia,supplying obsolete and hard-to-find components to meet their specific needs.

With the principle of “Quality Parts,Customers Priority,Honest Operation,and Considerate Service”,our business mainly focus on the distribution of electronic components. Line cards we deal with include Microchip,ALPS,ROHM,Xilinx,Pulse,ON,Everlight and Freescale. Main products comprise IC,Modules,Potentiometer,IC Socket,Relay,Connector.Our parts cover such applications as commercial,industrial, and automotives areas.

We are looking forward to setting up business relationship with you and hope to provide you with the best service and solution. Let us make a better world for our industry!



Contact us

Tel: +86-755-8981 8866 Fax: +86-755-8427 6832

Email & Skype: info@chipsmall.com Web: www.chipsmall.com

Address: A1208, Overseas Decoration Building, #122 Zhenhua RD., Futian, Shenzhen, China



NEC

SURFACE MOUNT NPN SILICON HIGH FREQUENCY TRANSISTOR

NE687 SERIES

FEATURES

- **LOW NOISE:** 1.3 dB AT 2.0 GHz
- **LOW VOLTAGE OPERATION**
- **EASY TO MATCH**
- **HIGH GAIN BANDWIDTH PRODUCT:** ft of 13 GHz
- **AVAILABLE IN SIX LOW COST PLASTIC SURFACE MOUNT PACKAGE STYLES**

DESCRIPTION

The NE687 series of NPN epitaxial silicon transistors are designed for low cost, low noise applications. Excellent performance at low voltage/low current makes this series an ideal choice for portable wireless applications at 1.6, 1.9 and 2.4 GHz. The NE687 die is available in six different low cost plastic surface mount package styles.

 18 (SOT 343 STYLE)	 19 (3 PIN ULTRA SUPER MINI MOLD)
 30 (SOT 323 STYLE)	 33 (SOT 23 STYLE)
 39 (SOT 143 STYLE)	 39R (SOT 143R STYLE)

ELECTRICAL CHARACTERISTICS (TA = 25°C)

PART NUMBER ¹ EIAJ ² REGISTERED NUMBER PACKAGE OUTLINE			NE68718 2SC5185 18			NE68719 2SC5186 19			NE68730 2SC5184 30			NE68733 2SC5182 33			NE68739/39R 2SC5183/83R 39/39R		
SYMBOLS	PARAMETERS AND CONDITIONS	UNITS	MIN	TYP	MAX	MIN	TYP	MAX	MIN	TYP	MAX	MIN	TYP	MAX	MIN	TYP	MAX
ft	Gain Bandwidth Product at VCE = 2 V, IC = 20 mA, f = 2.0 GHz	GHz	10	13		9	11		9	11		9	12		7.5	10	
ft	Gain Bandwidth Product at VCE = 1 V, IC = 10 mA, f = 2.0 GHz	GHz	8	11		7	9		7	9		7	10		7	8.5	
NFMIN	Minimum Noise Figure at VCE = 2 V, IC = 3 mA, f = 2.0 GHz	dB		1.3	2.0		1.3	2.0		1.3	2.0		1.3	2.0		1.3	2.0
NFMIN	Minimum Noise Figure at VCE = 1 V, IC = 3 mA, f = 2.0 GHz	dB		1.3	2.0		1.3	2.0		1.3	2.0		1.3	2.0		1.3	2.0
S21e ²	Insertion Power Gain at VCE = 2 V, IC = 20 mA, f = 2.0 GHz	dB	8	11		8.5	10		7	8.5		7	8.5		7.5	10	
S21e ²	Insertion Power Gain at VCE = 1 V, IC = 10 mA, f = 2.0 GHz	dB	7.5	9		6	7.5		6	7.5		6	7.5		7	8.5	
hFE	Forward Current Gain ³ at VCE = 2 V, IC = 20 mA		70		140	70		140	70		140	70		140	70		140
ICBO	Collector Cutoff Current at VCB = 5 V, IE = 0 mA	nA			100			100			100			100			100
IEBO	Emitter Cutoff Current at VEB = 1 V, IC = 0 mA	nA			100			100			100			100			100
CRE ⁴	Feedback Capacitance at VCB = 2 V, IE = 0 mA, f = 1 MHz	pF		0.3	0.6		0.4	0.8		0.4	0.8		0.4	0.8		0.4	0.8
PT	Total Power Dissipation	mW			90			90			90			90			90
RTH(J-A)	Thermal Resistance (Junction to Ambient)	°C/W			833			1250			833			625			625
RTH(J-C)	Thermal Resistance (Junction to Case)	°C/W															

Notes:

1. Precaution: Devices are ESD sensitive. Use proper handling procedures.
2. Electronic Industrial Association of Japan.
3. Pulsed measurement, PW ≤ 350 μs, duty cycle ≤ 2%.
4. The emitter terminal should be connected to the ground terminal of the 3 terminal capacitance bridge.

California Eastern Laboratories

NE687 SERIES

ABSOLUTE MAXIMUM RATINGS¹ (T_A = 25°C)

SYMBOLS	PARAMETERS	UNITS	RATINGS
V _{CB0}	Collector to Base Voltage	V	5
V _{CE0}	Collector to Emitter Voltage	V	3
V _{EB0}	Emitter to Base Voltage	V	2
I _C	Collector Current	mA	30
T _J	Operating Junction Temperature	°C	150
T _{STG}	Storage Temperature	°C	-65 to +150

Note:

1. Operation in excess of any one of these parameters may result in permanent damage.

NE68718

TYPICAL NOISE PARAMETERS (T_A = 25°C)

FREQ. (MHz)	NF _{OPT} (dB)	G _A (dB)	Γ _{OPT}		R _{n/50}
			MAG	ANG	
V _{CE} = 0.5 V, I _C = 0.5 mA					
500	1.10	13.07	0.72	30	1.00
800	1.31	11.23	0.67	54	0.65
1000	1.41	9.36	0.65	67	0.55
V _{CE} = 1.0 V, I _C = 1.0 mA					
500	0.93	16.53	0.63	27	0.56
800	1.08	13.44	0.59	47	0.39
1000	1.20	12.21	0.55	62	0.36
1500	1.48	8.53	0.46	83	0.34
2000	1.72	6.50	0.37	107	0.28
V _{CE} = 1.0 V, I _C = 3 mA					
500	1.10	18.68	0.48	23	0.28
800	1.15	15.74	0.40	48	0.25
1000	1.20	13.90	0.36	58	0.24
1500	1.38	10.63	0.28	81	0.21
2000	1.60	8.43	0.21	104	0.20
2500	1.82	7.04	0.14	151	0.18
3000	2.00	5.84	0.16	-167	0.13
V _{CE} = 2 V, I _C = 3 mA					
500	1.10	19.83	0.50	21	0.26
800	1.15	16.61	0.42	39	0.26
1000	1.20	14.85	0.38	48	0.25
1500	1.38	11.83	0.29	74	0.24
2000	1.60	9.49	0.23	91	0.22
2500	1.82	8.16	0.14	135	0.20
3000	2.00	6.93	0.13	177	0.12
V _{CE} = 2 V, I _C = 10 mA					
500	1.60	22.57	0.13	19	0.27
800	1.62	18.75	0.11	48	0.26
1000	1.65	16.91	0.09	67	0.25
1500	1.73	13.52	0.07	100	0.24
2000	1.80	11.17	0.06	143	0.22
2500	2.00	9.48	0.08	-161	0.20
3000	2.19	8.18	0.13	-133	0.16

NE68730

TYPICAL NOISE PARAMETERS (T_A = 25°C)

FREQ. (MHz)	NF _{OPT} (dB)	G _A (dB)	Γ _{OPT}		R _{n/50}
			MAG	ANG	
V _{CE} = 1.0 V, I _C = 3.0 mA					
500	1.10	17.66	0.47	15	0.28
800	1.19	14.48	0.39	33	1.20
1000	1.25	12.93	0.34	45	0.28
1500	1.36	9.61	0.29	57	0.27
2000	1.50	7.52	0.24	73	0.27
V _{CE} = 2.0 V, I _C = 3.0 mA					
500	1.10	18.60	0.40	12	0.30
800	1.19	15.10	0.35	24	0.22
1000	1.25	13.40	0.31	33	0.26
1500	1.36	10.30	0.26	44	0.28
2000	1.50	8.10	0.23	58	0.28
V _{CE} = 2.0 V, I _C = 20.0 mA					
500	2.00	20.30	0.02	-170	0.23
800	2.06	16.70	0.06	171	0.15
1000	2.10	15.00	0.08	172	0.28
1500	2.20	11.90	0.12	178	0.24
2000	2.34	9.80	0.14	-175	0.24
2500	2.46	6.70	0.18	-160	0.23

NE68739

TYPICAL NOISE PARAMETERS (T_A = 25°C)

FREQ. (MHz)	NF _{OPT} (dB)	G _A (dB)	Γ _{OPT}		R _{n/50}
			MAG	ANG	
V _{CE} = 0.5 V, I _C = 0.5 mA					
500	1.23	15.7	0.77	36	0.61
800	1.37	10.9	0.71	46	0.61
1000	1.45	8.7	0.60	64	0.50
V _{CE} = 1.0 V, I _C = 3.0 mA					
500	1.07	18.0	0.48	30	0.31
800	1.13	14.8	0.39	49	0.28
1000	1.18	13.2	0.32	60	0.26
1500	1.30	10.5	0.23	76	0.24
2000	1.50	8.0	0.12	120	0.20
2500	1.66	7.0	0.16	-172	0.15
V _{CE} = 2.0 V, I _C = 3.0 mA					
500	1.07	18.6	0.46	26	0.28
800	1.13	15.5	0.37	38	0.28
1000	1.18	14.0	0.32	46	0.26
1500	1.30	11.2	0.20	66	0.25
2000	1.50	9.3	0.12	113	0.19
2500	1.66	7.8	0.14	177	0.17
3000	1.86	6.6	0.23	-157	0.10
V _{CE} = 2.0 V, I _C = 20.0 mA					
500	1.93	21.2	0.08	-150	0.22
800	1.95	17.6	0.14	-138	0.17
1000	2.00	16.0	0.16	-134	0.17
1500	2.15	12.9	0.21	-127	0.24
2000	2.30	10.6	0.26	-123	0.25
2500	2.40	9.0	0.31	-121	0.25
3000	2.52	7.7	0.46	-114	0.24

TYPICAL PERFORMANCE CURVES (TA = 25°)

NE68718, NE68730
D.C. POWER DERATING CURVE

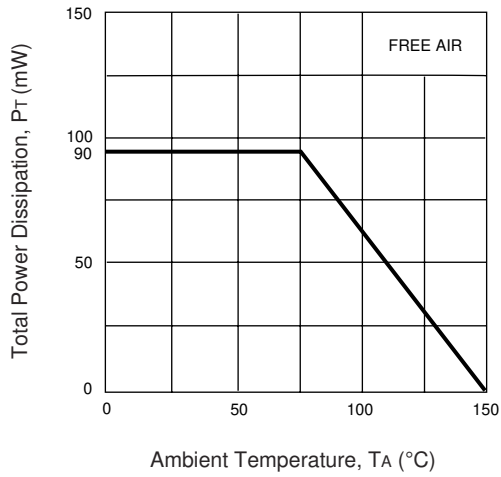

NE68719
D.C. POWER DERATING CURVE

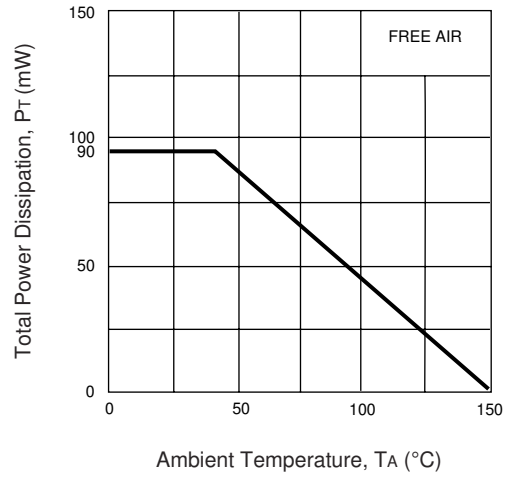

NE68733, NE68739
D.C. POWER DERATING CURVE

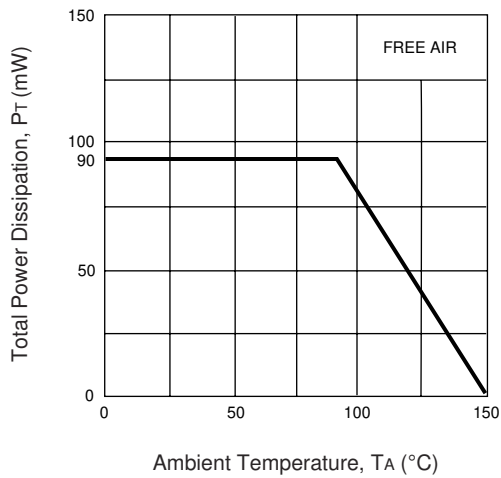

COLLECTOR CURRENT vs. COLLECTOR TO EMITTER VOLTAGE

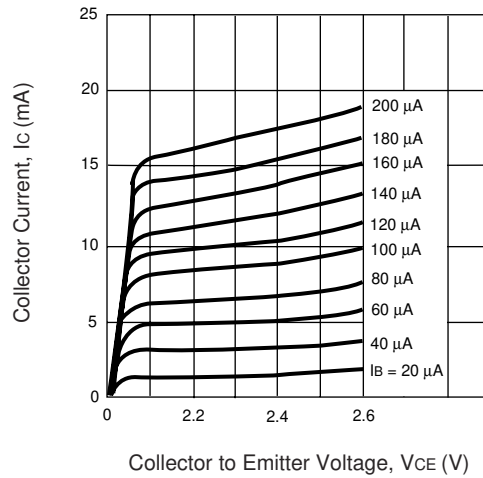

TYPICAL PERFORMANCE CURVES (TA = 25°C)

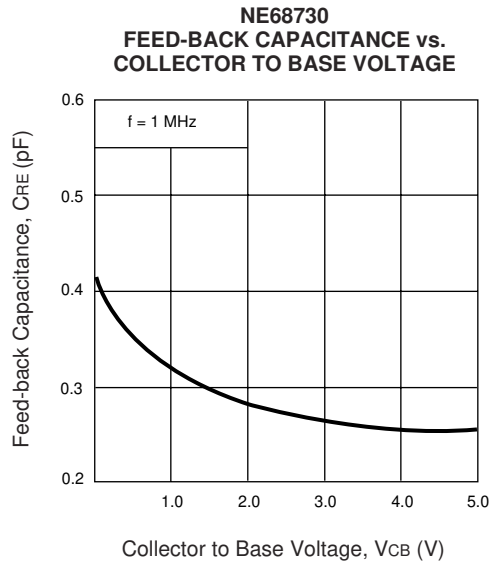
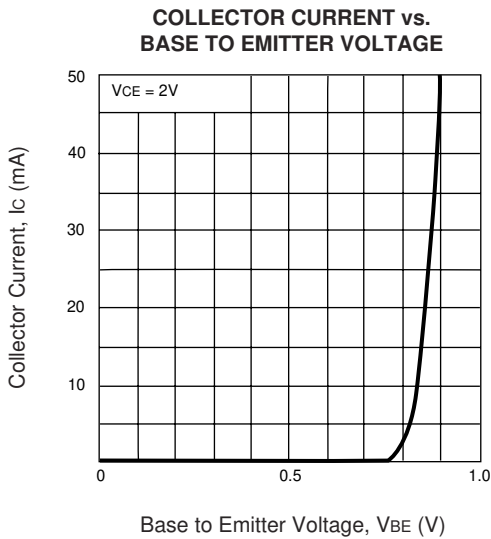
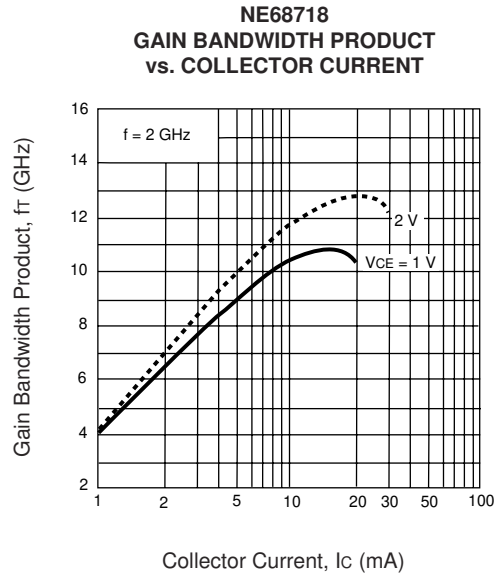
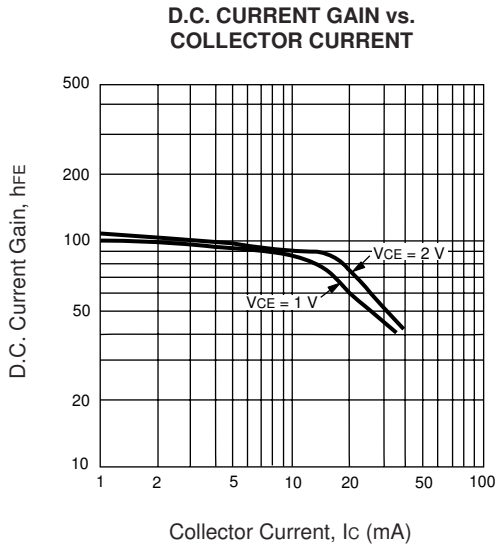
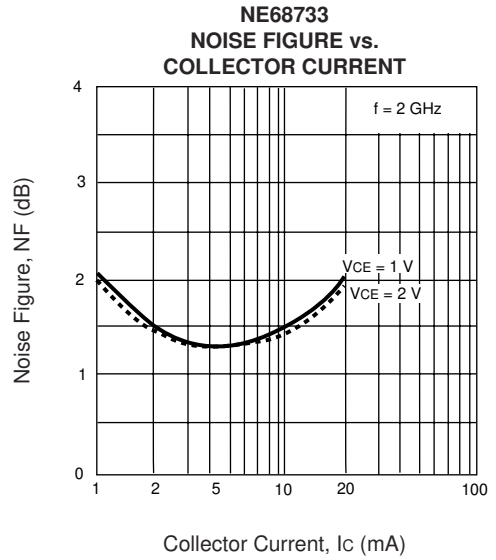
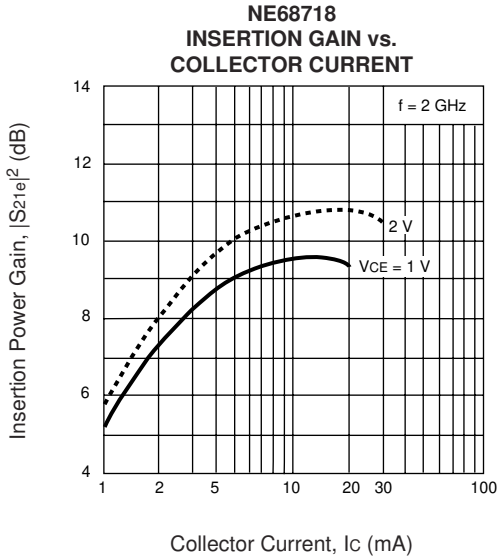

TYPICAL SCATTERING PARAMETERS (TA = 25°C)

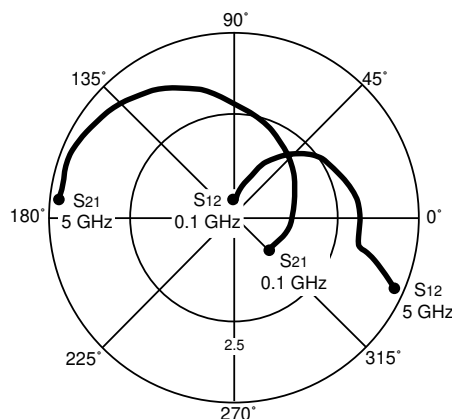
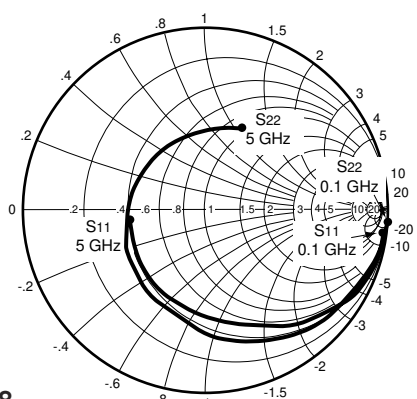

Coordinates in Ohms
Frequency in GHz
(VCE = 1 V, IC = 1 mA)

NE68718

VCE = 1.0 V, IC = 1.0 mA

FREQUENCY GHz	S11		S21		S12		S22		K	MAG ¹ (dB)
	MAG	ANG	MAG	ANG	MAG	ANG	MAG	ANG		
0.1	0.962	-8.100	3.385	168.800	0.023	81.800	0.993	-6.700	0.122	21.678
0.4	0.893	-38.800	3.278	144.800	0.091	62.800	0.944	-25.400	0.160	15.566
0.8	0.755	-73.500	2.809	114.700	0.152	40.300	0.831	-45.900	0.321	12.667
1.0	0.689	-89.000	2.566	101.800	0.170	31.300	0.776	-54.200	0.399	11.788
1.5	0.559	-124.000	2.063	74.800	0.192	13.700	0.666	-71.100	0.593	10.312
2.0	0.481	-154.200	1.704	52.700	0.197	2.300	0.599	-84.300	0.787	9.370
2.5	0.440	178.000	1.461	33.400	0.195	-5.200	0.560	-96.200	0.968	8.746
3.0	0.417	152.500	1.288	16.800	0.195	-9.700	0.531	-107.700	1.131	5.997
4.0	0.434	103.700	1.083	-13.500	0.215	-14.400	0.473	-133.500	1.264	3.931
5.0	0.512	63.400	0.929	-42.700	0.270	-23.500	0.410	-174.700	1.201	2.658

VCE = 1.0 V, IC = 3.0 mA

0.1	0.872	-14.000	8.998	165.400	0.023	80.600	0.971	-11.300	0.117	25.924
0.4	0.710	-60.600	7.542	130.500	0.079	55.100	0.807	-39.500	0.288	19.799
0.8	0.501	-104.700	5.258	99.100	0.114	37.200	0.595	-61.600	0.543	16.639
1.0	0.438	-122.100	4.463	87.700	0.124	32.100	0.527	-68.900	0.653	15.562
1.5	0.354	-159.700	3.211	65.100	0.144	24.100	0.425	-82.000	0.875	13.483
2.0	0.321	170.800	2.502	46.800	0.164	18.400	0.377	-92.400	1.025	10.866
2.5	0.312	145.400	2.064	30.300	0.186	12.900	0.352	-101.800	1.112	8.414
3.0	0.311	123.000	1.777	15.400	0.210	6.800	0.334	-111.500	1.160	6.851
4.0	0.361	83.600	1.438	-12.600	0.263	-7.700	0.280	-136.000	1.163	4.930
5.0	0.461	51.700	1.206	-40.100	0.315	-25.300	0.211	177.500	1.140	3.560

VCE = 1.0 V, IC = 10.0 mA

0.1	0.645	-29.400	21.295	155.400	0.019	74.200	0.892	-21.300	0.247	30.495
0.4	0.392	-95.800	12.537	110.900	0.055	55.600	0.541	-57.100	0.618	23.578
0.8	0.270	-144.400	7.101	85.100	0.085	50.500	0.347	-73.800	0.884	19.219
1.0	0.252	-161.700	5.792	76.200	0.100	48.600	0.303	-79.000	0.948	17.628
1.5	0.234	164.600	3.980	58.000	0.136	42.200	0.249	-89.300	1.037	13.489
2.0	0.234	140.600	3.042	42.500	0.174	34.400	0.226	-98.900	1.069	10.825
2.5	0.235	121.100	2.489	27.900	0.212	25.600	0.215	-107.400	1.079	8.983
3.0	0.242	103.100	2.127	14.200	0.249	16.000	0.207	-117.800	1.080	7.590
4.0	0.300	73.800	1.705	-12.200	0.318	-4.300	0.161	-151.100	1.065	5.736
5.0	0.414	47.400	1.421	-38.700	0.374	-25.800	0.141	133.500	1.054	4.375

VCE = 2.0 V, IC = 3.0 mA

0.1	0.881	-12.200	9.094	166.600	0.017	79.500	0.977	-9.600	0.142	27.283
0.4	0.736	-52.900	7.869	134.300	0.066	58.400	0.844	-34.300	0.280	20.764
0.8	0.527	-92.900	5.706	103.400	0.099	40.800	0.653	-54.800	0.521	17.607
1.0	0.454	-109.000	4.901	91.900	0.109	35.700	0.586	-61.700	0.629	16.529
1.5	0.344	-144.400	3.575	69.100	0.128	27.300	0.485	-74.400	0.847	14.461
2.0	0.294	-174.000	2.789	50.900	0.146	21.700	0.434	-84.700	1.002	12.525
2.5	0.274	159.700	2.308	34.500	0.166	16.500	0.410	-94.000	1.087	9.632
3.0	0.264	136.200	1.980	19.800	0.189	11.100	0.393	-103.600	1.134	7.975
4.0	0.306	94.100	1.605	-7.800	0.241	-2.400	0.343	-126.700	1.130	6.042
5.0	0.407	59.500	1.356	-35.700	0.296	-19.700	0.264	-167.400	1.102	4.663

Note:

1. Gain Calculations:

$$MAG = \frac{|S_{21}|}{|S_{12}|} (K \pm \sqrt{K^2 - 1}). \text{ When } K \leq 1, \text{ MAG is undefined and MSG values are used. } MSG = \frac{|S_{21}|}{|S_{12}|}, K = \frac{1 + |\Delta|^2 - |S_{11}|^2 - |S_{22}|^2}{2 |S_{12} S_{21}|}, \Delta = S_{11} S_{22} - S_{21} S_{12}$$

MAG = Maximum Available Gain

MSG = Maximum Stable Gain

NE687 SERIES

TYPICAL SCATTERING PARAMETERS (T_A = 25°C)

NE68718

VCE = 2.0 V, Ic = 7.0 mA

FREQUENCY GHz	S ₁₁		S ₂₁		S ₁₂		S ₂₂		K	MAG ¹ (dB)
	MAG	ANG	MAG	ANG	MAG	ANG	MAG	ANG		
0.1	0.745	-19.300	17.318	160.600	0.017	74.400	0.942	-14.900	0.242	30.080
0.4	0.501	-72.400	12.131	119.600	0.053	57.300	0.677	-44.600	0.500	23.596
0.8	0.306	-114.500	7.399	91.300	0.080	48.800	0.471	-60.500	0.790	19.661
1.0	0.257	-131.700	6.113	81.600	0.092	46.600	0.419	-65.300	0.877	18.225
1.5	0.202	-168.800	4.245	62.300	0.123	40.700	0.354	-74.800	0.995	15.380
2.0	0.181	160.000	3.252	46.200	0.155	34.000	0.326	-84.000	1.051	11.842
2.5	0.177	134.700	2.655	31.300	0.187	26.200	0.315	-92.700	1.073	9.870
3.0	0.182	113.100	2.269	17.600	0.219	17.800	0.305	-102.300	1.080	8.424
4.0	0.236	78.300	1.820	-8.500	0.284	-0.500	0.257	-127.400	1.065	6.508
5.0	0.356	50.600	1.530	-35.200	0.343	-21.000	0.175	-178.000	1.049	5.142

VCE = 2.0 V, Ic = 20.0 mA

0.1	0.491	-34.600	29.872	150.600	0.014	74.200	0.851	-22.900	0.370	33.291
0.4	0.259	-102.300	15.243	105.900	0.042	63.500	0.479	-52.400	0.781	25.598
0.8	0.174	-151.900	8.321	82.800	0.072	59.100	0.327	-62.200	0.966	20.628
1.0	0.160	-169.400	6.748	74.700	0.087	56.600	0.296	-65.700	1.004	18.526
1.5	0.158	155.900	4.599	57.900	0.125	48.700	0.262	-74.300	1.040	14.437
2.0	0.163	131.600	3.497	43.300	0.163	39.800	0.249	-83.500	1.053	11.911
2.5	0.169	112.200	2.843	29.400	0.199	30.300	0.246	-92.200	1.057	10.084
3.0	0.173	95.000	2.416	16.300	0.235	20.300	0.242	-102.400	1.058	8.648
4.0	0.228	69.700	1.929	-9.100	0.303	0.001	0.196	-130.200	1.044	6.752
5.0	0.349	46.900	1.611	-35.100	0.361	-21.600	0.127	164.300	1.035	5.346

Note:

1. Gain Calculations:

$$\text{MAG} = \frac{|S_{21}|}{|S_{12}|} (K \pm \sqrt{K^2 - 1}). \text{ When } K \leq 1, \text{ MAG is undefined and MSG values are used. } \text{MSG} = \frac{|S_{21}|}{|S_{12}|}, K = \frac{1 + |\Delta|^2 - |S_{11}|^2 - |S_{22}|^2}{2 |S_{12} S_{21}|}, \Delta = S_{11} S_{22} - S_{21} S_{12}$$

MAG = Maximum Available Gain

MSG = Maximum Stable Gain

TYPICAL SCATTERING PARAMETERS (TA = 25°C)

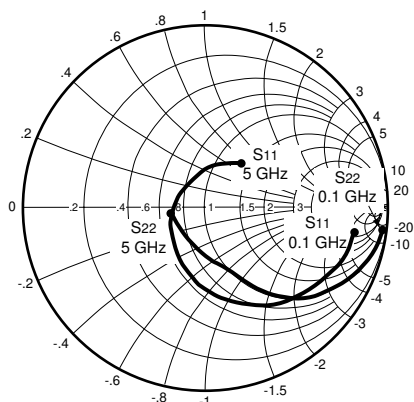

Coordinates in Ohms
Frequency in GHz
(VCE = 2 V, IC = 5 mA)

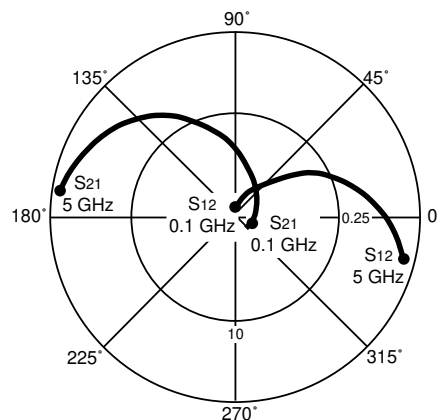

NE68719

VCE = 1.0 V, IC = 1.0 mA

FREQUENCY	S11		S21		S12		S22		K	MAG ¹
GHz	MAG	ANG	MAG	ANG	MAG	ANG	MAG	ANG		(dB)
0.1	0.945	-9.900	3.475	168.900	0.027	82.500	0.992	-6.900	0.085	21.096
0.4	0.890	-39.700	3.213	143.800	0.097	62.200	0.936	-25.900	0.174	15.201
0.8	0.748	-74.800	2.705	114.000	0.158	40.600	0.817	-45.200	0.336	12.335
1.0	0.682	-89.600	2.449	101.900	0.176	32.300	0.764	-52.500	0.417	11.435
1.5	0.559	-122.400	1.957	76.300	0.197	17.100	0.658	-65.800	0.624	9.971
2.0	0.488	-150.400	1.629	55.800	0.203	7.800	0.589	-75.500	0.822	9.044
2.5	0.441	-176.700	1.427	38.000	0.206	2.300	0.540	-84.200	0.994	8.406
3.0	0.411	-158.700	1.288	22.100	0.210	-0.600	0.494	-94.200	1.148	5.541
4.0	0.408	110.100	1.113	-7.200	0.247	-4.600	0.409	-123.800	1.233	3.628
5.0	0.457	64.500	0.959	-35.600	0.319	-14.700	0.393	-171.200	1.147	2.454

VCE = 1.0 V, IC = 3.0 mA

0.1	0.854	-15.800	9.251	165.000	0.026	79.100	0.969	-11.700	0.132	25.512
0.4	0.694	-60.500	7.411	129.600	0.082	55.800	0.792	-40.000	0.312	19.561
0.8	0.485	-102.100	5.078	99.200	0.117	40.200	0.582	-60.000	0.575	16.375
1.0	0.425	-118.200	4.308	88.600	0.128	36.100	0.517	-65.700	0.683	15.271
1.5	0.332	-150.100	3.098	67.200	0.152	30.200	0.421	-74.600	0.902	13.092
2.0	0.294	-176.000	2.442	50.200	0.177	25.900	0.368	-80.500	1.034	10.273
2.5	0.277	160.700	2.052	34.700	0.207	21.200	0.331	-86.100	1.093	8.101
3.0	0.266	140.200	1.795	20.500	0.240	15.400	0.295	-94.200	1.123	6.608
4.0	0.304	97.300	1.486	-6.400	0.312	0.800	0.212	-127.000	1.108	4.780
5.0	0.386	55.900	1.263	-33.100	0.379	-17.300	0.215	-172.500	1.074	3.562

VCE = 1.0 V, IC = 10.0 mA

0.1	0.621	-32.800	21.498	153.900	0.022	74.000	0.883	-22.400	0.255	29.900
0.4	0.376	-98.600	11.952	109.600	0.057	56.500	0.514	-57.600	0.651	23.216
0.8	0.257	-144.700	6.684	85.200	0.089	52.900	0.325	-71.000	0.916	18.756
1.0	0.233	-161.000	5.451	76.800	0.105	51.400	0.284	-74.100	0.980	17.153
1.5	0.206	169.800	3.754	59.800	0.146	45.700	0.231	-78.100	1.055	12.670
2.0	0.195	148.100	2.890	45.100	0.187	38.600	0.204	-81.300	1.085	10.111
2.5	0.190	130.800	2.374	31.500	0.230	30.200	0.184	-84.500	1.092	8.288
3.0	0.192	116.700	2.055	18.600	0.272	21.200	0.159	-91.900	1.090	6.956
4.0	0.258	84.100	1.666	-6.900	0.353	1.600	0.087	-145.200	1.069	5.134
5.0	0.369	47.400	1.402	-31.900	0.414	-19.100	0.170	-137.600	1.048	3.958

VCE = 2.0 V, IC = 3.0 mA

0.1	0.875	-14.200	9.368	165.600	0.022	79.800	0.975	-10.200	0.134	26.292
0.4	0.713	-54.800	7.686	132.000	0.070	57.900	0.817	-35.100	0.322	20.406
0.8	0.503	-92.800	5.388	101.900	0.103	42.800	0.615	-53.100	0.587	17.186
1.0	0.429	-107.500	4.581	91.300	0.113	38.800	0.551	-58.300	0.704	16.079
1.5	0.325	-137.400	3.322	70.100	0.136	32.800	0.453	-66.500	0.924	13.879
2.0	0.270	-163.000	2.611	53.200	0.159	28.900	0.402	-72.600	1.063	10.615
2.5	0.241	175.400	2.175	38.300	0.185	24.600	0.368	-78.200	1.140	8.432
3.0	0.226	155.900	1.903	24.700	0.216	19.600	0.337	-85.800	1.160	7.024
4.0	0.247	111.400	1.588	-1.600	0.288	6.100	0.256	-113.400	1.125	5.264
5.0	0.328	65.600	1.369	-28.500	0.359	-11.900	0.245	-168.700	1.062	4.288

See note on previous page.

NE687 SERIES

TYPICAL SCATTERING PARAMETERS (T_A = 25°C)

NE68719

V_{CE} = 2.0 V, I_C = 5.0 mA

FREQUENCY GHz	S ₁₁		S ₂₁		S ₁₂		S ₂₂		K	MAG ¹ (dB)
	MAG	ANG	MAG	ANG	MAG	ANG	MAG	ANG		
0.1	0.795	-18.000	13.956	162.300	0.020	76.300	0.954	-13.300	0.200	28.437
0.4	0.577	-66.300	10.170	123.500	0.062	56.800	0.721	-41.500	0.440	22.149
0.8	0.364	-106.100	6.431	94.800	0.090	46.900	0.508	-57.100	0.740	18.540
1.0	0.303	-120.700	5.350	85.100	0.102	44.900	0.452	-61.000	0.844	17.198
1.5	0.224	-151.800	3.763	65.800	0.132	40.100	0.377	-66.900	1.000	14.550
2.0	0.187	-178.500	2.912	49.900	0.163	35.300	0.340	-71.600	1.079	10.809
2.5	0.171	159.500	2.403	35.700	0.197	29.100	0.316	-76.100	1.108	8.858
3.0	0.165	139.500	2.086	22.700	0.233	22.100	0.291	-83.000	1.112	7.483
4.0	0.212	96.600	1.712	-2.900	0.309	5.600	0.207	-110.900	1.087	5.641
5.0	0.319	53.600	1.460	-29.000	0.378	-14.000	0.192	-174.900	1.047	4.538

V_{CE} = 2.0 V, I_C = 20.0 mA

0.1	0.469	-38.900	29.942	148.800	0.016	71.900	0.835	-24.600	0.390	32.722
0.4	0.247	-106.600	14.412	104.600	0.045	64.000	0.448	-53.100	0.809	25.055
0.8	0.166	-153.400	7.775	82.800	0.077	61.100	0.303	-59.500	0.987	20.042
1.0	0.148	-169.000	6.300	75.200	0.094	58.900	0.276	-60.900	1.018	17.433
1.5	0.129	161.600	4.295	59.400	0.135	51.600	0.246	-63.500	1.056	13.584
2.0	0.122	139.700	3.279	45.600	0.176	43.500	0.232	-66.900	1.069	11.099
2.5	0.115	124.900	2.678	32.900	0.217	34.400	0.223	-70.400	1.072	9.271
3.0	0.116	114.300	2.304	20.600	0.258	25.300	0.205	-77.100	1.069	7.908
4.0	0.187	85.100	1.857	-3.600	0.337	5.700	0.120	-110.500	1.053	6.005
5.0	0.307	47.800	1.572	-28.300	0.403	-15.200	0.137	160.100	1.032	4.822

Note:

1. Gain Calculations:

$$\text{MAG} = \frac{|S_{21}|}{|S_{12}|} (K \pm \sqrt{K^2 - 1}). \text{ When } K \leq 1, \text{ MAG is undefined and MSG values are used. } \text{MSG} = \frac{|S_{21}|}{|S_{12}|}, K = \frac{1 + |\Delta|^2 - |S_{11}|^2 - |S_{22}|^2}{2 |S_{12} S_{21}|}, \Delta = S_{11} S_{22} - S_{21} S_{12}$$

MAG = Maximum Available Gain

MSG = Maximum Stable Gain

TYPICAL SCATTERING PARAMETERS (TA = 25°C)

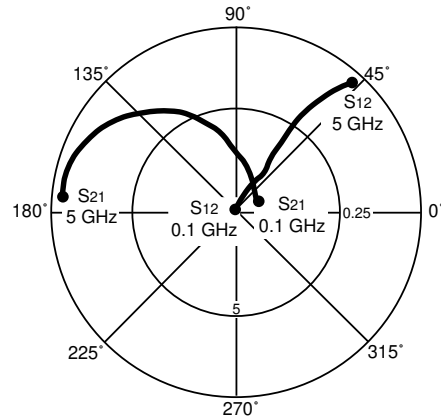
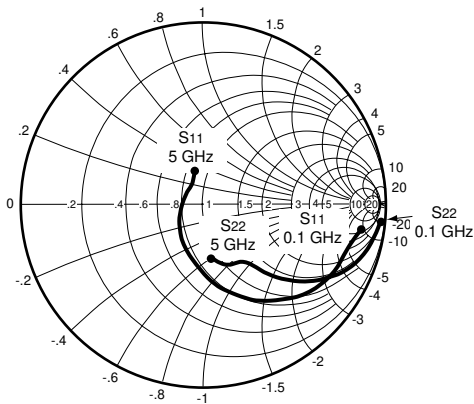

Coordinates in Ohms
Frequency in GHz
(VCE = 2 V, IC = 3 mA)

NE68730

VCE = 1.0 V, IC = 1.0 mA

FREQUENCY GHz	S11		S21		S12		S22		K	MAG ¹ (dB)
	MAG	ANG	MAG	ANG	MAG	ANG	MAG	ANG		
0.1	0.942	-7.800	3.487	169.100	0.028	84.900	0.991	-5.800	0.098	20.953
0.4	0.870	-35.400	3.178	146.800	0.103	67.200	0.924	-21.300	0.208	14.893
0.8	0.714	-65.000	2.676	120.900	0.167	51.600	0.791	-36.200	0.392	12.048
1.0	0.639	-77.100	2.433	110.800	0.185	46.500	0.732	-41.300	0.484	11.190
1.5	0.493	-103.600	1.944	90.400	0.207	39.200	0.621	-50.400	0.707	9.727
2.0	0.400	-125.900	1.621	75.500	0.216	38.200	0.557	-56.400	0.905	8.753
2.5	0.334	-147.500	1.412	63.200	0.224	41.400	0.520	-61.600	1.063	6.464
3.0	0.298	-169.000	1.269	53.200	0.242	46.600	0.495	-66.800	1.139	4.930
4.0	0.268	145.900	1.085	38.200	0.325	53.700	0.455	-77.900	1.108	3.231
5.0	0.328	110.600	0.990	26.400	0.449	51.000	0.389	-96.200	1.016	2.652

VCE = 1.0 V, IC = 3.0 mA

0.1	0.853	-14.800	9.270	164.300	0.026	81.700	0.963	-11.100	0.134	25.521
0.4	0.653	-55.800	7.088	131.200	0.087	61.800	0.758	-35.400	0.385	19.110
0.8	0.430	-89.900	4.754	105.400	0.126	54.000	0.541	-49.200	0.670	15.767
1.0	0.361	-102.200	4.019	97.100	0.141	53.300	0.477	-52.300	0.778	14.549
1.5	0.260	-128.600	2.893	81.600	0.177	54.200	0.388	-56.600	0.951	12.134
2.0	0.207	-150.800	2.283	70.200	0.215	55.000	0.348	-59.300	1.037	9.084
2.5	0.173	-173.200	1.916	60.600	0.255	55.100	0.330	-62.000	1.073	7.114
3.0	0.159	165.900	1.681	52.200	0.298	54.300	0.322	-65.400	1.072	5.880
4.0	0.166	126.100	1.394	38.600	0.387	50.200	0.302	-74.700	1.049	4.212
5.0	0.239	103.800	1.242	26.600	0.476	43.700	0.235	-92.200	1.020	3.302

VCE = 1.0 V, IC = 10.0 mA

0.1	0.590	-30.900	20.999	151.700	0.022	75.800	0.864	-21.900	0.319	29.798
0.4	0.314	-84.600	10.808	111.200	0.064	66.400	0.479	-48.700	0.749	22.276
0.8	0.184	-120.500	5.986	92.200	0.107	68.000	0.312	-53.100	0.950	17.478
1.0	0.155	-133.700	4.891	86.500	0.129	68.100	0.279	-53.400	0.988	15.788
1.5	0.119	-163.200	3.377	75.100	0.184	66.800	0.239	-53.900	1.030	11.572
2.0	0.100	-170.800	2.615	66.300	0.239	63.900	0.225	-55.300	1.043	9.127
2.5	0.098	146.300	2.171	58.300	0.292	60.600	0.223	-57.600	1.040	7.483
3.0	0.099	129.000	1.884	50.900	0.342	56.800	0.224	-61.100	1.035	6.265
4.0	0.121	99.700	1.545	38.800	0.435	48.800	0.211	-72.200	1.024	4.560
5.0	0.193	95.100	1.366	27.400	0.516	40.200	0.140	-95.100	1.012	3.565

Note:

1. Gain Calculations:

$$MAG = \frac{|S_{21}|}{|S_{12}|} (K \pm \sqrt{K^2 - 1})$$

When $K \leq 1$, MAG is undefined and MSG values are used. $MSG = \frac{|S_{21}|}{|S_{12}|}$, $K = \frac{1 + |\Delta|^2 - |S_{11}|^2 - |S_{22}|^2}{2 |S_{12} S_{21}|}$, $\Delta = S_{11} S_{22} - S_{21} S_{12}$

MAG = Maximum Available Gain

MSG = Maximum Stable Gain

NE687 SERIES

TYPICAL SCATTERING PARAMETERS (T_A = 25°C)

NE68730

V_{CE} = 2.0 V, I_C = 3.0 mA

FREQUENCY GHz	S ₁₁		S ₂₁		S ₁₂		S ₂₂		K	MAG ¹ (dB)
	MAG	ANG	MAG	ANG	MAG	ANG	MAG	ANG		
0.1	0.850	-12.800	9.307	165.200	0.023	81.500	0.970	-9.600	0.158	26.071
0.4	0.678	-49.700	7.314	133.800	0.076	64.100	0.792	-30.800	0.381	19.833
0.8	0.450	-80.500	5.036	108.200	0.114	56.500	0.587	-43.100	0.659	16.452
1.0	0.375	-91.900	4.279	99.900	0.128	55.900	0.526	-45.800	0.763	15.241
1.5	0.256	-114.600	3.094	84.300	0.162	56.700	0.439	-49.300	0.939	12.810
2.0	0.187	-135.300	2.436	73.000	0.197	57.600	0.402	-51.700	1.027	9.908
2.5	0.141	-156.700	2.040	63.500	0.236	58.000	0.385	-54.100	1.060	7.874
3.0	0.115	179.500	1.782	55.100	0.276	57.500	0.379	-57.300	1.062	6.578
4.0	0.110	127.300	1.466	41.900	0.362	54.300	0.365	-65.400	1.039	4.866
5.0	0.184	103.000	1.305	30.400	0.453	48.700	0.305	-78.400	1.004	4.201

V_{CE} = 2.0 V, I_C = 5.0 mA

0.1	0.781	-17.800	13.806	161.000	0.021	80.300	0.945	-12.700	0.194	28.178
0.4	0.531	-58.400	9.434	124.700	0.067	64.700	0.683	-36.000	0.533	21.486
0.8	0.313	-86.300	5.827	101.200	0.103	62.400	0.482	-44.100	0.816	17.526
1.0	0.250	-96.500	4.846	94.100	0.120	62.900	0.433	-45.200	0.894	16.062
1.5	0.160	-117.000	3.408	80.700	0.163	63.600	0.371	-46.600	0.998	13.203
2.0	0.104	-136.200	2.651	70.800	0.208	62.900	0.348	-48.200	1.037	9.874
2.5	0.067	-163.800	2.205	62.300	0.253	61.400	0.340	-50.400	1.047	8.077
3.0	0.053	164.400	1.913	54.600	0.298	59.300	0.339	-53.700	1.041	6.833
4.0	0.069	98.700	1.562	42.300	0.386	53.800	0.328	-62.200	1.027	5.072
5.0	0.143	93.700	1.390	31.200	0.474	47.100	0.265	-75.500	1.002	4.419

V_{CE} = 2.0 V, I_C = 20.0 mA

0.1	0.447	-35.800	28.663	146.000	0.017	76.400	0.808	-24.200	0.451	32.269
0.4	0.200	-84.600	12.701	106.600	0.052	72.800	0.422	-43.500	0.876	23.878
0.8	0.103	-117.300	6.817	90.300	0.096	74.000	0.301	-42.600	0.989	18.513
1.0	0.081	-131.600	5.544	85.300	0.117	73.500	0.280	-42.000	1.010	16.144
1.5	0.054	-168.200	3.795	75.300	0.171	70.900	0.258	-42.600	1.028	12.443
2.0	0.046	154.600	2.921	67.300	0.224	67.400	0.253	-44.500	1.030	10.086
2.5	0.049	118.800	2.407	59.900	0.274	63.700	0.256	-47.300	1.029	8.397
3.0	0.057	99.400	2.076	53.200	0.322	59.900	0.261	-51.500	1.023	7.169
4.0	0.086	75.300	1.681	41.800	0.410	52.100	0.255	-61.800	1.014	5.396
5.0	0.140	86.000	1.478	31.200	0.490	44.000	0.187	-77.200	1.005	4.368

Note:

1. Gain Calculations:

$$\text{MAG} = \frac{|S_{21}|}{|S_{12}|} (K \pm \sqrt{K^2 - 1}). \text{ When } K \leq 1, \text{ MAG is undefined and MSG values are used. } \text{MSG} = \frac{|S_{21}|}{|S_{12}|}, K = \frac{1 + |\Delta|^2 - |S_{11}|^2 - |S_{22}|^2}{2 |S_{12} S_{21}|}, \Delta = S_{11} S_{22} - S_{21} S_{12}$$

MAG = Maximum Available Gain

MSG = Maximum Stable Gain

TYPICAL SCATTERING PARAMETERS (T_A = 25°C)

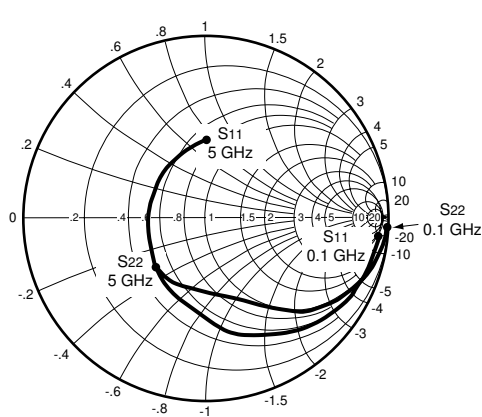

Coordinates in Ohms
Frequency in GHz
(V_{CE} = 1 V, I_c = 1 mA)

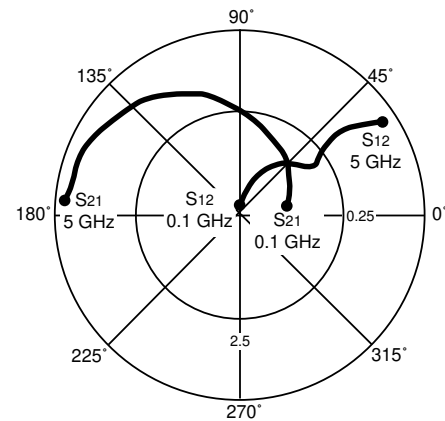

NE68733

V_{CE} = 1.0 V, I_c = 1.0 mA

FREQUENCY	S ₁₁		S ₂₁		S ₁₂		S ₂₂		K	MAG ¹
GHz	MAG	ANG	MAG	ANG	MAG	ANG	MAG	ANG		(dB)
0.1	0.953	-8.300	3.433	170.300	0.031	83.500	0.990	-6.200	0.090	20.443
0.4	0.864	-36.800	3.200	144.900	0.111	66.000	0.921	-23.100	0.221	14.598
0.8	0.688	-68.700	2.683	117.400	0.180	48.900	0.778	-39.800	0.412	11.733
1.0	0.608	-82.600	2.432	106.200	0.200	42.900	0.713	-45.900	0.504	10.849
1.5	0.451	-114.800	1.958	83.500	0.223	34.100	0.583	-57.200	0.732	9.435
2.0	0.359	-145.300	1.631	66.000	0.232	31.500	0.501	-65.800	0.939	8.470
2.5	0.323	-175.700	1.415	51.400	0.242	33.100	0.451	-74.500	1.081	5.930
3.0	0.320	158.100	1.261	40.000	0.263	36.500	0.421	-84.700	1.145	4.499
4.0	0.365	117.200	1.059	21.900	0.351	39.100	0.399	-107.700	1.076	3.119
5.0	0.433	87.400	0.935	7.700	0.470	32.500	0.383	-134.500	1.001	2.817

V_{CE} = 1.0 V, I_c = 3.0 mA

0.1	0.856	-15.400	8.971	165.000	0.029	80.500	0.964	-11.600	0.130	24.904
0.4	0.631	-56.900	6.949	128.500	0.092	60.700	0.751	-37.200	0.416	18.781
0.8	0.389	-93.700	4.599	101.200	0.135	52.500	0.525	-52.300	0.704	15.323
1.0	0.318	-108.300	3.874	92.100	0.152	51.400	0.458	-56.200	0.808	14.063
1.5	0.216	-145.300	2.790	74.600	0.193	50.400	0.358	-62.900	0.972	11.600
2.0	0.184	179.400	2.201	61.200	0.237	49.100	0.304	-69.100	1.045	8.375
2.5	0.199	149.200	1.849	49.400	0.282	46.900	0.271	-77.400	1.065	6.610
3.0	0.220	127.900	1.617	39.800	0.328	43.800	0.252	-88.300	1.065	5.366
4.0	0.285	99.500	1.336	22.800	0.420	35.600	0.242	-114.500	1.032	3.937
5.0	0.360	80.300	1.167	8.000	0.505	25.700	0.231	-144.300	1.005	3.210

V_{CE} = 1.0 V, I_c = 10.0 mA

0.1	0.587	-32.000	19.990	152.200	0.025	75.900	0.862	-22.700	0.306	29.029
0.4	0.295	-88.800	10.311	108.800	0.068	65.200	0.471	-50.700	0.762	21.808
0.8	0.163	-132.400	5.665	88.600	0.115	65.600	0.302	-57.000	0.957	16.925
1.0	0.140	-152.000	4.610	82.100	0.139	64.900	0.266	-58.500	0.994	15.207
1.5	0.133	167.700	3.194	68.900	0.199	61.600	0.215	-63.300	1.029	11.009
2.0	0.151	139.000	2.478	58.200	0.257	56.900	0.185	-70.200	1.040	8.616
2.5	0.183	121.800	2.060	48.100	0.313	51.600	0.166	-80.800	1.035	7.030
3.0	0.210	108.600	1.786	39.700	0.364	46.100	0.156	-95.500	1.033	5.802
4.0	0.263	90.500	1.466	24.000	0.457	34.700	0.163	-129.300	1.017	4.267
5.0	0.330	75.600	1.279	9.700	0.531	23.300	0.169	-164.800	1.007	3.319

Note:

1. Gain Calculations:

$$MAG = \frac{|S_{21}|}{|S_{12}|} (K \pm \sqrt{K^2 - 1}). \text{ When } K \leq 1, \text{ MAG is undefined and MSG values are used. } MSG = \frac{|S_{21}|}{|S_{12}|}, K = \frac{1 + |\Delta|^2 - |S_{11}|^2 - |S_{22}|^2}{2 |S_{12} S_{21}|}, \Delta = S_{11} S_{22} - S_{21} S_{12}$$

MAG = Maximum Available Gain

MSG = Maximum Stable Gain

NE687 SERIES

TYPICAL SCATTERING PARAMETERS (T_A = 25°C)

NE68733

VCE = 2.0 V, Ic = 3.0 mA

FREQUENCY GHz	S ₁₁		S ₂₁		S ₁₂		S ₂₂		K	MAG ¹ (dB)
	MAG	ANG	MAG	ANG	MAG	ANG	MAG	ANG		
0.1	0.860	-13.200	8.984	165.800	0.024	83.200	0.970	-9.900	0.113	25.733
0.4	0.653	-51.000	7.149	131.000	0.081	63.300	0.781	-32.600	0.413	19.458
0.8	0.403	-82.900	4.837	103.900	0.123	55.400	0.570	-45.700	0.702	15.947
1.0	0.324	-95.500	4.091	94.600	0.139	54.300	0.507	-49.000	0.804	14.688
1.5	0.198	-127.200	2.967	77.100	0.179	53.400	0.409	-54.500	0.964	12.195
2.0	0.141	-164.900	2.341	63.700	0.221	52.200	0.358	-59.700	1.037	9.073
2.5	0.139	156.600	1.971	52.100	0.266	50.200	0.325	-66.500	1.054	7.271
3.0	0.164	130.300	1.715	42.300	0.311	47.300	0.305	-75.900	1.053	6.005
4.0	0.230	98.200	1.414	25.400	0.405	39.400	0.286	-99.000	1.018	4.597
5.0	0.311	79.300	1.236	10.300	0.495	29.800	0.264	-125.800	0.988	3.974

VCE = 2.0 V, Ic = 7.0 mA

0.1	0.704	-21.900	16.558	158.400	0.023	77.300	0.922	-16.100	0.248	28.573
0.4	0.410	-66.900	10.214	116.700	0.066	65.000	0.600	-41.100	0.649	21.897
0.8	0.209	-97.700	5.923	94.000	0.107	63.900	0.409	-47.800	0.898	17.432
1.0	0.157	-110.500	4.860	86.800	0.128	63.700	0.365	-49.200	0.954	15.794
1.5	0.092	-152.600	3.391	72.900	0.180	61.700	0.305	-52.500	1.016	11.986
2.0	0.086	157.500	2.635	61.900	0.233	58.100	0.271	-57.400	1.034	9.404
2.5	0.113	127.700	2.193	51.700	0.284	53.800	0.248	-64.800	1.035	7.738
3.0	0.143	110.900	1.896	43.100	0.333	49.000	0.233	-75.300	1.031	6.477
4.0	0.203	89.100	1.551	27.500	0.425	39.000	0.220	-101.500	1.013	4.921
5.0	0.270	76.200	1.353	13.100	0.506	28.400	0.202	-130.800	0.998	4.271

VCE = 2.0 V, Ic = 20.0 mA

0.1	0.437	-34.500	26.620	145.800	0.018	76.800	0.809	-24.400	0.461	31.699
0.4	0.179	-90.400	11.869	104.400	0.056	72.600	0.424	-43.100	0.880	23.262
0.8	0.082	-134.900	6.340	86.700	0.102	71.800	0.306	-43.200	0.996	17.935
1.0	0.067	-160.200	5.143	80.900	0.126	70.500	0.282	-43.800	1.012	15.430
1.5	0.077	149.800	3.531	69.100	0.184	66.200	0.248	-47.500	1.027	11.828
2.0	0.106	123.200	2.732	59.200	0.241	60.900	0.225	-53.300	1.027	9.541
2.5	0.137	109.800	2.254	50.000	0.295	55.400	0.207	-62.300	1.024	7.889
3.0	0.165	99.000	1.946	41.700	0.346	49.700	0.194	-74.900	1.019	6.645
4.0	0.221	83.800	1.594	26.700	0.437	38.400	0.185	-105.800	1.006	5.161
5.0	0.290	73.400	1.379	12.300	0.515	27.000	0.172	-139.300	0.994	4.278

Note:

1. Gain Calculations:

$$\text{MAG} = \frac{|S_{21}|}{|S_{12}|} (K \pm \sqrt{K^2 - 1}). \text{ When } K \leq 1, \text{ MAG is undefined and MSG values are used. } \text{MSG} = \frac{|S_{21}|}{|S_{12}|}, K = \frac{1 + |\Delta|^2 - |S_{11}|^2 - |S_{22}|^2}{2 |S_{12} S_{21}|}, \Delta = S_{11} S_{22} - S_{21} S_{12}$$

MAG = Maximum Available Gain

MSG = Maximum Stable Gain

TYPICAL SCATTERING PARAMETERS (TA = 25°C)

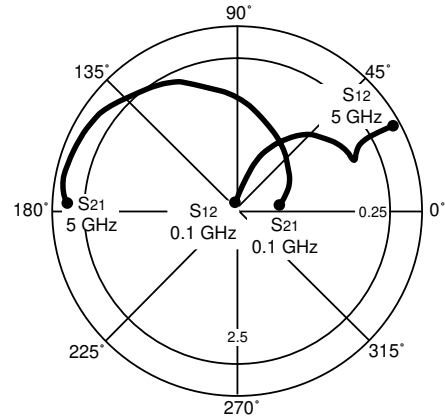
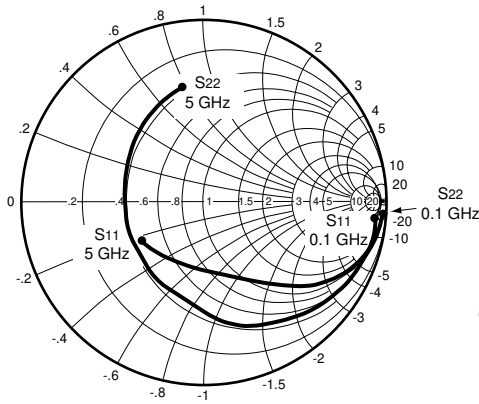

Coordinates in Ohms
Frequency in GHz
(VCE = 1 V, IC = 1 mA)

NE68739

VCE = 1.0 V, IC = 1.0 mA

FREQUENCY GHz	S11		S21		S12		S22		K	MAG ¹ (dB)
	MAG	ANG	MAG	ANG	MAG	ANG	MAG	ANG		
0.1	0.960	-7.500	3.509	172.000	0.024	85.500	0.993	-4.600	0.055	21.650
0.4	0.888	-34.300	3.358	149.700	0.091	68.900	0.941	-17.900	0.181	15.670
0.8	0.734	-67.000	2.974	123.500	0.157	51.100	0.815	-32.000	0.362	12.774
1.0	0.651	-82.900	2.738	112.400	0.178	44.300	0.751	-37.600	0.440	11.870
1.5	0.496	-122.300	2.250	88.500	0.205	31.600	0.602	-49.100	0.642	10.404
2.0	0.436	-159.300	1.842	69.200	0.210	24.400	0.500	-58.700	0.834	9.431
2.5	0.441	169.800	1.566	53.700	0.207	22.000	0.428	-69.200	1.006	8.323
3.0	0.473	147.900	1.339	40.900	0.208	23.300	0.384	-81.700	1.146	5.769
4.0	0.565	119.100	1.047	20.800	0.233	28.500	0.358	-113.400	1.192	3.876
5.0	0.651	99.800	0.852	5.200	0.287	28.500	0.399	-147.500	1.074	3.064

VCE = 1.0 V, IC = 3.0 mA

0.1	0.869	-14.000	9.245	166.800	0.023	81.300	0.971	-9.100	0.122	26.042
0.4	0.690	-53.600	7.614	134.500	0.078	62.400	0.800	-31.100	0.345	19.895
0.8	0.453	-94.600	5.373	106.500	0.116	50.400	0.572	-46.200	0.620	16.658
1.0	0.376	-113.100	4.571	96.900	0.129	47.900	0.493	-50.700	0.730	15.494
1.5	0.295	-157.100	3.303	78.500	0.158	45.000	0.359	-59.700	0.923	13.203
2.0	0.312	168.300	2.556	64.100	0.185	43.300	0.277	-70.300	1.032	10.301
2.5	0.359	145.700	2.105	52.000	0.213	41.400	0.223	-85.000	1.080	8.224
3.0	0.409	130.200	1.785	41.700	0.240	39.200	0.193	-104.300	1.105	6.745
4.0	0.510	109.500	1.385	24.100	0.294	33.400	0.202	-147.000	1.084	4.963
5.0	0.599	94.300	1.134	8.900	0.341	26.000	0.276	-178.000	1.038	4.019

VCE = 1.0 V, IC = 10.0 mA

0.1	0.629	-29.300	21.353	155.300	0.021	76.600	0.887	-19.700	0.262	30.072
0.4	0.370	-90.900	12.179	114.000	0.058	61.700	0.521	-50.300	0.658	23.222
0.8	0.247	-141.800	6.904	92.100	0.092	60.500	0.313	-61.900	0.907	18.753
1.0	0.237	-162.500	5.624	85.300	0.109	60.200	0.261	-66.100	0.964	17.126
1.5	0.268	163.600	3.862	71.900	0.151	57.800	0.182	-80.300	1.027	13.064
2.0	0.323	143.700	2.930	60.700	0.191	54.000	0.143	-103.800	1.052	10.469
2.5	0.380	130.100	2.384	50.800	0.229	49.500	0.137	-132.500	1.053	8.763
3.0	0.428	120.400	2.000	42.200	0.262	45.000	0.158	-157.100	1.060	7.334
4.0	0.526	105.100	1.537	27.100	0.320	35.700	0.231	173.700	1.040	5.586
5.0	0.609	92.600	1.256	13.600	0.362	26.600	0.314	157.000	1.018	4.590

Note:

1. Gain Calculations:

$$MAG = \frac{|S_{21}|}{|S_{12}|} (K \pm \sqrt{K^2 - 1})$$

When $K \leq 1$, MAG is undefined and MSG values are used. $MSG = \frac{|S_{21}|}{|S_{12}|}$, $K = \frac{1 + |\Delta|^2 - |S_{11}|^2 - |S_{22}|^2}{2 |S_{12} S_{21}|}$, $\Delta = S_{11} S_{22} - S_{21} S_{12}$

MAG = Maximum Available Gain

MSG = Maximum Stable Gain

NE687 SERIES

TYPICAL SCATTERING PARAMETERS (T_A = 25°C)

NE68739

VCE = 2.0 V, Ic = 3.0 mA

FREQUENCY GHz	S ₁₁		S ₂₁		S ₁₂		S ₂₂		K	MAG ¹ (dB)
	MAG	ANG	MAG	ANG	MAG	ANG	MAG	ANG		
0.1	0.877	-12.300	9.280	167.700	0.020	85.100	0.976	-8.000	0.076	26.665
0.4	0.717	-48.900	7.832	137.800	0.070	64.500	0.829	-27.700	0.321	20.488
0.8	0.484	-87.400	5.716	110.300	0.107	52.300	0.618	-41.900	0.581	17.277
1.0	0.404	-104.800	4.907	100.700	0.119	49.500	0.542	-46.100	0.685	16.153
1.5	0.299	-147.400	3.585	82.300	0.145	46.300	0.409	-54.200	0.883	13.931
2.0	0.301	176.200	2.784	67.900	0.169	44.900	0.327	-62.800	1.000	12.168
2.5	0.340	151.300	2.293	56.000	0.194	43.500	0.271	-74.100	1.058	9.251
3.0	0.393	134.900	1.939	45.800	0.219	42.000	0.236	-88.400	1.083	7.716
4.0	0.495	113.600	1.500	28.400	0.270	37.300	0.219	-124.100	1.064	5.902
5.0	0.587	98.400	1.227	13.100	0.316	30.900	0.265	-157.500	1.015	5.141

VCE = 2.0 V, Ic = 5.0 mA

0.1	0.804	-15.700	13.813	163.800	0.018	81.700	0.956	-10.300	0.165	28.850
0.4	0.570	-55.800	10.275	128.600	0.058	65.000	0.736	-31.100	0.481	22.484
0.8	0.326	-91.000	6.655	102.800	0.090	59.200	0.522	-40.500	0.774	18.689
1.0	0.252	-108.300	5.559	94.500	0.104	58.500	0.458	-42.800	0.864	17.280
1.5	0.179	-155.100	3.937	78.900	0.138	57.200	0.355	-48.000	0.991	14.553
2.0	0.201	165.000	3.040	66.500	0.173	55.100	0.287	-56.000	1.044	11.167
2.5	0.257	142.400	2.504	55.800	0.208	52.100	0.234	-67.800	1.058	9.338
3.0	0.311	127.700	2.124	46.400	0.242	48.600	0.196	-84.500	1.064	7.885
4.0	0.423	109.600	1.657	29.800	0.304	40.600	0.177	-129.000	1.041	6.124
5.0	0.524	96.000	1.366	14.900	0.356	31.800	0.234	-167.600	1.006	5.353

VCE = 2.0 V, Ic = 20.0 mA

0.1	0.473	-29.900	29.491	150.100	0.014	80.300	0.843	-20.300	0.405	33.236
0.4	0.222	-83.800	14.470	109.000	0.044	70.800	0.475	-40.400	0.838	25.170
0.8	0.113	-135.400	7.915	90.200	0.079	70.200	0.321	-42.300	0.987	20.008
1.0	0.106	-164.400	6.422	84.300	0.097	69.200	0.283	-43.300	1.012	17.550
1.5	0.145	153.400	4.407	72.500	0.140	65.200	0.217	-49.700	1.038	13.780
2.0	0.209	135.300	3.357	62.200	0.182	60.400	0.163	-63.400	1.046	11.350
2.5	0.269	123.800	2.745	53.000	0.222	55.000	0.124	-86.400	1.043	9.652
3.0	0.329	116.000	2.314	44.500	0.258	49.600	0.110	-119.900	1.041	8.283
4.0	0.437	102.500	1.786	29.200	0.321	38.900	0.161	-173.100	1.027	6.450
5.0	0.535	90.900	1.461	15.100	0.368	28.600	0.254	162.100	1.008	5.429

Note:

1. Gain Calculations:

$$\text{MAG} = \frac{|S_{21}|}{|S_{12}|} (K \pm \sqrt{K^2 - 1}). \text{ When } K \leq 1, \text{ MAG is undefined and MSG values are used. } \text{MSG} = \frac{|S_{21}|}{|S_{12}|}, K = \frac{1 + |\Delta|^2 - |S_{11}|^2 - |S_{22}|^2}{2 |S_{12} S_{21}|}, \Delta = S_{11} S_{22} - S_{21} S_{12}$$

MAG = Maximum Available Gain

MSG = Maximum Stable Gain

NE68700 NONLINEAR MODEL

SCHEMATIC

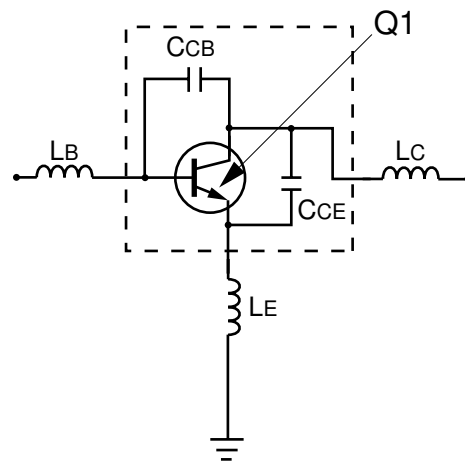
BJT NONLINEAR MODEL PARAMETERS ⁽¹⁾

Parameters	Q1	Parameters	Q1
IS	8.0e-17	MJC	0.53
BF	128	XCJC	0.27
NF	1.0	CJS	0
VAF	17	VJS	0.75
IKF	0.18	MJS	0
ISE	3.3e-15	FC	0.37
NE	1.48	TF	6.0e-12
BR	9.05	XTF	11.9
NR	1.05	VTF	9.55
VAR	4.3	ITF	1.78
IKR	0.009	PTF	69.1
ISC	4.0e-15	TR	1.0e-9
NC	1.5	EG	1.11
RE	0.8	XTB	0
RB	1.11	XTI	3
RBM	2.46	KF	0
IRB	0.017	AF	1
RC	7.5		
CJE	0.415e-12		
VJE	0.68		
MJE	0.53		
CJC	0.102e-12		
VJC	0.29		

(1) Gummel-Poon Model

UNITS

Parameter	Units
time	seconds
capacitance	farads
inductance	henries
resistance	ohms
voltage	volts
current	amps

ADDITIONAL PARAMETERS

Parameters	68700
CcB	0.26e-12
CcE	0.19e-12
Lb	0.49e-9
Lc	0.70e-9
LE	0.26e-9

MODEL RANGE

Frequency: 0.1 to 6.0 GHz

Bias: $V_{CE} = 1\text{ V to }3\text{ V}$, $I_C = 1\text{ mA to }10\text{ mA}$

PdB: 3 V, 10 mA, 2 GHz

NE68718 NONLINEAR MODEL

SCHEMATIC

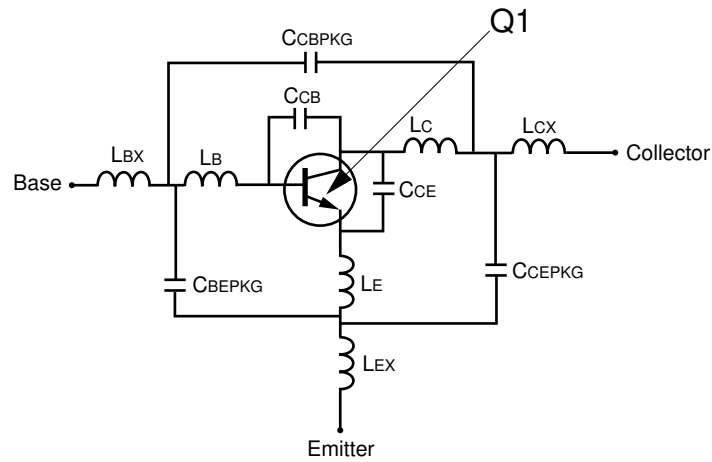

BJT NONLINEAR MODEL PARAMETERS (1)

Parameters	Q1	Parameters	Q1
IS	8.0e-17	MJC	0.53
BF	128	XCJC	0.27
NF	1.0	CJS	0
VAF	17	VJS	0.75
IKF	0.18	MJS	0
ISE	3.3e-15	FC	0.37
NE	1.48	TF	6.0e-12
BR	9.05	XTF	11.9
NR	1.05	VTF	9.55
VAR	4.3	ITF	1.78
IKR	0.009	PTF	69.1
ISC	4.0e-15	TR	1.0e-9
NC	1.5	EG	1.11
RE	0.8	XTB	0
RB	11.1	XTI	3
RBM	2.46	KF	0
IRB	0.017	AF	1
RC	7.5		
CJE	0.415e-12		
VJE	0.68		
MJE	0.53		
CJC	0.102e-12		
VJC	0.29		

(1) Gummel-Poon Model

UNITS

Parameter	Units
time	seconds
capacitance	farads
inductance	henries
resistance	ohms
voltage	volts
current	amps

ADDITIONAL PARAMETERS

Parameters	68718
CBB	0.26e-12
CCE	0.19e-12
LB	1.51e-9
LC	1.18e-9
LE	0.71e-9
CCBPKG	0.063e-12
CCEPKG	0.409e-12
CBEPKG	0.361e-12
LBX	0.18e-9
LCX	0.18e-9
LEX	0.09e-9

MODEL RANGE

Frequency: 0.05 to 5.0 GHz

Bias: VCE = 1 V to 2 V, IC = 1 mA to 10 mA

NE68719 NONLINEAR MODEL

SCHEMATIC

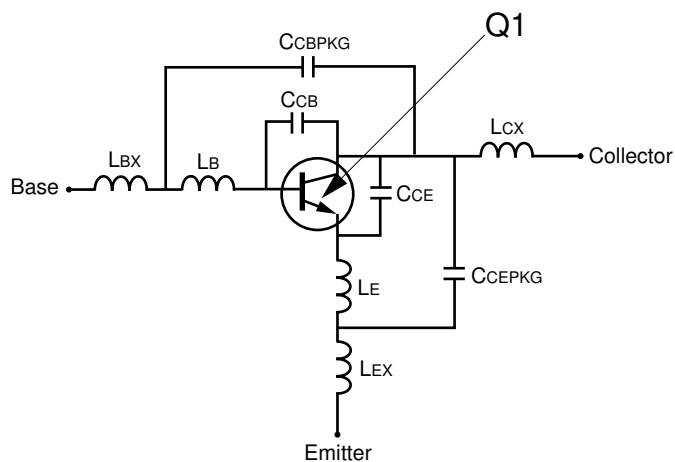
BJT NONLINEAR MODEL PARAMETERS⁽¹⁾

Parameters	Q1	Parameters	Q1
IS	8.0e-17	MJC	0.53
BF	128	XCJC	0.27
NF	1.0	CJS	0
VAF	17	VJS	0.75
IKF	0.18	MJS	0
ISE	3.3e-15	FC	0.37
NE	1.48	TF	6.0e-12
BR	9.05	XTF	11.9
NR	1.05	VTF	9.55
VAR	4.3	ITF	1.78
IKR	0.009	PTF	69.1
ISC	4.0e-15	TR	1.0e-9
NC	1.5	EG	1.11
RE	0.8	XTB	0
RB	11.1	XTI	3
RBM	2.46	KF	0
IRB	0.017	AF	1
RC	7.5		
CJE	0.415e-12		
VJE	0.68		
MJE	0.53		
CJC	0.102e-12		
VJC	0.29		

(1) Gummel-Poon Model

UNITS

Parameter	Units
time	seconds
capacitance	farads
inductance	henries
resistance	ohms
voltage	volts
current	amps

ADDITIONAL PARAMETERS

Parameters	68719
CCB	0.26e-12
CCE	0.19e-12
LB	0.81e-9
LE	0.85e-9
CCBPKG	0.17e-12
CCEPKG	0.21e-12
LBX	0.19e-9
LCX	0.19e-9
LEX	0.19e-9

MODEL TEST CONDITIONS

Frequency: 0.05 to 3.0 GHz

Bias: $V_{CE} = 1\text{ V to }2\text{ V}$, $I_C = 1\text{ mA to }10\text{ mA}$

NE68730 NONLINEAR MODEL

SCHEMATIC

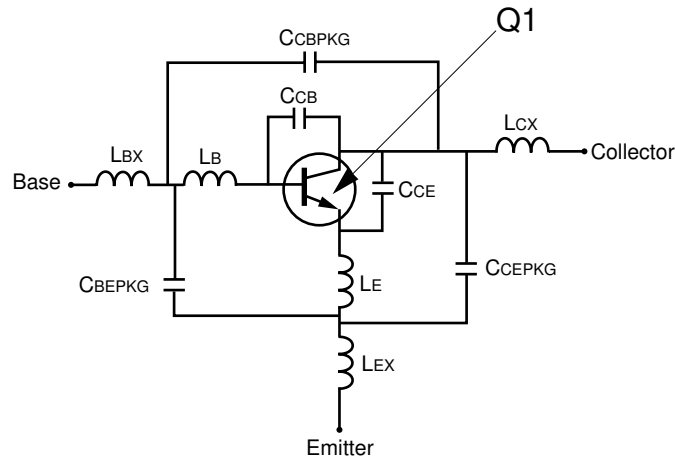

BJT NONLINEAR MODEL PARAMETERS (1)

Parameters	Q1	Parameters	Q1
IS	8e-17	MJC	0.53
BF	128	XCJC	0.27
NF	1	CJS	0
VAF	17	VJS	0.75
IKF	0.18	MJS	0
ISE	3.3e-15	FC	0.37
NE	1.48	TF	6e-12
BR	9.05	XTF	11.9
NR	1.05	VTF	9.55
VAR	4.3	ITF	1.78
IKR	0.009	PTF	69.1
ISC	4e-15	TR	1e-9
NC	1.5	EG	1.11
RE	0.8	XTB	0
RB	11.1	XTI	3
RBM	2.46	KF	0
IRB	0.017	AF	1
RC	7.5		
CJE	0.415e-12		
VJE	0.68		
MJE	0.53		
CJC	0.102e-12		
VJC	0.29		

(1) Gummel-Poon Model

UNITS

Parameter	Units
time	seconds
capacitance	farads
inductance	henries
resistance	ohms
voltage	volts
current	amps

ADDITIONAL PARAMETERS

Parameters	68730
CCB	0.26e-12
CCE	0.19e-12
LB	0.5e-9
LE	1.07e-9
CCBPKG	0.08e-12
CCEPKG	0.04e-12
CBEPKG	0.04e-12
LBX	0.2e-9
LCX	0.1e-9
LEX	0.2e-9

MODEL RANGE

Frequency: 0.05 to 3.0 GHz
 Bias: VCE = 1 V to 2 V, IC = 1 mA to 10 mA
 Date: 10/25/96

NE68733 NONLINEAR MODEL

SCHEMATIC

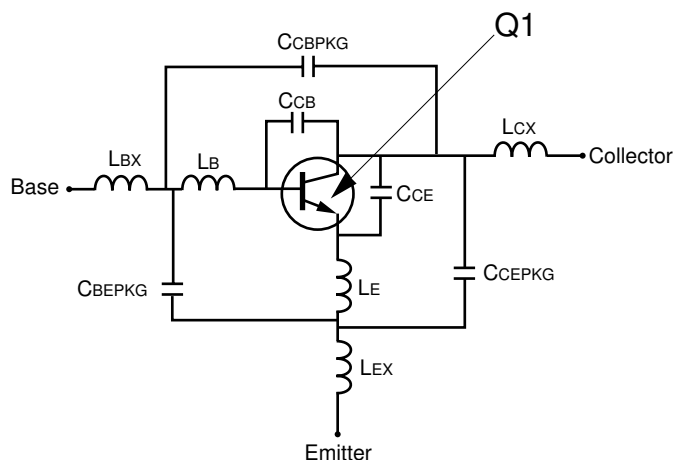

BJT NONLINEAR MODEL PARAMETERS (1)

Parameters	Q1	Parameters	Q1
IS	8e-17	MJC	0.53
BF	128	XCJC	0.27
NF	1	CJS	0
VAF	17	VJS	0.75
IKF	0.18	MJS	0
ISE	3.3e-15	FC	0.37
NE	1.48	TF	6e-12
BR	9.05	XTF	11.9
NR	1.05	VTF	9.55
VAR	4.3	ITF	1.78
IKR	0.009	PTF	69.1
ISC	4e-15	TR	1e-9
NC	1.5	EG	1.11
RE	0.8	XTB	0
RB	11.1	XTI	3
RBM	2.46	KF	0
IRB	0.017	AF	1
RC	7.5		
CJE	0.415e-12		
VJE	0.68		
MJE	0.53		
CJC	0.102e-12		
VJC	0.29		

(1) Gummel-Poon Model

UNITS

Parameter	Units
time	seconds
capacitance	farads
inductance	henries
resistance	ohms
voltage	volts
current	amps

ADDITIONAL PARAMETERS

Parameters	68733
CCB	0.26e-12
CCE	0.19e-12
LB	0.96e-9
LE	1.05e-9
CCBPKG	0.15e-12
CCEPKG	0.09e-12
CBEPKG	0.09e-12
LBX	0.3e-9
LCX	0.3e-9
LEX	0.3e-9

MODEL RANGE

Frequency: 0.05 to 5.0 GHz
 Bias: VCE = 1 V to 2 V, IC = 1 mA to 10 mA
 Date: 7/97

Note:

This nonlinear model utilized the latest data available. See our Design Parameter Library at www.cel.com for this data.

OUTLINE DIMENSIONS¹ (Units in mm)

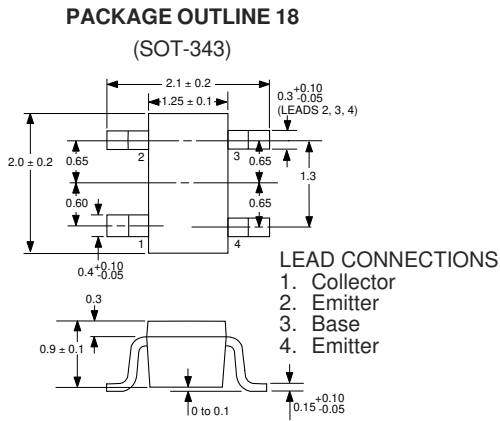

OUTLINE 18
RECOMMENDED P.C.B. LAYOUT

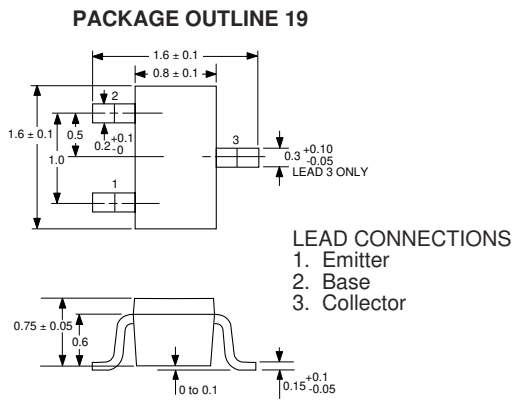
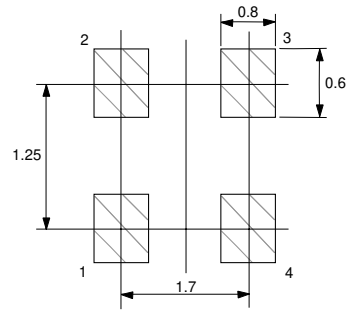

OUTLINE 19
RECOMMENDED P.C.B. LAYOUT

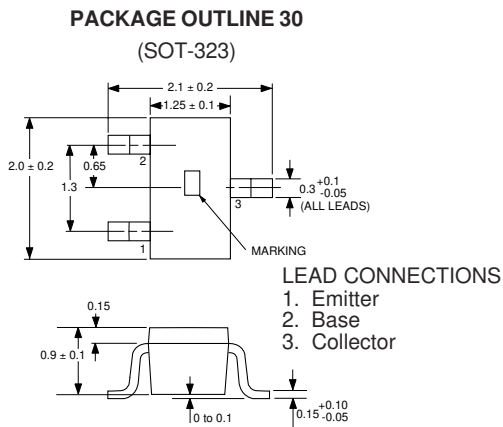
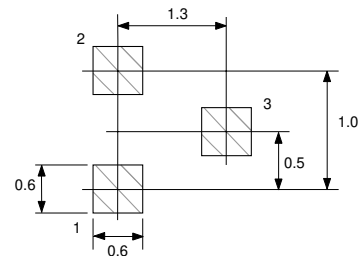

OUTLINE 30
RECOMMENDED P.C.B. LAYOUT

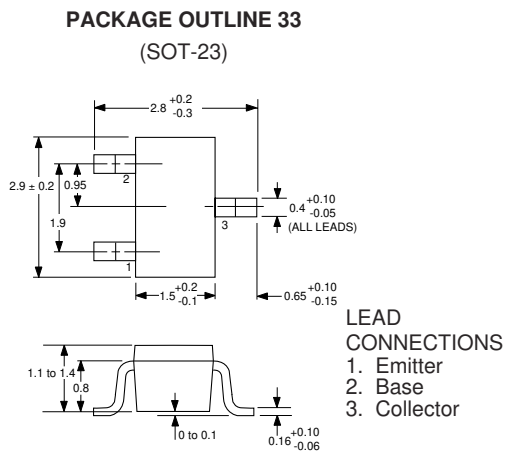
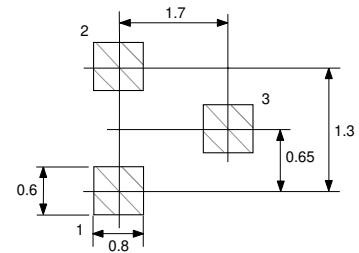

OUTLINE 33
RECOMMENDED P.C.B. LAYOUT

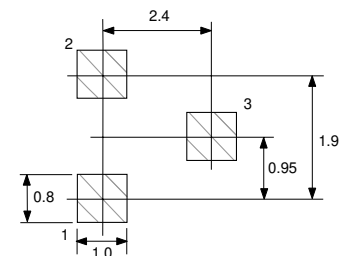

OUTLINE DIMENSIONS¹ (Units in mm)

PACKAGE OUTLINE 39
(SOT-143)

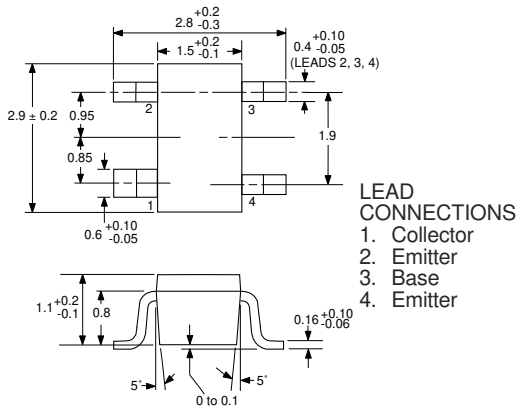

OUTLINE 39
RECOMMENDED P.C.B. LAYOUT

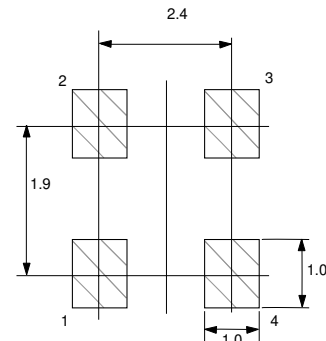

PACKAGE OUTLINE 39R
(SOT-143)

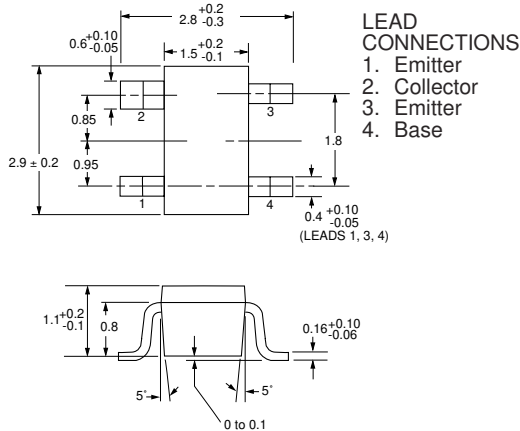

OUTLINE 39R
RECOMMENDED P.C.B. LAYOUT

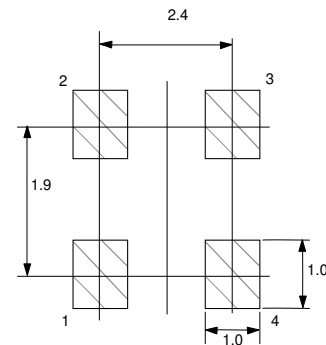

ORDERING INFORMATION

PART NUMBER	QUANTITY	PACKAGING
NE68718-T1	3000	Tape & Reel
NE68719-T1	3000	Tape & Reel
NE68730-T1	3000	Tape & Reel
NE68733-T1	3000	Tape & Reel
NE68739-T1	3000	Tape & Reel
NE68739R-T1	3000	Tape & Reel

Note:

- Lead material: Cu
Lead plating: PbSn

Life Support Applications

These NEC products are not intended for use in life support devices, appliances, or systems where the malfunction of these products can reasonably be expected to result in personal injury. The customers of CEL using or selling these products for use in such applications do so at their own risk and agree to fully indemnify CEL for all damages resulting from such improper use or sale.

EXCLUSIVE NORTH AMERICAN AGENT FOR **NEC** RF, MICROWAVE & OPTOELECTRONIC SEMICONDUCTORS

CEL CALIFORNIA EASTERN LABORATORIES • Headquarters • 4590 Patrick Henry Drive • Santa Clara, CA 95054-1817 • (408) 988-3500 • Telex 34-6393 • FAX (408) 988-0279
DATA SUBJECT TO CHANGE WITHOUT NOTICE

Internet: <http://WWW.CEL.COM>

04/24/2002