



Chipsmall Limited consists of a professional team with an average of over 10 year of expertise in the distribution of electronic components. Based in Hongkong, we have already established firm and mutual-benefit business relationships with customers from,Europe,America and south Asia,supplying obsolete and hard-to-find components to meet their specific needs.

With the principle of “Quality Parts,Customers Priority,Honest Operation,and Considerate Service”,our business mainly focus on the distribution of electronic components. Line cards we deal with include Microchip,ALPS,ROHM,Xilinx,Pulse,ON,Everlight and Freescale. Main products comprise IC,Modules,Potentiometer,IC Socket,Relay,Connector.Our parts cover such applications as commercial,industrial, and automotives areas.

We are looking forward to setting up business relationship with you and hope to provide you with the best service and solution. Let us make a better world for our industry!



## Contact us

Tel: +86-755-8981 8866 Fax: +86-755-8427 6832

Email & Skype: info@chipsmall.com Web: www.chipsmall.com

Address: A1208, Overseas Decoration Building, #122 Zhenhua RD., Futian, Shenzhen, China



## LOW TO MEDIUM POWER AC/DC POWER SUPPLIES

1

- NFS25 and NFS40
- Assembly instructions
- Mounting screws
- Crimp terminals and mating connectors



## MECHANICAL SPECIFICATIONS

### NFS25 and NFS40

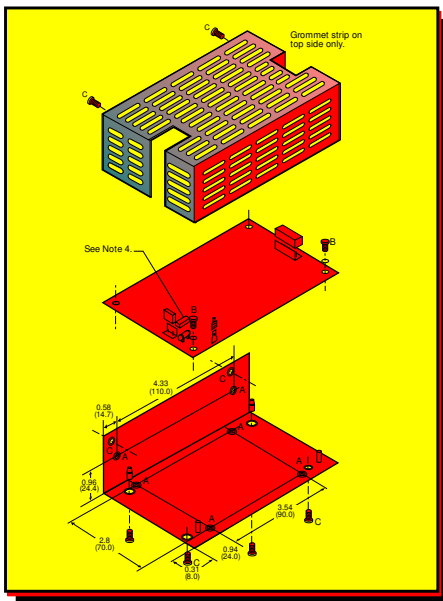

#### Assembly Notes

- 1 Before assembly, ensure unit has been turned off for at least 10 minutes.
- 2 Cover cable exit area with grommet strip provided.
- 3 Maximum screw penetration into customer mounting holes is 3mm.
- 4 Cover fuse with fuse cover provided.
- 5 "A" denotes customer M3 mounting holes.
- 6 "B" denotes PCB fixing screws.
- 7 "C" denotes case assembly points and screws.

**Note:** When a cover or other sheetmetal option is added, it is the user's responsibility to ensure that the requirements of the relevant safety agency, or agencies, are satisfied.

#### MODEL NUMBER: NFS40 COVER KIT

Bracket outside dim. 5.49" x 3.43" x 1.88" (139.5 x 87.2 x 47.9mm)

Cover outside dim. 5.49" x 3.38" x 1.82" (139.5 x 85.8 x 46.3mm)

- **NFS110**
- **Assembly instructions**
- **Mounting screws**
- **Crimp terminals and mating connectors**

The 'NFS110 COVER KIT' is manufactured in Europe with metric screw threads and the kit includes assembly screws and installation instructions.

## MECHANICAL SPECIFICATIONS

### NFS110

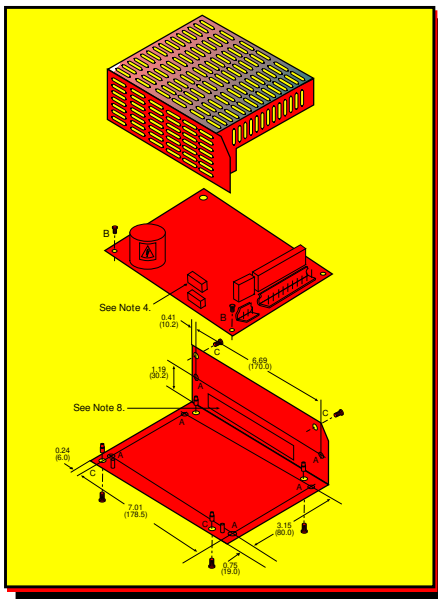

#### Assembly Notes

- 1 Before assembly, ensure unit has been turned off for at least 10 minutes.
- 2 Cover cable exit area with grommet strip provided (optional). Not required for the NFS110.
- 3 Maximum screw penetration into customer mounting holes is 3mm.
- 4 Cover fuse with fuse cover provided.
- 5 "A" denotes customer M3 mounting holes.
- 6 "B" denotes PCB fixing screws.
- 7 "C" denotes case assembly points and screws.
- 8 Apply tape in location shown.
- 9 Dimensions are in inches (mm).

**Note:** When a cover or other sheetmetal option is added, it is the user's responsibility to ensure that the requirements of the relevant safety agency, or agencies, are satisfied.

#### MODEL NUMBER: NFS110 COVER KIT

Bracket outside dim: 7.5" x 4.57" x 2.38" (190.5 x 116 x 60.5mm)

Cover outside dim: 7.5" x 4.51" x 2.32" (190.5 x 114.5 x 59mm)

- NFS110 cover
- Assembly instructions
- Mounting screws

The 'NFS110C' is manufactured in Asia with imperial screw threads and the kit includes assembly screws and installation instructions.

## MECHANICAL SPECIFICATIONS

### NFS110

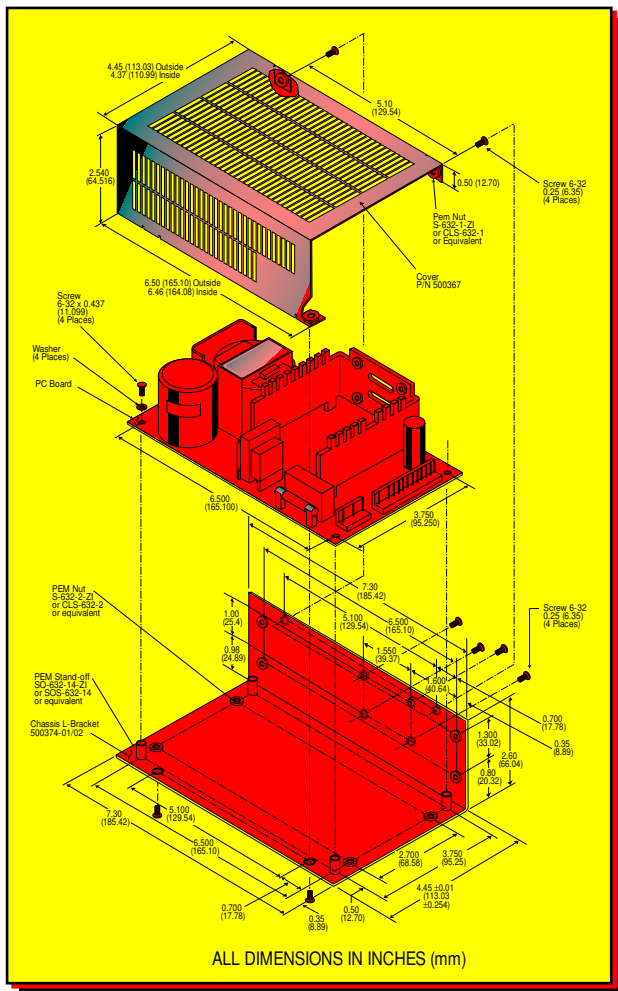

### MODEL NUMBER: NFS110C

Bracket outside dim: 7.3" x 4.45" x 2.6" (185.42 x 113.03 x 66.04mm)  
 Cover outside dim: 6.5" x 4.45" x 2.54" (165.10 x 113.03 x 64.52mm)

Data Sheet © Artesyn Technologies® 2002

The information and specifications contained in this data sheet are believed to be correct at time of publication. However, Artesyn Technologies accepts no responsibility for consequences arising from printing errors or inaccuracies. Specifications are subject to change without notice. No rights under any patent accompany the sale of any such product(s) or information contained herein.