



Chipsmall Limited consists of a professional team with an average of over 10 year of expertise in the distribution of electronic components. Based in Hongkong, we have already established firm and mutual-benefit business relationships with customers from,Europe,America and south Asia,supplying obsolete and hard-to-find components to meet their specific needs.

With the principle of "Quality Parts,Customers Priority,Honest Operation,and Considerate Service",our business mainly focus on the distribution of electronic components. Line cards we deal with include Microchip,ALPS,ROHM,Xilinx,Pulse,ON,Everlight and Freescale. Main products comprise IC,Modules,Potentiometer,IC Socket,Relay,Connector.Our parts cover such applications as commercial,industrial, and automotives areas.

We are looking forward to setting up business relationship with you and hope to provide you with the best service and solution. Let us make a better world for our industry!



Contact us

Tel: +86-755-8981 8866 Fax: +86-755-8427 6832

Email & Skype: info@chipsmall.com Web: www.chipsmall.com

Address: A1208, Overseas Decoration Building, #122 Zhenhua RD., Futian, Shenzhen, China



NHD-0220JZ-FL-GBW

Character Liquid Crystal Display Module

NHD- Newhaven Display
0220- 2 lines x 20 characters
JZ- Model
F- Transflective
L- Yellow/Green LED Backlight
G- STN- Gray
B- 6:00 view
W- Wide Temp. (-20°C~+70°C)
RoHS Compliant

Newhaven Display International, Inc.

2511 Technology Drive, Suite 101

Elgin IL, 60124

Ph: 847-844-8795

Fax: 847-844-8796

www.newhavendisplay.com

nhtech@newhavendisplay.com

nhsales@newhavendisplay.com

Document Revision History

Revision	Date	Description	Changed by
0	10/21/2008	Initial Release	-
1	2/11/2010	User Guide Reformat	MC
2	6/3/2010	Character code updated	BE

Functions and Features

- 2 lines x 20 characters
- Built-in controllers (S6A0069 or equivalent)
- +5.0V Power Supply
- 1/16 duty, 1/5 bias
- RoHS compliant

Mechanical Drawing

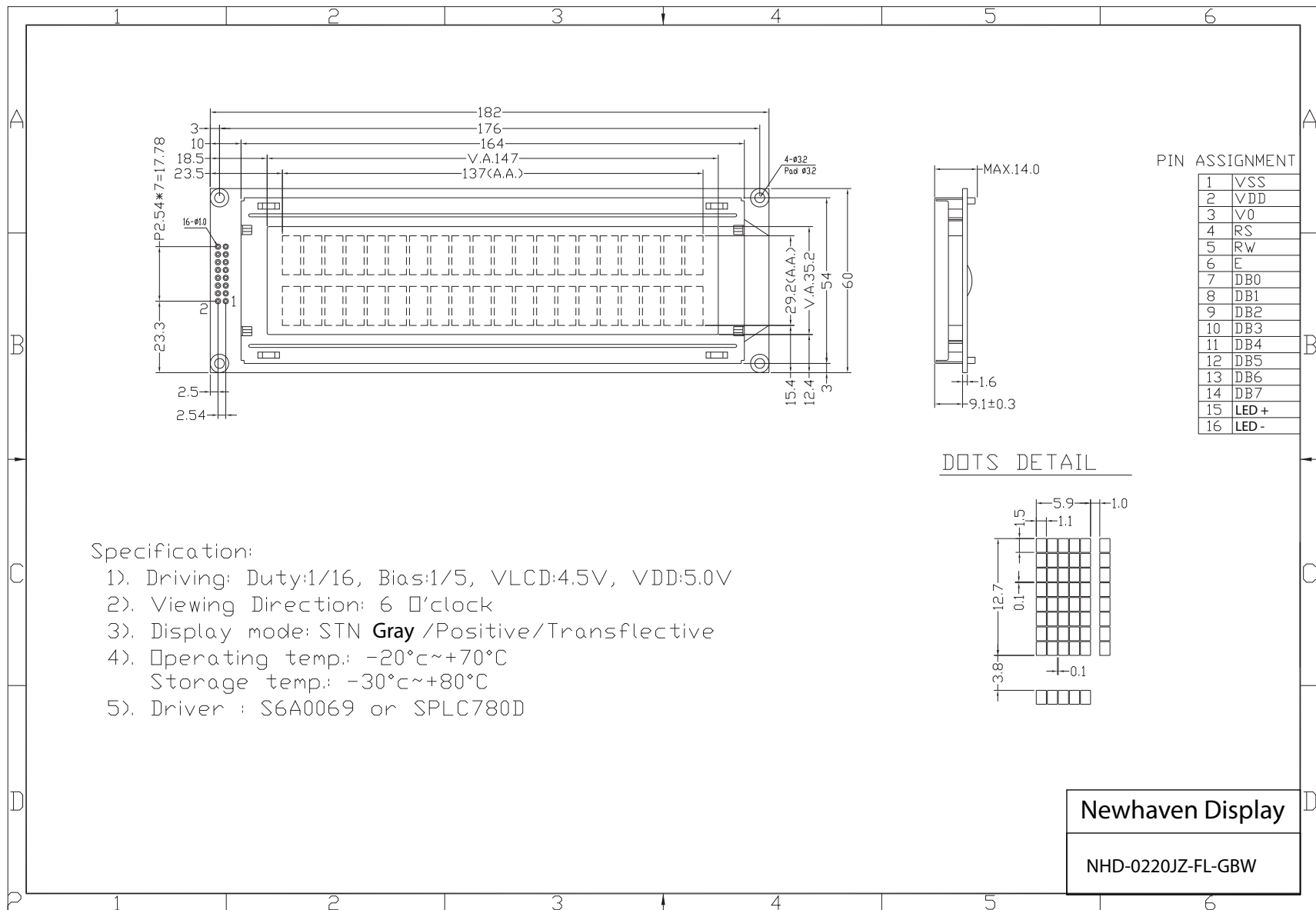

Pin Description and Wiring Diagram

Pin No.	Symbol	External Connection	Function Description
1	Vss	Power Supply	Ground
2	VDD	Power Supply	Supply voltage for logic (+5.0V)
3	V0	Power Supply	Power supply for contrast (approx. 0.4V)
4	RS	MPU	Register select signal. RS=0: Command, RS=1: Data
5	R/W	MPU	Read/Write select signal, R/W=1: Read R/W:=0: Write
6	E	MPU	Operation enable signal. Falling edge triggered.
7-10	DB0-DB3	MPU	Four low order bi-directional three-state data bus lines. These four are no used during 4-bit operation.
11-14	DB4-DB7	MPU	Four high order bi-directional three-state data bus lines.
15	LED+	Power Supply	Power supply for LED Backlight (+5.0 via on-board resistor)
16	LED-	Power Supply	Ground for backlight

Recommended LCD connector: 2.54mm pitch pins

Backlight connector: --- Mates with: ---

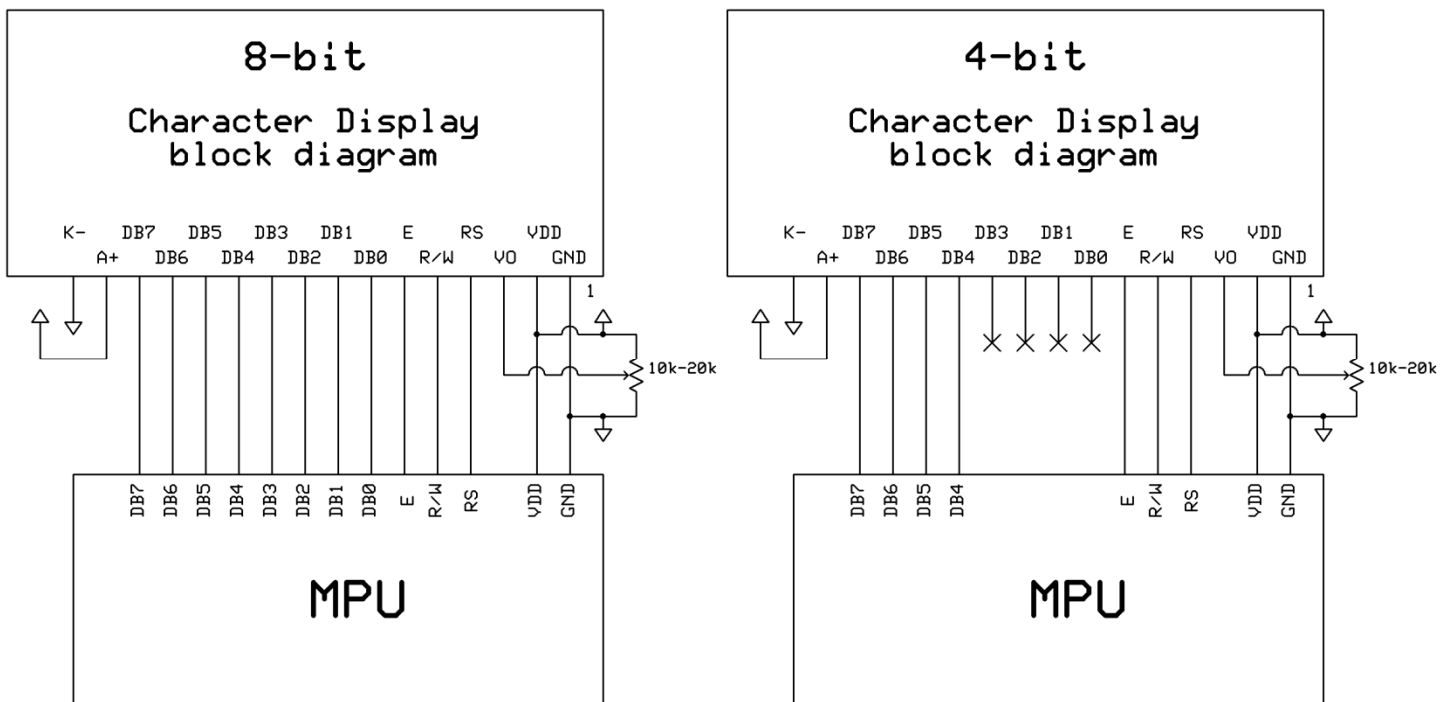

Electrical Characteristics

Item	Symbol	Condition	Min.	Typ.	Max.	Unit
Operating Temperature Range	Top	Absolute Max	-20	-	+70	°C
Storage Temperature Range	Tst	Absolute Max	-30	-	+80	°C
Supply Voltage	VDD		4.7	5.0	5.5	V
Supply Current	IDD	Ta=25°C, VDD=5.0V	-	1.5	2.5	mA
Supply for LCD (contrast)	VDD-V0	Ta=25°C	-	4.6	-	V
"H" Level input	Vih		2.2	-	VDD	V
"L" Level input	Vil		0	-	0.6	V
"H" Level output	Voh		2.4	-	-	V
"L" Level output	Vol		-	-	0.4	V
Backlight Supply Voltage	Vled	-	-	5.0	-	V
Backlight Supply Current	Iled	Vled=5.0V	-	300	-	mA

Optical Characteristics

Item	Symbol	Condition	Min.	Typ.	Max.	Unit
Viewing Angle – Vertical (top)	AV	Cr ≥ 2	-	25	-	°
Viewing Angle – Vertical (bottom)	AV	Cr ≥ 2	-	70	-	°
Viewing Angle – Horizontal (left)	AH	Cr ≥ 2	-	30	-	°
Viewing Angle – Horizontal (right)	AH	Cr ≥ 2	-	30	-	°
Contrast Ratio	Cr		-	2	-	-
Response Time (rise)	Tr	-	-	120	150	ms
Response Time (fall)	Tf	-	-	120	150	ms

Controller Information

Built-in S6A0069. Download specification at http://www.newhavendisplay.com/app_notes/S6A0069.pdf

Table of Commands

Instruction	Instruction Code											Description	Execution time (fosc=270KHz)
	RS	R/W	DB7	DB6	DB5	DB4	DB3	DB2	DB1	DB0			
Clear Display	0	0	0	0	0	0	0	0	0	0	1	Write "20H" to DDRAM and set DDRAM address to "00H" from AC	1.52ms
Return Home	0	0	0	0	0	0	0	0	0	1	-	Set DDRAM address to "00H" from AC and return cursor to its original position if shifted. The contents of DDRAM are not changed.	1.52ms
Entry Mode Set	0	0	0	0	0	0	0	0	1	I/D	S	Assign cursor moving direction and enable the shift of entire display	38 μ s
Display ON/OFF Control	0	0	0	0	0	0	0	1	D	C	B	Set display(D), cursor(C), and blinking of cursor(B) on/off control bit.	38 μ s
Cursor or Display Shift	0	0	0	0	0	1	S/C	R/L	-	-	-	Set cursor moving and display shift control bit, and the direction, without changing of DDRAM data.	38 μ s
Function Set	0	0	0	0	1	DL	N	F	-	-	-	Set interface data length (DL: 8bit/4-bit), numbers of display line (N: 2-line/1-line) and, display font type (F:5x10 dots/5x8 dots)	38 μ s
Set CGRAM Address	0	0	0	1	AC5	AC4	AC3	AC2	AC1	AC0		Set CGRAM address in address counter.	38 μ s
Set DDRAM Address	0	0	1	AC6	AC5	AC4	AC3	AC2	AC1	AC0		Set DDRAM address in counter	38 μ s
Read Busy Flag and Address Counter	0	1	BF	AC6	AC5	AC4	AC3	AC2	AC1	AC0		Whether during internal operation or not can be known by reading BF. The contents of address counter can also be read.	
Write Data to RAM	1	0	D7	D6	D5	D4	D3	D2	D1	D0		Write data into internal RAM (DDRAM/CGRAM).	38 μ s
Read Data from RAM	1	1	D7	D6	D5	D4	D3	D2	D1	D0		Read data from internal RAM (DDRAM/CGRAM).	38 μ s

Display character address code:

1	2	3	4	5	6	7	8	9	10	11	12	13	14	15	16	17	18	19	20
00	01	02	03	04	05	06	07	08	09	0A	0B	0C	0D	0E	0F	10	11	12	13
40	41	42	43	44	45	46	47	48	49	4A	4B	4C	4D	4E	4F	50	51	52	53

Timing Characteristics

Write mode (Writing data from MPU to S6A0069)

Characteristics	Symbol	Limit			Unit	Test Condition
		Min.	Typ.	Max.		
E Cycle Time	t_c	500	-	-	ns	Pin E
E Pulse Width	t_{PW}	230	-	-	ns	Pin E
E Rise/Fall Time	t_r, t_f	-	-	20	ns	Pin E
Address Setup Time	t_{SP1}	40	-	-	ns	Pins: RS, R/W, E
Address Hold Time	t_{HD1}	10	-	-	ns	Pins: RS, R/W, E
Data Setup Time	t_{SP2}	80	-	-	ns	Pins: DB0 - DB7
Data Hold Time	t_{HD2}	10	-	-	ns	Pins: DB0 - DB7

Write mode timing diagram (Writing data from MPU to S6A0069)

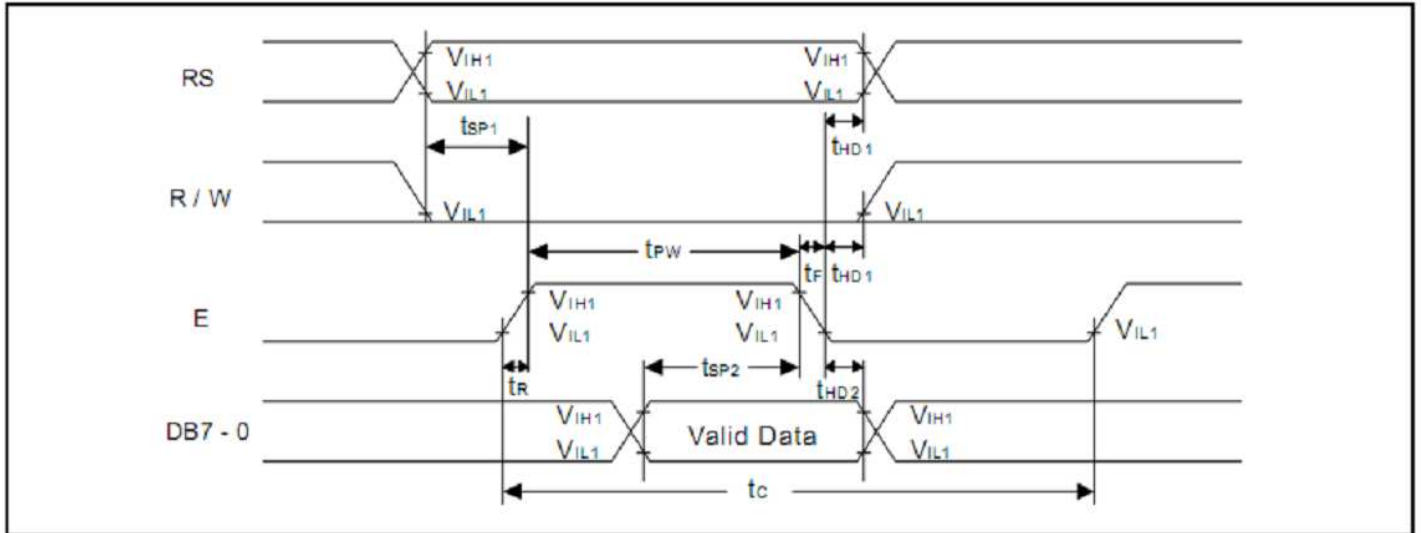

Read mode (Reading data from MPU to S6A0069)

Characteristics	Symbol	Limit			Unit	Test Condition
		Min.	Typ.	Max.		
E Cycle Time	t_c	1000	-	-	ns	Pin E
E Pulse Width	t_w	450	-	-	ns	Pin E
E Rise/Fall Time	t_R, t_F	-	-	25	ns	Pin E
Address Setup Time	t_{SP1}	60	-	-	ns	Pins: RS, R/W, E
Address Hold Time	t_{HD1}	20	-	-	ns	Pins: RS, R/W, E
Data Output Delay Time	t_D	-	-	360	ns	Pins: DB0 - DB7
Data hold time	t_{HD2}	5.0	-	-	ns	Pin DB0 - DB7

Read mode timing diagram (Reading from MPU to S6A0069)

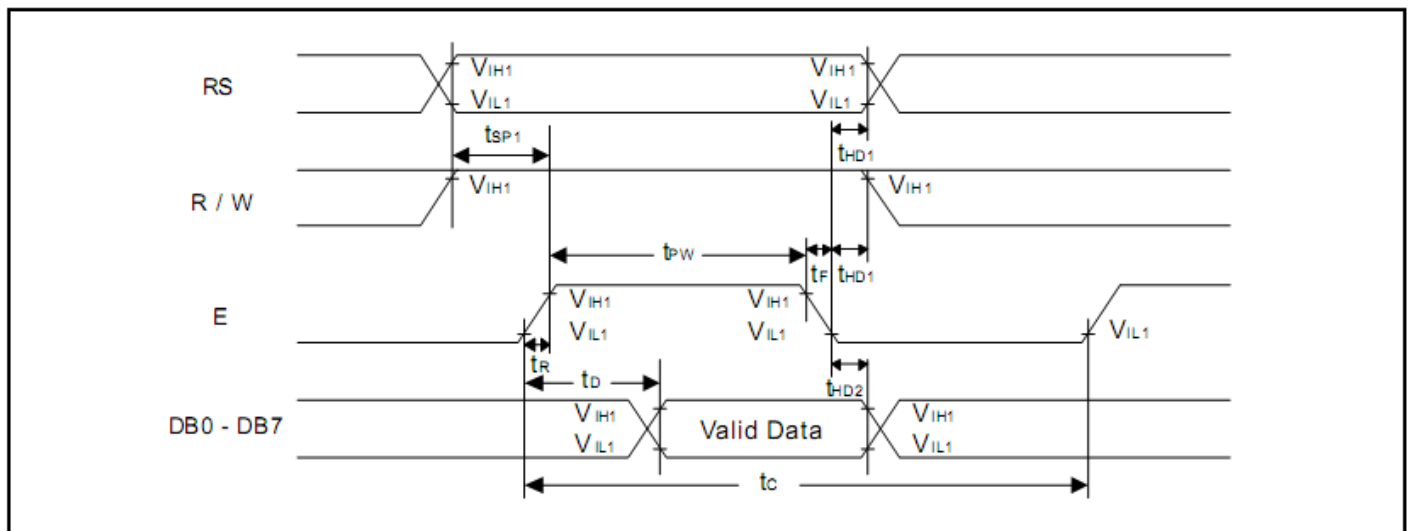

Built-in Font Table

Lower 4 Bits \ Upper 4 Bits	0000	0001	0010	0011	0100	0101	0110	0111	1000	1001	1010	1011	1100	1101	1110	1111
xxxx0000	CG RAM (1)			0	a	P	`	P				-	タ	ミ	&	P
xxxx0001	(2)		!	1	A	Q	a	q			。	ア	チ	△	ö	q
xxxx0010	(3)		"	2	B	R	b	r			「	イ	ツ	×	ß	θ
xxxx0011	(4)		#	3	C	S	c	s			」	ウ	テ	モ	ε	ε
xxxx0100	(5)		\$	4	D	T	d	t			、	エ	ト	ト	μ	Ω
xxxx0101	(6)		%	5	E	U	e	u			・	オ	ナ	1	ε	ü
xxxx0110	(7)		&	6	F	V	f	v			ヲ	カ	ニ	ヨ	ρ	Σ
xxxx0111	(8)		'	7	G	W	g	w			ア	キ	ヌ	ラ	g	π
xxxx1000	(1)		<	8	H	X	h	x			イ	ク	ネ	リ	√	×
xxxx1001	(2)		>	9	I	Y	i	y			ウ	ケ	ル	ル	ˆ	γ
xxxx1010	(3)		*	:	J	Z	j	z			エ	コ	ハ	レ	j	≠
xxxx1011	(4)		+	;	K	[k	[オ	サ	ヒ	ロ	*	≠
xxxx1100	(5)		,	<	L	¥	l	l			カ	シ	フ	ク	φ	≠
xxxx1101	(6)		-	=	M]	m]			ユ	ス	ハ	ン	も	÷
xxxx1110	(7)		.	>	N	^	n	→			ヨ	セ	ホ	°	ñ	
xxxx1111	(8)		/	?	O	_	o	←			ッ	リ	マ	°	ö	■

Example Initialization Program

```
8-bit Initialization:
/*****/
void command(char i)
{
    P1 = i;                //put data on output Port
    D_I =0;                //D/I=LOW : send instruction
    R_W =0;                //R/W=LOW : Write
    E = 1;
    Delay(1);              //enable pulse width >= 300ns
    E = 0;                 //Clock enable: falling edge
}
/*****/
void write(char i)
{
    P1 = i;                //put data on output Port
    D_I =1;                //D/I=LOW : send data
    R_W =0;                //R/W=LOW : Write
    E = 1;
    Delay(1);              //enable pulse width >= 300ns
    E = 0;                 //Clock enable: falling edge
}
/*****/
void init()
{
    E = 0;
    Delay(100);            //Wait >15 msec after power is applied
    command(0x30);         //command 0x30 = Wake up
    Delay(30);             //must wait 5ms, busy flag not available
    command(0x30);         //command 0x30 = Wake up #2
    Delay(10);             //must wait 160us, busy flag not available
    command(0x30);         //command 0x30 = Wake up #3
    Delay(10);             //must wait 160us, busy flag not available
    command(0x38);         //Function set: 8-bit/2-line
    command(0x10);         //Set cursor
    command(0x0c);         //Display ON; Cursor ON
    command(0x06);         //Entry mode set
}
/*****/
```

4-bit Initialization:

```

/*****/
void command(char i)
{
    P1 = i;                //put data on output Port
    D_I =0;               //D/I=LOW : send instruction
    R_W =0;               //R/W=LOW : Write
    Nybble();             //Send lower 4 bits
    i = i<<4;             //Shift over by 4 bits
    P1 = i;                //put data on output Port
    Nybble();             //Send upper 4 bits
}
/*****/
void write(char i)
{
    P1 = i;                //put data on output Port
    D_I =1;               //D/I=HIGH : send data
    R_W =0;               //R/W=LOW : Write
    Nybble();             //Clock lower 4 bits
    i = i<<4;             //Shift over by 4 bits
    P1 = i;                //put data on output Port
    Nybble();             //Clock upper 4 bits
}
/*****/
void Nybble()
{
    E = 1;
    Delay(1);             //enable pulse width >= 300ns
    E = 0;                //Clock enable: falling edge
}
/*****/
void init()
{
    P1 = 0;
    P3 = 0;
    Delay(100);           //Wait >15 msec after power is applied
    P1 = 0x30;            //put 0x30 on the output port
    Delay(30);            //must wait 5ms, busy flag not available
    Nybble();             //command 0x30 = Wake up
    Delay(10);            //must wait 160us, busy flag not available
    Nybble();             //command 0x30 = Wake up #2
    Delay(10);            //must wait 160us, busy flag not available
    Nybble();             //command 0x30 = Wake up #3
    Delay(10);            //can check busy flag now instead of delay
    P1= 0x20;             //put 0x20 on the output port
    Nybble();             //Function set: 4-bit interface
    command(0x28);        //Function set: 4-bit/2-line
    command(0x10);        //Set cursor
    command(0x0F);        //Display ON; Blinking cursor
    command(0x06);        //Entry Mode set
}
/*****/

```

Quality Information

Test Item	Content of Test	Test Condition	Note
High Temperature storage	Endurance test applying the high storage temperature for a long time.	+80°C , 48hrs	2
Low Temperature storage	Endurance test applying the low storage temperature for a long time.	-30°C , 48hrs	1,2
High Temperature Operation	Endurance test applying the electric stress (voltage & current) and the high thermal stress for a long time.	+70°C 48hrs	2
Low Temperature Operation	Endurance test applying the electric stress (voltage & current) and the low thermal stress for a long time.	-20°C , 48hrs	1,2
High Temperature / Humidity Operation	Endurance test applying the electric stress (voltage & current) and the high thermal with high humidity stress for a long time.	+40°C , 90% RH , 48hrs	1,2
Thermal Shock resistance	Endurance test applying the electric stress (voltage & current) during a cycle of low and high thermal stress.	0°C,30min -> 25°C,5min -> 50°C,30min = 1 cycle 10 cycles	
Vibration test	Endurance test applying vibration to simulate transportation and use.	10-55Hz , 15mm amplitude. 60 sec in each of 3 directions X,Y,Z For 15 minutes	3
Static electricity test	Endurance test applying electric static discharge.	VS=800V, RS=1.5kΩ, CS=100pF One time	

Note 1: No condensation to be observed.

Note 2: Conducted after 4 hours of storage at 25°C, 0%RH.

Note 3: Test performed on product itself, not inside a container.

Precautions for using LCDs/LCMs

See Precautions at www.newhavendisplay.com/specs/precautions.pdf

Warranty Information and Terms & Conditions

http://www.newhavendisplay.com/index.php?main_page=terms