



Chipsmall Limited consists of a professional team with an average of over 10 year of expertise in the distribution of electronic components. Based in Hongkong, we have already established firm and mutual-benefit business relationships with customers from,Europe,America and south Asia,supplying obsolete and hard-to-find components to meet their specific needs.

With the principle of “Quality Parts,Customers Priority,Honest Operation,and Considerate Service”,our business mainly focus on the distribution of electronic components. Line cards we deal with include Microchip,ALPS,ROHM,Xilinx,Pulse,ON,Everlight and Freescale. Main products comprise IC,Modules,Potentiometer,IC Socket,Relay,Connector.Our parts cover such applications as commercial,industrial, and automotives areas.

We are looking forward to setting up business relationship with you and hope to provide you with the best service and solution. Let us make a better world for our industry!



## Contact us

Tel: +86-755-8981 8866 Fax: +86-755-8427 6832

Email & Skype: info@chipsmall.com Web: www.chipsmall.com

Address: A1208, Overseas Decoration Building, #122 Zhenhua RD., Futian, Shenzhen, China



# NHD-0224WH-ATDI-JT#

## Character Liquid Crystal Display Module

NHD- Newhaven Display  
0224- 2 lines x 24 characters  
WH- Display Type: Character  
A- Model  
T- White LED Backlight  
D- FSTN- Negative (double film)  
I- Transmissive, Wide Temp. 6:00 view  
JT#- English and Japanese standard font  
**RoHS Compliant**

**Newhaven Display International, Inc.**

2511 Technology Drive, Suite 101

Elgin IL, 60124

Ph: 847-844-8795

Fax: 847-844-8796

[www.newhavendisplay.com](http://www.newhavendisplay.com)

[nhtech@newhavendisplay.com](mailto:nhtech@newhavendisplay.com)

[nhsales@newhavendisplay.com](mailto:nhsales@newhavendisplay.com)

## Document Revision History

Revision	Date	Description	Changed by
0	7/24/2009	Initial Release	-
1	7/27/2009	User Guide Reformat	BE
2	11/2/2009	Block Diagram Revision	BE
3	5/20/2011	Controller information updated	AK
4	6/8/2011	Mechanical drawing updated	BE

## Functions and Features

- 2 lines x 24 characters
- Built-in controller (ST7066U)
- +5.0V power supply
- 1/16 duty, 1/5 bias

# Mechanical Drawing

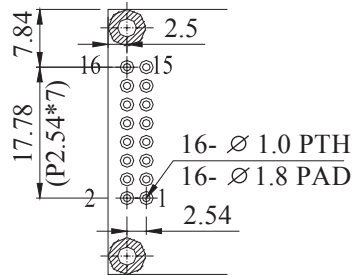
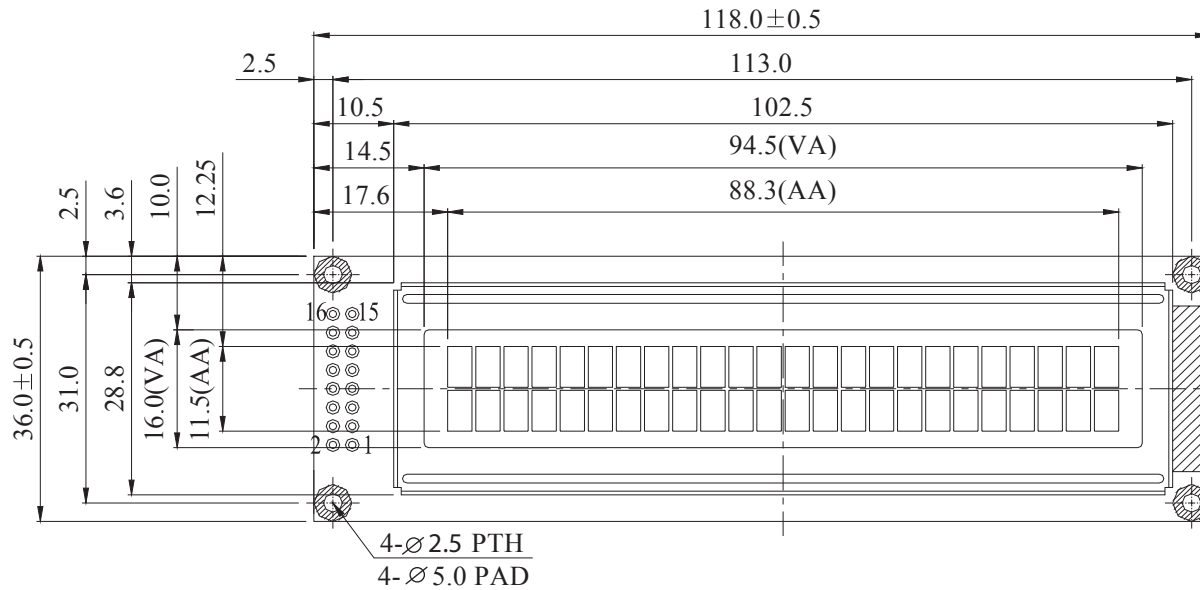

PIN DETAIL  
SCALE 1/1

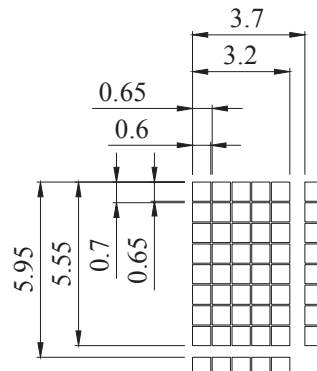

DOT SIZE  
SCALE 5/1

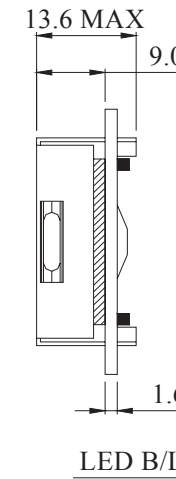

PIN NO.	SYMBOL
1	V <sub>ss</sub>
2	V <sub>dd</sub>
3	V <sub>o</sub>
4	RS
5	R/W
6	E
7	DB0
8	DB1
9	DB2
10	DB3
11	DB4
12	DB5
13	DB6
14	DB7
15	LED+
16	LED-

Newhaven Display  
NHD-0224WH-ATDI-JT#

## Pin Description and Wiring Diagram

Pin No.	Symbol	External Connection	Function Description
1	$V_{SS}$	Power Supply	Ground
2	$V_{DD}$	Power Supply	Supply Voltage for logic (5.0V)
3	$V_0$	Adj Power Supply	Power supply for contrast (approx. 0.5V)
4	RS	MPU	Register select signal. RS=0: Command, RS=1: Data
5	R/W	MPU	Read/Write select signal, R/W=1: Read R/W: =0: Write
6	E	MPU	Operation enable signal. Falling edge triggered.
7-10	DB0-DB3	MPU	Four low order bi-directional three-state data bus lines. These four are not used during 4-bit operation.
11-14	DB4 – DB7	MPU	Four high order bi-directional three-state data bus lines.
15	LED+	Power Supply	Power supply for LED Backlight (+3.5V)
16	LED-	Power Supply	Ground for Backlight

**Recommended LCD connector:** 2.54mm pitch, 16-pin dual-row

**Backlight connector:** -

**Mates with:** -

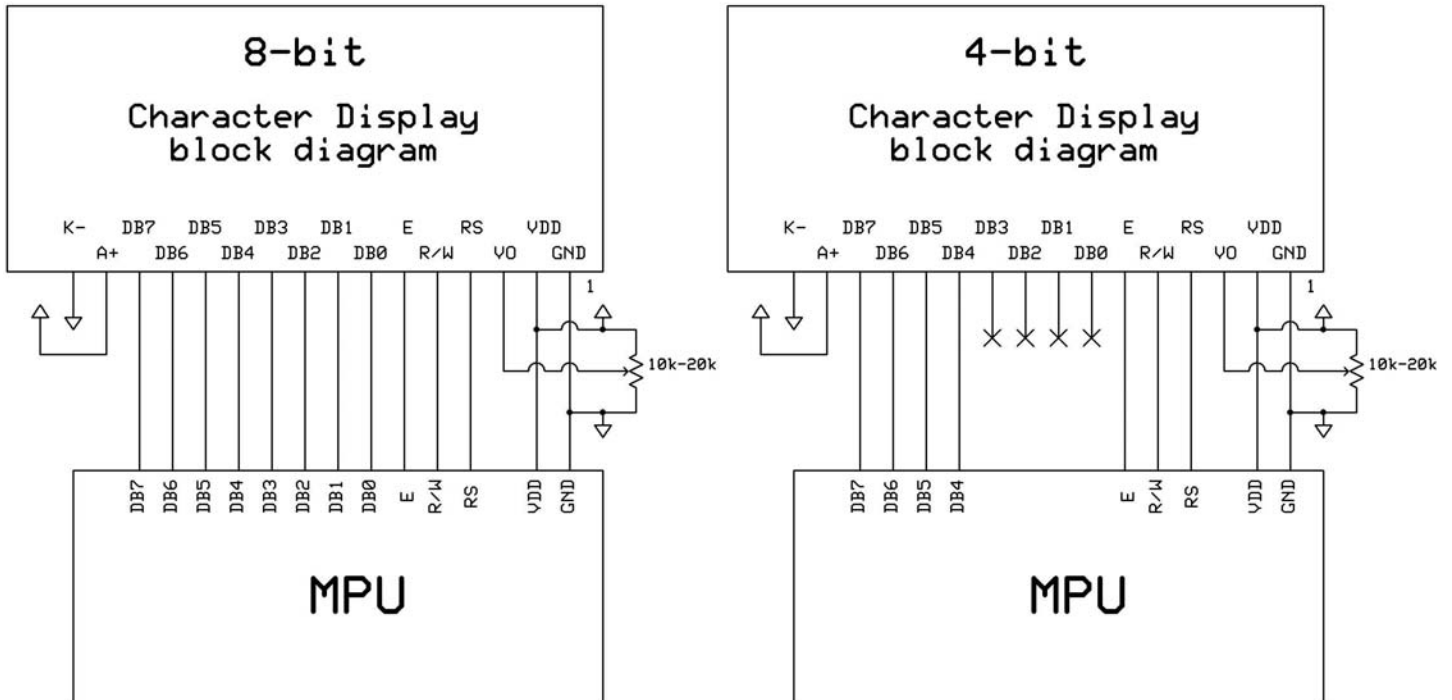



## Electrical Characteristics

Item	Symbol	Condition	Min.	Typ.	Max.	Unit
Operating Temperature Range	Top	Absolute Max	-20	-	+70	°C
Storage Temperature Range	Tst	Absolute Max	-30	-	+80	°C
Supply Voltage	VDD		4.5	5.0	5.5	V
Supply Current	IDD	VDD=5.0V	1.0	1.2	1.5	mA
Supply for LCD (contrast)	VDD-V0	Ta=25°C	3.8	4.5	5.5	V
"H" Level input	Vih		0.7	-	VDD	V
"L" Level input	Vil		Vss	-	0.6	V
"H" Level output	Voh		3.9	-	-	V
"L" Level output	Vol		-	-	0.4	V
Backlight Supply Voltage	Vled	-	3.4	3.5	3.6	V
Backlight Supply Current	Iled	Vled=3.5V	28.8	32	50	mA
Backlight Lifetime		Iled=32	-	50,000	-	Hrs

## Optical Characteristics

Item	Symbol	Condition	Min.	Typ.	Max.	Unit
Viewing Angle – Vertical (top)	AV	Cr ≥ 2	-	25	-	°
Viewing Angle – Vertical (bottom)	AV	Cr ≥ 2	-	70	-	°
Viewing Angle – Horizontal (left)	AH	Cr ≥ 2	-	30	-	°
Viewing Angle – Horizontal (right)	AH	Cr ≥ 2	-	30	-	°
Contrast Ratio	Cr		-	2	-	-
Response Time (rise)	Tr	-	-	120	150	ms
Response Time (fall)	Tf	-	-	120	150	ms

## Controller Information

Built-in ST7066U. Download specification at [http://www.newhavendisplay.com/app\\_notes/ST7066U.pdf](http://www.newhavendisplay.com/app_notes/ST7066U.pdf)

## Display Character Address Code

Character located	1	2	3	4	5	6	-----	19	20	21	22	23	24
DDRAM address	00	01	02	03	04	05	-----	12	13	14	15	16	17
DDRAM address	40	41	42	43	44	45	-----	52	53	54	55	56	57

## Table of Commands

Instruction	Instruction Code										Description	Execution time (fosc=270Khz)	
	RS	R/W	DB7	DB6	DB5	DB4	DB3	DB2	DB1	DB0			
Clear Display	0	0	0	0	0	0	0	0	0	1	Write "00H" to DDRAM and set DDRAM address to "00H" from AC	1.53ms	
Return Home	0	0	0	0	0	0	0	0	0	1	Set DDRAM address to "00H" from AC and return cursor to its original position if shifted. The contents of DDRAM are not changed.	1.53ms	
Entry Mode Set	0	0	0	0	0	0	0	0	1	I/D	SH	Assign cursor moving direction and enable the shift of entire display.	39 $\mu$ s
Display ON/OFF Control	0	0	0	0	0	0	0	1	D	C	B	Set display (D), cursor (C), and blinking of cursor (B) on/off control bit.	39 $\mu$ s
Cursor or Display Shift	0	0	0	0	0	0	1	S/C	R/L	—	—	Set cursor moving and display shift control bit, and the direction, without changing of DDRAM data.	39 $\mu$ s
Function Set	0	0	0	0	0	1	DL	N	F	—	—	Set interface data length (DL:8-bit/4-bit), numbers of display line (N:2-line/1-line)and, display font type (F:5x11 dots/5x8 dots)	39 $\mu$ s
Set CGRAM Address	0	0	0	1	AC5	AC4	AC3	AC2	AC1	AC0		Set CGRAM address in address counter.	39 $\mu$ s
Set DDRAM Address	0	0	1	AC6	AC5	AC4	AC3	AC2	AC1	AC0		Set DDRAM address in address counter.	39 $\mu$ s
Read Busy Flag and Address	0	1	BF	AC6	AC5	AC4	AC3	AC2	AC1	AC0		Whether during internal operation or not can be known by reading BF. The contents of address counter can also be read.	0 $\mu$ s
Write Data to RAM	1	0	D7	D6	D5	D4	D3	D2	D1	D0		Write data into internal RAM (DDRAM/CGRAM).	43 $\mu$ s
Read Data from RAM	1	1	D7	D6	D5	D4	D3	D2	D1	D0		Read data from internal RAM (DDRAM/CGRAM).	43 $\mu$ s

# Timing Characteristics

Read mode timing diagram

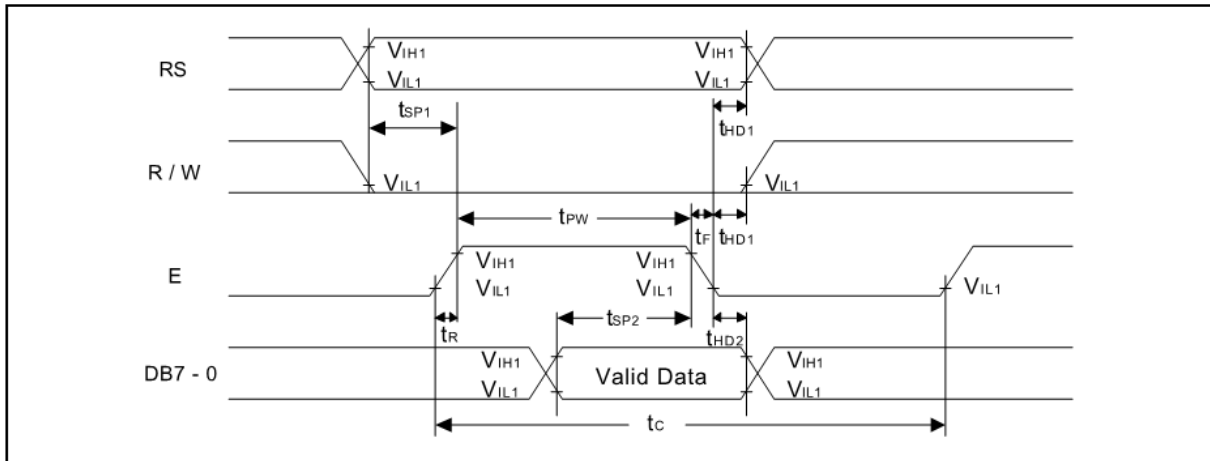

$T_a=25^\circ\text{C}$ ,  $V_{DD}=5.0\text{V}$

Item	Symbol	Min	Typ	Max	Unit
Enable cycle time	$T_C$	1200	—	—	ns
Enable pulse width	$T_{PW}$	140	—	—	ns
Enable rise/fall time	$T_R, T_F$	—	—	25	ns
Address set-up time (RS, R/W to E)	$t_{AS}$	0	—	—	ns
Address hold time	$t_{AH}$	10	—	—	ns
Data set-up time	$t_{DSW}$	40	—	—	ns
Data hold time	$t_H$	10	—	—	ns

Read mode timing diagram

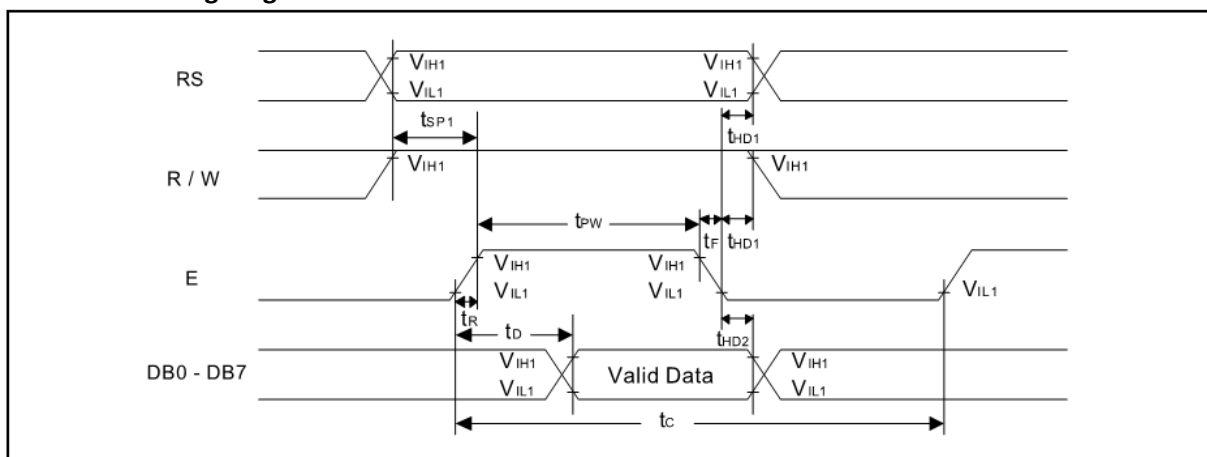



# Built-in Font Table

Upper 4 bit Lower 4 bit	LLLL	LLLH	LLHL	LLHH	LHLL	LHLH	LHHL	LHHH	HLLL	HLLH	HLHL	HLHH	HHLL	HHLH	HHHL	HHHH
LLLL	CG RAM (1)			0	1	2	3	4			5	6	7	8	9	A
LLLH	(2)	!	"	#	\$	%	&	'	(	)	*	+	,	-	.	/
LLHL	(3)	:	;	<	=	>	?	@	[	]	^	_	~			
LLHH	(4)															
LHLL	(5)															
LHLH	(6)															
LHHL	(7)															
LHHH	(8)															
HLLL	(1)															
HLLH	(2)															
HLHL	(3)															
HLHH	(4)															
HHLL	(5)															
HHLH	(6)															
HHHL	(7)															
HHHH	(8)															

## Example Initialization Program

### 4-bit:

```
void command(char i)
{
    P1 = i;
    D_I =0;           //Send Instruction
    R_W =0;
    Nybble();
    i = i<<4;
    P1 = i;
    Nybble();
}
void write(char i)
{
    P1 = i;
    D_I =1;           //Send Data
    R_W =0;
    Nybble();
    i = i<<4;
    P1 = i;
    Nybble();
}
void Nybble()
{
    E = 1;
    Delays(10);      //enable pulse width >= 300ns
    E = 0;
}

void init()
{
    P1 = 0;
    P3 = 0;
    Delays(30);
    P1 = 0x30;        //Wake up
    Delays(100);
    Nybble();
    Delays(100);
    Nybble();
    Delays(10);
    Nybble();        //Wake up three times
    Delays(10);
    P1= 0x20;        //Function set: 4-bit
    Nybble();
    command(0x28);   //Function set: 4-bit/2-line
    command(0x10);   //Set cursor
    command(0x0F);   //Display ON; Blinking cursor
    command(0x06);   //Entry Mode set
}
```

### 8-bit:

```
void command(char i)
{
    P1 = i;
    D_I = 0;           //Send Instruction
    R_W = 0;
    E = 1;
    Delays(1);
    E = 0;
}

void write(char i)
{
    P1 = i;
    D_I = 1;           //Send Data
    R_W = 0;
    E = 1;
    Delays(1);
    E = 0;
}

void init()
{
    E = 0;
    Delays(5);
    command(0x30);     //Wake up
    Delays(100);
    command(0x30);
    Delays(10);
    command(0x30);     //Wake up three times
    Delays(10);
    command(0x38);     //Function set: 8-bit/2-line
    command(0x10);     //Set cursor
    command(0x0c);     //Display ON; Cursor ON
    command(0x06);     //Entry mode set
}
```

## Quality Information

Test Item	Content of Test	Test Condition	Note
High Temperature storage	Endurance test applying the high storage temperature for a long time.	+80°C , 200hrs	2
Low Temperature storage	Endurance test applying the low storage temperature for a long time.	-30°C , 200hrs	1,2
High Temperature Operation	Endurance test applying the electric stress (voltage & current) and the high thermal stress for a long time.	+70°C 200hrs	2
Low Temperature Operation	Endurance test applying the electric stress (voltage & current) and the low thermal stress for a long time.	-20°C , 200hrs	1,2
High Temperature / Humidity Operation	Endurance test applying the electric stress (voltage & current) and the high thermal with high humidity stress for a long time.	+60°C , 90% RH , 96hrs	1,2
Thermal Shock resistance	Endurance test applying the electric stress (voltage & current) during a cycle of low and high thermal stress.	-20°C,30min -> 25°C,5min -> 70°C,30min = 1 cycle 10 cycles	
Vibration test	Endurance test applying vibration to simulate transportation and use.	10-55Hz , 15mm amplitude. 60 sec in each of 3 directions X,Y,Z For 15 minutes	3
Static electricity test	Endurance test applying electric static discharge.	VS=800V, RS=1.5kΩ, CS=100pF One time	

**Note 1:** No condensation to be observed.

**Note 2:** Conducted after 4 hours of storage at 25°C, 0%RH.

**Note 3:** Test performed on product itself, not inside a container.

## Precautions for using LCDs/LCMs

See Precautions at [www.newhavendisplay.com/specs/precautions.pdf](http://www.newhavendisplay.com/specs/precautions.pdf)

## Warranty Information and Terms & Conditions

[http://www.newhavendisplay.com/index.php?main\\_page=terms](http://www.newhavendisplay.com/index.php?main_page=terms)