



Chipsmall Limited consists of a professional team with an average of over 10 year of expertise in the distribution of electronic components. Based in Hongkong, we have already established firm and mutual-benefit business relationships with customers from,Europe,America and south Asia,supplying obsolete and hard-to-find components to meet their specific needs.

With the principle of “Quality Parts,Customers Priority,Honest Operation,and Considerate Service”,our business mainly focus on the distribution of electronic components. Line cards we deal with include Microchip,ALPS,ROHM,Xilinx,Pulse,ON,Everlight and Freescale. Main products comprise IC,Modules,Potentiometer,IC Socket,Relay,Connector.Our parts cover such applications as commercial,industrial, and automotives areas.

We are looking forward to setting up business relationship with you and hope to provide you with the best service and solution. Let us make a better world for our industry!



Contact us

Tel: +86-755-8981 8866 Fax: +86-755-8427 6832

Email & Skype: info@chipsmall.com Web: www.chipsmall.com

Address: A1208, Overseas Decoration Building, #122 Zhenhua RD., Futian, Shenzhen, China



NHD-0240BZ-NSW-BTW-P

Serial Liquid Crystal Display Module

NHD-	Newhaven Display
0240-	2 lines x 40 characters
BZ-	Model
N-	Transmissive
SW-	Side White LED Backlight
B-	STN-Blue (-)
T-	12:00 view
W-	Wide Temperature (-20°C ~ +70°C)
P-	Pin connector
	RoHS Compliant

Newhaven Display International, Inc.

2511 Technology Drive, Suite 101

Elgin IL, 60124

Ph: 847-844-8795

Fax: 847-844-8796

www.newhavendisplay.com

nhtech@newhavendisplay.com

nhsales@newhavendisplay.com

Document Revision History

Revision	Date	Description	Changed by
0	9/25/2007	Initial Release	-
1	6/15/2010	User guide reformat	BE

Functions and Features

- 2 lines x 40 characters
- Serial Interface: RS-232
- +12.0V power supply
- 1/16 duty, 1/5 bias
- RoHS Compliant

Mechanical Drawing

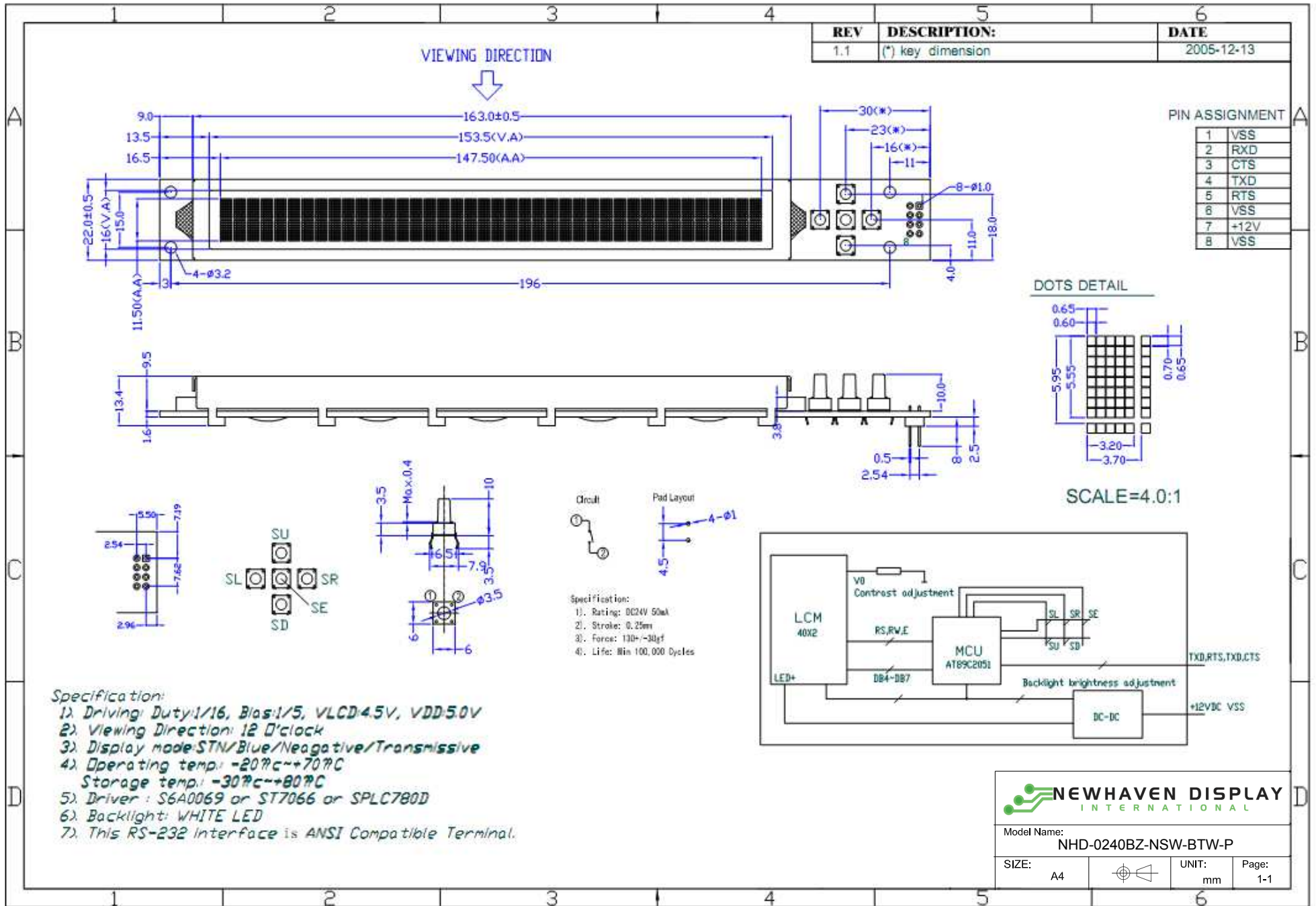

NEWHAVEN DISPLAY INTERNATIONAL

Model Name: NHD-0240BZ-NSW-BTW-P

SIZE: A4 UNIT: mm Page: 1-1

Pin Description

Pin No.	Symbol	External Connection	Function Description
1	VSS	Power Supply	Ground (0V)
2	RXT	RS-232 interface	Receive data
3	CTS	RS-232 interface	NC
4	TXD	RS-232 interface	Transfer data
5	RTS	RS-232 interface	NC
6	VSS	Power Supply	Ground (0V)
7	VDD	Power Supply	Power supply for logic (+12.0V)
8	VSS	Power Supply	Ground(0V)

LCD connector: 8-pin 2.54mm pitch standard header

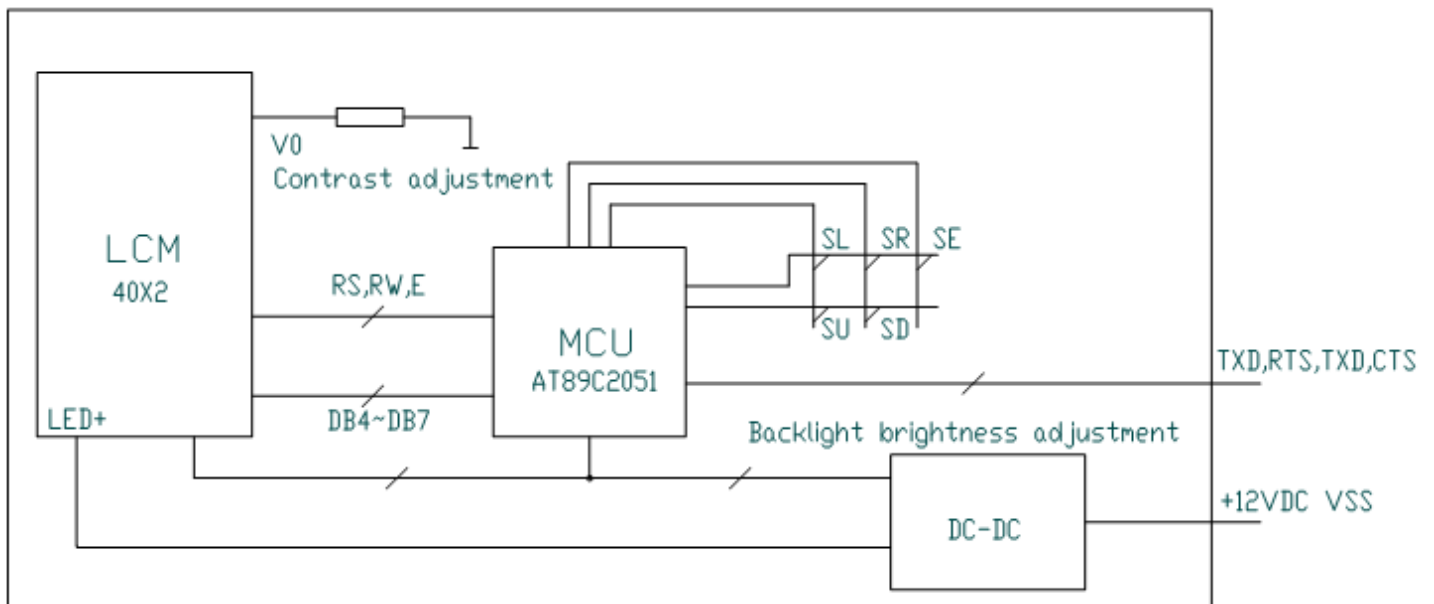

Electrical Characteristics

Item	Symbol	Condition	Min.	Typ.	Max.	Unit
Operating Temperature Range	Top		-20	-	+70	°C
Storage Temperature Range	Tst		-30	-	+80	°C
Supply Voltage	VDD		-	12.0	-	V
Supply Current	IDD	Ta=25°C VDD=12.0V	-	30	40	mA
Supply for LCD (contrast)	VDD-V0	Ta=25°C	-	4.5	-	V

Optical Characteristics

Item	Symbol	Condition	Min.	Typ.	Max.	Unit
Viewing Angle – Top		Cr ≥ 2	-	60	-	°
Viewing Angle – Bottom			-	35	-	°
Viewing Angle – Left			-	40	-	°
Viewing Angle – Right			-	40	-	°
Contrast Ratio	Cr		-	6	-	-
Response Time (rise)	Tr	-	-	150	250	ms
Response Time (fall)	Tf	-	-	150	250	ms

Protocol and Keypad function definition

This ANSI subset protocol should allow the display to be used as a limited ANSI terminal with scrolling. The display consists of 2 lines of 40 characters.

The following ANSI protocol commands shall be supported:

Backspace (BS)

Value (ASCII 8 decimal / 08 hex) Receipt of this character causes the display to move the cursor one position to the left.

Horizontal Tab (HT)

Value (ASCII 9 decimal / 09 hex) Receipt of this character causes the display to move the cursor right to the next tab stop.

Moving past the rightmost tab stop causes the cursor to move to the beginning of the following line with display scrolling up

if the cursor was on the last line. There are 4 tab stops per line at positions 4, 8, 12 and 16.

Line Feed (LF)

Value (ASCII 10 decimal / 0A hex) Receipt of this character causes the display to move the cursor down to the next line in

the same column. The display will scroll up if the cursor was on the last line.

Vertical Tab (VT)

Value (ASCII 11 decimal / 0B hex) Receipt of this character causes the display to move the cursor down to the next line in

the same column. The display will scroll up if the cursor was on the last line.

Form Feed (FF)

Value (ASCII 12 decimal / 0C hex) Receipt of this character causes the display to move the cursor down to the next line in

the same column. The display will scroll up if the cursor was on the last line.

Carriage Return (CR)

Value (ASCII 13 decimal / 0D hex) Receipt of this character causes the display to move the cursor left to the first column on

the current line. There is a User Configuration setting that will automatically add receipt of a Line Feed (LF) character after a

carriage return if required.

Cancel (CAN)

Value (ASCII 24 decimal / 18 hex) Receipt of this character causes the display to abort any escape sequence that may be in

process. No other action is taken.

Displayed Characters

Values (ASCII 32 decimal / 20 hex through ASCII 127 decimal / 7F hex) Receipt of these characters cause the display to show the character on the screen at the current cursor location, and then move the cursor right to the next position. There is a User Configuration setting that will automatically wrap the cursor to the beginning of the next line, if required, scrolling up if the cursor was on the last line. The following characters are displayed:

Lower Bits	Upper Bits					
	0010	0011	0100	0101	0110	0111
0000	space	0	@	P	`	p
0001	!	1	A	Q	a	q
0010	"	2	B	R	b	r
0011	#	3	C	S	c	s
100	\$	4	D	T	d	t
101	%	5	E	U	e	u
110	&	6	F	V	f	v
111	'	7	G	W	g	w
1000	(8	H	X	h	x
1001)	9	I	Y	i	y
1010	*	:	J	Z	j	z
1011	+	;	K	[k	{
1100	,	<	L	\	l	
1101	-	=	M]	m	}
1110	.	>	N	^	n	?
1111	/	?	O	_	o	?

ANSI Escape Sequences (ESC [)

Values (ASCII 33, 91 decimal / 1B, 5B hex) Receipt of this character sequence causes the display to attempt to decode one or more of the following characters as an ANSI control sequence. These sequences can have 1 or 2 parameters that are expressed as decimal numbers separated by a semicolon. The absence of a parameter in a control sequence causes it to assume a default value of zero.

What you have to do is send the "escape code" to the screen. These codes are often several characters long, but they all begin with ^[. This isn't the two characters ^ and [, but rather a representation of the ASCII code ESC (which is why these are called escape codes).

ESC has the value: ^[and should be sent before the rest of the code, which is simply an ASCII string.

As an example of how to use this information, here's how to clear the screen in C, using the VT100 escape codes:

```
#define ASCII_ESC 27

printf( "%c[2J", ESC );

or

puts( "\033[2J" );
```

Reset Display (ESC c)

Values (ASCII 33, 99 decimal / 1B, 63 hex) Receipt of this character sequence causes the display to clear, the cursor position to move to the upper left corner and the backlight to turn off.

Cursor Up n lines (ESC [n A)

Values (ASCII 33, 91, 48-57, 65 decimal / 1B, 5B, 30-39, 41 hex) Receipt of this character sequence causes the display to move the cursor up 'n' lines in the same column. The cursor will not move up past the first line in the display.

Cursor Up n lines to column 1 (ESC [n F)

Values (ASCII 33, 91, 48-57, 70 decimal / 1B, 5B, 30-39, 46 hex) Receipt of this character sequence causes the display to move the cursor up 'n' lines and to the first column. The cursor will not move up past the first line in the display.

Cursor Down n lines (ESC [n B)

Values (ASCII 33, 91, 48-57, 66 decimal / 1B, 5B, 30-39, 42 hex) Receipt of this character sequence causes the display to move the cursor down 'n' lines in the same column. The cursor will not move past the bottom line in the display and the display will not scroll up.

Cursor Down n lines to column 1 (ESC [n E)

Values (ASCII 33, 91, 48-57, 69 decimal / 1B, 5B, 30-39, 45 hex) Receipt of this character sequence causes the display to move the cursor down 'n' lines and to the first column. The cursor will not move past the bottom line in the display and the display will not scroll up.

Cursor Right n characters (ESC [n C)

Values (ASCII 33, 91, 48-57, 67 decimal / 1B, 5B, 30-39, 43 hex) Receipt of this character sequence causes the display to move the cursor right 'n' characters on the same line. The cursor will not move past the end of the current line.

Cursor Left n characters (ESC [n D)

Values (ASCII 33, 91, 48-57, 68 decimal / 1B, 5B, 30-39, 44 hex) Receipt of this character sequence causes the display to move the cursor left 'n' characters on the same line. The cursor will not move past the beginning of the current line.

Move cursor to n (ESC [n G)

Values (ASCII 33, 91, 48-57, 71 decimal / 1B, 5B, 30-39, 47 hex) Receipt of this character sequence causes the display to move the cursor to column 'n' on the current line. The cursor will not move past the beginning or end of the current line.

Move cursor to r, c (ESC [r ; c H)

Values (ASCII 33, 91, [[48-57], 59, [48-57]], 72 decimal / 1B, 5B, [[30-39], 3B, [30-39]], 48 hex) Receipt of this character sequence causes the display to move the cursor to row 'r', column 'c'. The value for 'r' ranges from 0 – 7, the value for 'c' ranges from 0 – 20.

Erase all or part of display (ESC [n J)

Values (ASCII 33, 91, 48-50, 74 decimal / 1B, 5B, 30-32, 4A hex) Receipt of this character sequence causes part or all of the display to clear. If 'n' = 0, the display is cleared from the cursor position to the end. If 'n' = 1, the display is cleared from the beginning to the cursor position. If 'n' = 2 the entire display is cleared, and the cursor is moved to the upper left (0, 0).

For example:

Description	ESC Code
Clear screen from cursor down	^[[J
Clear screen from cursor down	^[[OJ
Clear screen from cursor up	^[[1J
Clear entire screen	^[[2J

Erase all or part of line (ESC [n K)

Values (ASCII 33, 91, 48-50, 75 decimal / 1B, 5B, 30-32, 4B hex) Receipt of this character sequence causes part or all of the line that the cursor is on to clear. If 'n' = 0, the line is cleared from the cursor position to the end of the line. If 'n' = 1, the line is cleared from the beginning to the cursor position. If 'n' = 2 the entire line is cleared. The position of the cursor is not affected by this command.

For example:

Description	ESC Code
Clear line from cursor right	^[[K
Clear line from cursor right	^[[OK
Clear line from cursor left	^[[1K
Clear entire line	^[[2K

Save cursor position (ESC [n s)

Values (ASCII 33, 91, 114 decimal / 1B, 5B, 73 hex) Receipt of this character sequence causes the display to save the current cursor position.

Restore cursor position (ESC [n u)

Values (ASCII 33, 91, 116 decimal / 1B, 5B, 75 hex) Receipt of this character sequence causes the display to restore the previously saved cursor position.

Enter alternate keypad mode (ESC =)

Allows the keypad to enter into alternate mode

Enter alternate keypad mode (ESC >)

Exits the keypad from alternate mode

Keypad Codes

These are sent from the LCD display back to the computer when the particular key is pressed. Note that the codes sent in the alternate mode are different codes than in the default mode. See escape codes above to change keypad mode.

Keypad Key	Default mode (reset)	Alternate (set)
UP (SU in drawing)	ESC A (^[A)	ESC OA (^[OA)
DOWN (SD in drawing)	ESC B (^[B)	ESC OB (^[OB)
RIGHT (SR in drawing)	ESC C (^[C)	ESC OC (^[OC)
LEFT (SL in drawing)	ESC D (^[D)	ESC OD (^[OD)
ENTER (SE in drawing)	^M	ESC OM (^[OM)

Example Initialization Program

See program code at http://www.newhavendisplay.com/app_notes/Serial_LCD.txt

Quality Information

Test Item	Content of Test	Test Condition	Note
High Temperature storage	Endurance test applying the high storage temperature for a long time.	+80°C , 48hrs	2
Low Temperature storage	Endurance test applying the low storage temperature for a long time.	-30°C , 48hrs	1,2
High Temperature Operation	Endurance test applying the electric stress (voltage & current) and the high thermal stress for a long time.	+70°C 48hrs	2
Low Temperature Operation	Endurance test applying the electric stress (voltage & current) and the low thermal stress for a long time.	-20°C , 48hrs	1,2
High Temperature / Humidity Operation	Endurance test applying the electric stress (voltage & current) and the high thermal with high humidity stress for a long time.	+40°C , 90% RH , 48hrs	1,2
Thermal Shock resistance	Endurance test applying the electric stress (voltage & current) during a cycle of low and high thermal stress.	0°C,30min -> +25°C,5min -> +50°C,30min = 1 cycle 10 cycles	
Vibration test	Endurance test applying vibration to simulate transportation and use.	10-55Hz , 15mm amplitude. 60 sec in each of 3 directions X,Y,Z For 15 minutes	3
Static electricity test	Endurance test applying electric static discharge.	VS=800V, RS=1.5kΩ, CS=100pF One time	

Note 1: No condensation to be observed.

Note 2: Conducted after 4 hours of storage at 25°C, 0%RH.

Note 3: Test performed on product itself, not inside a container.

Precautions for using LCDs/LCMs

See Precautions at www.newhavendisplay.com/specs/precautions.pdf

Warranty Information and Terms & Conditions

http://www.newhavendisplay.com/index.php?main_page=terms