



Chipsmall Limited consists of a professional team with an average of over 10 year of expertise in the distribution of electronic components. Based in Hongkong, we have already established firm and mutual-benefit business relationships with customers from,Europe,America and south Asia,supplying obsolete and hard-to-find components to meet their specific needs.

With the principle of “Quality Parts,Customers Priority,Honest Operation,and Considerate Service”,our business mainly focus on the distribution of electronic components. Line cards we deal with include Microchip,ALPS,ROHM,Xilinx,Pulse,ON,Everlight and Freescale. Main products comprise IC,Modules,Potentiometer,IC Socket,Relay,Connector.Our parts cover such applications as commercial,industrial, and automotives areas.

We are looking forward to setting up business relationship with you and hope to provide you with the best service and solution. Let us make a better world for our industry!



## Contact us

Tel: +86-755-8981 8866 Fax: +86-755-8427 6832

Email & Skype: info@chipsmall.com Web: www.chipsmall.com

Address: A1208, Overseas Decoration Building, #122 Zhenhua RD., Futian, Shenzhen, China



# NHD-0420Z-RN-GBW

## Character Liquid Crystal Display Module

NHD- Newhaven Display  
0420- 4 lines x 20 characters  
Z- Model  
R- Reflective  
N- No Backlight  
G- STN- Gray  
B- 6:00 view  
W- Wide Temperature (-20°C ~ +70°C)  
**RoHS Compliant**

**Newhaven Display International, Inc.**

2511 Technology Drive, Suite 101

Elgin IL, 60124

Ph: 847-844-8795

Fax: 847-844-8796

[www.newhavendisplay.com](http://www.newhavendisplay.com)

[nhtech@newhavendisplay.com](mailto:nhtech@newhavendisplay.com)

[nhsales@newhavendisplay.com](mailto:nhsales@newhavendisplay.com)

## Document Revision History

Revision	Date	Description	Changed by
0	10/21/2008	Initial Release	-
1	1/27/2010	User Guide Reformat	MC
2	6/25/2010	Mechanical drawing updated	MP
3	5/23/2011	Electrical characteristics updated	AK
4	9/22/2011	Display interface and DDRAM address updated	AK

## Functions and Features

- 4 lines x 20 characters
- Built-in controllers (RW1067)
- +5.0V Power Supply
- 1/32 duty, 1/6 bias
- RoHS compliant

# Mechanical Drawing

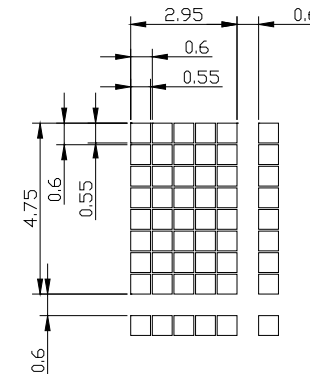
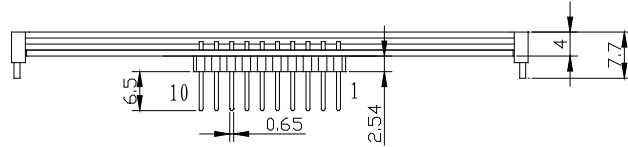
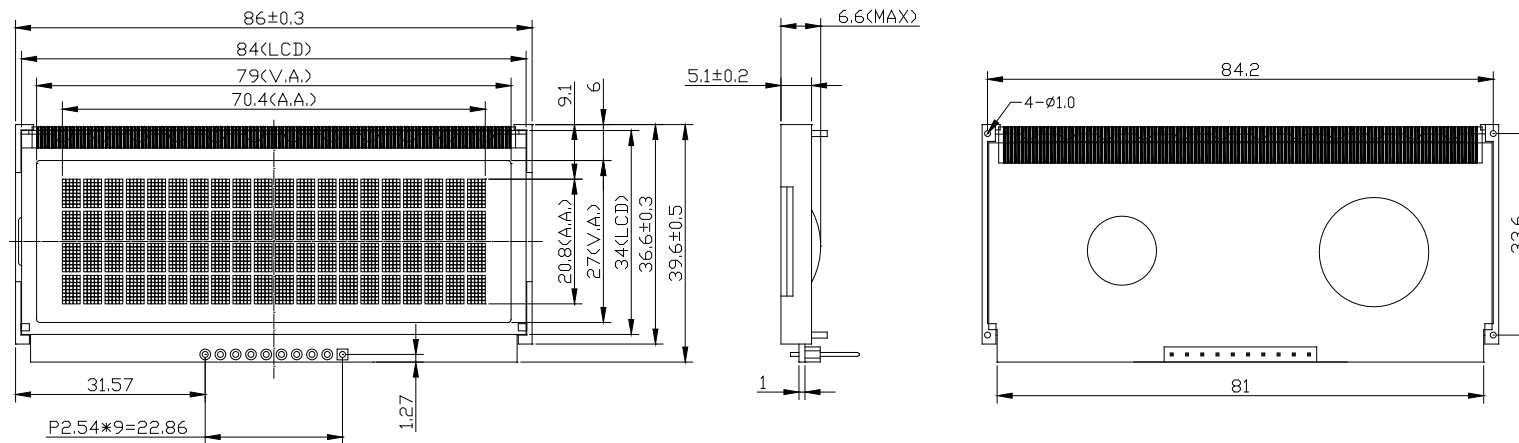

Pin connections

Pin NO	Symbol
1	VSS
2	VDD
3	V0
4	RS
5	R/W
6	E
7	DB4
8	DB5
9	DB6
10	DB7

## Specification:

- 1). Driving: Duty:1/32, Bias:1/6, VLCD:6.8V, VDD:5.0V
- 2). Viewing Direction: 6 O'clock
- 3). Display mode: STN/Gray/Positive/Reflective
- 4). Operating temp.: -20°C~+70°C  
Storage temp.: -30°C~+80°C
- 5). Driver : RW1067 4Bit MPU or 4Lines SPI
- 6). RoHS Compliant

NEWHAVEN DISPLAY

NHD-0420Z-RN-GBW

# Pin Description and Wiring Diagram

## Parallel Interface:

Pin No.	Symbol	External Connection	Function Description
1	Vss	Power Supply	Ground
2	VDD	Power Supply	Supply voltage for logic (+5.0V)
3	V0	Power Supply	Power supply for contrast (approx. -1.8V)
4	RS	MPU	Register select signal. RS=0: Command, RS=1: Data
5	R/W	MPU	Read/Write select signal, R/W=1: Read R/W:=0: Write
6	E	MPU	Operation enable signal. Falling edge triggered.
7-10	DB4-DB7	MPU	Four high order bi-directional three-state data bus lines.

## Serial Interface (default):

Pin No.	Symbol	External Connection	Function Description
1	Vss	Power Supply	Ground
2	VDD	Power Supply	Supply voltage for logic (+5.0V)
3	V0	Power Supply	Power supply for contrast (approx. -1.8V)
4	NC	-	No Connect
5	NC	-	No Connect
6	NC	-	No Connect
7	NC	-	No Connect
8	DB5/CS	MPU	Chip Select signal
9	DB6/SCL	MPU	Serial Clock signal
10	DB7/SDA	MPU	Serial Data signal

## Jumper Selections:



Recommended LCD connector: 2.54mm pitch pins

Backlight connector: --- Mates with: ---

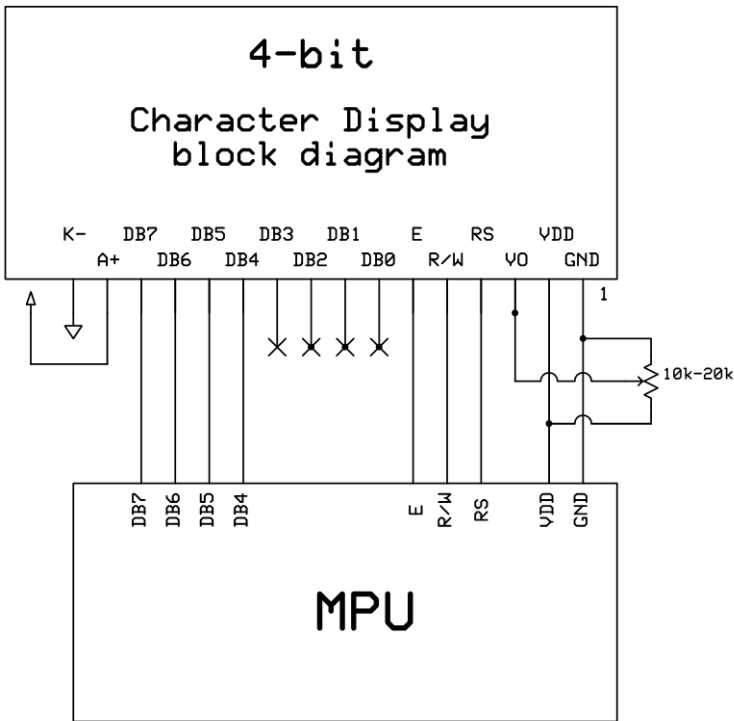

## Electrical Characteristics

Item	Symbol	Condition	Min.	Typ.	Max.	Unit
Operating Temperature Range	Top	Absolute Max	-20	-	+70	°C
Storage Temperature Range	Tst	Absolute Max	-30	-	+80	°C
Supply Voltage	VDD		4.7	5.0	5.5	V
Supply Current	IDD	Ta=25°C, VDD=5.0V	-	2	2.5	mA
Supply for LCD (contrast)	VDD-V0	Ta=25°C	-	6.8	-	V
"H" Level input	Vih		2.5	-	VDD	V
"L" Level input	Vil		0	-	0.6	V
"H" Level output	Voh		3.9	-	-	V
"L" Level output	Vol		-	-	0.4	V
Backlight Supply Voltage	Vled	-	-	-	-	V
Backlight Supply Current	Iled	-	-	-	-	mA

## Optical Characteristics

Item	Symbol	Condition	Min.	Typ.	Max.	Unit
Viewing Angle – Vertical (top)	AV	Cr ≥ 2	-	25	-	°
Viewing Angle – Vertical (bottom)	AV	Cr ≥ 2	-	70	-	°
Viewing Angle – Horizontal (left)	AH	Cr ≥ 2	-	30	-	°
Viewing Angle – Horizontal (right)	AH	Cr ≥ 2	-	30	-	°
Contrast Ratio	Cr		-	2	-	-
Response Time (rise)	Tr	-	-	120	150	ms
Response Time (fall)	Tf	-	-	120	150	ms

## Controller Information

Built-in RW1067. Download specification at [http://www.newhavendisplay.com/app\\_notes/RW1067.pdf](http://www.newhavendisplay.com/app_notes/RW1067.pdf)

## Table of Commands

Instruction	RE	Instruction Code										Description	Execution Time (fosc = 270 kHz)	
		RS	R/W	DB7	DB6	DB5	DB4	DB3	DB2	DB1	DB0			
Clear Display	x	0	0	0	0	0	0	0	0	0	0	1	Write "20H" to DDRAM, and set DDRAM address to "00H" from AC.	1.53ms
Return Home	0	0	0	0	0	0	0	0	0	0	1	X	Set DDRAM address to "00H" from AC and return cursor to its original position if shifted. The contents of DDRAM are not changed.	1.53ms
Power Down Mode	1	0	0	0	0	0	0	0	0	0	1	PD	Set power down mode bit. PD = "1": power down mode set, PD = "0": power down mode disable.	37μs
Entry Mode Set	0	0	0	0	0	0	0	0	0	1	I/D	S	Assign cursor moving direction. I/D = "1": increment I/D = "0": decrement And display shift enable bit. S = "1": make display shift of the enabled lines by the DS4 - DS1 bits in the Shift Enable instruction. S = "0": display shift disable	37μs
	1	0	0	0	0	0	0	0	0	1	1	BID	Segment bi-direction function. BID = "1": Seg80→Seg1 BID = "0": Seg1→Seg80	
Display ON/OFF Control	0	0	0	0	0	0	0	0	1	D	C	B	Set display / cursor / blink on/off D = "1": display on, D = "0": display off, C = "1": cursor on, C = "0": cursor off, B = "1": blink on, B = "0": blink off.	37μs
Extended Function set	1	0	0	0	0	0	0	0	1	0	B/W	NW	Assign black/white inverting of cursor, and 4-line display mode control bit. B/W = "1": black/white inverting of cursor enable, B/W = "0": black/white inverting of cursor disable NW = "1": 4-line display mode, NW = "0": 2-line display mode.	37μs

Instruction	RE	Instruction Code										Description	Execution Time ( fosc = 270 kHz )
		RS	R/W	DB7	DB6	DB5	DB4	DB3	DB2	DB1	DB0		
Cursor or Display shift	0	0	0	0	0	0	1	S/C	R/L	X	X	Cursor or display shift. S/C = "1" : display shift, S/C = "0" : cursor shift, R/L = "1" : shift to right, R/L = "0" : shift to left.	37µs
Shift Enable	1	0	0	0	0	0	1	DS4	DS3	DS2	DS1	(when DC = "1" ) Determine the line for display shift. DS1 = "1/0": 1st line display shift enable/disable DS2 = "1/0": 2nd line display shift enable/disable DS3 = "1/0": 3rd line display shift enable/disable DS4 = "1/0": 4th line display shift enable/disable.	37µs
Code Bank Selection	1	0	0	0	0	0	1	X	X	CB1	CB0	(when DC = "0" ) CB1, CB0 = ( 0, 0 ) ROM code Bank 0 selected ( 0, 1 ) ROM code Bank 1 selected ( 1, 0 ) ROM code Bank 2 selected ( 1, 1 ) ROM code Bank 3 selected	37µs
Function Set	0	0	0	0	0	1	IF	X	RE(0)	DC	REV	Set interface data length (IF = "1": 8-bit, IF = "0": 4-bit ), extension register, RE("0"), shift enable. DC = "1": enable display shift per line. DC = "0": enable the selection of code bank. Reverse bit REV = "1": reverse display, REV = "0": normal display.	37µs
	1	0	0	0	0	1	IF	X	RE(1)	BE	0	Set IF, N, RE("1") and CGRAM/SEGRAM blink enable (BE) BE = "1/0": CGRAM/SEGRAM blink enable/disable.	37µs



Instruction	RE	Instruction Code										Description	Execution Time ( fosc = 270 kHz )
		RS	R/W	DB7	DB6	DB5	DB4	DB3	DB2	DB1	DB0		
Set CGRAM Address	0	0	0	0	1	AC5	AC4	AC3	AC2	AC1	AC0	Set CGRAM address in address counter.	37μs
Set SEGRAM Address	1	0	0	0	1	X	X	AC3	AC2	AC1	AC0	Set SEGRAM address in address counter	37μs
Set DDRAM Address	0	0	0	1	AC6	AC5	AC4	AC3	AC2	AC1	AC0	Set DDRAM address in address counter	37μs
Set Data Length	1	0	0	1	SD6	SD5	SD4	SD3	SD2	SD1	SD0	Set data length for 3 line SPI	37μs
Read Busy flag and Address	X	0	1	BF	AC6	AC5	AC4	AC3	AC2	AC1	AC0	Can know internal operation is ready or not by reading BF. The contents of address counter can also be read. BF = "1": busy state, BF = "0": ready state.	0μs
Write Data	X	1	0	D7	D6	D5	D4	D3	D2	D1	D0	Write data into internal RAM. (DDRAM / CGRAM / SEGRAM).	43μs
Read Data	X	1	1	D7	D6	D5	D4	D3	D2	D1	D0	Read data from internal RAM. (DDRAM / CGRAM / SEGRAM).	43μs

- Note : 1. When an MPU program with Busy Flag(DB7) checking is made, 1/2 FOSC ( is necessary ) for executing the next instruction by the " E " signal after the Busy Flag ( DB7) goes to " Low ".  
2. " X " Don't care

## Display Character Address Code

	1	2	3	4	5	6	7	8	9	10	11	12	13	14	15	16	← Display Position
COM1 COM8	00	01	02	03	04	05	06	07	08	09	0A	0B	0C	0D	0E	0F	← DDRAM Address
COM9 COM16	20	21	22	23	24	25	26	27	29	29	2A	2B	2C	2D	2E	2F	
COM17 COM24	40	41	42	43	44	45	46	47	48	49	4A	4B	4C	4D	4E	4F	
COM25 COM32	60	61	62	63	64	65	66	67	68	69	6A	6B	6C	6D	6E	6F	
	SEG1					RW1067						SEG80					

## Timing Characteristics

<i>Write Mode (Writing data from MPU to RW1067)</i>						
$t_C$	Enable Cycle Time	Pin E (except clear display)	80	-	-	ns
$t_{PW}$	Enable Pulse Width	Pin E	40	-	-	ns
$t_{R,t_F}$	Enable Rise/Fall Time	Pin E	-	-	25	ns
$t_{AS}$	Address Setup Time	Pins: RS,RW,E	0	-	-	ns
$t_{AH}$	Address Hold Time	Pins: RS,RW,E	10	-	-	ns
$t_{DSW}$	Data Setup Time	Pins: DB0 - DB7	20	-	-	ns
$t_H$	Data Hold Time	Pins: DB0 - DB7	10	-	-	ns

- Writing data from MPU to RW1067(serial)

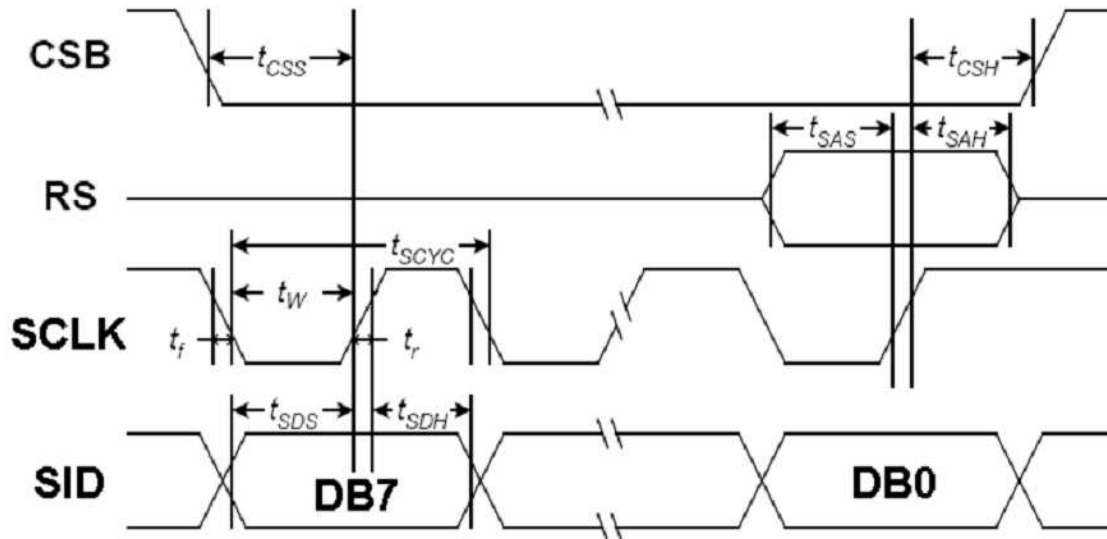

<i>Read Mode (Reading Data from RW1067 to MPU)</i>						
$t_C$	Enable Cycle Time	Pin E	1200	-	-	ns
$t_{PW}$	Enable Pulse Width	Pin E	480	-	-	ns
$t_R, t_F$	Enable Rise/Fall Time	Pin E	-	-	25	ns
$t_{AS}$	Address Setup Time	Pins: RS,RW,E	0	-	-	ns
$t_{AH}$	Address Hold Time	Pins: RS,RW,E	10	-	-	ns
$t_{DDR}$	Data Setup Time	Pins: DB0 - DB7	-	-	320	ns
$t_H$	Data Hold Time	Pins: DB0 - DB7	10	-	-	ns

- Reading data from RW1067 to MPU(parallel)

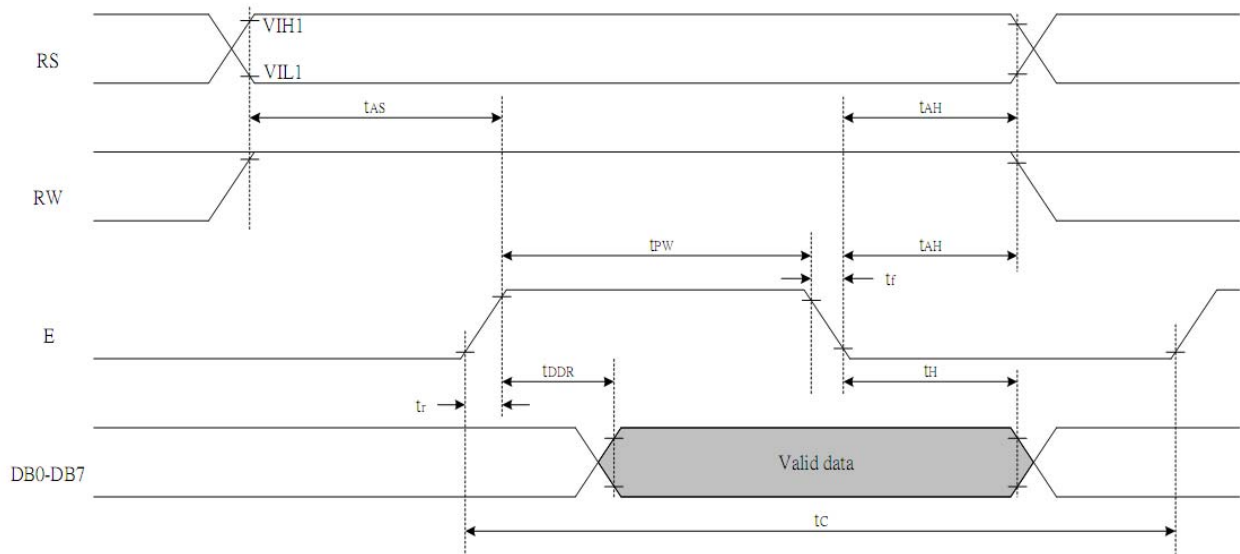

# Built-in Font Table

Lower 4 Bits \ Upper 4 Bits	0000	0001	0010	0011	0100	0101	0110	0111	1000	1001	1010	1011	1100	1101	1110	1111
xxxx0000	CG RAM (1)			0	a	P	`	P				-	夕	三	α	ρ
xxxx0001	(2)		!	1	A	Q	a	q			。	ア	チ	△	ä	q
xxxx0010	(3)		"	2	B	R	b	r			「	イ	ツ	×	ρ	θ
xxxx0011	(4)		#	3	C	S	c	s			」	ウ	テ	モ	ε	ε
xxxx0100	(5)		\$	4	D	T	d	t			、	エ	ト	ト	μ	Ω
xxxx0101	(6)		%	5	E	U	e	u			・	オ	ナ	1	ε	Ω
xxxx0110	(7)		&	6	F	V	f	v			ヲ	カ	ニ	ヨ	ρ	Σ
xxxx0111	(8)		'	7	G	W	g	w			ヲ	キ	ヌ	ラ	g	π
xxxx1000	(1)		<	8	H	X	h	x			イ	ク	ネ	リ	γ	Σ
xxxx1001	(2)		>	9	I	Y	i	y			ウ	ケ	ル	ル	γ	γ
xxxx1010	(3)		*	:	J	Z	j	z			エ	コ	ハ	レ	j	≠
xxxx1011	(4)		+	:	K	[	k	[			オ	サ	ヒ	ロ	*	≠
xxxx1100	(5)		,	<	L	¥	l	l			カ	シ	フ	ワ	φ	≠
xxxx1101	(6)		-	=	M	]	m	]			ユ	ス	ハ	ン	も	÷
xxxx1110	(7)		.	>	N	^	n	→			ヨ	セ	ホ	°	ら	
xxxx1111	(8)		/	?	O	_	o	←			ッ	ソ	マ	°	ö	■

## Example Initialization Program

4-bit Initialization:

```

/*****/
void command(char i)
{
    P1 = i;                //put data on output Port
    D_I = 0;              //D/I=LOW : send instruction
    R_W = 0;              //R/W=LOW : Write
    Nybble();             //Send lower 4 bits
    i = i<<4;             //Shift over by 4 bits
    P1 = i;                //put data on output Port
    Nybble();             //Send upper 4 bits
}
/*****/
void write(char i)
{
    P1 = i;                //put data on output Port
    D_I = 1;              //D/I=HIGH : send data
    R_W = 0;              //R/W=LOW : Write
    Nybble();             //Clock lower 4 bits
    i = i<<4;             //Shift over by 4 bits
    P1 = i;                //put data on output Port
    Nybble();             //Clock upper 4 bits
}
/*****/
void Nybble()
{
    E = 1;
    Delay(1);              //enable pulse width >= 300ns
    E = 0;                //Clock enable: falling edge
}
/*****/
void init()
{
    P1 = 0;
    P3 = 0;
    Delay(100);           //Wait >15 msec after power is applied
    P1 = 0x30;           //put 0x30 on the output port
    Delay(30);           //must wait 5ms, busy flag not available
    Nybble();            //command 0x30 = Wake up
    Delay(10);           //must wait 160us, busy flag not available
    Nybble();            //command 0x30 = Wake up #2
    Delay(10);           //must wait 160us, busy flag not available
    Nybble();            //command 0x30 = Wake up #3
    Delay(10);           //can check busy flag now instead of delay
    P1= 0x20;            //put 0x20 on the output port
    Nybble();            //Function set: 4-bit interface
    command(0x28);       //Function set: 4-bit/2-line
    command(0x10);       //Set cursor
    command(0x0F);       //Display ON; Blinking cursor
    command(0x06);       //Entry Mode set
}
/*****/
```

## Quality Information

Test Item	Content of Test	Test Condition	Note
High Temperature storage	Endurance test applying the high storage temperature for a long time.	+80°C , 48hrs	2
Low Temperature storage	Endurance test applying the low storage temperature for a long time.	-30°C , 48hrs	1,2
High Temperature Operation	Endurance test applying the electric stress (voltage & current) and the high thermal stress for a long time.	+70°C 48hrs	2
Low Temperature Operation	Endurance test applying the electric stress (voltage & current) and the low thermal stress for a long time.	-20°C , 48hrs	1,2
High Temperature / Humidity Operation	Endurance test applying the electric stress (voltage & current) and the high thermal with high humidity stress for a long time.	+40°C , 90% RH , 48hrs	1,2
Thermal Shock resistance	Endurance test applying the electric stress (voltage & current) during a cycle of low and high thermal stress.	0°C,30min -> 25°C,5min -> 50°C,30min = 1 cycle 10 cycles	
Vibration test	Endurance test applying vibration to simulate transportation and use.	10-55Hz , 15mm amplitude. 60 sec in each of 3 directions X,Y,Z For 15 minutes	3
Static electricity test	Endurance test applying electric static discharge.	VS=800V, RS=1.5kΩ, CS=100pF One time	

**Note 1:** No condensation to be observed.

**Note 2:** Conducted after 4 hours of storage at 25°C, 0%RH.

**Note 3:** Test performed on product itself, not inside a container.

## Precautions for using LCDs/LCMs

See Precautions at [www.newhavendisplay.com/specs/precautions.pdf](http://www.newhavendisplay.com/specs/precautions.pdf)

## Warranty Information and Terms & Conditions

[http://www.newhavendisplay.com/index.php?main\\_page=terms](http://www.newhavendisplay.com/index.php?main_page=terms)