



Chipsmall Limited consists of a professional team with an average of over 10 year of expertise in the distribution of electronic components. Based in Hongkong, we have already established firm and mutual-benefit business relationships with customers from,Europe,America and south Asia,supplying obsolete and hard-to-find components to meet their specific needs.

With the principle of “Quality Parts,Customers Priority,Honest Operation,and Considerate Service”,our business mainly focus on the distribution of electronic components. Line cards we deal with include Microchip,ALPS,ROHM,Xilinx,Pulse,ON,Everlight and Freescale. Main products comprise IC,Modules,Potentiometer,IC Socket,Relay,Connector.Our parts cover such applications as commercial,industrial, and automotives areas.

We are looking forward to setting up business relationship with you and hope to provide you with the best service and solution. Let us make a better world for our industry!



Contact us

Tel: +86-755-8981 8866 Fax: +86-755-8427 6832

Email & Skype: info@chipsmall.com Web: www.chipsmall.com

Address: A1208, Overseas Decoration Building, #122 Zhenhua RD., Futian, Shenzhen, China



NHD-0440AZ-NLY-FBW-C6

Character Liquid Crystal Display Module

NHD-	Newhaven Display
0440-	4 lines x 40 characters
AZ-	Model
N-	Transmissive
LY-	Lower Yellow/Green LED Backlight
F-	FSTN (-)
B-	6:00 view
W-	Wide Temp. (-20°C~+70°C)
C-	2x8 Pin FCI part # 88874-016, shrouded header, 30u gold, right-angle, lead free, 5.84mm mating length. Header soldered onto component side of LCD PCB.
6-	R6= 3.3k ohm resistor

RoHS Compliant

Newhaven Display International, Inc.

2511 Technology Drive, Suite 101

Elgin IL, 60124

Ph: 847-844-8795

Fax: 847-844-8796

www.newhavendisplay.com

nhtech@newhavendisplay.com

nhsales@newhavendisplay.com

Document Revision History

Revision	Date	Description	Changed by
0	10/21/2008	Initial Release	-
1	10/29/2009	User Guide Reformat	MC
2	11/17/2009	Updated Block diagram and initialization code	MC
3	12/16/2009	Updated Backlight Supply Voltage and Current	MC

Functions and Features

- 4 lines x 40 characters
- 2 Built-in controllers (SPLC780D or equivalent)
- +5.0V Power Supply
- 1/16 duty, 1/5 bias
- RoHS compliant

Pin Description and Wiring Diagram

Pin No.	Symbol	External Connection	Function Description
1-4	DB7-DB4	MPU	Four high order bi-directional three-state data bus lines.
5-8	DB3-DB0	MPU	Four low order bi-directional three-state data bus lines. These four are not used during 4-bit operation.
9	E1	MPU	Operation enable signal. Falling edge triggered for top 2 lines.
10	R/W	MPU	Read/Write select signal, R/W=1: Read R/W:=0: Write
11	RS	MPU	Register select signal. RS=0: Command, RS=1: Data
12	V0	Power Supply	Power supply for contrast (approx. 0V)
13	Vss	Power Supply	Ground
14	VDD	Power Supply	Supply voltage for logic (+5.0V)
15	E2	MPU	Operation enable signal. Falling edge triggered for bottom 2 lines.
16	NC	-	No Connect
17	LED+	Power Supply	Power supply for LED backlight (+5.0V via on-board resistor)
18	LED-	Power Supply	Ground for backlight

Recommended LCD connector: 2.54mm pitch pins

Backlight connector: --- **Mates with:** ---

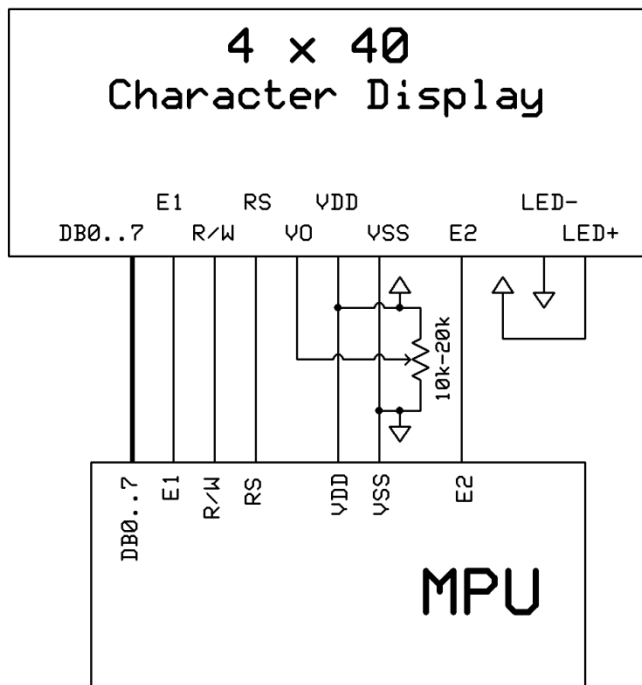

Electrical Characteristics

Item	Symbol	Condition	Min.	Typ.	Max.	Unit
Operating Temperature Range	Top	Absolute Max	-20	-	+70	°C
Storage Temperature Range	Tst	Absolute Max	-30	-	+80	°C
Supply Voltage	VDD		2.7	5.0	5.5	V
Supply Current	IDD	Ta=25°C, VDD=5.0V	-	3.5	4.0	mA
Supply for LCD (contrast)	VDD-V0	Ta=25°C	-	5.0	-	V
"H" Level input	Vih		2.2	-	VDD	V
"L" Level input	Vil		0	-	0.6	V
"H" Level output	Voh		2.4	-	-	V
"L" Level output	Vol		-	-	0.4	V
Backlight Supply Voltage	Vled	-	-	5.0	5.0	V
Backlight Supply Current	Iled	Vled=5.0V	-	360	480	mA

Optical Characteristics

Item	Symbol	Condition	Min.	Typ.	Max.	Unit
Viewing Angle – Vertical (top)	AV	Cr ≥ 3	-	20	-	°
Viewing Angle – Vertical (bottom)	AV	Cr ≥ 3	-	50	-	°
Viewing Angle – Horizontal (left)	AH	Cr ≥ 3	-	30	-	°
Viewing Angle – Horizontal (right)	AH	Cr ≥ 3	-	30	-	°
Contrast Ratio	Cr		3	5	-	-
Response Time (rise)	Tr	-	-	150	250	ms
Response Time (fall)	Tf	-	-	150	250	ms

Controller Information

Built-in SPLC780D. Download specification at http://www.newhavendisplay.com/app_notes/SPLC780D.pdf

Table of Commands

Instruction	Instruction Code										Description	Execution time (fosc=270KHz)	
	RS	R/W	DB7	DB6	DB5	DB4	DB3	DB2	DB1	DB0			
Clear Display	0	0	0	0	0	0	0	0	0	1	Write "20H" to DDRAM and set DDRAM address to "00H" from AC	1.52ms	
Return Home	0	0	0	0	0	0	0	0	0	1	-	Set DDRAM address to "00H" from AC and return cursor to its original position if shifted. The contents of DDRAM are not changed.	1.52ms
Entry Mode Set	0	0	0	0	0	0	0	0	1	I/D	S	Assign cursor moving direction and enable the shift of entire display	38μs
Display ON/OFF Control	0	0	0	0	0	0	0	1	D	C	B	Set display(D), cursor(C), and blinking of cursor(B) on/off control bit.	38μs
Cursor or Display Shift	0	0	0	0	0	1	S/C	R/L	-	-	-	Set cursor moving and display shift control bit, and the direction, without changing of DDRAM data.	38μs
Function Set	0	0	0	0	1	DL	N	F	-	-	-	Set interface data length (DL: 8bit/4-bit), numbers of display line (N: 2-line/1-line) and, display font type (F:5x10 dots/5x8 dots)	38μs
Set CGRAM Address	0	0	0	1	AC5	AC4	AC3	AC2	AC1	AC0	-	Set CGRAM address in address counter.	38μs
Set DDRAM Address	0	0	1	AC6	AC5	AC4	AC3	AC2	AC1	AC0	-	Set DDRAM address in counter	38μs
Read Busy Flag and Address Counter	0	1	BF	AC6	AC5	AC4	AC3	AC2	AC1	AC0	-	Whether during internal operation or not can be known by reading BF. The contents of address counter can also be read.	
Write Data to RAM	1	0	D7	D6	D5	D4	D3	D2	D1	D0	-	Write data into internal RAM (DDRAM/CGRAM).	38μs
Read Data from RAM	1	1	D7	D6	D5	D4	D3	D2	D1	D0	-	Read data from internal RAM (DDRAM/CGRAM).	38μs

Note: "-": don't care

DDRAM address:

															Display position				
1	2	3	4	5	-	-	-	-	-	-	-	-	-	-	36	37	38	39	40
00	01	02	03	04	-	-	-	-	-	-	-	-	-	-	23	24	25	26	27
40	40	41	42	43	-	-	-	-	-	-	-	-	-	-	63	64	65	66	67
00	01	02	03	04	-	-	-	-	-	-	-	-	-	-	23	24	25	26	27
40	40	41	42	43	-	-	-	-	-	-	-	-	-	-	63	64	65	66	67

DDRAM address

Timing Characteristics

Writing data from MPU to S PLC780D

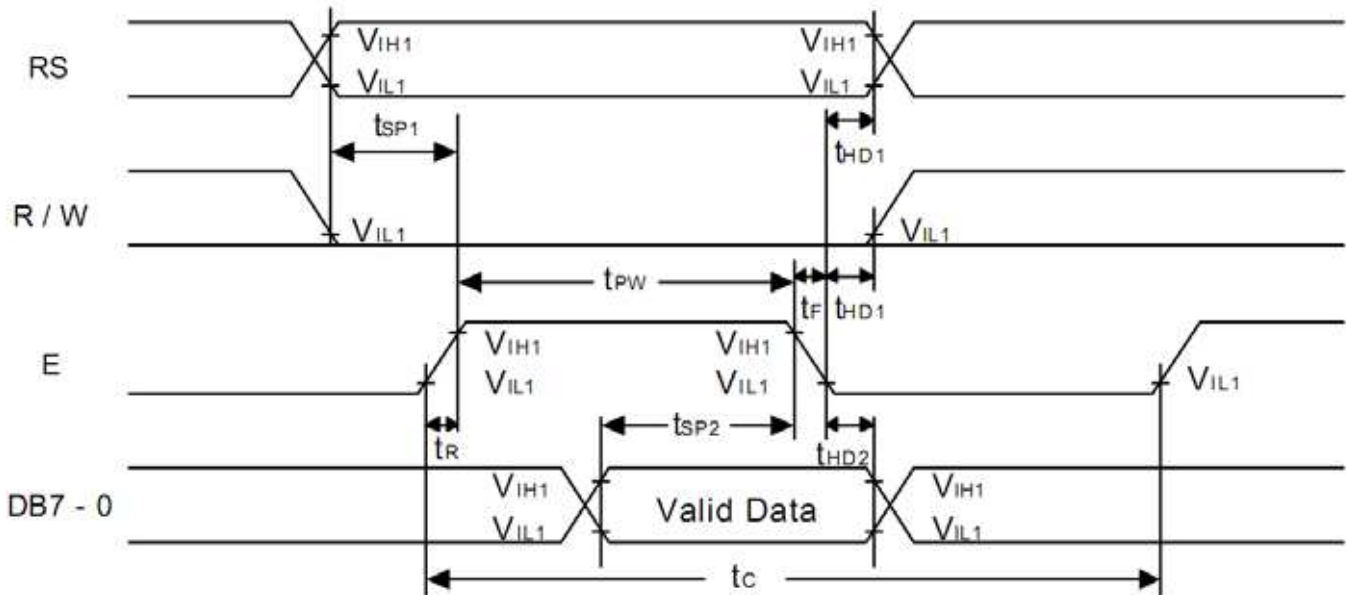

Reading data from S PLC780D to MPU

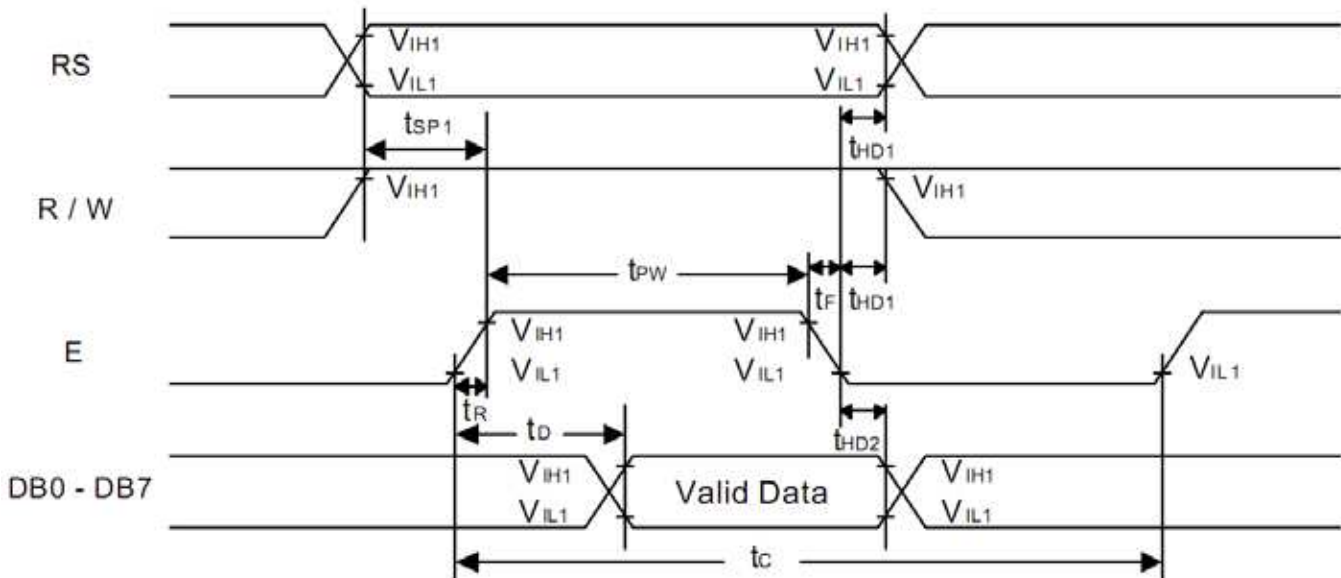

Writing Data from MPU to SPLC780D.

Characteristics	Symbol	Limit			Unit	Test Condition
		Min.	Typ.	Max.		
E Cycle Time	t_c	500	-	-	ns	Pin E
E Pulse Width	t_{PW}	230	-	-	ns	Pin E
E Rise/Fall Time	t_R, t_F	-	-	20	ns	Pin E
Address Setup Time	t_{SP1}	40	-	-	ns	Pins: RS, R/W, E
Address Hold Time	t_{HD1}	10	-	-	ns	Pins: RS, R/W, E
Data Setup Time	t_{SP2}	80	-	-	ns	Pins: DB0 - DB7
Data Hold Time	t_{HD2}	10	-	-	ns	Pins: DB0 - DB7

Reading Data from SPLC780D to MPU.

Characteristics	Symbol	Limit			Unit	Test Condition
		Min.	Typ.	Max.		
E Cycle Time	t_c	500	-	-	ns	Pin E
E Pulse Width	t_W	230	-	-	ns	Pin E
E Rise/Fall Time	t_R, t_F	-	-	20	ns	Pin E
Address Setup Time	t_{SP1}	40	-	-	ns	Pins: RS, R/W, E
Address Hold Time	t_{HD1}	10	-	-	ns	Pins: RS, R/W, E
Data Output Delay Time	t_D	-	-	120	ns	Pins: DB0 - DB7
Data hold time	t_{HD2}	5.0	-	-	ns	Pin DB0 - DB7

Built-in Font Table

Lower 4 Bits \ Upper 4 Bits	0000	0001	0010	0011	0100	0101	0110	0111	1000	1001	1010	1011	1100	1101	1110	1111
xxxx0000	CG RAM (1)			0	a	P	`	P				-	夕	ミ	α	ρ
xxxx0001	(2)		!	1	A	Q	a	q			。	ア	チ	△	ä	q
xxxx0010	(3)		"	2	B	R	b	r			「	イ	ツ	×	ρ	θ
xxxx0011	(4)		#	3	C	S	c	s			」	ウ	テ	モ	ε	ε
xxxx0100	(5)		\$	4	D	T	d	t			、	エ	ト	ト	μ	Ω
xxxx0101	(6)		%	5	E	U	e	u			・	オ	ナ	1	ε	ü
xxxx0110	(7)		&	6	F	V	f	v			ヲ	カ	ニ	ヨ	ρ	Σ
xxxx0111	(8)		'	7	G	W	g	w			ヲ	キ	ヌ	ラ	g	π
xxxx1000	(1)		<	8	H	X	h	x			イ	ク	ネ	リ	γ	Σ
xxxx1001	(2)		>	9	I	Y	i	y			ウ	ケ	ル	ル	γ	γ
xxxx1010	(3)		*	:	J	Z	j	z			エ	コ	ハ	レ	j	≠
xxxx1011	(4)		+	:	K	[k	<			オ	サ	ヒ	ロ	*	≠
xxxx1100	(5)		,	<	L	¥	l	l			カ	シ	フ	ワ	φ	≠
xxxx1101	(6)		-	=	M]	m	>			ユ	ス	ハ	ン	も	÷
xxxx1110	(7)		.	>	N	^	n	→			ヨ	セ	ホ	°	ら	
xxxx1111	(8)		/	?	O	_	o	←			ッ	ソ	マ	°	ö	■

Example Initialization Program

```
/******
```

```
void command1(char i)          //Top half of the display
```

```
{  
  
    P1 = i;  
  
    W = 0;  
  
    RS = 0;  
  
    E1 = 1;  
  
    delay(2);  
  
    E1 = 0;
```

```
}
```

```
void command2(char i)          //Bottom half of the display
```

```
{  
  
    P1 = i;  
  
    W = 0;  
  
    RS = 0;  
  
    E2 = 1;  
  
    delay(2);  
  
    E2 = 0;
```

```
}
```

```
/******
```

```
void writedata1(char i)        //Top half of the display
```

```
{  
  
    P1 = i;  
  
    W = 0;  
  
    RS = 1;  
  
    E1 = 1;  
  
    delay(2);  
  
    E1 = 0;
```

```
}
```

```
void writedata2(char i)        //Bottom half of the display
```

```
{  
  
    P1 = i;
```

```

W = 0;

RS = 1;

E2 = 1;

delay(2);

E2 = 0;

}

/*****/

void init_LCD()

{

    delay(15);

    command1(0x30);    //Wake up

    command2(0x30);

    delay(5);

    command1(0x30);    //Wake up

    command2(0x30);

    delay(5);

    command1(0x30);    //Wake up

    command2(0x30);

    delay(5);

    command1(0x38);    //Function Set = 8bit mode; 2-line; 5x8

    command2(0x38);

    command1(0x08);    //Turn off display

    command2(0x08);

    command1(0x01);    //Clear display

    command2(0x01);

    command1(0x06);    //Entry mode cursor increment

    command2(0x06);

    command1(0x0c);    //Turn on display; no cursor

    command2(0x0c);

}

/*****/

```

Quality Information

Test Item	Content of Test	Test Condition	Note
High Temperature storage	Endurance test applying the high storage temperature for a long time.	+80°C , 48hrs	2
Low Temperature storage	Endurance test applying the low storage temperature for a long time.	-30°C , 48hrs	1,2
High Temperature Operation	Endurance test applying the electric stress (voltage & current) and the high thermal stress for a long time.	+70°C 48hrs	2
Low Temperature Operation	Endurance test applying the electric stress (voltage & current) and the low thermal stress for a long time.	-20°C , 48hrs	1,2
High Temperature / Humidity Operation	Endurance test applying the electric stress (voltage & current) and the high thermal with high humidity stress for a long time.	+40°C , 90% RH , 48hrs	1,2
Thermal Shock resistance	Endurance test applying the electric stress (voltage & current) during a cycle of low and high thermal stress.	0°C,30min -> 25°C,5min -> 50°C,30min = 1 cycle 10 cycles	
Vibration test	Endurance test applying vibration to simulate transportation and use.	10-55Hz , 15mm amplitude. 60 sec in each of 3 directions X,Y,Z For 15 minutes	3
Static electricity test	Endurance test applying electric static discharge.	VS=800V, RS=1.5kΩ, CS=100pF One time	

Note 1: No condensation to be observed.

Note 2: Conducted after 4 hours of storage at 25°C, 0%RH.

Note 3: Test performed on product itself, not inside a container.

Precautions for using LCDs/LCMs

See Precautions at www.newhavendisplay.com/specs/precautions.pdf

Warranty Information and Terms & Conditions

http://www.newhavendisplay.com/index.php?main_page=terms