



Chipsmall Limited consists of a professional team with an average of over 10 year of expertise in the distribution of electronic components. Based in Hongkong, we have already established firm and mutual-benefit business relationships with customers from,Europe,America and south Asia,supplying obsolete and hard-to-find components to meet their specific needs.

With the principle of “Quality Parts,Customers Priority,Honest Operation,and Considerate Service”,our business mainly focus on the distribution of electronic components. Line cards we deal with include Microchip,ALPS,ROHM,Xilinx,Pulse,ON,Everlight and Freescale. Main products comprise IC,Modules,Potentiometer,IC Socket,Relay,Connector.Our parts cover such applications as commercial,industrial, and automotives areas.

We are looking forward to setting up business relationship with you and hope to provide you with the best service and solution. Let us make a better world for our industry!



Contact us

Tel: +86-755-8981 8866 Fax: +86-755-8427 6832

Email & Skype: info@chipsmall.com Web: www.chipsmall.com

Address: A1208, Overseas Decoration Building, #122 Zhenhua RD., Futian, Shenzhen, China



NHD-12232KZ-NSW-BBW-P

Graphic Liquid Crystal Display Module

NHD- Newhaven Display
12232- 122 x 32 pixels
KZ- Model
N- Transmissive
SW- Side White LED Backlight
B- STN- Blue (-)
B- 6:00 view
W- Wide Temp (-20°C ~ +70°C)
P- With Pin Connector
RoHS Compliant

Newhaven Display International, Inc.

2511 Technology Drive, Suite 101

Elgin IL, 60124

Ph: 847-844-8795

Fax: 847-844-8796

www.newhavendisplay.com

nhtech@newhavendisplay.com

nhsales@newhavendisplay.com

Document Revision History

Revision	Date	Description	Changed by
0	6/7/2007	Initial Release	-
1	9/25/2009	User guide reformat	BE
2	3/15/2010	Pin description, electrical, optical, drawing updated	BE
3	5/10/2010	Initialization updated	BE

Functions and Features

- 122 x 32 pixels
- Built-in SBN1661G_M02 Controller
- +5.0V power supply
- 1/32 duty cycle; 1/6 bias
- RoHS Compliant

Mechanical Drawing

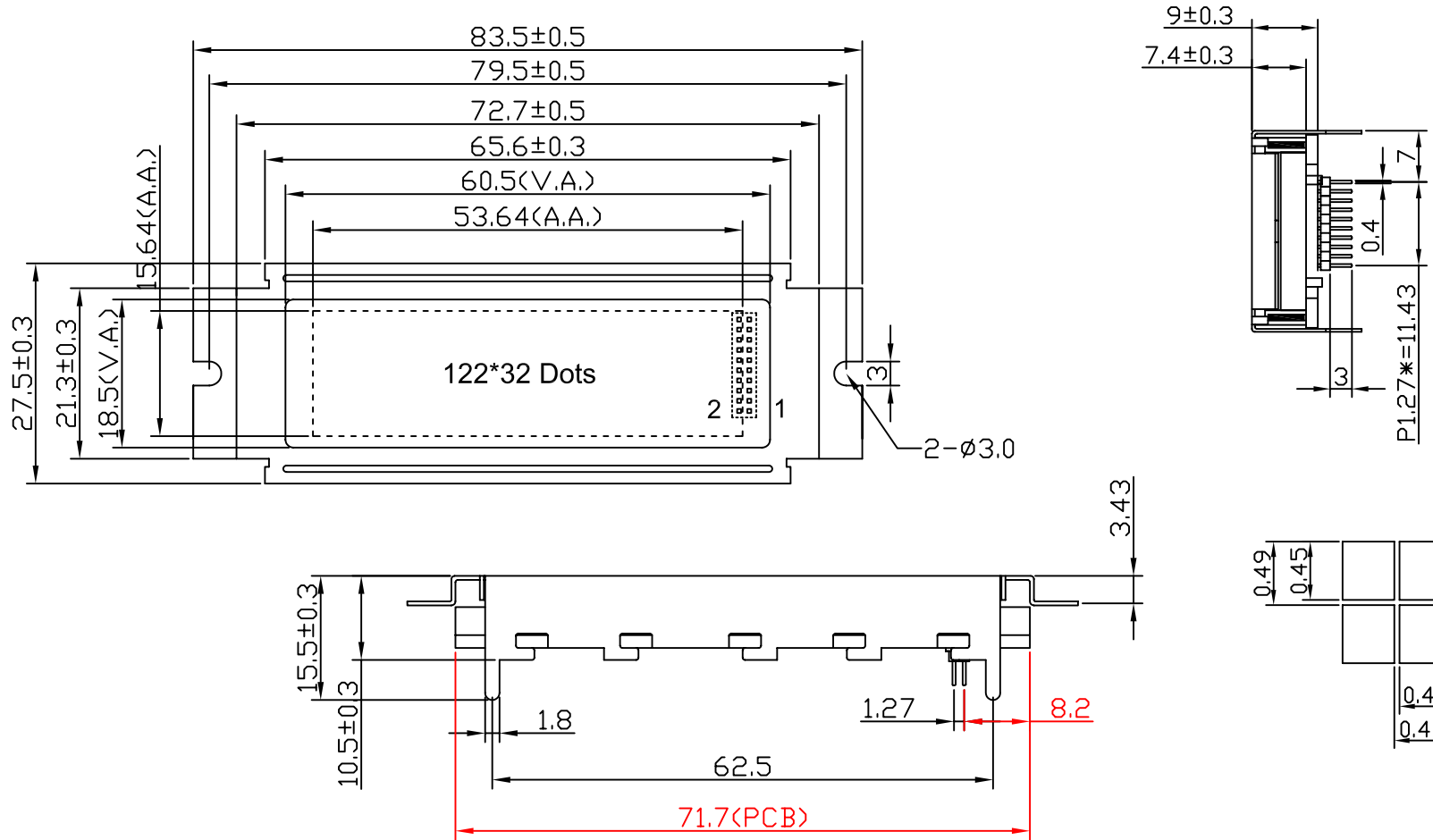

PIN ASSIGNMENT

1	A0
2	/CS2
3	/CS1
4	CL
5	E
6	/RW
7	VSS
8	DB0
9	DB1
10	DB2
11	DB3
12	DB4
13	DB5
14	DB6
15	DB7
16	VDD
17	/RES
18	V0
19	LED+
20	LED-

Specification:

- 1). Driving: Duty:1/32, Bias:1/6, VLCD:6.5V, VDD:5.0V
- 2). Viewing Direction: 6 O'clock
- 3). Display mode: STN/Blue/Negative/Transmissive
- 4). Operating temp.: $-20^{\circ}\text{C} \sim +70^{\circ}\text{C}$
Storage temp.: $-30^{\circ}\text{C} \sim +80^{\circ}\text{C}$
- 5). Driver : SBN1661G_M02
- 6). Backlight: LED Backlight/White

Model Name: NHD-12232KZ-NSW-BBW-P		NEWHAVEN DISPLAY	
GENERAL TOL: ± 0.2			
APPROVALS	DATE	DRAWN NO.	SCALE: 1:1
DWN: Qipei Qiu			
CHK:		SIZE: A4	UNIT: mm
APP: Guoxiang Ye			Page: 1-1

Pin Description and Wiring Diagram

Pin No.	Symbol	External Connection	Function Description
1	A0	MPU	Register Select. 0: instruction; 1: data
2	/CS2	MPU	Active LOW Chip Select Signal for LEFT half of LCD
3	/CS1	MPU	Active LOW Chip Select Signal for RIGHT half of LCD
4	CL	-	Clock signal; Requires 2KHz external clock.
5	E	MPU	Operation enable signal. Falling edge triggered.
6	/RW	MPU	Read/Write select signal. R/W=1: Read R/W: =0: Write
7	VSS	Power Supply	Ground
8-15	DB0-DB7	MPU	This is an 8-bit Bi-directional data bus
16	VDD	Power Supply	Power supply for logic (+5.0V)
17	/RES	MPU	Active LOW Reset signal
18	V0	Adj Power Supply	Power supply for contrast; Requires external negative voltage (approx. -1.5V)
19	LED+	Power Supply	Power supply for LED Backlight (+5.0V via on-board resistor)
20	LED-	Power Supply	Ground for Backlight

Recommended LCD connector: 1.27mm pitch pins

Backlight connector: - **Mates with:** -

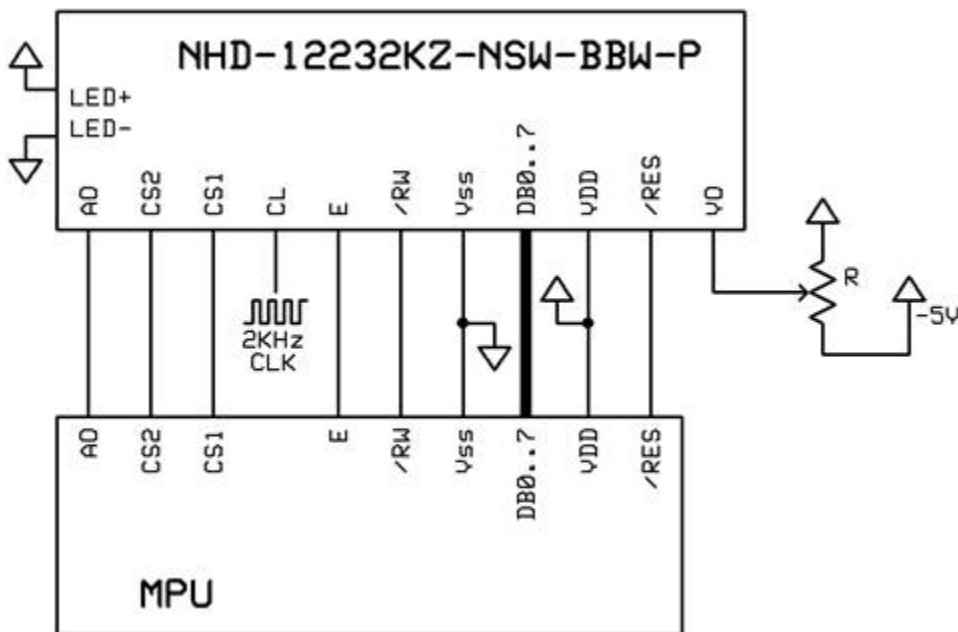

Electrical Characteristics

Item	Symbol	Condition	Min.	Typ.	Max.	Unit
Operating Temperature Range	Top	Absolute Max	-20	-	+70	°C
Storage Temperature Range	Tst	Absolute Max	-30	-	+80	°C
Supply Voltage	VDD		4.7	5.0	5.5	V
Supply Current	IDD	Ta=25°C, VDD=5.0V	-	2.0	3.0	mA
Supply for LCD (contrast)	VDD-V0	Ta=25°C	-	6.5	-	V
"H" Level input	VIH		2.2	-	VDD	V
"L" Level input	VIL	-	0	-	0.6	V
"H" Level output	VOH	-	2.4	-	-	V
"L" Level output	VOL	-	-	-	0.4	V
Backlight Supply Voltage	VLED		-	5.0	-	V
Backlight Supply Current	ILED	VLED=5.0V	-	45	-	mA

Optical Characteristics

Item	Symbol	Condition	Min.	Typ.	Max.	Unit
Viewing Angle - Vertical (Top)	AV	Cr ≥ 3	-	10	-	°
Viewing Angle - Vertical (Bottom)	AV	Cr ≥ 3	-	60	-	°
Viewing Angle - Horizontal (Left)	AH	Cr ≥ 3	-	45	-	°
Viewing Angle - Horizontal (Right)	AH	Cr ≥ 3	-	45	-	°
Contrast Ratio	Cr		-	5	-	-
Response Time (rise)	Tr	-	-	100	150	ms
Response Time (fall)	Tf	-	-	150	200	ms

Controller Information

Built-in SBN1661G_M02. Download specification at http://www.newhavendisplay.com/app_notes/SBN1661G.pdf

Timing Characteristics

AC timing for interface with a 68-type microcontroller

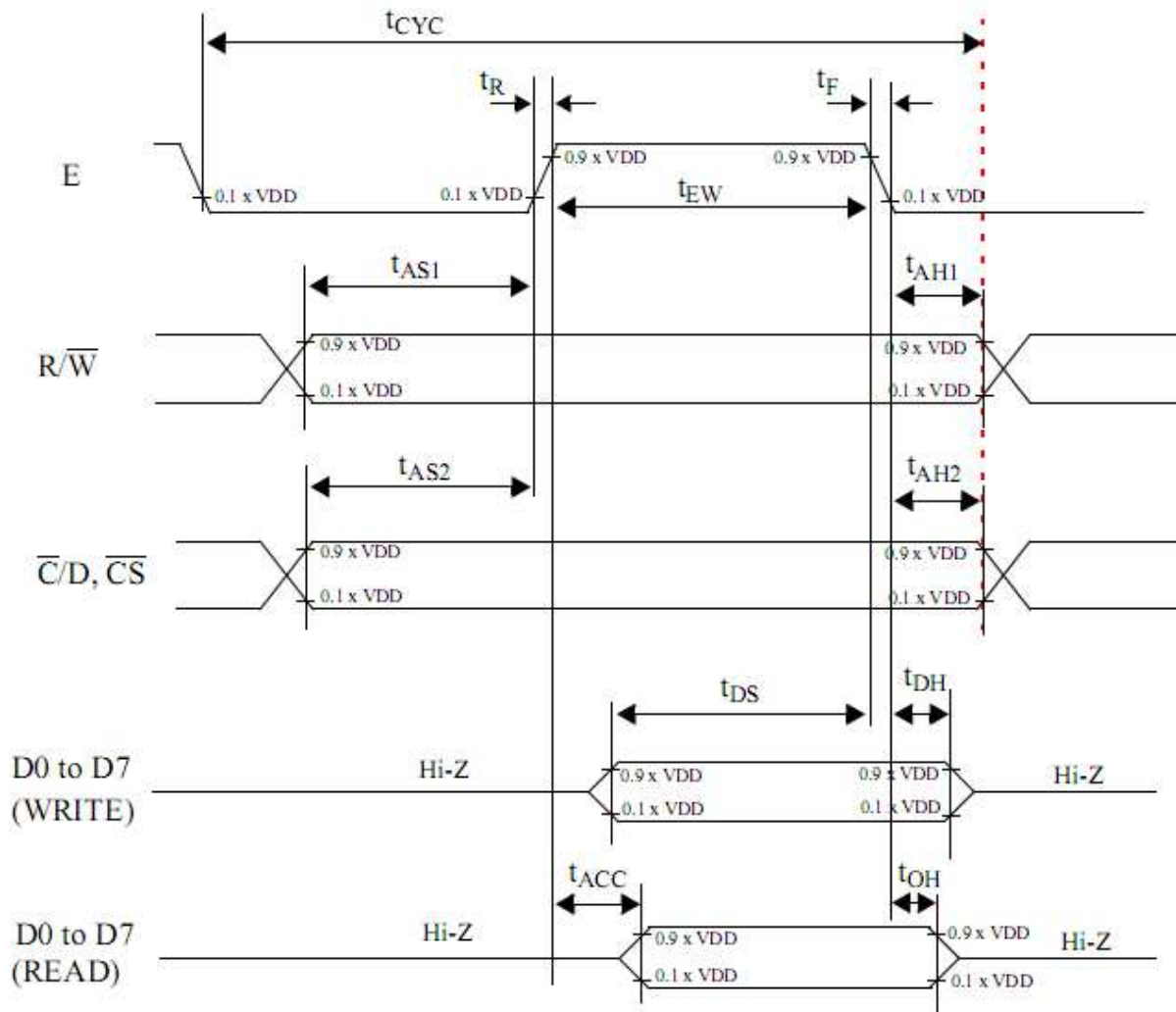

$V_{DD} = 5\text{ V} \pm 10\%$; $V_{SS} = 0\text{ V}$; $T_{amb} = -20\text{ }^{\circ}\text{C}$ to $+75\text{ }^{\circ}\text{C}$.

symbol	parameter	min.	max.	test conditons	unit
t_{AS1}	Address set-up time with respect to $\overline{R/\overline{W}}$	20			ns
t_{AS2}	Address set-up time with respect to $\overline{C/D}, \overline{CS}$	20			ns
t_{AH1}	Address hold time with respect to $\overline{R/\overline{W}}$	10			ns
t_{AH2}	Address hold time respect with to $\overline{C/D}, \overline{CS}$	10			ns
t_F, t_R	Enable (E) pulse falling/rising time		15		ns
t_{CYC}	System cycle time	1000		Note 1	ns
t_{EWR}	Enable pulse width for READ	100			ns
t_{EWW}	Enable pulse width for WRITE	80			ns
t_{DS}	Data setup time	80			ns
t_{DH}	Data hold time	10			ns
t_{ACC}	Data access time		90	CL= 100 pF.	ns
t_{OH}	Data output hold time	10	60	Refer to Fig. 23.	ns

Table of Commands

COMMAND	COMMAND CODE								FUNCTION
	D7	D6	D5	D4	D3	D2	D1	D0	
Write Display Data	Data to be written into the Display Data Memory.								Write a byte of data to the Display Data Memory.
Read Display Data	Data read from the Display Data Memory.								Read a byte of data from the Display Data Memory.
Read-Modify-Write	1	1	1	0	0	0	0	0	Start Read-Modify-Write operation.
END	1	1	1	0	1	1	1	0	Stop Read-Modify-Write operation.
Software Reset	1	1	1	0	0	0	1	0	Software Reset.

Example Initialization Program:

```
/******  
void Comleft(char i)  
{  
  P1 = i;  
  R_W = 0;  
  D_I = 0;  
  E1 = 1;  
  delay(2);  
  E1 = 0;  
}  
  
void Comright(char i)  
{  
  P1 = i;  
  R_W = 0;  
  D_I = 0;  
  E2 = 1;  
  delay(2);  
  E2 = 0;  
}  
  
void Writeleft(char i)  
{  
  P1 = i;  
  R_W = 0;  
  D_I = 1;  
  E1 = 1;  
  delay(2);  
  E1 = 0;  
}  
  
void Writerright(char i)  
{  
  P1 = i;  
  R_W = 0;  
  D_I = 1;  
  E2 = 1;  
  delay(2);  
  E2 = 0;  
}  
/******  
void bothSides(char i)  
{  
  Comleft(i);  
  Comright(i);  
}  
/******  
  
void init()  
{  
  P1 = 0;  
  P3 = 0;  
  RST = 0; // Reset RST  
  delay(1);  
  RST = 1; // Reset RST= M68 Interface  
  delay(10);  
  D_I = 0;  
  E1 = 1;  
  E2 = 1;  
  R_W = 1;  
  
  bothSides(0xE2);  
  delay(10);  
  bothSides(0xA4);  
  bothSides(0xA9);  
  bothSides(0xA0);  
  bothSides(0xEE);  
  bothSides(0xC0);  
  bothSides(0xAF);  
}  
/******
```

Quality Information

Test Item	Content of Test	Test Condition	Note
High Temperature storage	Endurance test applying the high storage temperature for a long time.	+80°C , 200hrs	2
Low Temperature storage	Endurance test applying the low storage temperature for a long time.	-30°C , 200hrs	1,2
High Temperature Operation	Endurance test applying the electric stress (voltage & current) and the high thermal stress for a long time.	+70°C 200hrs	2
Low Temperature Operation	Endurance test applying the electric stress (voltage & current) and the low thermal stress for a long time.	-20°C , 200hrs	1,2
High Temperature / Humidity Operation	Endurance test applying the electric stress (voltage & current) and the high thermal with high humidity stress for a long time.	+60°C , 90% RH , 96hrs	1,2
Thermal Shock resistance	Endurance test applying the electric stress (voltage & current) during a cycle of low and high thermal stress.	-20°C,30min -> 25°C,5min -> 70°C,30min = 1 cycle 10 cycles	
Vibration test	Endurance test applying vibration to simulate transportation and use.	10-55Hz , 15mm amplitude. 60 sec in each of 3 directions X,Y,Z For 15 minutes	3
Static electricity test	Endurance test applying electric static discharge.	VS=800V, RS=1.5kΩ, CS=100pF One time	

Note 1: No condensation to be observed.

Note 2: Conducted after 4 hours of storage at 25°C, 0%RH.

Note 3: Test performed on product itself, not inside a container.

Precautions for using LCDs/LCMs

See Precautions at www.newhavendisplay.com/specs/precautions.pdf

Warranty Information and Terms & Conditions

http://www.newhavendisplay.com/index.php?main_page=terms