



Chipsmall Limited consists of a professional team with an average of over 10 year of expertise in the distribution of electronic components. Based in Hongkong, we have already established firm and mutual-benefit business relationships with customers from,Europe,America and south Asia,supplying obsolete and hard-to-find components to meet their specific needs.

With the principle of “Quality Parts,Customers Priority,Honest Operation,and Considerate Service”,our business mainly focus on the distribution of electronic components. Line cards we deal with include Microchip,ALPS,ROHM,Xilinx,Pulse,ON,Everlight and Freescale. Main products comprise IC,Modules,Potentiometer,IC Socket,Relay,Connector.Our parts cover such applications as commercial,industrial, and automotives areas.

We are looking forward to setting up business relationship with you and hope to provide you with the best service and solution. Let us make a better world for our industry!



Contact us

Tel: +86-755-8981 8866 Fax: +86-755-8427 6832

Email & Skype: info@chipsmall.com Web: www.chipsmall.com

Address: A1208, Overseas Decoration Building, #122 Zhenhua RD., Futian, Shenzhen, China



NHD-12864MZ-FSW-GBW-L

Graphic Liquid Crystal Display Module

NHD-	Newhaven Display
12864-	128 x 64 pixels
MZ-	Model
F-	Transflective
SW-	Side White LED Backlight
G-	STN- Gray
B-	6:00 view
W-	Wide Temperature (-20°C ~ +70°C)
L-	Low Power
	RoHS Compliant

Newhaven Display International, Inc.

2511 Technology Drive, Suite 101

Elgin IL, 60124

Ph: 847-844-8795

Fax: 847-844-8796

www.newhavendisplay.com

nhtech@newhavendisplay.com

nhsales@newhavendisplay.com

Document Revision History

Revision	Date	Description	Changed by
0	12/8/2008	Initial Release	-
1	3/17/2010	User guide reformat	BE
2	3/19/2010	Mechanical Drawing updated	BE
3	4/14/2010	Block diagram/initialization updated	BE
4	5/13/2010	Pin Description updated	BE
5	12/17/12	Controller information updated	AK

Functions and Features

- 128 x 64 pixels
- Built-in NT7108C controller
- +5.0V power supply
- 1/64 duty cycle, 1/9 bias
- RoHS Compliant

Mechanical Drawing

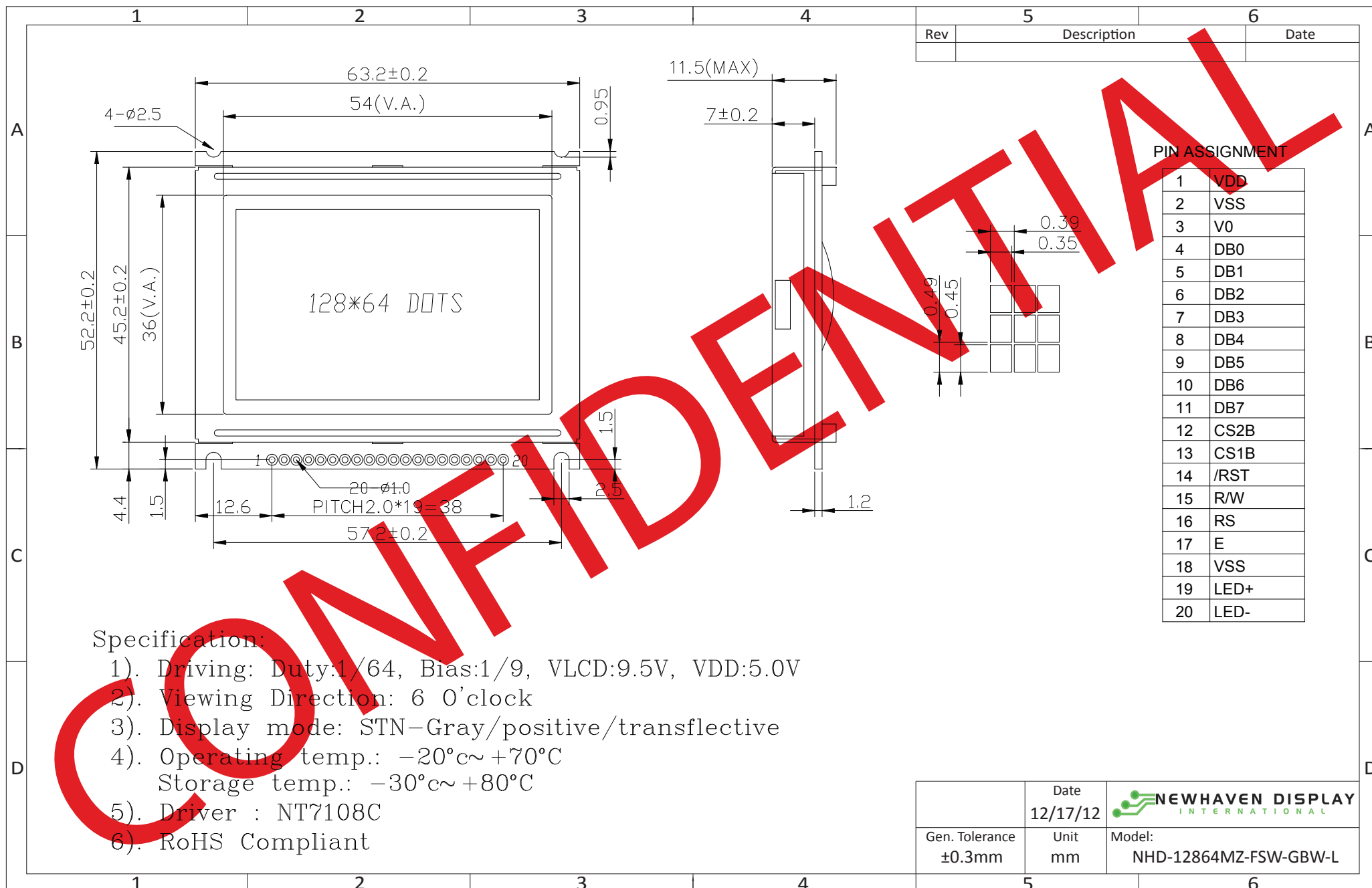

The drawing contained herein is the exclusive property of Newhaven Display International, Inc. and shall not be copied, reproduced, and/or disclosed in any format without permission.

Pin Description and Wiring Diagram

Pin No.	Symbol	External Connection	Function Description
1	VDD	Power Supply	Power supply for logic (+5.0V)
2	VSS	Power Supply	Ground
3	V0	Adj. Power Supply	Power supply for contrast (approx. -4.5V)
4-11	DB0-DB7	MPU	Bi-directional 8-bit data bus
12	CS2B	MPU	Active LOW Chip Select Signal for RIGHT half of LCD
13	CS1B	MPU	Active LOW Chip Select Signal for LEFT half of LCD
14	/RST	MPU	Active LOW Reset signal
15	R/W	MPU	Read/Write select signal. R/W=1: Read R/W: =0: Write
16	RS	MPU	Register select: 1=Data, 0=Instruction
17	E	MPU	Operation enable signal. Falling edge triggered.
18	VSS	Power Supply	Ground
19	LED+	Power Supply	Power supply for LED Backlight (+5.0V via on-board resistor)
20	LED-	Power Supply	Ground for Backlight

Recommended LCD connector: 2.0mm pitch pins

Backlight connector: - Mates with: -

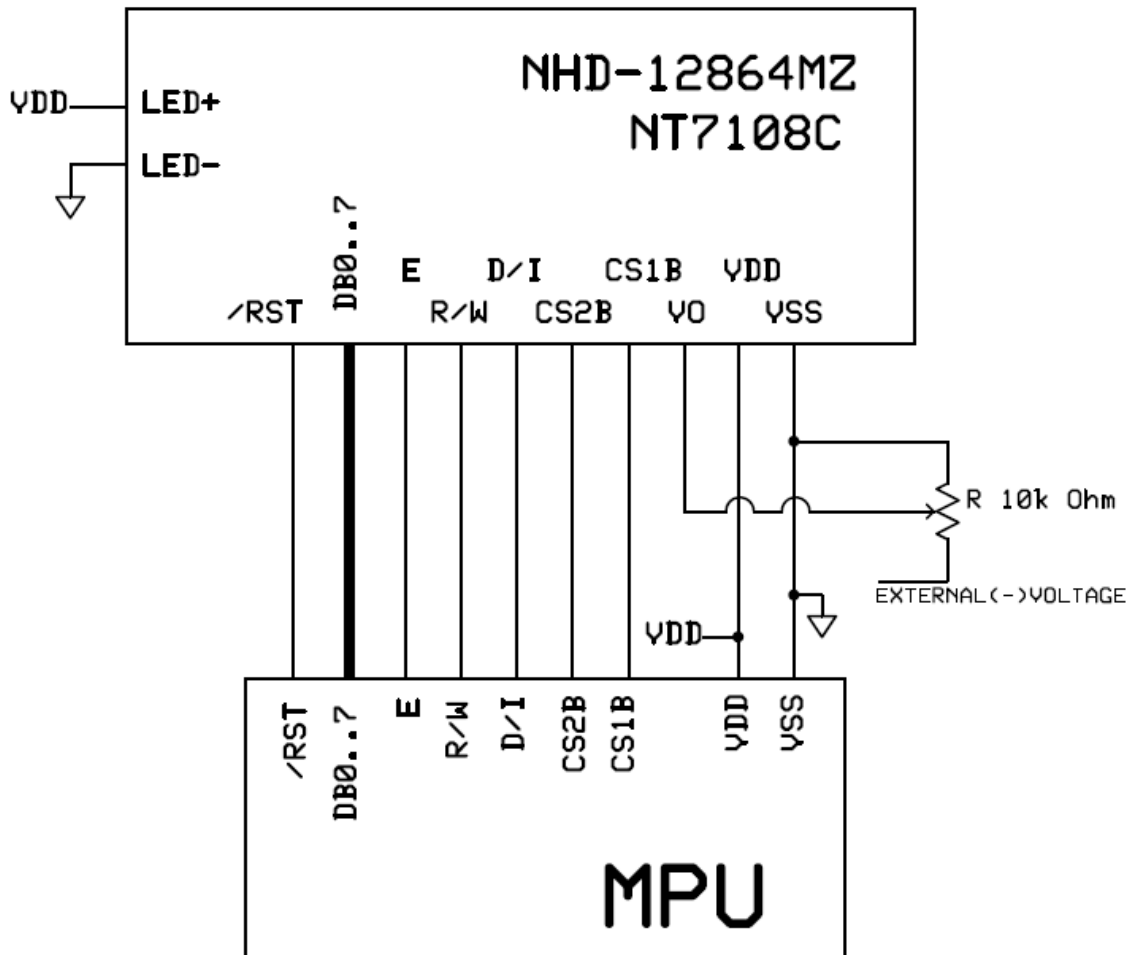

Electrical Characteristics

Item	Symbol	Condition	Min.	Typ.	Max.	Unit
Operating Temperature Range	Top	Absolute Max	-20	-	+70	°C
Storage Temperature Range	Tst	Absolute Max	-30	-	+80	°C
Supply Voltage	VDD		4.7	5.0	5.5	V
Supply Current	IDD	VDD=5.0V	-	2.5	3.5	mA
Supply for LCD (contrast)	VDD-V0	Ta=25°	-	9.5	9.8	V
"H" Level input	VIH		0.7*VDD	-	VDD	V
"L" Level input	VIL	-	0	-	0.3*VDD	V
"H" Level output	VOH	-	2.4	-	-	V
"L" Level output	VOL	-	-	-	0.4	V
Backlight Supply Voltage	VLED	-	-	5.0	-	V
Backlight Supply Current	ILED	VLED=5.0V	-	30	-	mA

Optical Characteristics

Item	Symbol	Condition	Min.	Typ.	Max.	Unit
Viewing Angle – Top		Cr ≥ 2	-	35	-	°
Viewing Angle – Bottom			-	60	-	°
Viewing Angle – Left			-	40	-	°
Viewing Angle – Right			-	40	-	°
Contrast Ratio	Cr		3	5	-	-
Response Time (rise)	Tr	-	-	150	250	ms
Response Time (fall)	Tf	-	-	200	300	ms

Controller Information

Built-in NT7108C controller.

Please download specification at http://www.newhavendisplay.com/app_notes/NT7108.pdf

Table of Commands

Instruction	RS	R/W	DB7	DB6	DB5	DB4	DB3	DB2	DB1	DB0	Function	
Display on/off	L	L	L	L	H	H	H	H	H	L/H	Controls the display on or off. Internal status and display RAM data is not affected. L:OFF, H:ON	
Set address (Y address)	L	L	L	H	Y address (0-63)						Sets the Y address in the Y address counter.	
Set page (X address)	L	L	H	L	H	H	H	Page (0-7)			Sets the X address at the X address register.	
Display Start line (Z address)	L	L	H	H	Display start line (0-63)						Indicates the display data RAM displayed at the top of the screen.	
Status read	L	H	Busy	L	On/Off	Reset	L	L	L	L	Read status. BUSY L: Ready H: In operation ON/OFF L: Display ON H: Display OFF RESET L: Normal H: Reset	
Write display data	H	L	Write data									Writes data (DB0: 7) into display data RAM. After writing instruction, Y address is increased by 1 automatically.
Read display data	H	H	Read data									Reads data (DB0: 7) from display data RAM to the data bus.

Timing Characteristics

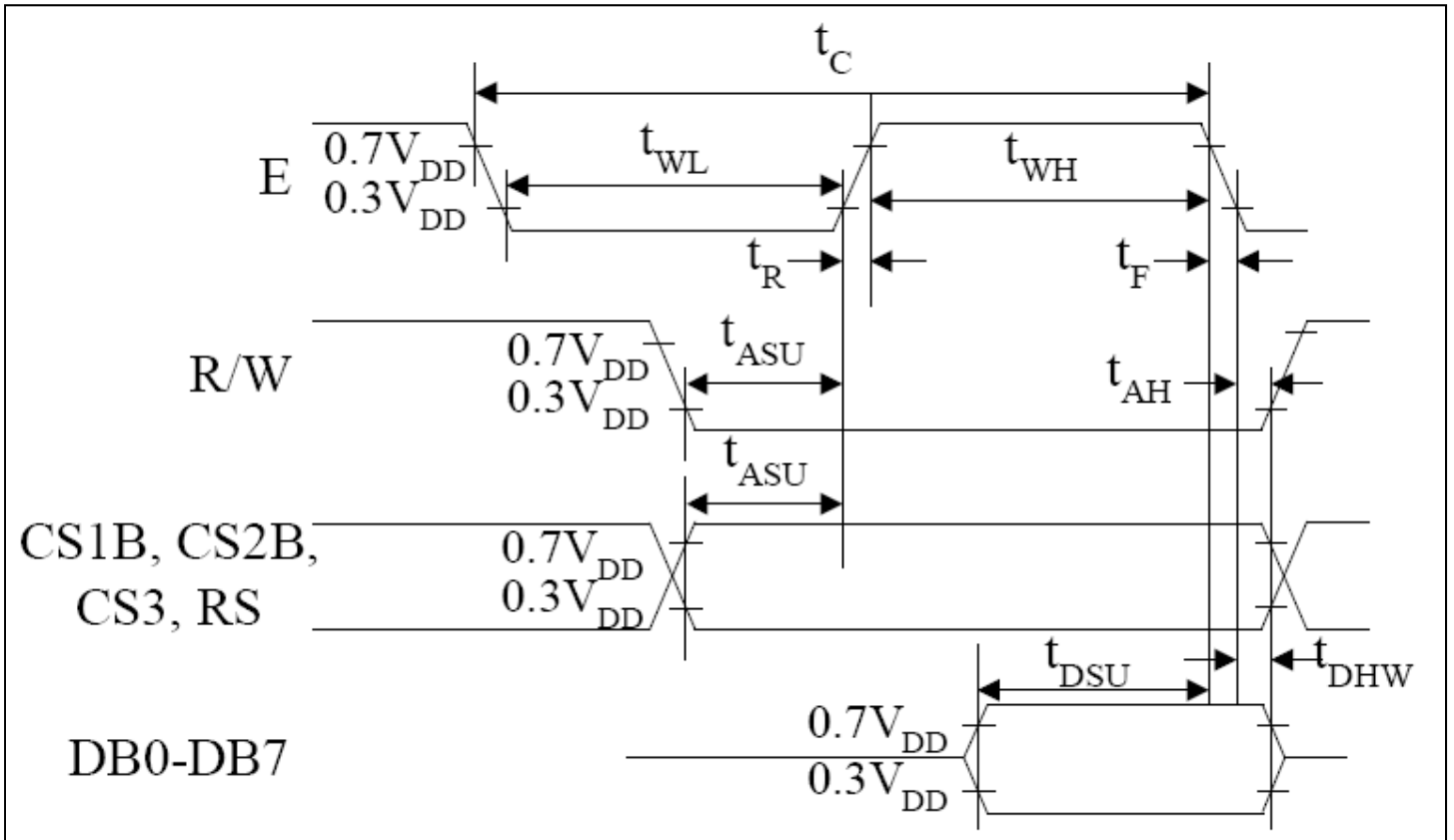

Characteristic	Symbol	Min	Type	Max	Unit
E cycle	t_c	1000	-	-	ns
E high level width	t_{WH}	450	-	-	
E low level width	t_{WL}	450	-	-	
E rise time	t_R	-	-	25	
E fall time	t_F	-	-	25	
Address set-up time	t_{ASU}	140	-	-	
Address hold time	t_{AH}	10	-	-	
Data set-up time	t_{DSU}	200	-	-	
Data delay time	t_D	-	-	320	
Data hold time (write)	t_{DHW}	10	-	-	
Data hold time (read)	t_{DHR}	20	-	-	

Example Initialization Program

```
'-----  
'DB0-DB7  7-14          P1  
'CS2      16           P3.6  
'CS1      15           P3.1  
'RST      17           P3.2  
'R/W      5            P3.7  
'D/I      4            P3.0  
'E        6            P3.4  
'-----  
Sub Init  
  Reset P3.2  
  Set P3.2  
  Reset P3.4  
  Reset P3.0  
  Reset P3.7  
  Reset P3.6  
  Reset P3.1  
  A = &H3F  
  Call Comleft           'display on  
  Call Comright         'display on  
End Sub  
'-----  
Sub Comleft  
  P1 = A  
  Set P3.6  
  Reset P3.0  
  Set P3.4  
  Reset P3.4  
  Reset P3.6  
End Sub  
  
Sub Comright  
  P1 = A  
  Set P3.1  
  Reset P3.0  
  Set P3.4  
  Reset P3.4  
  Reset P3.1  
End Sub  
  
Sub Writeleft  
  P1 = A  
  Set P3.6  
  Set P3.0  
  Set P3.4  
  Reset P3.4  
  Reset P3.6  
End Sub  
  
Sub Writeright  
  P1 = A  
  Set P3.1  
  Set P3.0  
  Set P3.4  
  Reset P3.4  
  Reset P3.1  
End Sub
```

Quality Information

Test Item	Content of Test	Test Condition	Note
High Temperature storage	Endurance test applying the high storage temperature for a long time.	+80°C , 200hrs	2
Low Temperature storage	Endurance test applying the low storage temperature for a long time.	-30°C , 200hrs	1,2
High Temperature Operation	Endurance test applying the electric stress (voltage & current) and the high thermal stress for a long time.	+70°C 200hrs	2
Low Temperature Operation	Endurance test applying the electric stress (voltage & current) and the low thermal stress for a long time.	-20°C , 200hrs	1,2
High Temperature / Humidity Operation	Endurance test applying the electric stress (voltage & current) and the high thermal with high humidity stress for a long time.	+60°C , 90% RH , 96hrs	1,2
Thermal Shock resistance	Endurance test applying the electric stress (voltage & current) during a cycle of low and high thermal stress.	-20°C,30min -> 25°C,5min -> 70°C,30min = 1 cycle 10 cycles	
Vibration test	Endurance test applying vibration to simulate transportation and use.	10-55Hz , 15mm amplitude. 60 sec in each of 3 directions X,Y,Z For 15 minutes	3
Static electricity test	Endurance test applying electric static discharge.	VS=800V, RS=1.5kΩ, CS=100pF One time	

Note 1: No condensation to be observed.

Note 2: Conducted after 4 hours of storage at 25°C, 0%RH.

Note 3: Test performed on product itself, not inside a container.

Precautions for using LCDs/LCMs

See Precautions at www.newhavendisplay.com/specs/precautions.pdf

Warranty Information and Terms & Conditions

http://www.newhavendisplay.com/index.php?main_page=terms