



Chipsmall Limited consists of a professional team with an average of over 10 year of expertise in the distribution of electronic components. Based in Hongkong, we have already established firm and mutual-benefit business relationships with customers from,Europe,America and south Asia,supplying obsolete and hard-to-find components to meet their specific needs.

With the principle of “Quality Parts,Customers Priority,Honest Operation,and Considerate Service”,our business mainly focus on the distribution of electronic components. Line cards we deal with include Microchip,ALPS,ROHM,Xilinx,Pulse,ON,Everlight and Freescale. Main products comprise IC,Modules,Potentiometer,IC Socket,Relay,Connector.Our parts cover such applications as commercial,industrial, and automotives areas.

We are looking forward to setting up business relationship with you and hope to provide you with the best service and solution. Let us make a better world for our industry!



## Contact us

Tel: +86-755-8981 8866 Fax: +86-755-8427 6832

Email & Skype: info@chipsmall.com Web: www.chipsmall.com

Address: A1208, Overseas Decoration Building, #122 Zhenhua RD., Futian, Shenzhen, China



# NHD-2.4-240320CF-CTXI#-FT

## TFT (Thin-Film Transistor) Liquid Crystal Display Module

NHD-	Newhaven Display
2.4-	2.4" Diagonal
240320-	240 x 320 Pixels (Portrait Mode)
CF-	Model
C-	Built-in Controller
T-	White LED Backlight
X-	TFT
I-	6:00 Optimal View, Wide Temperature
#-	<b>RoHS Compliant</b>
F-	FFC ZIF Connection Style
T-	4-wire Resistive Touch Panel

### Newhaven Display International, Inc.

2661 Galvin Ct.

Elgin IL, 60124

Ph: 847-844-8795

Fax: 847-844-8796

[www.newhavendisplay.com](http://www.newhavendisplay.com)

[nhtech@newhavendisplay.com](mailto:nhtech@newhavendisplay.com)

[nhsales@newhavendisplay.com](mailto:nhsales@newhavendisplay.com)

## Document Revision History

Revision	Date	Description	Changed by
0	11/21/14	Initial Release	AK
1	10/1/15	Mechanical Drawing, Supply Voltage, Updated	SB
2	11/6/15	Mechanical Drawing Updated, Datasheet Reformat	SB
3	4/7/16	Viewing Angle Clarification	SB
4	5/31/16	Supply Voltage Updated	SB
5	6/10/16	Updated Brightness Rating	SB
6	7/11/16	Touch Panel FFC length increased to 15mm	SB

## Functions and Features

- 240 x 320 pixels
- LED backlight
- 3.3V power supply
- 8-bit or 16-bit Parallel MPU interface
- FFC ZIF I/O connection
- Built-in ST7789S controller
- 262K colors
- 4-wire Resistive Touch Panel

# Mechanical Drawing

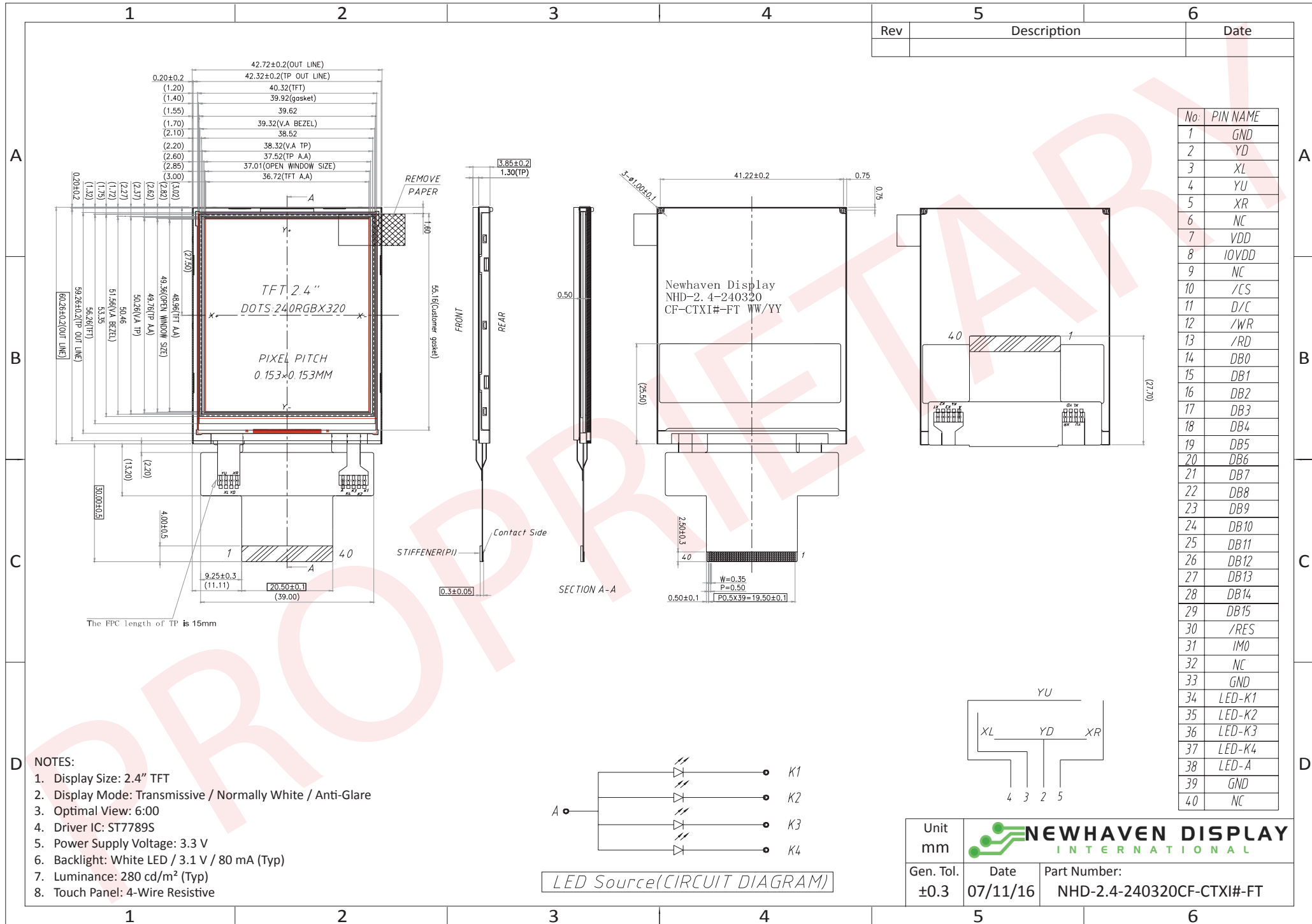

Rev	Description	Date

No.	PIN NAME
1	GND
2	YD
3	XL
4	YU
5	XR
6	NC
7	VDD
8	IOVDD
9	NC
10	/CS
11	D/C
12	/WR
13	/RD
14	DB0
15	DB1
16	DB2
17	DB3
18	DB4
19	DB5
20	DB6
21	DB7
22	DB8
23	DB9
24	DB10
25	DB11
26	DB12
27	DB13
28	DB14
29	DB15
30	/RES
31	IM0
32	NC
33	GND
34	LED-K1
35	LED-K2
36	LED-K3
37	LED-K4
38	LED-A
39	GND
40	NC

- NOTES:
1. Display Size: 2.4" TFT
  2. Display Mode: Transmissive / Normally White / Anti-Glare
  3. Optimal View: 6:00
  4. Driver IC: ST7789S
  5. Power Supply Voltage: 3.3 V
  6. Backlight: White LED / 3.1 V / 80 mA (Typ)
  7. Luminance: 280 cd/m<sup>2</sup> (Typ)
  8. Touch Panel: 4-Wire Resistive

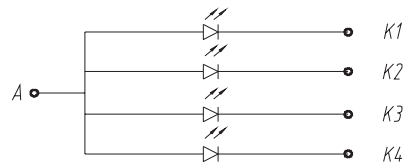

LED Source(CIRCUIT DIAGRAM)

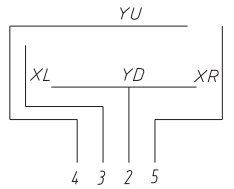

Unit mm		
Gen. Tol. ±0.3	Date 07/11/16	Part Number: NHD-2.4-240320CF-CTXI#-FT

## Pin Description

Pin No.	Symbol	External Connection	Function Description
1	GND	Power Supply	Ground
2	YD	Touch Controller	Touch Panel – Down
3	XL	Touch Controller	Touch Panel – Left
4	YU	Touch Controller	Touch Panel – Up
5	XR	Touch Controller	Touch Panel – Right
6	NC	-	No Connect
7	VDD	Power Supply	Supply Voltage for LCD (3.3V)
8	IOVDD	Power Supply	Supply Voltage for Logic (1.8V)
9	NC	-	No Connect
10	/CS	MPU	Active LOW Chip Select signal (can tie to GND)
11	D/C	MPU	Data / Command selection: '1' = Data ; '0' = Command
12	/WR	MPU	Active LOW Write signal
13	/RD	MPU	Active LOW Read signal
14	DB0	MPU	Bi-directional data bus  8-bit: use DB8-DB15 16-bit: use DB0-DB15
15	DB1	MPU	
16	DB2	MPU	
17	DB3	MPU	
18	DB4	MPU	
19	DB5	MPU	
20	DB6	MPU	
21	DB7	MPU	
22	DB8	MPU	
23	DB9	MPU	
24	DB10	MPU	
25	DB11	MPU	
26	DB12	MPU	
27	DB13	MPU	
28	DB14	MPU	
29	DB15	MPU	
30	/RES	MPU	Active LOW Reset signal
31	IM0	MPU	IM0=0: 16-bit i80      IM0=1: 8-bit i80
32	NC	-	No Connect
33	GND	Power Supply	Ground
34	LED-K1	Power Supply	Backlight Cathode (Ground)
35	LED-K2	Power Supply	Backlight Cathode (Ground)
36	LED-K3	Power Supply	Backlight Cathode (Ground)
37	LED-K4	Power Supply	Backlight Cathode (Ground)
38	LED-A	Power Supply	Backlight Anode (3.1V)
39	GND	Power Supply	Ground
40	NC	-	No Connect

**Recommended LCD connector:** 40-pin, 0.5mm pitch FFC connector

**Molex P/N:** 54132-4062 or similar

# Wiring Diagram

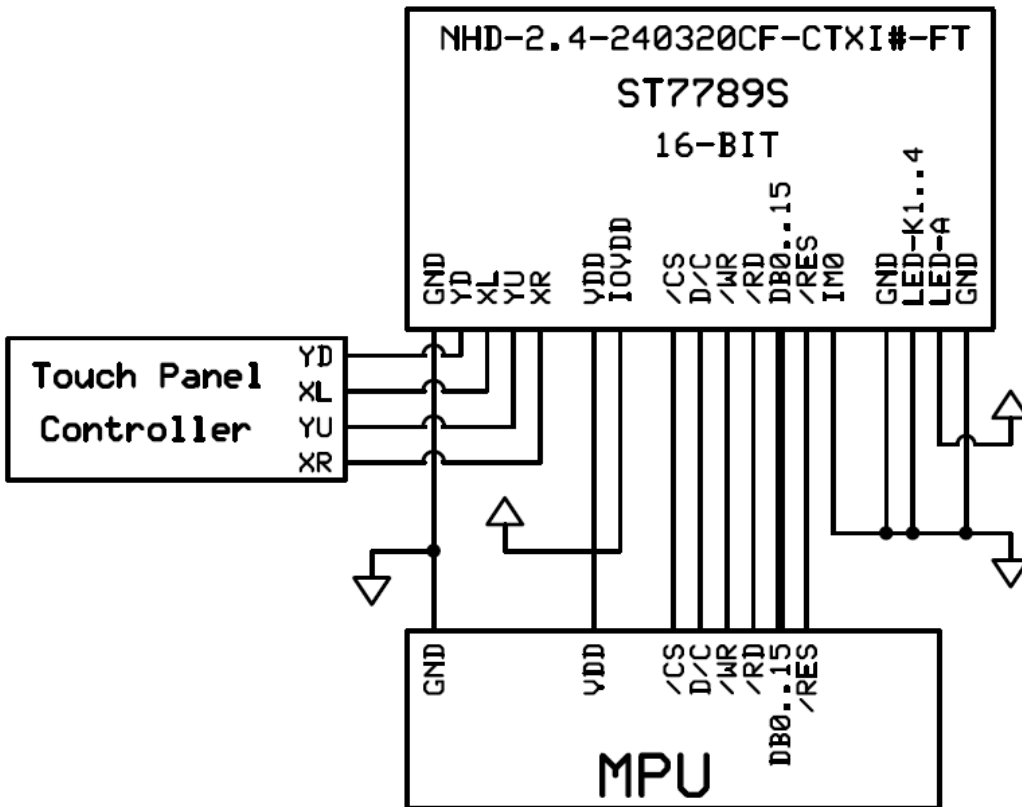
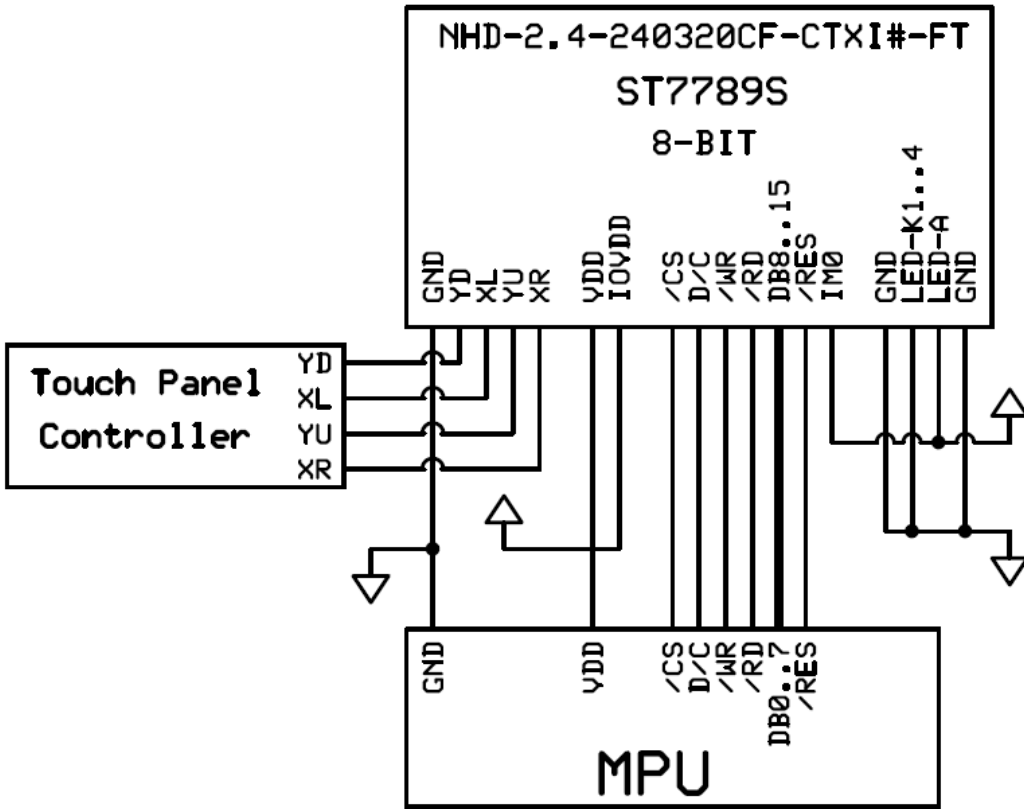



## Electrical Characteristics

Item	Symbol	Condition	Min.	Typ.	Max.	Unit
Operating Temperature Range	T <sub>OP</sub>	Absolute Max	-20	-	+70	°C
Storage Temperature Range	T <sub>ST</sub>	Absolute Max	-30	-	+80	°C
Supply Voltage for LCD	V <sub>DD</sub>	-	2.4	3.3	3.5	V
Supply Voltage for Logic	IOV <sub>DD</sub>	-	1.65	1.8	3.3	V
Supply Current	I <sub>DD</sub>	V <sub>DD</sub> = 3.3V	-	6.0	-	mA
"H" Level input	V <sub>IH</sub>	-	0.7 * V <sub>DD</sub>	-	V <sub>DD</sub>	V
"L" Level input	V <sub>IL</sub>	-	GND	-	0.3 * V <sub>DD</sub>	V
"H" Level output	V <sub>OH</sub>	-	0.8 * V <sub>DD</sub>	-	V <sub>DD</sub>	V
"L" Level output	V <sub>OL</sub>	-	GND	-	0.2 * V <sub>DD</sub>	V
Backlight Supply Voltage	V <sub>LED</sub>	-	2.8	3.1	3.5	V
Backlight Supply Current	I <sub>LED</sub>	V <sub>LED</sub> = 3.1V	-	80	100	mA
Backlight Lifetime	-	I <sub>LED</sub> = 100mA T <sub>OP</sub> = 25°C	20,000	50,000	-	Hrs.

## Optical Characteristics

Item	Symbol	Condition	Min.	Typ.	Max.	Unit
Optimal Viewing Angles	Top	CR ≥ 10	50	50	-	°
	Bottom		55	55	-	°
	Left		55	55	-	°
	Right		55	55	-	°
Contrast Ratio	CR	-	150	200	-	-
Luminance	L <sub>V</sub>	I <sub>LED</sub> = 80 mA	200	280	360	cd/m <sup>2</sup>
Response Time	Rise	T <sub>OP</sub> = 25°C	-	4	8	ms
	Fall		-	12	24	ms

## Touch Panel Characteristics

Item	Min.	Typ.	Max.	Unit
Linearity	-	-	1.5	%
Circuit Resistance – X-Axis	200	-	600	Ω
Circuit Resistance – Y-Axis	250	-	900	Ω
Insulation Resistance	20	-	-	MΩ
Operating Voltage	-	-	5	V
Chattering	-	-	15	ms
Activation Force	100	-	-	g
Pen Writing Durability	100,000	-	-	Characters
Pitting Durability	1,000,000	-	-	Touches
Surface Hardness	3	-	-	H

## Controller Information

Built-in ST7789S controller.

Please download specification at [http://www.newhavendisplay.com/app\\_notes/ST7789S.pdf](http://www.newhavendisplay.com/app_notes/ST7789S.pdf)

## Table of Commands

Please download specification at [http://www.newhavendisplay.com/app\\_notes/ST7789S.pdf](http://www.newhavendisplay.com/app_notes/ST7789S.pdf)

# Timing Characteristics

## Parallel 18/16/9/8-bit Interface Timing Characteristics (8080-II system)

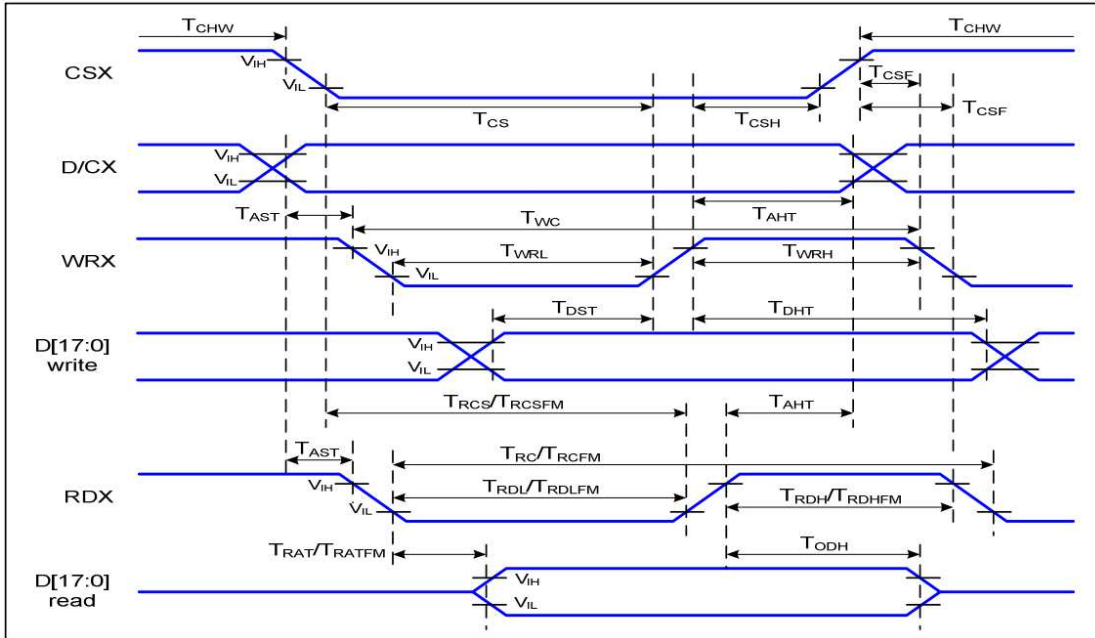



Signal	Symbol	Parameter	Min	Max	Unit	Description
D/CX	$T_{AST}$	Address setup time	0		ns	-
	$T_{AHT}$	Address hold time (Write/Read)	10		ns	
CSX	$T_{CHW}$	Chip select "H" pulse width	0		ns	-
	$T_{CS}$	Chip select setup time (Write)	15		ns	
	$T_{RCS}$	Chip select setup time (Read ID)	45		ns	
	$T_{RCSFM}$	Chip select setup time (Read FM)	355		ns	
	$T_{CSF}$	Chip select wait time (Write/Read)	10		ns	
	$T_{CSH}$	Chip select hold time	10		ns	
WRX	$T_{WC}$	Write cycle	66		ns	
	$T_{WRH}$	Control pulse "H" duration	15		ns	
	$T_{WRL}$	Control pulse "L" duration	15		ns	
RDX (ID)	$T_{RC}$	Read cycle (ID)	160		ns	When read ID data
	$T_{RDH}$	Control pulse "H" duration (ID)	90		ns	
	$T_{RDL}$	Control pulse "L" duration (ID)	45		ns	
RDX (FM)	$T_{RCFM}$	Read cycle (FM)	450		ns	When read from frame memory
	$T_{RDHFM}$	Control pulse "H" duration (FM)	90		ns	
	$T_{RDLFM}$	Control pulse "L" duration (FM)	355		ns	
D[17:0]	$T_{DST}$	Data setup time	10		ns	For CL=30pF
	$T_{DHT}$	Data hold time	10		ns	
	$T_{RAT}$	Read access time (ID)		40	ns	
	$T_{RATFM}$	Read access time (FM)		340	ns	
	$T_{ODH}$	Output disable time	20	80	ns	

### Reset Timing

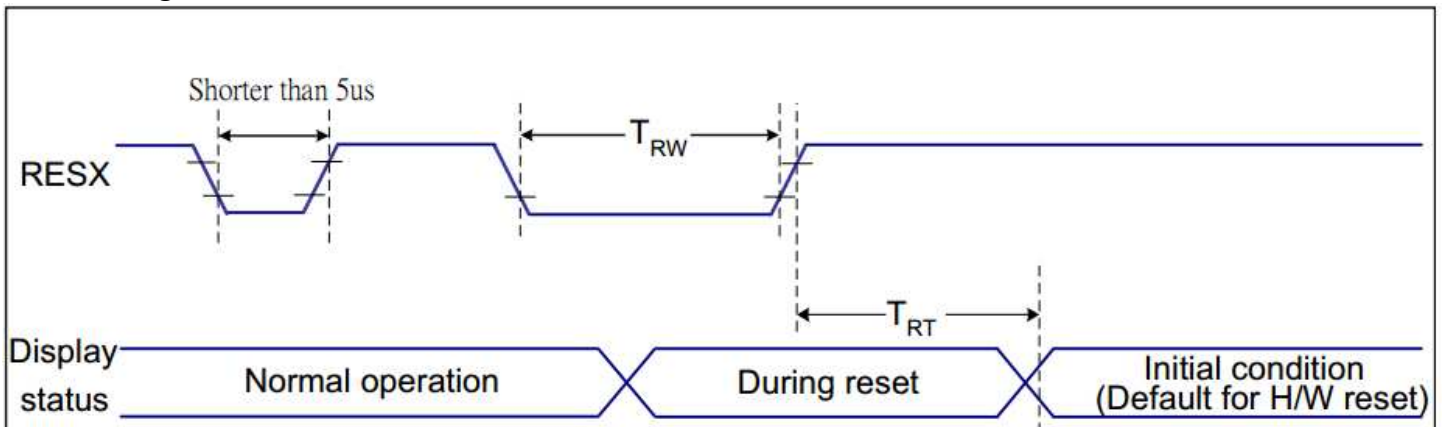

Related Pins	Symbol	Parameter	MIN	MAX	Unit
RESX	TRW	Reset pulse duration	10	-	us
	TRT	Reset cancel	-	5 (Note 1, 5)	ms
				120 (Note 1, 6, 7)	ms

### Power ON/OFF Sequence

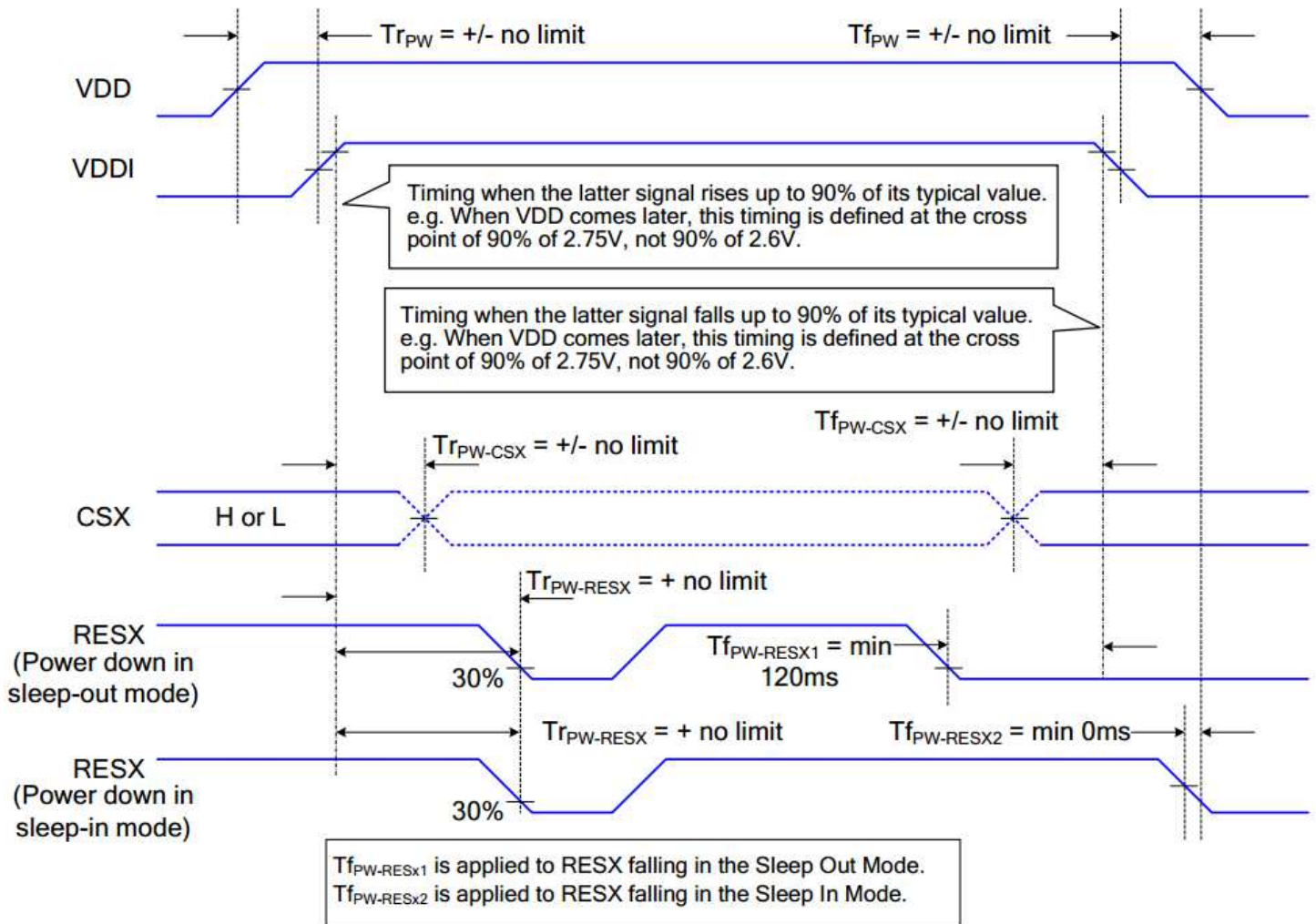

## Example Initialization Code

```

/*****/
void TFT_24_7789_Write_Command(unsigned int command)
{
  GPIO_ResetBits(GPIOC, CS1);
  GPIO_ResetBits(GPIOC, RS);
  GPIO_SetBits(GPIOC, nRD);
  GPIO_ResetBits(GPIOC, nWR);
  GPIO_Write(GPIOB, command);
  TFT_delay(10);
  GPIO_SetBits(GPIOC, nWR);
  TFT_delay(1);
}
/*****/
void TFT_24_7789_Write_Data(unsigned int data1)
{
  GPIO_Write(GPIOB, data1);
  GPIO_SetBits(GPIOC, RS);
  GPIO_ResetBits(GPIOC, nWR);
  TFT_delay(1);
  GPIO_SetBits(GPIOC, nWR);
}
/*****/
void TFT_24_7789_Init(void)

```

```

{
int n;
GPIO_ResetBits(GPIOC, CS1);
GPIO_SetBits(GPIOC, nRD);
GPIO_ResetBits(GPIOC, nWR);
GPIO_WriteBit(GPIOC, RES, Bit_RESET);
TFT_delay(100);
GPIO_WriteBit(GPIOC, RES, Bit_SET);
TFT_delay(100);
TFT_24_7789_Write_Command(0x0011); //exit SLEEP mode
TFT_delay(100);

TFT_24_7789_Write_Command(0x0036);
TFT_24_7789_Write_Data(0x0080); //MADCTL: memory data access control
TFT_24_7789_Write_Command(0x003A);
TFT_24_7789_Write_Data(0x0066); //COLMOD: Interface Pixel format
TFT_24_7789_Write_Command(0x00B2);
TFT_24_7789_Write_Data(0x000C);
TFT_24_7789_Write_Data(0x0C);
TFT_24_7789_Write_Data(0x00);
TFT_24_7789_Write_Data(0x33);
TFT_24_7789_Write_Data(0x33); //PORCTRK: Porch setting
TFT_24_7789_Write_Command(0x00B7);
TFT_24_7789_Write_Data(0x0035); //GCTRL: Gate Control
TFT_24_7789_Write_Command(0x00BB);
TFT_24_7789_Write_Data(0x002B); //VCOMS: VCOM setting
TFT_24_7789_Write_Command(0x00C0);
TFT_24_7789_Write_Data(0x002C); //LCMCTRL: LCM Control
TFT_24_7789_Write_Command(0x00C2);
TFT_24_7789_Write_Data(0x0001);
TFT_24_7789_Write_Data(0xFF); //VDVVRHEN: VDV and VRH Command Enable
TFT_24_7789_Write_Command(0x00C3);
TFT_24_7789_Write_Data(0x0011); //VRHS: VRH Set
TFT_24_7789_Write_Command(0x00C4);
TFT_24_7789_Write_Data(0x0020); //VDVS: VDV Set
TFT_24_7789_Write_Command(0x00C6);
TFT_24_7789_Write_Data(0x000F); //FRCTRL2: Frame Rate control in normal mode
TFT_24_7789_Write_Command(0x00D0);
TFT_24_7789_Write_Data(0x00A4);
TFT_24_7789_Write_Data(0xA1); //PWCTRL1: Power Control 1
TFT_24_7789_Write_Command(0x00E0);
TFT_24_7789_Write_Data(0x00D0);
TFT_24_7789_Write_Data(0x0000);
TFT_24_7789_Write_Data(0x0005);
TFT_24_7789_Write_Data(0x000E);
TFT_24_7789_Write_Data(0x0015);
TFT_24_7789_Write_Data(0x000D);
TFT_24_7789_Write_Data(0x0037);
TFT_24_7789_Write_Data(0x0043);
TFT_24_7789_Write_Data(0x0047);
TFT_24_7789_Write_Data(0x0009);
TFT_24_7789_Write_Data(0x0015);
TFT_24_7789_Write_Data(0x0012);
TFT_24_7789_Write_Data(0x0016);
TFT_24_7789_Write_Data(0x0019); //PVGAMCTRL: Positive Voltage Gamma control
TFT_24_7789_Write_Command(0x00E1);
TFT_24_7789_Write_Data(0x00D0);
TFT_24_7789_Write_Data(0x0000);
TFT_24_7789_Write_Data(0x0005);
TFT_24_7789_Write_Data(0x000D);
TFT_24_7789_Write_Data(0x000C);

```

```

TFT_24_7789_Write_Data(0x0006);
TFT_24_7789_Write_Data(0x002D);
TFT_24_7789_Write_Data(0x0044);
TFT_24_7789_Write_Data(0x0040);
TFT_24_7789_Write_Data(0x000E);
TFT_24_7789_Write_Data(0x001C);
TFT_24_7789_Write_Data(0x0018);
TFT_24_7789_Write_Data(0x0016);
TFT_24_7789_Write_Data(0x0019); //NVGAMCTRL: Negative Voltage Gamma control
TFT_24_7789_Write_Command(0x002A);
TFT_24_7789_Write_Data(0x0000);
TFT_24_7789_Write_Data(0x0000);
TFT_24_7789_Write_Data(0x0000);
TFT_24_7789_Write_Data(0x00EF); //X address set
TFT_24_7789_Write_Command(0x002B);
TFT_24_7789_Write_Data(0x0000);
TFT_24_7789_Write_Data(0x0000);
TFT_24_7789_Write_Data(0x0001);
TFT_24_7789_Write_Data(0x003F); //Y address set

TFT_delay(10);
}
/*****/

```

## Quality Information

Test Item	Content of Test	Test Condition	Note
High Temperature Storage	Endurance test applying the high storage temperature for a long time.	+80°C, 96hrs	2
Low Temperature Storage	Endurance test applying the low storage temperature for a long time.	-30°C, 96hrs	1,2
High Temperature Operation	Endurance test applying the electric stress (voltage & current) and the high thermal stress for a long time.	+70°C, 96hrs	2
Low Temperature Operation	Endurance test applying the electric stress (voltage & current) and the low thermal stress for a long time.	-20°C, 96hrs	1,2
High Temperature / Humidity Operation	Endurance test applying the electric stress (voltage & current) and the high thermal with high humidity stress for a long time.	+40°C, 90-95% RH, 96hrs	1,2
Thermal Shock resistance	Endurance test applying the electric stress (voltage & current) during a cycle of low and high thermal stress.	-20°C,30min -> 25°C,5min -> 70°C,30min -> 25°C,5min = 1 cycle. 10 cycles	
Vibration test	Endurance test applying vibration to simulate transportation and use.	10Hz-55Hz, 1.5mm amplitude. 2hrs in each of 3 directions X,Y,Z	3
Static electricity test	Endurance test applying electric static discharge.	VS=8KV, RS=330kΩ, CS=150pF Ten times	

**Note 1:** No condensation to be observed.

**Note 2:** Conducted after 4 hours of storage at 25°C, 0%RH.

**Note 3:** Test performed on product itself, not inside a container.

## **Precautions for using LCDs/LCMs**

See Precautions at [www.newhavendisplay.com/specs/precautions.pdf](http://www.newhavendisplay.com/specs/precautions.pdf)

## **Warranty Information**

See Terms & Conditions at [http://www.newhavendisplay.com/index.php?main\\_page=terms](http://www.newhavendisplay.com/index.php?main_page=terms)