



Chipsmall Limited consists of a professional team with an average of over 10 year of expertise in the distribution of electronic components. Based in Hongkong, we have already established firm and mutual-benefit business relationships with customers from,Europe,America and south Asia,supplying obsolete and hard-to-find components to meet their specific needs.

With the principle of “Quality Parts,Customers Priority,Honest Operation,and Considerate Service”,our business mainly focus on the distribution of electronic components. Line cards we deal with include Microchip,ALPS,ROHM,Xilinx,Pulse,ON,Everlight and Freescale. Main products comprise IC,Modules,Potentiometer,IC Socket,Relay,Connector.Our parts cover such applications as commercial,industrial, and automotives areas.

We are looking forward to setting up business relationship with you and hope to provide you with the best service and solution. Let us make a better world for our industry!



Contact us

Tel: +86-755-8981 8866 Fax: +86-755-8427 6832

Email & Skype: info@chipsmall.com Web: www.chipsmall.com

Address: A1208, Overseas Decoration Building, #122 Zhenhua RD., Futian, Shenzhen, China



NHD-3.5-320240MF-ASXN#-CTP

TFT (Thin-Film-Transistor) Color Liquid Crystal Display Module

NHD-	Newhaven Display
3.5-	3.5" Diagonal
320240-	320xRGBx240 Pixels
MF-	Model
A-	Built-in Driver / No Controller
S-	Sunlight Readable
X-	TFT
N-	TN, Wide Temperature
#-	RoHS Compliant
CTP-	Capacitive Touch Panel with Controller

Newhaven Display International, Inc.

2661 Galvin Ct.

Elgin IL, 60124

Ph: 847-844-8795

Fax: 847-844-8796

www.newhavendisplay.com

nhtech@newhavendisplay.com

nhsales@newhavendisplay.com

Document Revision History

Revision	Date	Description	Changed by
0	4/29/16	Initial Release	SB
1	6/30/16	Added Chromaticity	SB
2	9/22/16	Backlight and Supply Current Updated	SB

Functions and Features

- 320xRGBx240 resolution
- LED backlight
- 3.3V power supply
- 24-bit Parallel digital RGB interface (6.4MHz)
- Sunlight readable
- Capacitive touch panel with controller
 - 5 point multi-touch input
 - Gesture input
 - Zoom In/Out
 - Swipe Up/Down/Left/Right

Mechanical Drawing

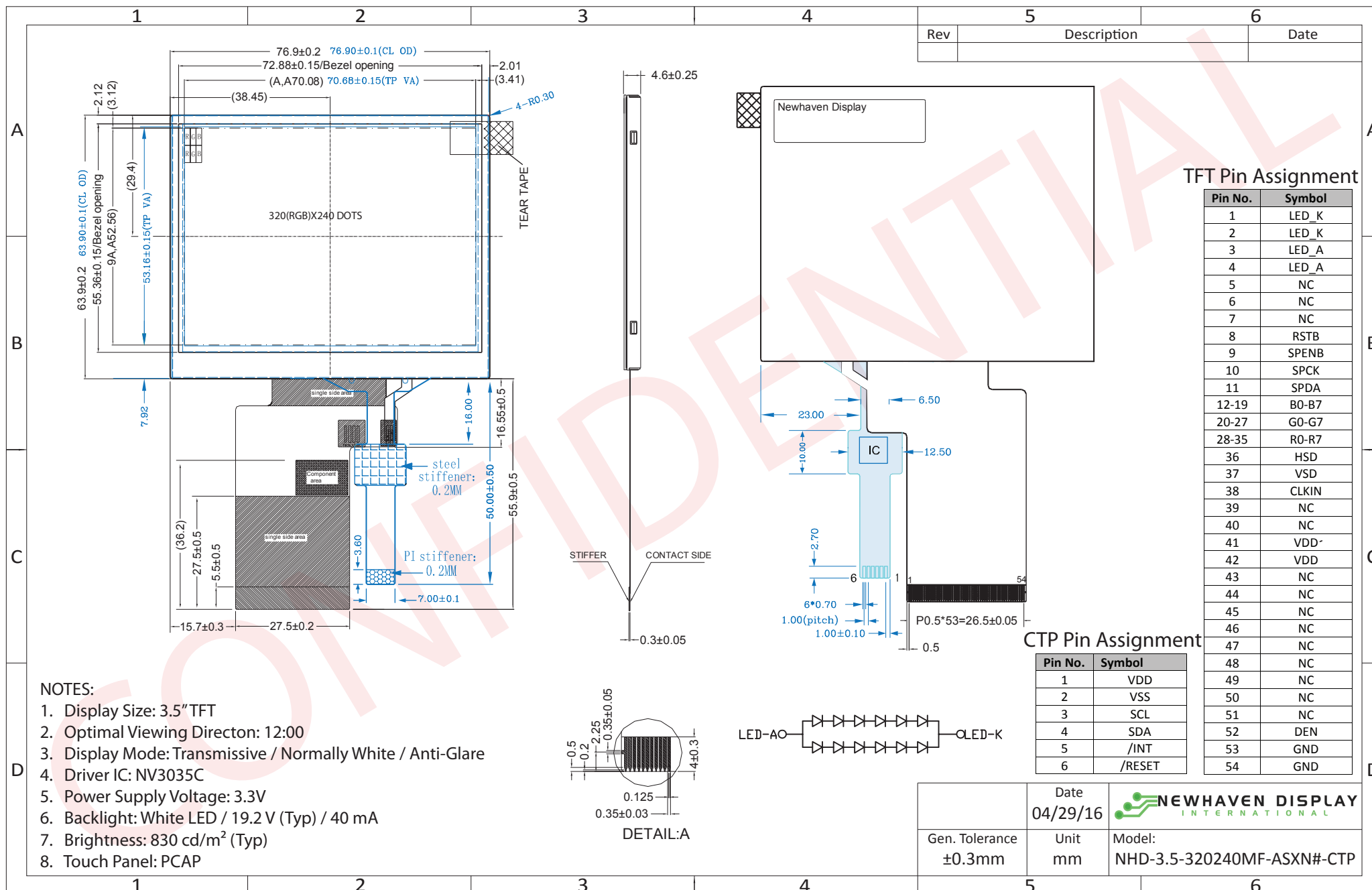

NOTES:

1. Display Size: 3.5" TFT
2. Optimal Viewing Directon: 12:00
3. Display Mode: Transmissive / Normally White / Anti-Glare
4. Driver IC: NV3035C
5. Power Supply Voltage: 3.3V
6. Backlight: White LED / 19.2 V (Typ) / 40 mA
7. Brightness: 830 cd/m² (Typ)
8. Touch Panel: PCAP

The drawing contained herein is the exclusive property of Newhaven Display International, Inc. and shall not be copied, reproduced, and/or disclosed in any format without permission.

Pin Description

TFT:

Pin No.	Symbol	External Connection	Function Description
1-2	LED_K	Power Supply	Backlight Cathode (Ground)
3-4	LED_A	Power Supply	Backlight Anode (40mA @ 19.2V)
5-7	NC	-	No Connect
8	RSTB	MPU	Active LOW Reset signal
9	SPENB	MPU	Active LOW Serial Chip Select signal
10	SPCK	MPU	Serial Clock signal
11	SPDA	MPU	Serial Data signal
12-19	B0-B7	MPU	Blue Data signals
20-27	G0-G7	MPU	Green Data signals
28-35	R0-R7	MPU	Red Data signals
36	HSD	MPU	Horizontal (Line) Sync signal
37	VSD	MPU	Vertical (Frame) Sync signal
38	CLKIN	MPU	Dot Clock signal
39-40	NC	-	No Connect
41-42	VDD	Power Supply	Supply Voltage for LCD and logic (3.3V)
43-51	NC	-	No Connect
52	DEN	-	Data Enable signal (No Connect)
53-54	GND	Power Supply	Ground

Recommended connector: 54pin, 0.5mm pitch, FFC connector. Molex P/N 51296-5494

Capacitive Touch Panel:

Pin No.	Symbol	External Connection	Function Description
1	VDD	Power Supply	Supply voltage for Logic (3.3V)
2	VSS	Power Supply	Ground
3	SCL	MPU	Serial I2C Clock (Requires pull-up resistor)
4	SDA	MPU	Serial I2C Data (Requires pull-up resistor)
5	/INT	MPU	Interrupt signal from touch panel module to host
6	/RESET	MPU	Active LOW Reset signal

Recommended connector: 6pin, 1.0mm pitch, FFC connector. Molex P/N 52271-0679

Driver/Controller Information

TFT:

Built-in NV3035C driver. No controller.

Please download specification at http://www.newhavendisplay.com/app_notes/NV3035C.pdf

Note: To achieve optimum VCOM and VGL settings, the SPI interface may be used to set the following registers:

ROEh = 6Bh

ROFh = 24h

Capacitive Touch Panel:

Built-in FocalTech FT5216 Capacitive Touch Controller.

Please download specification at http://www.newhavendisplay.com/app_notes/FT5x16.pdf

Electrical Characteristics

TFT:

Item	Symbol	Condition	Min.	Typ.	Max.	Unit
Operating Temperature Range	T _{OP}	Absolute Max	-20	-	+70	°C
Storage Temperature Range	T _{ST}	Absolute Max	-30	-	+80	°C
Supply Voltage	V _{DD}	-	3.0	3.3	3.6	V
Supply Current	I _{DD}	V _{DD} =3.3V	5	10	15	mA
"H" Level input	V _{IH}	-	0.8 * V _{DD}	-	V _{DD}	V
"L" Level input	V _{IL}	-	V _{SS}	-	0.2 * V _{DD}	V
"H" Level output	V _{OH}	-	V _{DD} - 0.4	-	V _{DD}	V
"L" Level output	V _{OL}	-	V _{SS}	-	V _{SS} + 0.4	V
Backlight Supply Voltage	V _{LED}	-	-	19.2	-	V
Backlight Supply Current	I _{LED}	V _{LED} =19.2V	30	40	50	mA
Backlight Lifetime*	-	I _{LED} = 40 mA T _{OP} = 25° C	20,000	50,000	-	Hrs.

*Backlight lifetime is rated as Hours until **half-brightness**, under normal operating conditions.

Capacitive Touch Panel:

Item	Symbol	Condition	Min.	Typ.	Max.	Unit
Operating Temperature Range	T _{OP}	Absolute Max	-20	-	+70	°C
Storage Temperature Range	T _{ST}	Absolute Max	-30	-	+80	°C
Supply Voltage	V _{DD}	-	2.8	3.3	3.6	V
Supply Current – Operating	I _{DD}	V _{DD} =3.3V	-	6.0	-	mA
Supply Current – Hibernate	I _{DD}	V _{DD} =3.3V	-	1.0	-	uA
"H" Level input	V _{IH}	-	0.7*V _{DD}	-	V _{DD}	V
"L" Level input	V _{IL}	-	V _{SS}	-	0.3*V _{DD}	V
"H" Level output	V _{OH}	-	0.7*V _{DD}	-	V _{DD}	V
"L" Level output	V _{OL}	-	V _{SS}	-	0.3*V _{DD}	V

Optical Characteristics

Item	Symbol	Condition	Min.	Typ.	Max.	Unit	
Optimal Viewing Angles	Top	CR ≥ 10	-	60	-	°	
	Bottom		-	40	-	°	
	Left		-	60	-	°	
	Right		-	60	-	°	
Contrast Ratio	CR	-	200	350	-	-	
Luminance	L _V	I _{LED} = 40 mA	660	830	-	cd/m ²	
Response Time	Rise	T _{OP} = 25°C	-	25	40	ms	
	Fall		-	25	40	ms	
Chromaticity	Red	X _R	-	0.547	0.597	0.647	-
		Y _R	-	0.283	0.333	0.383	-
	Green	X _G	-	0.274	0.324	0.374	-
		Y _G	-	0.574	0.624	0.674	-
	Blue	X _B	-	0.096	0.146	0.196	-
		Y _B	-	0.072	0.122	0.172	-
White	X _W	-	0.247	0.297	0.347	-	
	Y _W	-	0.315	0.365	0.415	-	

Capacitive Touch Panel Material Characteristics:

Property	Requirement	Unit
IC	FT5216GM7	-
ITO Glass thickness	0.55	mm
Surface Hardness	≥6	H
Light transmission	83% ± 5%	-
Operating Humidity	20~90	RH
Storage Humidity	20~90	RH

Capacitive Touch Panel Registers

Address	Name	B7	B6	B5	B4	B3	B2	B1	B0	Access	
00h	DEVICE_MODE	Device Mode [2..0]									R/W
01h	GEST_ID	Gesture ID [7..0]									R
02h	TD_STATUS							Touch Points [3..0]			R
03h	TOUCH1_XH	Event Flag			1st Touch X Position MSB [11..8]						R
04h	TOUCH1_XL	1st Touch X Position LSB [7..0]									R
05h	TOUCH1_YH	Touch ID [3..0]			1st Touch Y Position MSB [11..8]						R
06h	TOUCH1_YL	1st Touch Y Position LSB [7..0]									R
07h											R
08h											R
09h	TOUCH2_XH	Event Flag			2nd Touch X Position MSB [11..8]						R
0Ah	TOUCH2_XL	2nd Touch X Position LSB [7..0]									R
0Bh	TOUCH2_YH	Touch ID [3..0]			2nd Touch Y Position MSB [11..8]						R
0Ch	TOUCH2_YL	2nd Touch Y Position LSB [7..0]									R
0Dh											R
0Eh											R
0Fh	TOUCH3_XH	Event Flag			3rd Touch X Position MSB [11..8]						R
10h	TOUCH3_XL	3rd Touch X Position LSB [7..0]									R
11h	TOUCH3_YH	Touch ID [3..0]			3rd Touch Y Position MSB [11..8]						R
12h	TOUCH3_YL	3rd Touch Y Position LSB [7..0]									R
13h											R
14h											R
15h	TOUCH4_XH	Event Flag			4th Touch X Position MSB [11..8]						R
16h	TOUCH4_XL	4th Touch X Position LSB [7..0]									R
17h	TOUCH4_YH	Touch ID [3..0]			4th Touch Y Position MSB [11..8]						R
18h	TOUCH4_YL	4th Touch Y Position LSB [7..0]									R
19h											R
1Ah											R
1Bh	TOUCH5_XH	Event Flag			5th Touch X Position MSB [11..8]						R
1Ch	TOUCH5_XL	5th Touch X Position LSB [7..0]									R
1Dh	TOUCH5_YH	Touch ID [3..0]			5th Touch Y Position MSB [11..8]						R
1Eh	TOUCH5_YL	5th Touch Y Position LSB [7..0]									R
1Fh											R

Address	Name	B7	B6	B5	B4	B3	B2	B1	B0	Access	
80h	ID_G_THGROUP	valid touching detect threshold								R/W	
81h	ID_G_THPEAK	valid touching peak detect threshold								R/W	
82h	ID_G_THCAL	the threshold when calculating the focus of touching								R/W	
83h	ID_G_THWATER	the threshold when there is surface water								R/W	
84h	ID_G_TEMP	the threshold of temperature compensation								R/W	
85h	ID_G_THDIFF	the threshold whether the coordinate is different from original								R/W	
86h	ID_G_CTRL						Power Control Mode [1..0]				R/W
87h	ID_G_TIME_ENTER_MONITOR	the timer for entering monitor status								R/W	
88h	ID_G_PERIODACTIVE						Period Active [3..0]				R/W
89h	ID_G_PERIODMONITOR	the timer of entering idle when in monitor status								R/W	
A0h	ID_G_AUTO_CLB_MODE	auto calibration mode								R/W	
A1h	ID_G_LIB_VERSION_H	Firmware Library Version H byte								R	
A2h	ID_G_LIB_VERSION_L	Firmware Library Version L byte								R	
A3h	ID_G_CIPHER	Chip vendor ID								R	
A4h	ID_G_MODE	the interrupt status to host								R	
A5h	ID_G_PMODE	Power Consume Mode									
A6h	ID_G_FIRMID	Firmware ID								R	
A7h	ID_G_STATE	Running State									
A8h	ID_G_FT5201ID	CTPM Vendor ID								R	
A9h	ID_G_ERR	Error Code								R	
AAh	ID_G_CLB	Configure TP module during calibration in Test Mode								R/W	
FEh	LOG_MSG_CNT	The log MSG count								R	
FFh	LOG_CUR_CHA	Current character of log message								R	

NOTE: Registers 80h – AFh have been configured for optimum settings and do not need to be modified.

Register No	Register Name	Bits	Value	Description
00h	Device Mode	[2:0]	000b 100b 001b	Normal Operating Mode Test Mode - read raw data (reserved) System Information Mode (reserved)
01h	Gesture ID	[7:0]	48h 49h 00h	Zoom In Zoom Out No Gesture
02h	Touch Points	[3:0]	000b 001b 010b 011b 100b 101b	0 touch points detected 1 touch point detected 2 touch points detected 3 touch points detected 4 touch points detected 5 touch points detected
03h	Touch 1 Event Flag	[7:6]	00b 01b 10b 11b	Put Down Put Up Contact Reserved
03h	TOUCH1_XH	[3:0]	0h - 1h	Upper 4 bits of X touch coordinate
04h	TOUCH1_XL	[7:0]	00h - FFh	Lower 8 bits of X touch coordinate
05h	TOUCH1_YH	[3:0]	0h - 1h	Upper 4 bits of Y touch coordinate
06h	TOUCH1_YL	[7:0]	00h - FFh	Lower 8 bits of Y touch coordinate
09h	Touch 2 Event Flag	[7:6]	00b 01b 10b 11b	Put Down Put Up Contact Reserved
09h	TOUCH2_XH	[3:0]	0h - 1h	Upper 4 bits of X touch coordinate
0Ah	TOUCH2_XL	[7:0]	00h - FFh	Lower 8 bits of X touch coordinate
0Bh	TOUCH2_YH	[3:0]	0h - 1h	Upper 4 bits of Y touch coordinate
0Ch	TOUCH2_YL	[7:0]	00h - FFh	Lower 8 bits of Y touch coordinate
0Fh	Touch 3 Event Flag	[7:6]	00b 01b 10b 11b	Put Down Put Up Contact Reserved
0Fh	TOUCH3_XH	[3:0]	0h - 1h	Upper 4 bits of X touch coordinate
10h	TOUCH3_XL	[7:0]	00h - FFh	Lower 8 bits of X touch coordinate
11h	TOUCH3_YH	[3:0]	0h - 1h	Upper 4 bits of Y touch coordinate
12h	TOUCH3_YL	[7:0]	00h - FFh	Lower 8 bits of Y touch coordinate
15h	Touch 4 Event Flag	[7:6]	00b 01b 10b 11b	Put Down Put Up Contact Reserved
15h	TOUCH4_XH	[3:0]	0h - 1h	Upper 4 bits of X touch coordinate
16h	TOUCH4_XL	[7:0]	00h - FFh	Lower 8 bits of X touch coordinate
17h	TOUCH4_YH	[3:0]	0h - 1h	Upper 4 bits of Y touch coordinate
18h	TOUCH4_YL	[7:0]	00h - FFh	Lower 8 bits of Y touch coordinate

Register No	Register Name	Bits	Value	Description
1Bh	Touch 5 Event Flag	[7:6]	00b 01b 10b 11b	Put Down Put Up Contact Reserved
1Bh	TOUCH5_XH	[3:0]	0h - 1h	Upper 4 bits of X touch coordinate
1Ch	TOUCH5_XL	[7:0]	00h - FFh	Lower 8 bits of X touch coordinate
1Dh	TOUCH5_YH	[3:0]	0h - 1h	Upper 4 bits of Y touch coordinate
1Eh	TOUCH5_YL	[7:0]	00h - FFh	Lower 8 bits of Y touch coordinate
80h	ID_G_THGROUP	[7:0]	00h - FFh	Valid touching detect threshold Recommended: 46h Actual value will be 4 times register's value
81h	ID_G_THPEAK	[7:0]	00h - FFh	valid touching peak detect threshold Recommended: 3Ch
82h	ID_G_THCAL	[7:0]	00h - FFh	Touch focus threshold Recommended: 1Dh
83h	ID_G_THWATER	[7:0]	00h - FFh	threshold when there is surface water Recommended: D3h
84h	ID_G_THTEMP	[7:0]	00h - FFh	threshold of temperature compensation Recommended: EBh
85h	ID_G_THDIFF	[7:0]	00h - FFh	Touch difference threshold Recommended: A0h Actual value is 32 times the register's value
86h	ID_G_CTRL	[1:0]	00h 01h	Power Control Mode: Not Auto Jump Power Control Mode: Auto Jump
87h	ID_G_TIME_ENTER_MONITOR	[7:0]	00h-FFh	Delay to enter 'Monitor' status (s) Recommended: C8h
88h	ID_G_PERIODACTIVE	[3:0]	3h-Eh	Period of 'Active' status (ms) Recommended: 6h
89h	ID_G_PERIODMONITOR	[7:0]	1Eh-FFh	Timer to enter 'idle' when in 'Monitor' (ms) Recommended: 28h
A0h	ID_G_AUTO_CLB_MODE	[7:0]	00h FFh	Auto calibration mode: Enable auto calibration Auto calibration mode: Disable auto calibration
A1h	ID_G_LIB_VERSION_H	[7:0]	30h	Firmware Library Version H byte
A2h	ID_G_LIB_VERSION_L	[7:0]	01h	Firmware Library Version L byte
A3h	ID_G_CIPHER	[7:0]	0Ah	Chip vendor ID
A4h	ID_G_MODE	[0:0]	00h 01h	Interrupt status: Enable interrupt to host Interrupt status: Disable interrupt to host
A5h	ID_G_PMODE	[1:0]	00h 01h 03h	'Active' Mode 'Monitor' Mode 'Hibernate' Mode
A6h	ID_G_FIRMID	[7:0]	14h	Firmware ID
A7h	ID_G_STATE	[7:0]	00h 01h 02h 03h 04h	Running State: Configure Running State: Work Running State: Calibration Running State: Factory Running State: Auto-calibration
A8h	ID_G_FT5201ID	[7:0]	79h	CTPM Vendor's Chip ID
A9h	ID_G_ERR	[7:0]	00h 03h 05h 1Ah	Error Code: OK Error Code: Chip register writing inconsistent with reading Error Code: Chip start fail Error Code: Calibration match fail

Timing Characteristics – TFT Display

Parameter	Symbol	Min.	Typ.	Max.	Unit	Conditions
System Operation Timing						
VDD power source slew time	T _{POR}			1000	us	From 0V to 90% VDD
RSTB active pulse width	T _{RSTB}	40			us	VDD=3.3V
Input Output Timing						
CLKIN clock time	T _{clk}	-		35.7	ns	Please refer to timing table(P25)
HSD to CLKIN	T _{hc}	-	-	1	CLKIN	
HSD width	T _{hwh}	1	-	-	CLKIN	
VSD width	T _{vwh}	1	-	-	Th	
HSD period time	T _h	60	63.56	67	us	
VSD setup time	T _{vst}	12	-	-	ns	
VSD hold time	T _{vhd}	12	-	-	ns	
HSD setup time	T _{hst}	12	-	-	ns	
HSD hold time	T _{hhd}	12	-	-	ns	
Data set-up time	T _{dsu}	12	-	-	ns	DIN[23:0] to CLKIN
Data hold time	T _{dhd}	12	-	-	ns	DIN[23:0] to CLKIN
DEN setup time	T _{esd}	12	-	-	ns	DEN to CLKIN
Time that VSD to 1 st line data input	T _{vs}	2	13	127	Th	@CIR601/8bit RGB HV mode Control by HDLY[6:0] setting T _{vs} =HDLY[6:0]
Time that CCIR_V to 1 st line data input	T _{vs}	12	20	28	Th	@CCIR656 NTSC mode Control by HDLY[6:0] setting T _{vs} =HDLY[6:0]
Time that CCIR_V to 1 st line data input	T _{vs}	17	25	33	Th	@CCIR656 PAL mode Control by HDLY[6:0] setting T _{vs} =HDLY[6:0]
Time that VSD to 1 st line data input	T _{vs}	2	13	127	Th	@24bit RGB HV mode Control by HDLY[6:0] setting T _{vs} =HDLY[6:0]
Source output stable time 1	T _{st}	-	25	30	us	96% final, CL=30pF, RL=2K
Gate output stable time	T _{gst}	-	500	1000	ns	96% final, CL=40pF
VCOMOUT output stable time	T _{est}	-	4	8	us	96% final, CL=33nF, RL=100ohm
3-wire serial communication AC timing						
Serial clock	T _{spck}	320	-	-	ns	
SPCK pulse duty	T _{scdut}	40	50	60	%	T _{ckh} /T _{spck}
Serial data setup time	T _{isu}	120	-	-	ns	
Serial data hold time	T _{ihd}	120	-	-	ns	
Serial clock high/low	T _{ssw}	120	-	-	ns	
Chip select distinguish	T _{cd}	1	-	-	us	
SPENA to VSD	T _{cv}	1	-	-	us	
SPENB input setup time	T _{eck}	150	-	-	Ns	
SPENB input hold time	T _{cke}	150	-	-	ns	

Parameter	Symbol	Min.	Typ.	Max.	Unit	Conditions
CLKIN frequency	F _{clk}	6.1	6.4	8.0	MHz	VDD=3.0~3.6V
CLKIN cycle time	T _{clk}	125	156	164	ns	
CLKIN pulse duty	T _{cwh}	40	50	60	%	T _{clk}
Time that HSD to 1 st data input(NTSC)	T _{hs}	40	70	255	CLKIN	DDLY=70,Offset=0(fixed)

Input Data Format

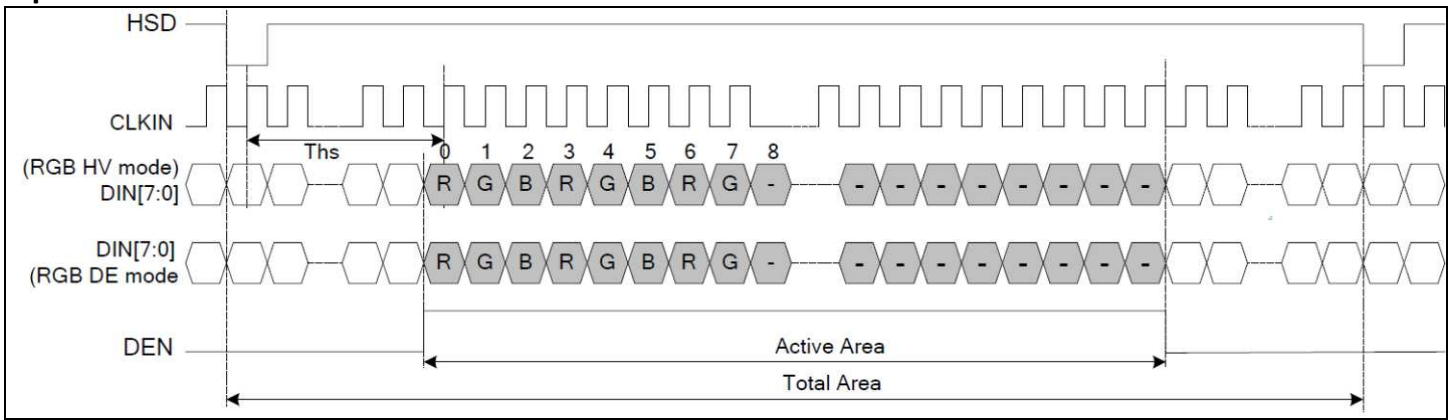

Clock and Data Input Timing Diagram

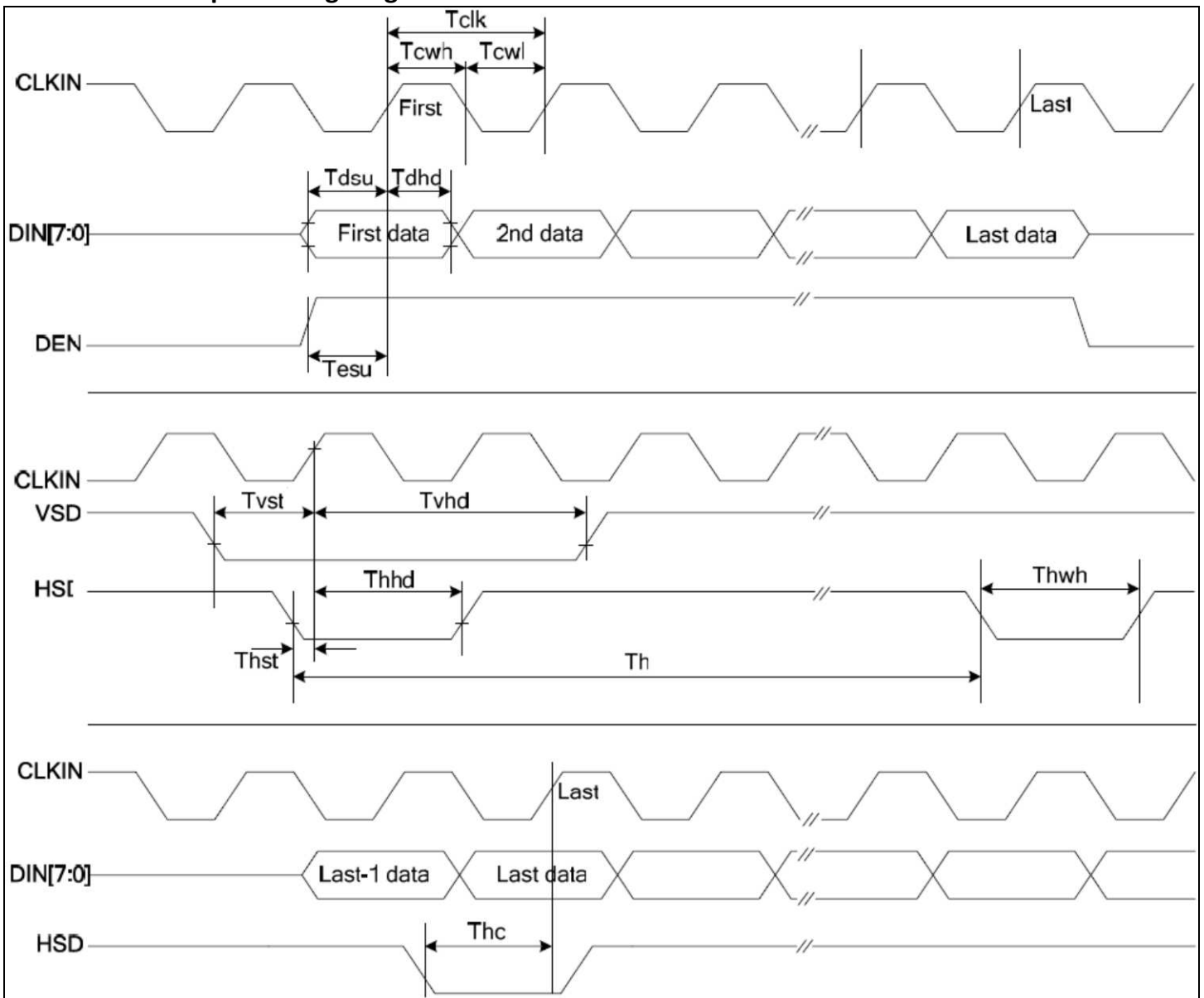

3-wire Timing Diagram

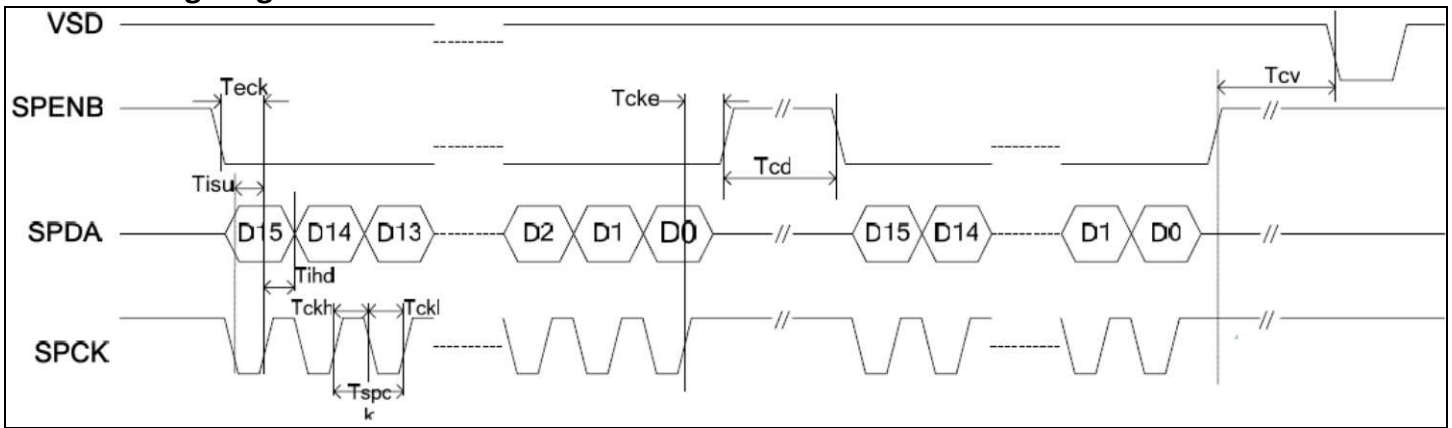

Input Data Timing

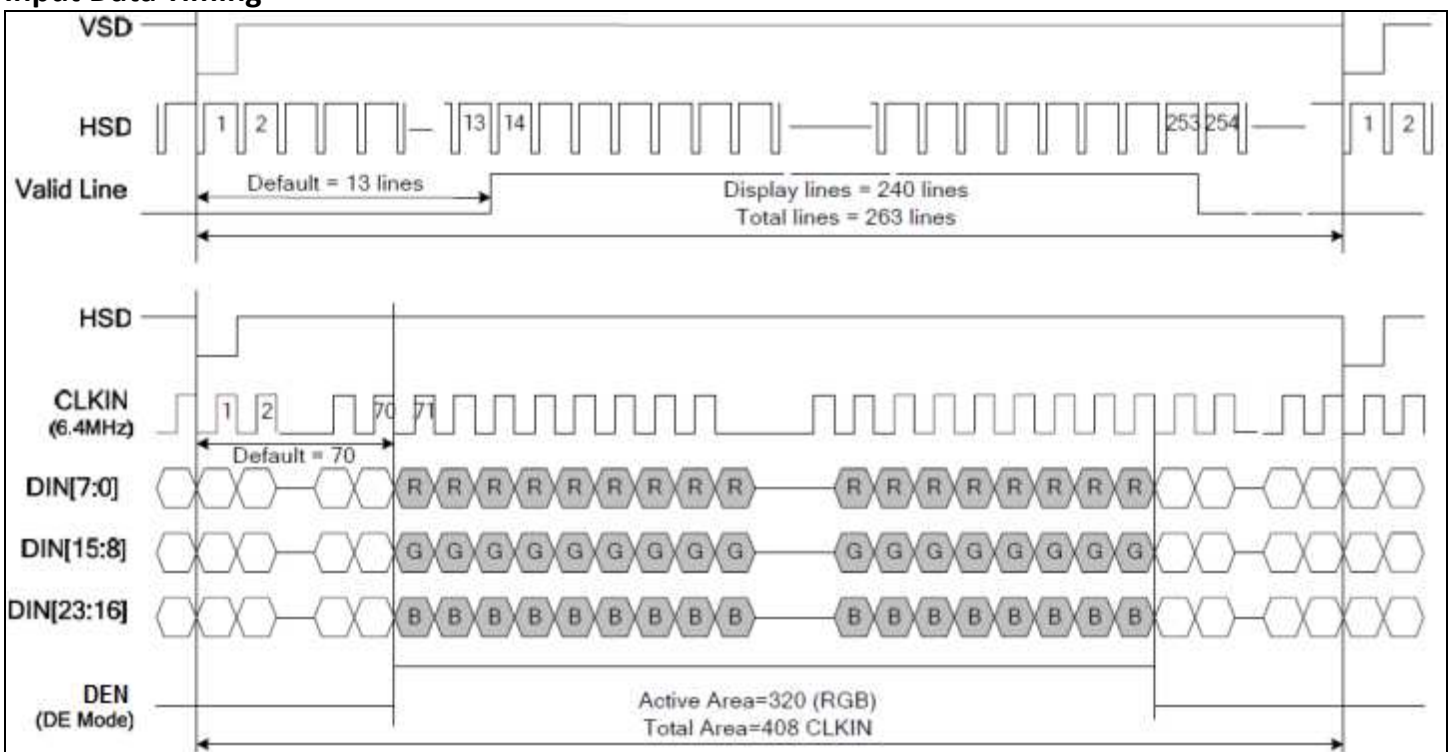

Timing Characteristics – Capacitive Touch Panel

Data Transfer Format

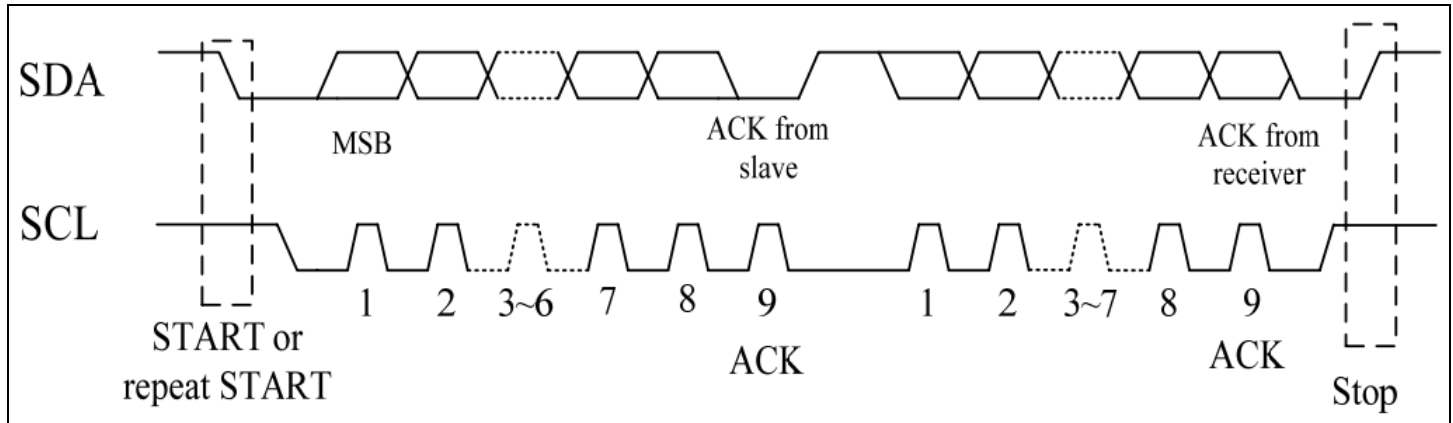

Parameter	Unit	Min	Max
SCL frequency	KHz	0	400
Bus free time between a STOP and START condition	us	4.7	\
Hold time (repeated) START condition	us	4.0	\
Data setup time	ns	250	\
Setup time for a repeated START condition	us	4.7	\
Setup Time for STOP condition	us	4.0	\

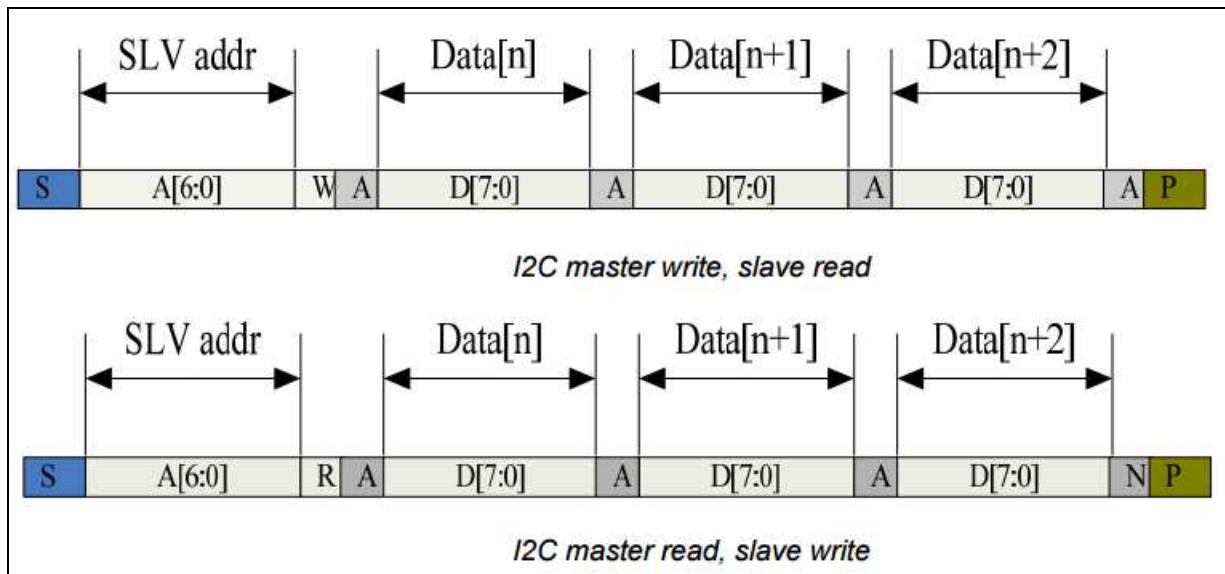

Power ON Sequence

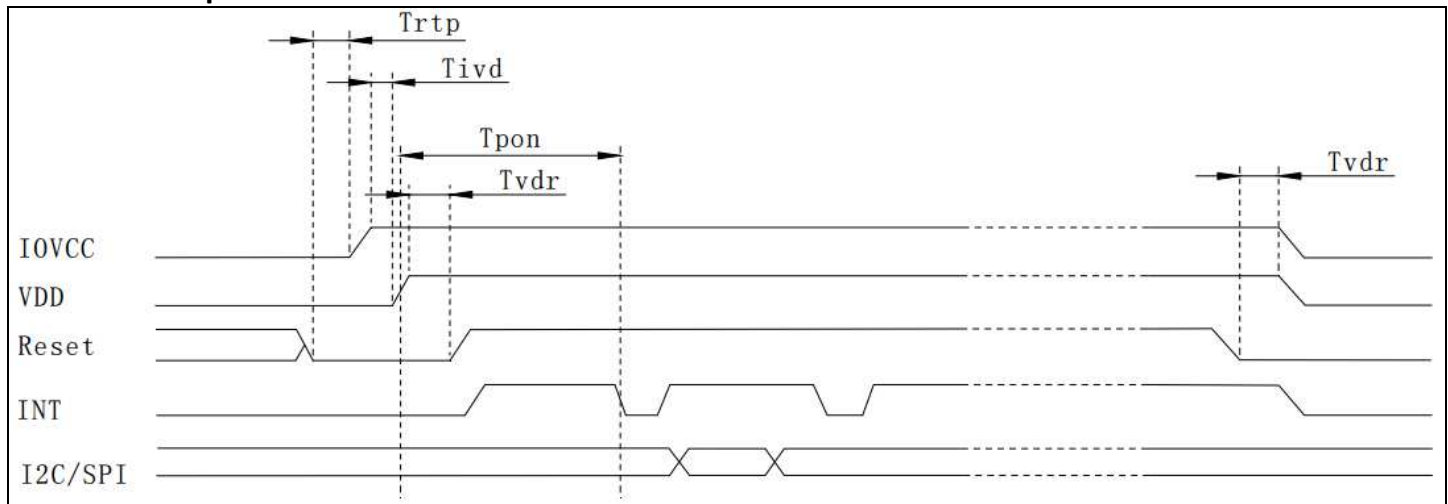

Reset Sequence

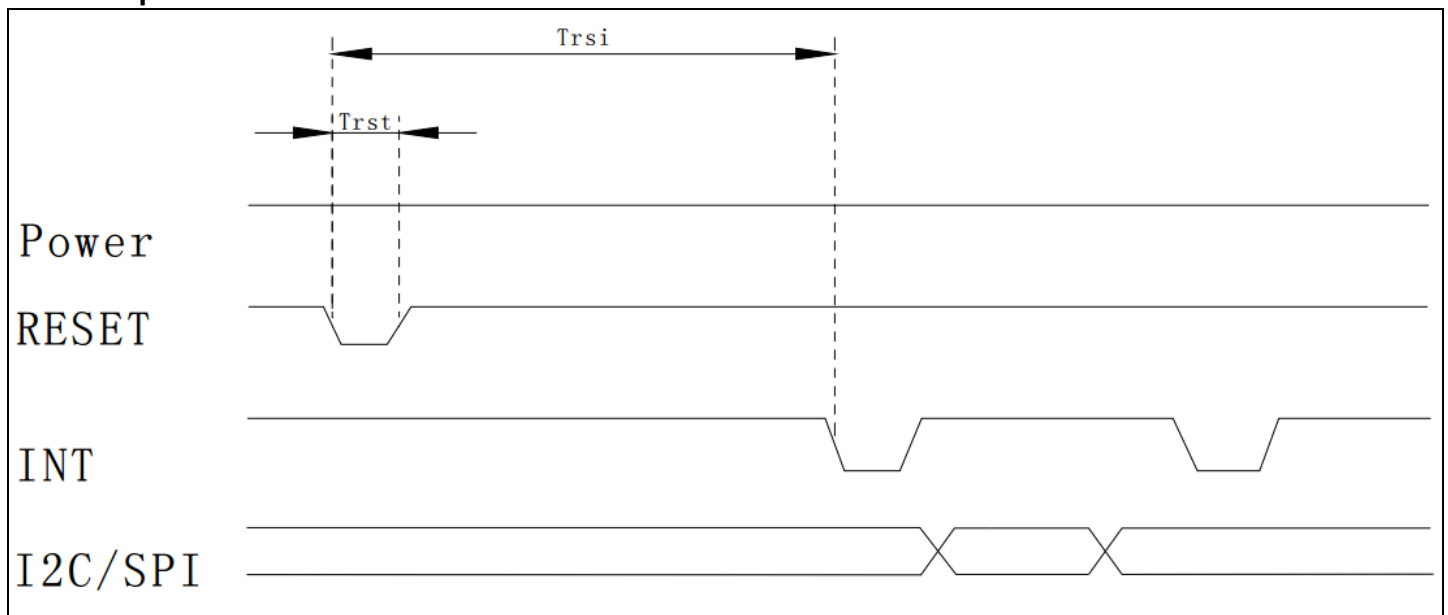

Parameter	Description	Min	Max	Units
Tris	Rise time from 0.1VDD to 0.9VDD	--	5	ms
Trtp	Time of resetting to be low before powering on	100	--	μ s
Tivd	Delay time of VDD powering on after IOVCC powering on	10	--	μ s
Tpon	Time of starting to report point after powering on	200	--	ms
Tvdr	Reset time after VDD powering on	1	--	ms
Trsi	Time of starting to report point after resetting	200	--	ms
Trst	Reset time	1	--	ms

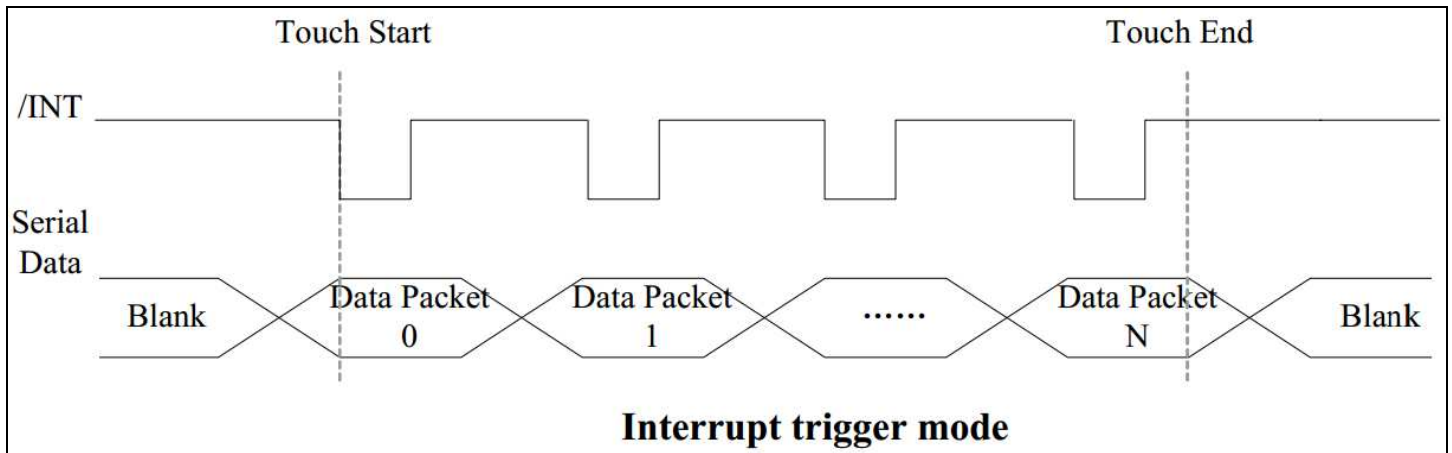

Sample code to read touch data:

```

i2c_start();
i2c_tx(0x70);           //Slave Address (Write)
i2c_tx(0x00);         //Start reading address
i2c_stop();

i2c_start();
i2c_tx(0x71);         //Slave Address (Read)
for(i=0x00;i<0x1F;i++)
{touchdata_buffer[i] = i2c_rx(1);}
i2c_stop();

```

Sample code to overwrite default register values:

```

i2c_start();
i2c_tx(0x70);           //Slave Address (Write)
i2c_tx(0xA4);         //ID_G_Mode
i2c_tx(0x01);         //Disable interrupt status to host
i2c_stop();

```

Quality Information

Test Item	Content of Test	Test Condition	Note
High Temperature storage	Endurance test applying the high storage temperature for a long time.	+70°C , 240hrs	2
Low Temperature storage	Endurance test applying the low storage temperature for a long time.	-30°C , 240hrs	1,2
High Temperature Operation	Endurance test applying the electric stress (voltage & current) and the high thermal stress for a long time.	+60°C , 240hrs	2
Low Temperature Operation	Endurance test applying the electric stress (voltage & current) and the low thermal stress for a long time.	-20°C , 240hrs	1,2
High Temperature / Humidity Operation	Endurance test applying the electric stress (voltage & current) and the high thermal with high humidity stress for a long time.	+60°C , 90% RH , 160hrs	1,2
Thermal Shock resistance	Endurance test applying the electric stress (voltage & current) during a cycle of low and high thermal stress.	-30°C,30min -> 25°C,5min -> 80°C,30min = 1 cycle 100 cycles	
Vibration test	Endurance test applying vibration to simulate transportation and use.	10-55Hz , 15mm amplitude. 60 sec in each of 3 directions X,Y,Z For 15 minutes	3
Static electricity test	Endurance test applying electric static discharge.	VS=4KV, RS=330kΩ, CS=150pF Five times	

Note 1: No condensation to be observed.

Note 2: Conducted after 4 hours of storage at 25°C, 0%RH.

Note 3: Test performed on product itself, not inside a container.

Precautions for using LCDs/LCMs

See Precautions at www.newhavendisplay.com/specs/precautions.pdf

Warranty Information and Terms & Conditions

http://www.newhavendisplay.com/index.php?main_page=terms