



Chipsmall Limited consists of a professional team with an average of over 10 year of expertise in the distribution of electronic components. Based in Hongkong, we have already established firm and mutual-benefit business relationships with customers from,Europe,America and south Asia,supplying obsolete and hard-to-find components to meet their specific needs.

With the principle of “Quality Parts,Customers Priority,Honest Operation,and Considerate Service”,our business mainly focus on the distribution of electronic components. Line cards we deal with include Microchip,ALPS,ROHM,Xilinx,Pulse,ON,Everlight and Freescale. Main products comprise IC,Modules,Potentiometer,IC Socket,Relay,Connector.Our parts cover such applications as commercial,industrial, and automotives areas.

We are looking forward to setting up business relationship with you and hope to provide you with the best service and solution. Let us make a better world for our industry!



Contact us

Tel: +86-755-8981 8866 Fax: +86-755-8427 6832

Email & Skype: info@chipsmall.com Web: www.chipsmall.com

Address: A1208, Overseas Decoration Building, #122 Zhenhua RD., Futian, Shenzhen, China



User's Guide

NHD-320240WG-**BOTMI-VZ** **LCM**

(Liquid Crystal Graphic Display Module)

For product support, contact

Newhaven Display International, LLC

2511 Technology Drive, #101

Elgin, IL 60123

Tel: (847) 844-8795 Fax: (847) 844-8796

September 29, 2008

Contents

1. Module classification information
2. Precautions in Use of LCM
3. General Specification
4. Absolute Maximum Ratings
5. Electrical Characteristics
6. Optical Characteristics
7. Interface Description
8. Contour Drawing & Block Diagram
9. Quality Assurance
10. Reliability
11. Backlight Information

1. Module Classification Information

NHD 320240 W G — **BO T M I - VZ**

① ② ③ ④ ⑤ ⑥ ⑦ ⑧ 9

- ① Brand : Newhaven Display
- ② Display Font : 320 x 240 Dots
- ③ Factory Line: W
- ④ Display Type : H→Character Type, G→Graphic Type, C→ Color
- ⑤ Model / Serial number = **BO Built-in RA8835 controller (Epson 1335 equiv.)**
- ⑥ Backlight Type : N→Without backlight
- | | |
|---------------------|----------------------|
| B→EL, Blue green | A→LED, Amber |
| D→EL, Green | R→LED, Red |
| W→EL, White | O→LED, Orange |
| F→CCFL, White | G→LED, Green |
| Y→LED, Yellow Green | T →LED, White |
- ⑦ LCD Mode : B→TN Positive, Gray T→FSTN Negative
- | | |
|------------------------------|-----------------|
| N→TN Negative, | C→STN Color |
| G→STN Positive, Gray | F→FSTN Positive |
| Y→STN Positive, Yellow Green | |
| M →STN Negative, Blue | |
- ⑧ LCD Polarize Type/ A→Reflective, N.T, 6:00 H→Transflective, W.T,6:00
- | | |
|--|------------------------------------|
| Temperature range/ D→Reflective, N.T, 12:00 K→Transflective, | |
| View direction G→Reflective, W. T, 6:00 W.T,12:00 | |
| J→Reflective, W. T, 12:00 | C→Transmissive, N.T,6:00 |
| B→Transflective, N.T,6:00 | F→Transmissive, N.T,12:00 |
| E→Transflective, N.T.12:00 | I →Transmissive, W. T, 6:00 |
| | L→Transmissive, W.T,12:00 |
- 9 Special Code **VZ** : Built-in Negative voltage

2. Precautions in Use of LCD Module

- (1) Avoid applying excessive shocks to the module or making any alterations or modifications to it.
- (2) Don't make extra holes on the printed circuit board, modify its shape or change the components of LCD Module.
- (3) Don't disassemble the LCM.
- (4) Don't operate it above the absolute maximum rating.
- (5) Don't drop, bend or twist LCM.
- (6) Soldering: only to the I/O terminals.
- (7) Storage: please storage in anti-static electricity container and clean environment.

3. General Specification:

NHD-320240WG-BOTMI-VZ

ITEM	STANDARD VALUE	UNIT
Number of dots	320x240	dots
Outline dimension	166.8(W) x 109.0(H) x 11.0max(T)	mm
View area	122.0(W) x 92.0(H)	mm
Active area	115.18(W) x 86.38(H)	mm
Dot size	0.34(W) x 0.34(H)	mm
Dot pitch	0.36(W) x 0.36(H)	mm
LCD type	STN- Blue , Negative, Transmissive	
View direction	6 o'clock	
Backlight	LED, White	

4. Absolute Maximum Ratings

ITEM	SYMBOL	MIN.	TYP.	MAX.	UNIT
Operating Temperature	T_{OP}	-20	—	+70	°C
Storage Temperature	T_{ST}	-30	—	+80	°C
Input Voltage	V_I	0	—	V_{DD}	V
Supply Voltage For Logic	V_{DD}	0	—	6.5	V
Supply Voltage For LCD	$V_{DD}-V_{EE}$	0	—	32	V

5. Electrical Characteristics

ITEM	SYMBOL	CONDITION	MIN.	TYP.	MAX.	UNIT
Logic Voltage	$V_{DD}-V_{SS}$	—	4.5	5.0	5.5	V
Supply Voltage For LCD	$V_{DD}-V_O$	$T_a=-20^{\circ}\text{C}$	—	—	26.0	V
		$T_a=25^{\circ}\text{C}$	—	24.0	—	V
		$T_a=+70^{\circ}\text{C}$	22.0	—	—	V
Input High Volt.	V_{IH}	—	$0.5V_{DD}$	—	V_{DD}	V
Input Low Volt.	V_{IL}	—	0	—	$0.2V_{DD}$	V
Output High Volt.	V_{OH}	—	2.4	—	—	V
Output Low Volt.	V_{OL}	—	—	—	0.4	V
Supply Current	I_{DD}	—	95.0	100.0	110.0	mA

6. Optical Characteristics

ITEM	SYMBAL	CONDITION	MIN	TYP	MAX	UNIT
View Angle	(V) θ	$CR \geq 2$	20	—	40	deg.
	(H) φ	$CR \geq 2$	-30	—	30	deg.
Contrast Ratio	CR	—	—	3	—	—
Response Time	T rise	—	—	150	200	ms
	T fall	—	—	150	200	ms

6.1 Definitions

View Angles

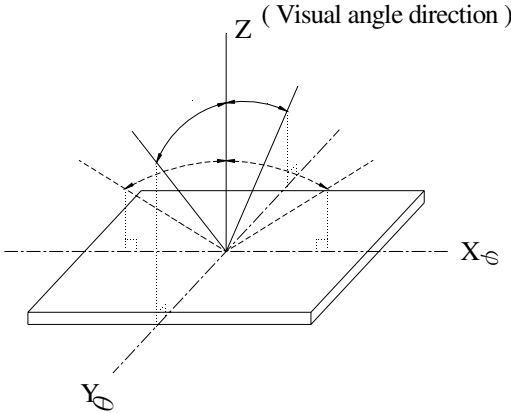

Contrast Ratio

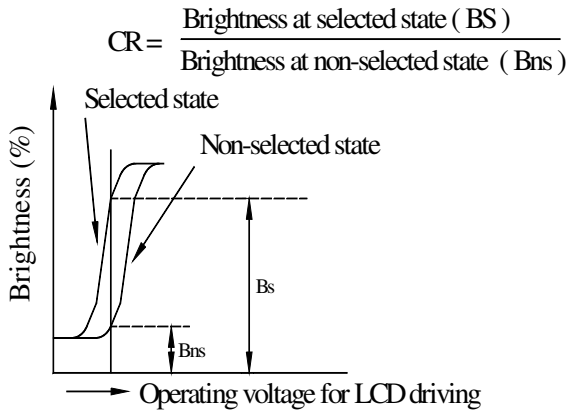

Response time

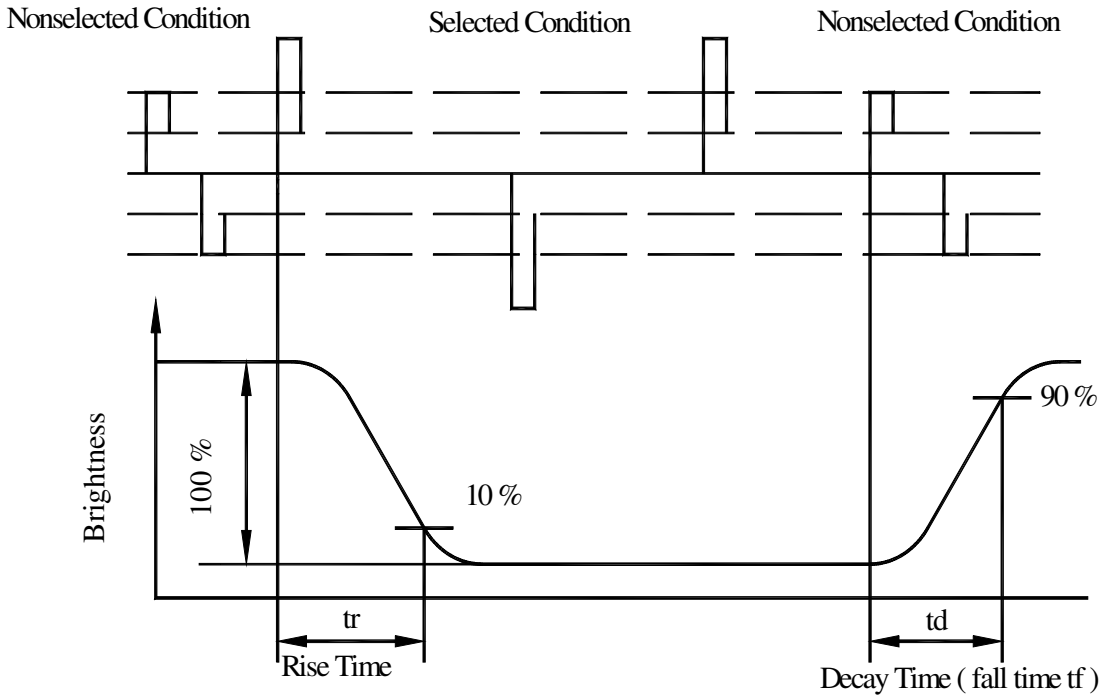

7. Interface Description

Pin No.	Symbol	Level	Description
1	V _{SS}	0V	Ground
2	V _{DD}	5.0V	Power supply for Logic
3	V _O	(Variable)	Driving voltage for LCD
4	A0	H/L	RD=L WR=H, A0=L :Data Read AO=H :Status read RD=H WR=L, A0=L :Data Write AO=H :Command write
5	$\overline{\text{WR}}$	H/L	8080 family: Write signal, 6800 family: R/W signal
6	$\overline{\text{RD}}$	H/L	8080 family: Read signal, 6800 family: Enable clock
7~14	DB0~DB7	H/L	Data bus
15	$\overline{\text{CS}}$	H/L	Chip select, Active L
16	$\overline{\text{RES}}$	H/L	Controller reset signal, Active L
17	V _{EE}	-25V	Negative voltage output (Optional)
18	SEL1		NC (6800 series MPU interface option) *Note1
19	FGND		NC (Frame Ground option)
20	NC		No connection

8. Contour Drawing & Block diagram

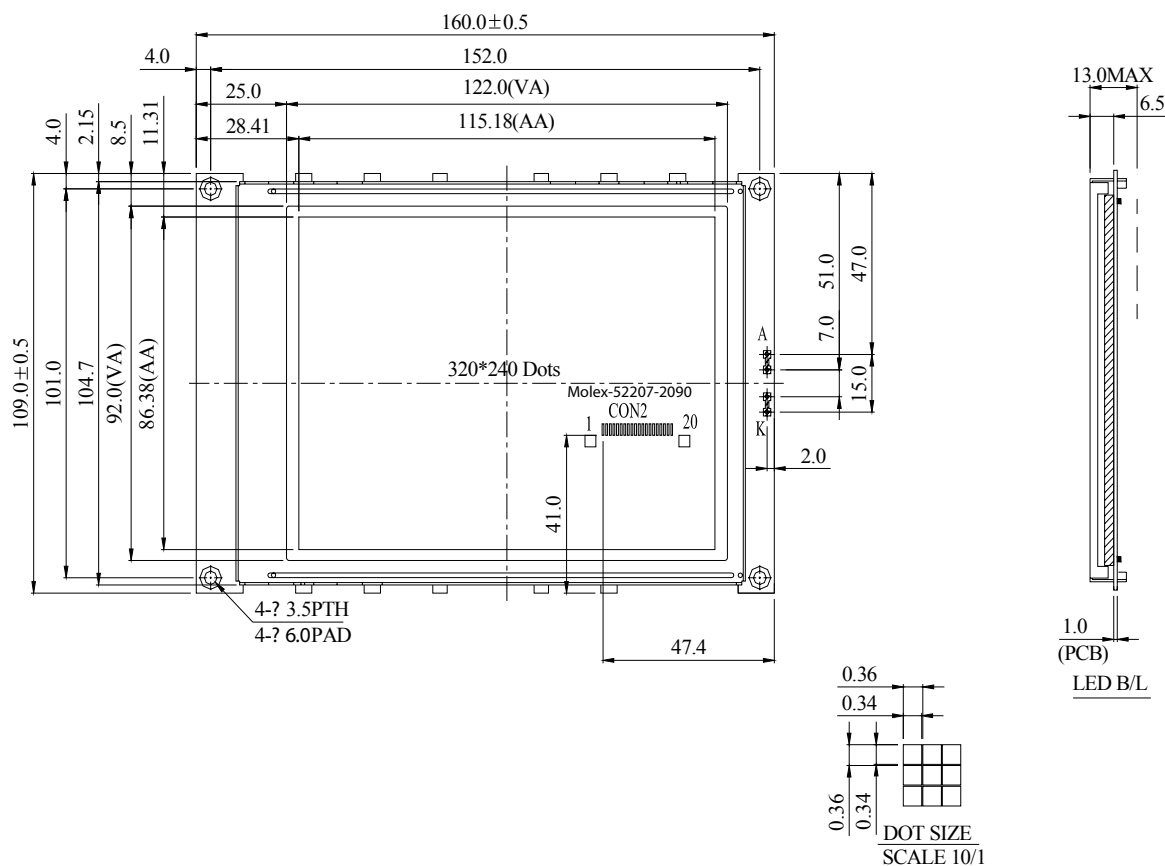

PIN NO.	SYMBOL
1	Vss
2	Vdd
3	Vo
4	A0
5	\overline{WR}
6	\overline{RD}
7	DB0
8	DB1
9	DB2
10	DB3
11	DB4
12	DB5
13	DB6
14	DB7
15	\overline{CS}
16	RES
17	Vee
18	SEL1
19	FGND
20	NC

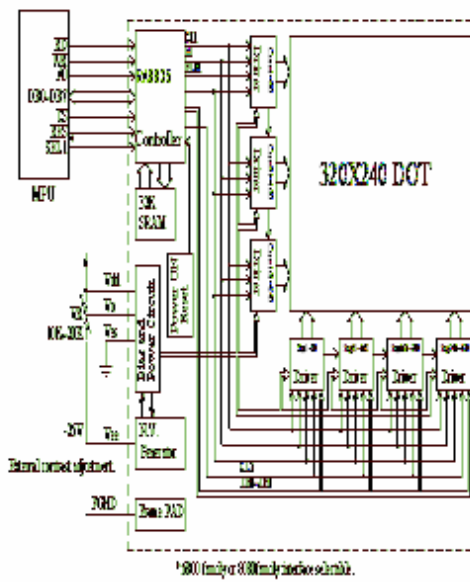
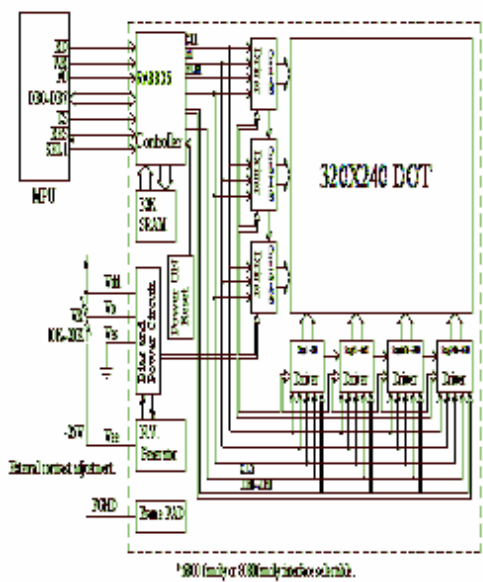

9. Quality Assurance

◆ Screen Cosmetic Criteria

No.	Defect	Judgement Criterion	Partition																				
1	Spots	<p>A) Clear</p> <table border="1"> <thead> <tr> <th>Size: d mm</th> <th>Acceptable Qty in active area</th> </tr> </thead> <tbody> <tr> <td>$d \leq 0.1$</td> <td>Disregard</td> </tr> <tr> <td>$0.1 < d \leq 0.2$</td> <td>6</td> </tr> <tr> <td>$0.2 < d \leq 0.3$</td> <td>2</td> </tr> <tr> <td>$0.3 < d$</td> <td>0</td> </tr> </tbody> </table> <p>Note: Including pin holes and defective dots which must be within one pixel size.</p> <p>B) Unclear</p> <table border="1"> <thead> <tr> <th>Size: d mm</th> <th>Acceptable Qty in active area</th> </tr> </thead> <tbody> <tr> <td>$d \leq 0.2$</td> <td>Disregard</td> </tr> <tr> <td>$0.2 < d \leq 0.5$</td> <td>6</td> </tr> <tr> <td>$0.5 < d \leq 0.7$</td> <td>2</td> </tr> <tr> <td>$0.7 < d$</td> <td>0</td> </tr> </tbody> </table>	Size: d mm	Acceptable Qty in active area	$d \leq 0.1$	Disregard	$0.1 < d \leq 0.2$	6	$0.2 < d \leq 0.3$	2	$0.3 < d$	0	Size: d mm	Acceptable Qty in active area	$d \leq 0.2$	Disregard	$0.2 < d \leq 0.5$	6	$0.5 < d \leq 0.7$	2	$0.7 < d$	0	Minor
Size: d mm	Acceptable Qty in active area																						
$d \leq 0.1$	Disregard																						
$0.1 < d \leq 0.2$	6																						
$0.2 < d \leq 0.3$	2																						
$0.3 < d$	0																						
Size: d mm	Acceptable Qty in active area																						
$d \leq 0.2$	Disregard																						
$0.2 < d \leq 0.5$	6																						
$0.5 < d \leq 0.7$	2																						
$0.7 < d$	0																						
2	Bubbles in Polarize	<table border="1"> <thead> <tr> <th>Size: d mm</th> <th>Acceptable Qty in active area</th> </tr> </thead> <tbody> <tr> <td>$d \leq 0.3$</td> <td>Disregard</td> </tr> <tr> <td>$0.3 < d \leq 1.0$</td> <td>3</td> </tr> <tr> <td>$1.0 < d \leq 1.5$</td> <td>1</td> </tr> <tr> <td>$1.5 < d$</td> <td>0</td> </tr> </tbody> </table>	Size: d mm	Acceptable Qty in active area	$d \leq 0.3$	Disregard	$0.3 < d \leq 1.0$	3	$1.0 < d \leq 1.5$	1	$1.5 < d$	0	Minor										
Size: d mm	Acceptable Qty in active area																						
$d \leq 0.3$	Disregard																						
$0.3 < d \leq 1.0$	3																						
$1.0 < d \leq 1.5$	1																						
$1.5 < d$	0																						
3	Scratch	In accordance with spots cosmetic criteria. When the light reflects on the panel surface, the scratches are not to be remarkable.	Minor																				
4	Allowable Density	Above defects should be separated more than 30mm each other.	Minor																				
5	Coloration	Not to be noticeable coloration in the viewing area of the LCD panels. Back-light type should be judged with back-light on state only.	Minor																				

10. RELIABILITY

Content of Reliability Test

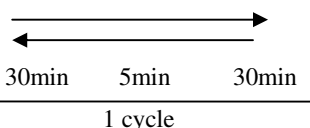
Environmental Test				
No.	Test Item	Content of Test	Test Condition	Applicable Standard
1	High Temperature storage	Endurance test applying the high storage temperature for a long time.	80°C 200hrs	—
2	Low Temperature storage	Endurance test applying the high storage temperature for a long time.	-30°C 200hrs	—
3	High Temperature Operation	Endurance test applying the electric stress (Voltage & Current) and the thermal stress to the element for a long time.	70°C 200hrs	—
4	Low Temperature Operation	Endurance test applying the electric stress under low temperature for a long time.	-20°C 200hrs	—
5	High Temperature/ Humidity Storage	Endurance test applying the high temperature and high humidity storage for a long time.	80°C, 90%RH 96hrs	—
6	High Temperature/ Humidity Operation	Endurance test applying the electric stress (Voltage & Current) and temperature / humidity stress to the element for a long time.	70°C, 90%RH 96hrs	—
7	Temperature Cycle	Endurance test applying the low and high temperature cycle. -30°C 25°C 80°C  30min 5min 30min 1 cycle	-30°C/80°C 10 cycles	—
Mechanical Test				
8	Vibration test	Endurance test applying the vibration during transportation and using.	Total fixed amplitude : 15mm Vibration Frequency : 10~15Hz One cycle 60 seconds to 3 directions of X,Y,Zfor Each 15 minutes	—
Others				
11	Static electricity test	Endurance test applying the electric stress to the terminal.	VS=800V,RS=1.5kΩ CS=100pF 1 time	—

***Supply voltage for logic system=5V. Supply voltage for LCD system =Operating voltage at 25°C

11. Backlight Information

(Ta=25°C)

PARAMETER	SYMBOL	MIN	TYP	MAX	UNIT	TEST CONDITION
Supply Current	I _{LED}	120	160	240	mA	V=3.5V
Supply Voltage	V	3.4	3.5	3.6	V	—
Reverse Voltage	V _R	—	—	10	V	—
Luminous Intensity	I _V	220	250	—	CD/M ²	I _{LED} =160mA
Life Time	—	—	50K	—	Hr.	I _{LED} =160mA
Color	WHITE					

Note: The LED of B/L is driven by current only, drive voltage is for reference only.

Drive voltage can make driving current under safety area (current between minimum and maximum).