



Chipsmall Limited consists of a professional team with an average of over 10 year of expertise in the distribution of electronic components. Based in Hongkong, we have already established firm and mutual-benefit business relationships with customers from,Europe,America and south Asia,supplying obsolete and hard-to-find components to meet their specific needs.

With the principle of “Quality Parts,Customers Priority,Honest Operation,and Considerate Service”,our business mainly focus on the distribution of electronic components. Line cards we deal with include Microchip,ALPS,ROHM,Xilinx,Pulse,ON,Everlight and Freescale. Main products comprise IC,Modules,Potentiometer,IC Socket,Relay,Connector.Our parts cover such applications as commercial,industrial, and automotives areas.

We are looking forward to setting up business relationship with you and hope to provide you with the best service and solution. Let us make a better world for our industry!



## Contact us

Tel: +86-755-8981 8866 Fax: +86-755-8427 6832

Email & Skype: info@chipsmall.com Web: www.chipsmall.com

Address: A1208, Overseas Decoration Building, #122 Zhenhua RD., Futian, Shenzhen, China



## User's Guide

# NHD-320240WG-BxFMI-VZ#

# LCM

(Liquid Crystal Display Graphic Module)

RoHS Compliant

<b>NHD-</b>	Newhaven Display
<b>320240-</b>	320 x 240 pixels
<b>WG-</b>	Display Type: Graphic
<b>B x-</b>	Model serial number: B, x: New IC rev.
<b>F-</b>	White CCFL B/L
<b>M-</b>	STN-(negative) Blue
<b>I-</b>	Transmissive, 6:00 View, Wide Temperature (-20 ~ +70c)
<b>VZ#-</b>	Negative voltage generator on board

---

For product support, contact

**Newhaven Display International**  
**2511 Technology Drive, #101**  
**Elgin, IL 60124**

Tel: (847) 844-8795 Fax: (847) 844-8796

March 12, 2009

# Contents

1. Module classification information
2. Precautions in Use of LCM
3. General Specification
4. Absolute Maximum Ratings
5. Electrical Characteristics
6. Optical Characteristics
7. Interface Description
8. Contour Drawing & Block Diagram
9. Timing Characteristics
10. Reliability
11. Backlight Information
12. Inspection specification

# 1. Module Classification Information

NHD    3 2 0 2 4 0    WG - Bx F M I - VZ#  
 ①                      ②                      ③    ④   ⑤ ⑥ ⑦                      ⑧

① Brand : NEWHAVEN DISPLAY INTERNATIONAL, LLC.

② Display Font : 320 \* 240 Dots

③ Display Type : H→Character Type, G→Graphic Type

④ Model serials number: **B**,    **x**: New IC rev.

⑤ Backlight Type :

N→Without backlight	A→LED, Amber
B→EL, Blue green	R→LED, Red
D→EL, Green	O→LED, Orange
W→EL, White	G→LED, Green
<b>F</b> →CCFL, White	T→LED, White
Y→LED, Yellow Green	S→LED, Bright White

⑥ LCD Mode :

B→TN Positive, Gray	T→FSTN Negative
N→TN Negative,	<b>M</b> →STN Negative, Blue
G→STN Positive, Gray	F→FSTN Positive
Y→STN Positive, Yellow Green	

⑦ LCD Polarizer Type/ Temperature range/ View direction

A→Reflective, N.T, 6:00	H→Transflective, W.T,6:00
D→Reflective, N.T, 12:00	K→Transflective, W.T,12:00
G→Reflective, W. T, 6:00	C→Transmissive, N.T,6:00
J→Reflective, W. T, 12:00	F→Transmissive, N.T,12:00
B→Transflective, N.T,6:00	<b>I</b> →Transmissive, W. T, 6:00
E→Transflective, N.T.12:00	L→Transmissive, W.T,12:00

⑧ Special Code    **VZ** : Negative voltage generator on board  
**#** : RoHS Compliant

## 2. Precautions in Use of LCD Module

- (1) Avoid applying excessive shock to the module or making any alterations or modifications to it.
- (2) Don't make extra holes on the printed circuit board, modify its shape or change the components of LCD Module.
- (3) Don't disassemble the LCM.
- (4) Don't operate it above the absolute maximum rating.
- (5) Don't drop, bend or twist LCM.
- (6) Soldering: only to the I/O terminals.
- (7) Storage: please store in anti-static electricity container and clean environment.

## 3. General Specification

**NHD-320240WG-BxFMI-VZ#**

ITEM	STANDARD VALUE	UNIT
Number of dots	320x240	dots
Outline dimension	160.0(W)x 109.0(H)x 13.0max(T)	mm
View area	122.0(W)x 92.0(H)	mm
Active area	115.18(W)x 86.38(H)	mm
Dot size	0.34(W)x 0.34(H)	mm
Dot pitch	0.36(W)x 0.36(H)	mm
LCD type	STN- (negative) BLUE	
View direction	6 o'clock	
Backlight	CCFL, White	

## 4. Absolute Maximum Ratings

ITEM	SYMBOL	MIN.	TYP.	MAX.	UNIT
Operating Temperature	$T_{OP}$	-20	-	+70	°C
Storage Temperature	$T_{ST}$	-30	-	+80	°C
Input Voltage	$V_I$	0	-	$V_{DD}$	V
Supply Voltage For Logic	$V_{DD}$	0	-	6.5	V
Supply Voltage For LCD	$V_{DD}-V_{EE}$	0	-	32	V

## 5. Electrical Characteristics

ITEM	SYMBOL	CONDITION	MIN.	TYP.	MAX.	UNIT
Logic Voltage	$V_{DD}-V_{SS}$	-	4.75	5.0	5.25	V
Supply Voltage For LCD	$V_{DD}-V_O$	$T_a=-20^{\circ}\text{C}$	-	-	26.1	V
		$T_a=25^{\circ}\text{C}$	-	23.8	-	V
		$T_a=+70^{\circ}\text{C}$	22.2	-	-	V
Input High Volt.	$V_{IH}$	-	$0.5V_{DD}$	-	$V_{DD}$	V
Input Low Volt.	$V_{IL}$	-	0	-	$0.2V_{DD}$	V
Output High Volt.	$V_{OH}$	-	$V_{DD}-0.4$	-	-	V
Output Low Volt.	$V_{OL}$	-	-	-	0.4	V
Supply Current	$I_{DD}$	-	65.0	75.0	85.0	mA

## 6. Optical Characteristics

ITEM	SYMBOL	CONDITION	MIN	TYP	MAX	UNIT
View Angle	$(V)\theta$	$CR \geq 2$	20	-	40	deg.
	$(H)\phi$	$CR \geq 2$	-30	-	30	deg.
Contrast Ratio	CR	-	-	3	-	-



ITEM	SYMBAL	CONDITION	MIN	TYP	MAX	UNIT
View Angle	(V) $\theta$	$CR \geq 2$	20	—	40	deg.
	(H) $\phi$	$CR \geq 2$	-30	—	30	deg.
Contrast Ratio	CR	—	—	3	—	—
Response Time	T rise	—	—	200	300	ms
	T fall	—	—	150	200	ms

## 6.1 Definitions

### ■ View Angles

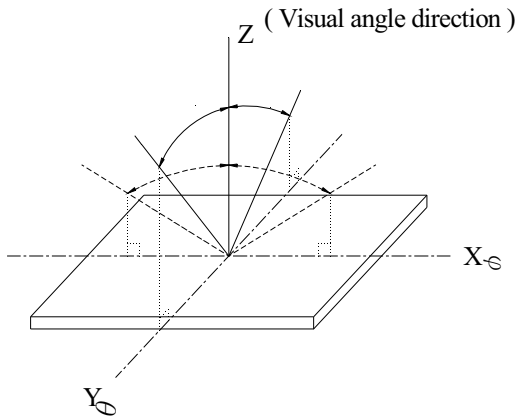

### ■ Contrast Ratio

$$CR = \frac{\text{Brightness at selected state (BS)}}{\text{Brightness at non-selected state (Bns)}}$$

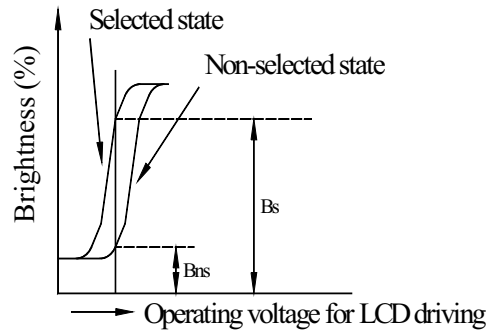

### ■ Response time

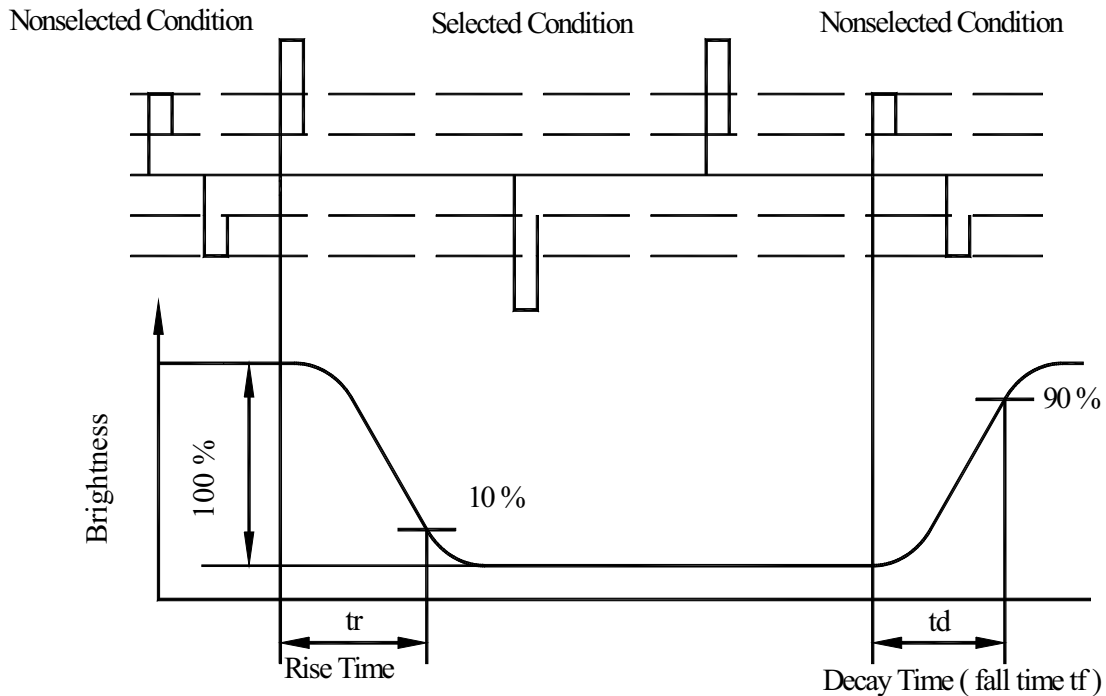

## 7. Interface Description

Pin No.	Symbol	Level	Description
1	V <sub>SS</sub>	0V	Ground
2	V <sub>DD</sub>	5.0V	Power supply for Logic
3	V <sub>O</sub>	(Variable)	Driving voltage for LCD
4	A0	H/L	RD=L WR=H ,A0=L :Data Read AO=H :Status read RD=H WR=L ,A0=L :Data Write AO=H :Command write
5	$\overline{\text{WR}}$	H/L	8080 family: Write signal, 6800 family: R/W signal
6	$\overline{\text{RD}}$	H/L	8080 family: Read signal, 6800 family: Enable clock
7~14	DB0~DB7	H/L	Data bus line
15	$\overline{\text{CS}}$	H/L	Chip select ,Active L
16	$\overline{\text{RES}}$	H/L	Controller reset signal, Active L
17	V <sub>cc</sub>		Negative Voltage Output
18	SEL		8088 or 6800 interface selection 1:68 0: 80
19	FG		Frame Ground
20	WAIT		Check Busy



# 8. Contour Drawing & Block diagram

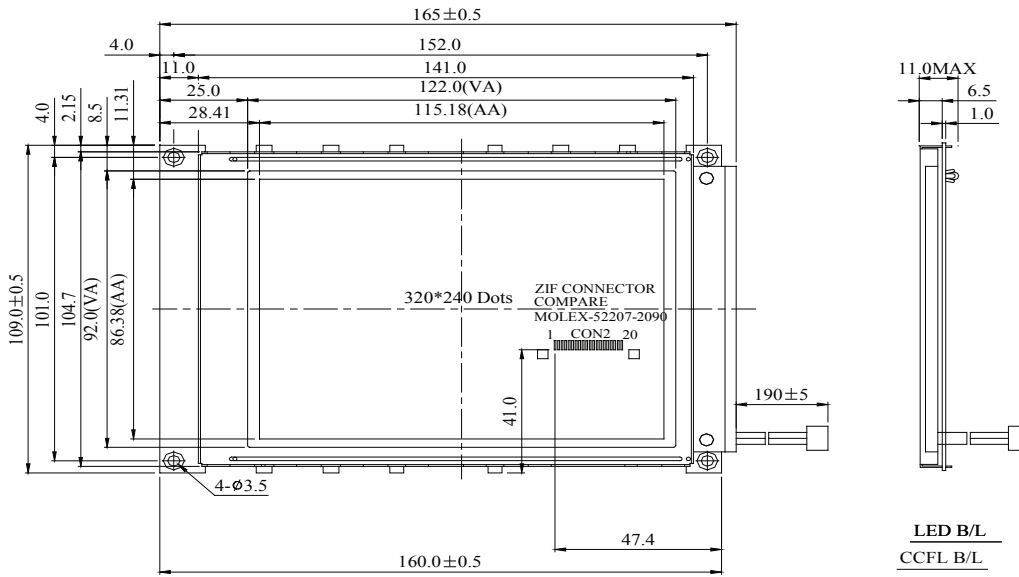

PIN NO.	SYMBOL
1	Vss
2	Vdd
3	Vo
4	A0
5	WR
6	RD
7	DB0
8	DB1
9	DB2
10	DB3
11	DB4
12	DB5
13	DB6
14	DB7
15	CS
16	RES
17	Vee
18	SEL1
19	FGND
20	NC

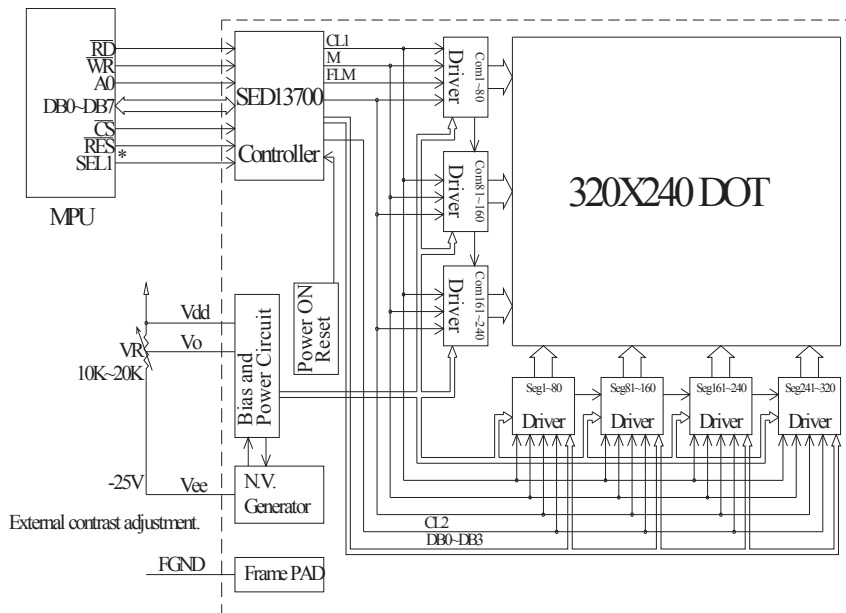
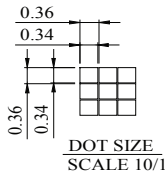

LEDB/L drive directly from AK.

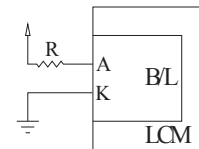

\*:6800 family or 8080family interface selectable.

## 9. Timing Characteristics

For relative timing diagram please see the spec of S1D13700.

### 9.1 Differences Between SED1335 and S1D13700

- 1 . S1D13700 almost can replace SED1335 , and it can drive 240\*160 dots in 16 gray level, or 320\*240 dots in 4 gray level.
- 2 . There are 2 Main differences and being described as below:
  - (1) . The Check Busy method of SED1335 is reading the D6 of **STATUS resister**.

Please

### 14. STATUS FLAG

The SED1335 series has a single bit status flag.

D6: X line standby

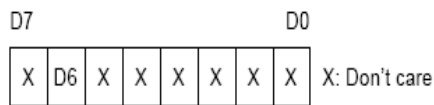

The D6 status flag is HIGH for the TC/R-C/R cycles at the end of each line where the SED1335 series is not reading the display memory. The microprocessor may use this period to update display memory without affecting the display, however it is recommended that the display be turned off when refreshing the whole display.

Figure 53. Status flag

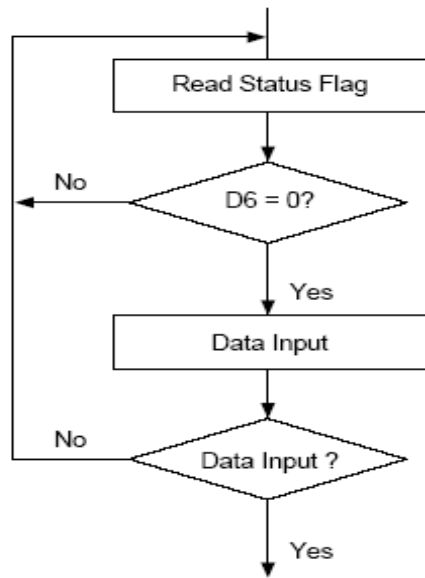
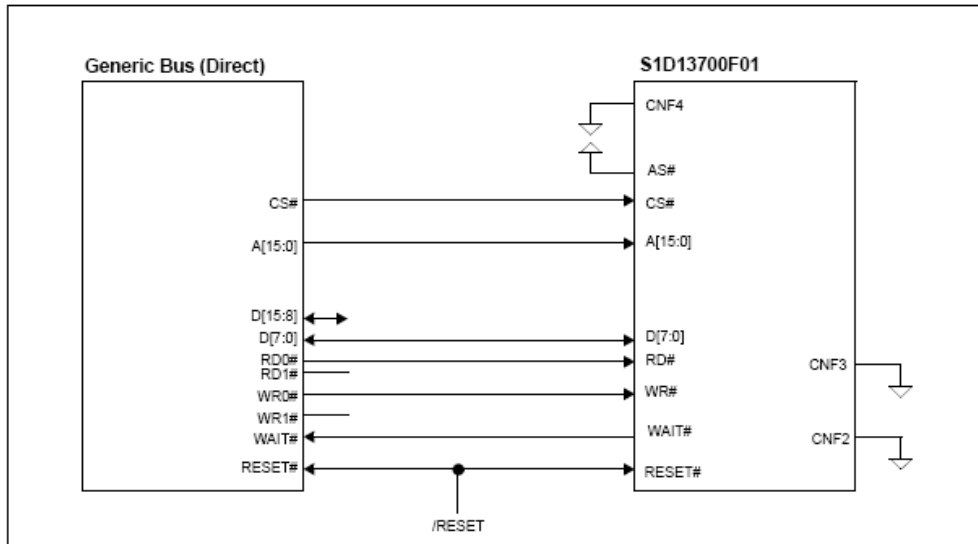

Figure 55. Flowchart for busy flag checking

The Check Busy method of S1D13700 is checking the “WAIT” pin directly. .



(2) Owing to S1D13700 having 32K\*8 SRAM inside, so It doesn't need to set the bit "M1" in "SYSTEM SET". For S1D13700, we doesn't set M1 (bit1) , the setting for SED 1335 is shown as below:

#### 8.2.1.1. C

This control byte performs the following:

1. Resets the internal timing generator
2. Disables the display
3. Cancels sleep mode

Parameters following P1 are not needed if only canceling sleep mode.

#### 8.2.1.2. M0

Selects the internal or external character generator ROM. The internal character generator ROM contains 160, 5 × 7 pixel characters, as shown in figure 70. These characters are fixed at fabrication by the metallization mask. The external character generator ROM, on the other hand, can contain up to 256 user-defined characters.

M0 = 0: Internal CG ROM  
M0 = 1: External CG ROM

Note that if the CG ROM address space overlaps the display memory address space, that portion of the display memory cannot be written to.

#### 8.2.1.3. M1

Selects the memory configuration for user-definable characters. The CG RAM codes select one of the 64 codes shown in figure 46.

M1 = 0: No D6 correction.

The CG RAM1 and CG RAM2 address spaces are not contiguous, the CG RAM1 address space is treated as character generator RAM, and the CG RAM2 address space is treated as character generator ROM.

M1 = 1: D6 correction.

The CG RAM1 and CG RAM2 address spaces are contiguous and are both treated as character generator RAM

The setting of S1D13700 will show as follow:

bit 1	Reserved The default value for this bit is 0.
bit 0	Character Generator Select (M0) This bit determines whether characters are generated by the internal character generator ROM (CGROM) or character generator RAM (CGRAM). The CGROM contains 160, 5x7 pixel characters which are fixed at fabrication. The CGRAM can contain up to 256 user-defined characters which are mapped at the CG Start Address (REG[1Ah] - REG[19h]). However, when the CGROM is used, the CGRAM can only contain up to 64, 8x8 pixel characters. When this bit = 0, the internal CGROM is selected. When this bit = 1, the internal CGRAM is selected.

#### Note

If the CGRAM is used (includes CGRAM1 and CGRAM2), only 1 bpp is supported.

# 10.RELIABILITY

## Content of Reliability Test (wide temperature, -20°C~70°C)

Environmental Test			
Test Item	Content of Test	Test Condition	Note
High Temperature storage	Endurance test applying the high storage temperature for a long time.	80°C 200hrs	2
Low Temperature storage	Endurance test applying the high storage temperature for a long time.	-30°C 200hrs	1,2
High Temperature Operation	Endurance test applying the electric stress (Voltage & Current) and the thermal stress to the element for a long time.	70°C 200hrs	—
Low Temperature Operation	Endurance test applying the electric stress under low temperature for a long time.	-20°C 200hrs	1
High Temperature/ Humidity Operation	The module should be allowed to stand at 60°C,90%RH max For 96hrs under no-load condition excluding the polarizer, Then taking it out and drying it at normal temperature.	60°C,90%RH 96hrs	1,2
Thermal shock resistance	The sample should be allowed stand the following 10 cycles of operation <div style="text-align: center;"> <p style="text-align: center;">-20°C    25°C    70°C</p> <p style="text-align: center;">30min    5min    30min</p> <p style="text-align: center;">1 cycle</p> </div>	-20°C/70°C 10 cycles	—
Vibration test	Endurance test applying the vibration during transportation and using.	Total fixed amplitude : 15mm Vibration Frequency : 10~55Hz One cycle 60 seconds to 3 directions of X,Y,Z for Each 15 minutes	3
Static electricity test	Endurance test applying the electric stress to the terminal.	VS=800V,RS=1.5kΩ CS=100pF 1 time	—

**Note1: No dew condensation to be observed.**

**Note2: The function test shall be conducted after 4 hours storage at the normal Temperature and humidity after remove from the test chamber.**

**Note3: Vibration test will be conducted to the product itself without putting it in a container.**

## 11. Backlight Information

### CCFL backlight Specification

(AT=25°C)

Item	Symbol	Specification			Unit	Condition
		Min	Typ	Max		
Luminance Frequency	FL	40	50	60	KHZ	—
Tube current	I <sub>L</sub>	3.5	5.0	6.5	mArms	—
Output Open Voltage	V <sub>Open</sub>	1100	—	—	Vrms	No load voltage
Tube Voltage	V <sub>LoadS</sub>	—	335	—	Vrms	—
Brightness	B	2500	—	—	Cd/m <sup>2</sup>	I <sub>FL</sub> =5.0mArms
Brightness Uniformity	Bu	75%	—	—	%	I <sub>FL</sub> =5.0mArms
Life time	—	<b>50,000</b>	—	—	hrs	

CCFL Connector: XHP-3 (JST)

# 12. Inspection specification

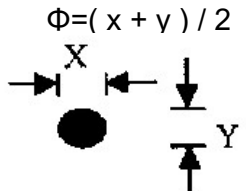
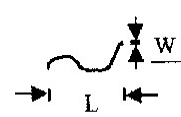
NO	Item	Criterion	AQL													
01	Electrical Testing	1.1 Missing vertical, horizontal segment, segment contrast defect. 1.2 Missing character, dot or icon. 1.3 Display malfunction. 1.4 No function or no display. 1.5 Current consumption exceeds product specifications. 1.6 LCD viewing angle defect. 1.7 Mixed product types. 1.8 Contrast defect.	0.65													
02	Black or white spots on LCD (display only)	2.1 White and black spots on display $\leq 0.25\text{mm}$ , no more than three white or black spots present. 2.2 Densely spaced: No more than two spots or lines within 3mm	2.5													
03	LCD black spots, white spots, contamination (non-display)	3.1 Round type : As following drawing  <table border="1" data-bbox="860 766 1315 1144"> <thead> <tr> <th>SIZE</th> <th>Acceptable Q TY</th> </tr> </thead> <tbody> <tr> <td><math>\Phi \leq 0.10</math></td> <td>Accept no dense</td> </tr> <tr> <td><math>0.10 &lt; \Phi \leq 0.20</math></td> <td>2</td> </tr> <tr> <td><math>0.20 &lt; \Phi \leq 0.25</math></td> <td>1</td> </tr> <tr> <td><math>0.25 &lt; \Phi</math></td> <td>0</td> </tr> </tbody> </table>	SIZE	Acceptable Q TY	$\Phi \leq 0.10$	Accept no dense	$0.10 < \Phi \leq 0.20$	2	$0.20 < \Phi \leq 0.25$	1	$0.25 < \Phi$	0	2.5			
		SIZE	Acceptable Q TY													
$\Phi \leq 0.10$	Accept no dense															
$0.10 < \Phi \leq 0.20$	2															
$0.20 < \Phi \leq 0.25$	1															
$0.25 < \Phi$	0															
3.2 Line type : (As following drawing)  <table border="1" data-bbox="706 1176 1315 1438"> <thead> <tr> <th>Length</th> <th>Width</th> <th>Acceptable Q TY</th> </tr> </thead> <tbody> <tr> <td>---</td> <td><math>W \leq 0.02</math></td> <td>Accept no dense</td> </tr> <tr> <td><math>L \leq 3.0</math></td> <td><math>0.02 &lt; W \leq 0.03</math></td> <td rowspan="2">2</td> </tr> <tr> <td><math>L \leq 2.5</math></td> <td><math>0.03 &lt; W \leq 0.05</math></td> </tr> <tr> <td>---</td> <td><math>0.05 &lt; W</math></td> <td>As round type</td> </tr> </tbody> </table>	Length	Width	Acceptable Q TY	---	$W \leq 0.02$	Accept no dense	$L \leq 3.0$	$0.02 < W \leq 0.03$	2	$L \leq 2.5$	$0.03 < W \leq 0.05$	---	$0.05 < W$	As round type	2.5	
Length	Width	Acceptable Q TY														
---	$W \leq 0.02$	Accept no dense														
$L \leq 3.0$	$0.02 < W \leq 0.03$	2														
$L \leq 2.5$	$0.03 < W \leq 0.05$															
---	$0.05 < W$	As round type														
04	Polarizer bubbles	If bubbles are visible, judge using black spot specifications, not easy to find, must check in specify direction.	<table border="1" data-bbox="828 1470 1315 1774"> <thead> <tr> <th>Size <math>\Phi</math></th> <th>Acceptable Q TY</th> </tr> </thead> <tbody> <tr> <td><math>\Phi \leq 0.20</math></td> <td>Accept no dense</td> </tr> <tr> <td><math>0.20 &lt; \Phi \leq 0.50</math></td> <td>3</td> </tr> <tr> <td><math>0.50 &lt; \Phi \leq 1.00</math></td> <td>2</td> </tr> <tr> <td><math>1.00 &lt; \Phi</math></td> <td>0</td> </tr> <tr> <td>Total Q TY</td> <td>3</td> </tr> </tbody> </table>	Size $\Phi$	Acceptable Q TY	$\Phi \leq 0.20$	Accept no dense	$0.20 < \Phi \leq 0.50$	3	$0.50 < \Phi \leq 1.00$	2	$1.00 < \Phi$	0	Total Q TY	3	2.5
Size $\Phi$	Acceptable Q TY															
$\Phi \leq 0.20$	Accept no dense															
$0.20 < \Phi \leq 0.50$	3															
$0.50 < \Phi \leq 1.00$	2															
$1.00 < \Phi$	0															
Total Q TY	3															

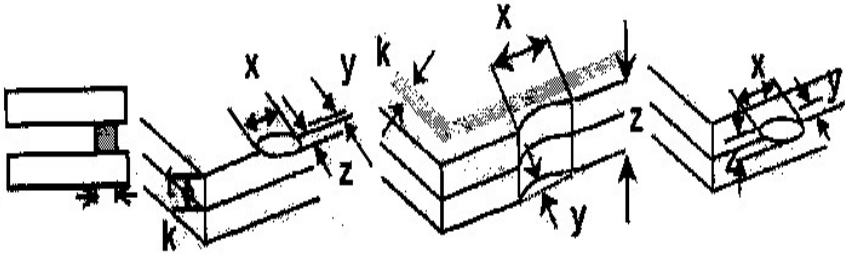
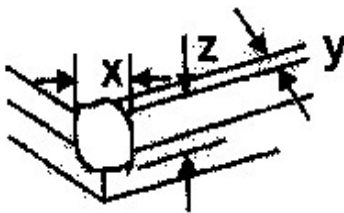
NO	Item	Criterion	AQL															
05	Scratches	Follow NO.3 LCD black spots, white spots, contamination																
06	Chipped glass	<p>Symbols Define:  x: Chip length      y: Chip width      z: Chip thickness  k: Seal width      t: Glass thickness      a: LCD side length  L: Electrode pad length:</p> <p>6.1 General glass chip :  6.1.1 Chip on panel surface and crack between panels:</p>  <table border="1" data-bbox="459 1050 1307 1291"> <thead> <tr> <th>z: Chip thickness</th> <th>y: Chip width</th> <th>x: Chip length</th> </tr> </thead> <tbody> <tr> <td><math>z \leq 1/2t</math></td> <td>Not over viewing area</td> <td><math>x \leq 1/8a</math></td> </tr> <tr> <td><math>1/2t &lt; z \leq 2t</math></td> <td>Not exceed 1/3k</td> <td><math>x \leq 1/8a</math></td> </tr> </tbody> </table> <p>⊙If there are 2 or more chips, x is total length of each chip.</p> <p>6.1.2 Corner crack:</p>  <table border="1" data-bbox="459 1743 1307 1858"> <thead> <tr> <th>z: Chip thickness</th> <th>y: Chip width</th> <th>x: Chip length</th> </tr> </thead> <tbody> <tr> <td><math>z \leq 1/2t</math></td> <td>Not over viewing</td> <td><math>x \leq 1/8a</math></td> </tr> </tbody> </table>	z: Chip thickness	y: Chip width	x: Chip length	$z \leq 1/2t$	Not over viewing area	$x \leq 1/8a$	$1/2t < z \leq 2t$	Not exceed 1/3k	$x \leq 1/8a$	z: Chip thickness	y: Chip width	x: Chip length	$z \leq 1/2t$	Not over viewing	$x \leq 1/8a$	2.5
z: Chip thickness	y: Chip width	x: Chip length																
$z \leq 1/2t$	Not over viewing area	$x \leq 1/8a$																
$1/2t < z \leq 2t$	Not exceed 1/3k	$x \leq 1/8a$																
z: Chip thickness	y: Chip width	x: Chip length																
$z \leq 1/2t$	Not over viewing	$x \leq 1/8a$																

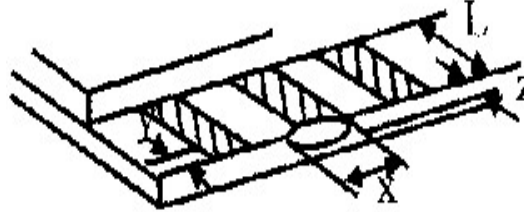
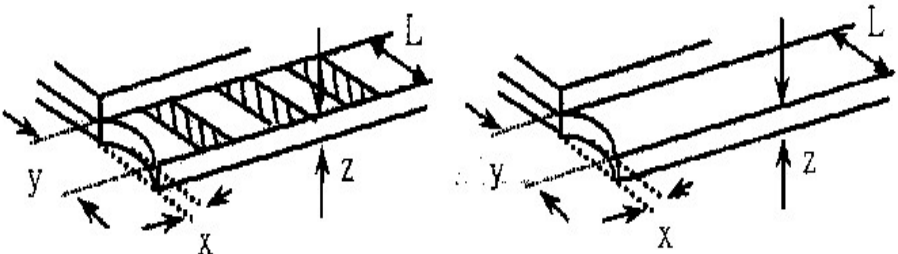
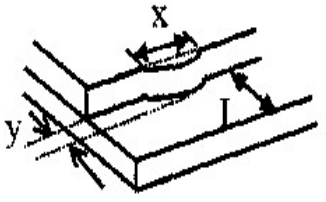

			area		
		$1/2t < z \leq 2t$	Not exceed $1/3k$	$x \leq 1/8a$	
<p>⊙If there are 2 or more chips, x is the total length of each chip.</p>					

NO	Item	Criterion	AQL																
06	Glass crack	<p>Symbols :</p> <p>x: Chip length      y: Chip width      z: Chip thickness  k: Seal width      t: Glass thickness      a: LCD side length  L: Electrode pad length</p> <p>6.2 Protrusion over terminal :</p> <p>6.2.1 Chip on electrode pad :</p>  <table border="1" data-bbox="381 598 1226 703"> <tr> <td>y: Chip width</td> <td>x: Chip length</td> <td>z: Chip thickness</td> </tr> <tr> <td><math>y \leq 0.5\text{mm}</math></td> <td><math>x \leq 1/8a</math></td> <td><math>0 &lt; z \leq t</math></td> </tr> </table> <p>6.2.2 Non-conductive portion:</p>  <table border="1" data-bbox="446 1029 1226 1186"> <tr> <td>y: Chip width</td> <td>x: Chip length</td> <td>z: Chip thickness</td> </tr> <tr> <td><math>y \leq L</math></td> <td><math>x \leq 1/8a</math></td> <td><math>0 &lt; z \leq t</math></td> </tr> </table> <p>⊙If the chipped area touches the ITO terminal, over 2/3 of the ITO must remain and be inspected according to electrode terminal specifications.</p> <p>⊙If the product will be heat sealed by the customer, the alignment mark not be damaged.</p> <p>6.2.3 Substrate protuberance and internal crack.</p>  <table border="1" data-bbox="763 1512 1234 1627"> <tr> <td>y: width</td> <td>x: length</td> </tr> <tr> <td><math>y \leq 1/3L</math></td> <td><math>x \leq a</math></td> </tr> </table>	y: Chip width	x: Chip length	z: Chip thickness	$y \leq 0.5\text{mm}$	$x \leq 1/8a$	$0 < z \leq t$	y: Chip width	x: Chip length	z: Chip thickness	$y \leq L$	$x \leq 1/8a$	$0 < z \leq t$	y: width	x: length	$y \leq 1/3L$	$x \leq a$	2.5
y: Chip width	x: Chip length	z: Chip thickness																	
$y \leq 0.5\text{mm}$	$x \leq 1/8a$	$0 < z \leq t$																	
y: Chip width	x: Chip length	z: Chip thickness																	
$y \leq L$	$x \leq 1/8a$	$0 < z \leq t$																	
y: width	x: length																		
$y \leq 1/3L$	$x \leq a$																		

NO	Item	Criterion	AQL
----	------	-----------	-----

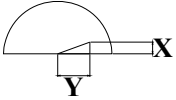
07	Cracked glass	The LCD with extensive crack is not acceptable.	2.5
08	Backlight elements	8.1 Illumination source flickers when lit. 8.2 Spots or scratched that appear when lit must be judged. Using LCD spot, lines and contamination standards. 8.3 Backlight doesn't light or color wrong.	0.65 2.5 0.65
09	Bezel	9.1 Bezel may not have rust, be deformed or have fingerprints, stains or other contamination. 9.2 Bezel must comply with job specifications.	2.5 0.65
10	PCB, COB	10.1 COB seal may not have pinholes larger than 0.2mm or contamination. 10.2 COB seal surface may not have pinholes through to the IC. 10.3 The height of the COB should not exceed the height indicated in the assembly diagram. 10.4 There may not be more than 2mm of sealant outside the seal area on the PCB. And there should be no more than three places. 10.5 No oxidation or contamination PCB terminals. 10.6 Parts on PCB must be the same as on the production characteristic chart. There should be no wrong parts, missing parts or excess parts. 10.7 The jumper on the PCB should conform to the product characteristic chart. 10.8 If solder gets on bezel tab pads, LED pad, zebra pad or screw hold pad, make sure it is smoothed down. 10.9 The Scraping testing standard for Copper Coating of PCB  $X * Y \leq 2mm^2$	2.5 2.5 0.65 2.5 2.5 0.65 2.5 2.5 2.5 2.5
11	Soldering	11.1 No un-melted solder paste may be present on the PCB. 11.2 No cold solder joints, missing solder connections, oxidation or icicle. 11.3 No residue or solder balls on PCB. 11.4 No short circuits in components on PCB.	2.5 2.5 2.5 0.65

NO	Item	Criterion	AQL
12	General appearance	12.1 No oxidation, contamination, curves or, bends on interface Pin (OLB) of TCP.	2.5
		12.2 No cracks on interface pin (OLB) of TCP.	0.65
		12.3 No contamination, solder residue or solder balls on product.	2.5
			2.5
		12.4 The IC on the TCP may not be damaged, circuits.	2.5
		12.5 The uppermost edge of the protective strip on the interface pin must be present or look as if it cause the interface pin to sever.	2.5
		12.6 The residual rosin or tin oil of soldering (component or chip component) is not burned into brown or black color.	2.5
			0.65
		12.7 Sealant on top of the ITO circuit has not hardened.	0.65
		12.8 Pin type must match type in specification sheet.	0.65
		12.9 LCD pin loose or missing pins.	
12.10 Product packaging must the same as specified on packaging specification sheet.	0.65		
12.11 Product dimension and structure must conform to product specification sheet.			