



Chipsmall Limited consists of a professional team with an average of over 10 year of expertise in the distribution of electronic components. Based in Hongkong, we have already established firm and mutual-benefit business relationships with customers from,Europe,America and south Asia,supplying obsolete and hard-to-find components to meet their specific needs.

With the principle of “Quality Parts,Customers Priority,Honest Operation,and Considerate Service”,our business mainly focus on the distribution of electronic components. Line cards we deal with include Microchip,ALPS,ROHM,Xilinx,Pulse,ON,Everlight and Freescale. Main products comprise IC,Modules,Potentiometer,IC Socket,Relay,Connector.Our parts cover such applications as commercial,industrial, and automotives areas.

We are looking forward to setting up business relationship with you and hope to provide you with the best service and solution. Let us make a better world for our industry!



Contact us

Tel: +86-755-8981 8866 Fax: +86-755-8427 6832

Email & Skype: info@chipsmall.com Web: www.chipsmall.com

Address: A1208, Overseas Decoration Building, #122 Zhenhua RD., Futian, Shenzhen, China



NHD-5.0-800480TF-ATXL#-T

TFT (Thin-Film-Transistor) Color Liquid Crystal Display Module

NHD-	Newhaven Display
5.0-	5.0" Diagonal
800480-	800xRGBx480 Pixels
TF-	Model
A-	Built-in Driver / No Controller
T-	White LED Backlight
X-	TFT
L-	MVA, Enhanced Optical Characteristics, Wide Temperature
#-	RoHS Compliant
T-	4-wire Resistive Touch Panel

Newhaven Display International, Inc.

2661 Galvin Court

Elgin IL, 60124

Ph: 847-844-8795

Fax: 847-844-8796

www.newhavendisplay.com

nhtech@newhavendisplay.com

nhsales@newhavendisplay.com

Document Revision History

Revision	Date	Description	Changed by
0	8/28/13	Initial Release	AK
1	9/16/14	Electrical Characteristics updated	ML
2	9/2/15	Driver, Electrical, Optical characteristics updated	AK
3	11/2/15	Backlight Lifetime Rating Added, Datasheet Reformat	SB
4	2/23/16	Corrected Notes on Drawing	SB
5	7/22/16	Updated Mechanical Drawing, Electrical Characteristics	TM
6	4/14/17	Supply Current Updated	SB

Functions and Features

- 800xRGBx480 resolution, up to 16.7M colors
- 18-LED backlight
- 24 bit RGB interface
- Enhanced Optical Characteristics
- 4-wire Resistive Touch Panel
- Wide Viewing Angles

Mechanical Drawing

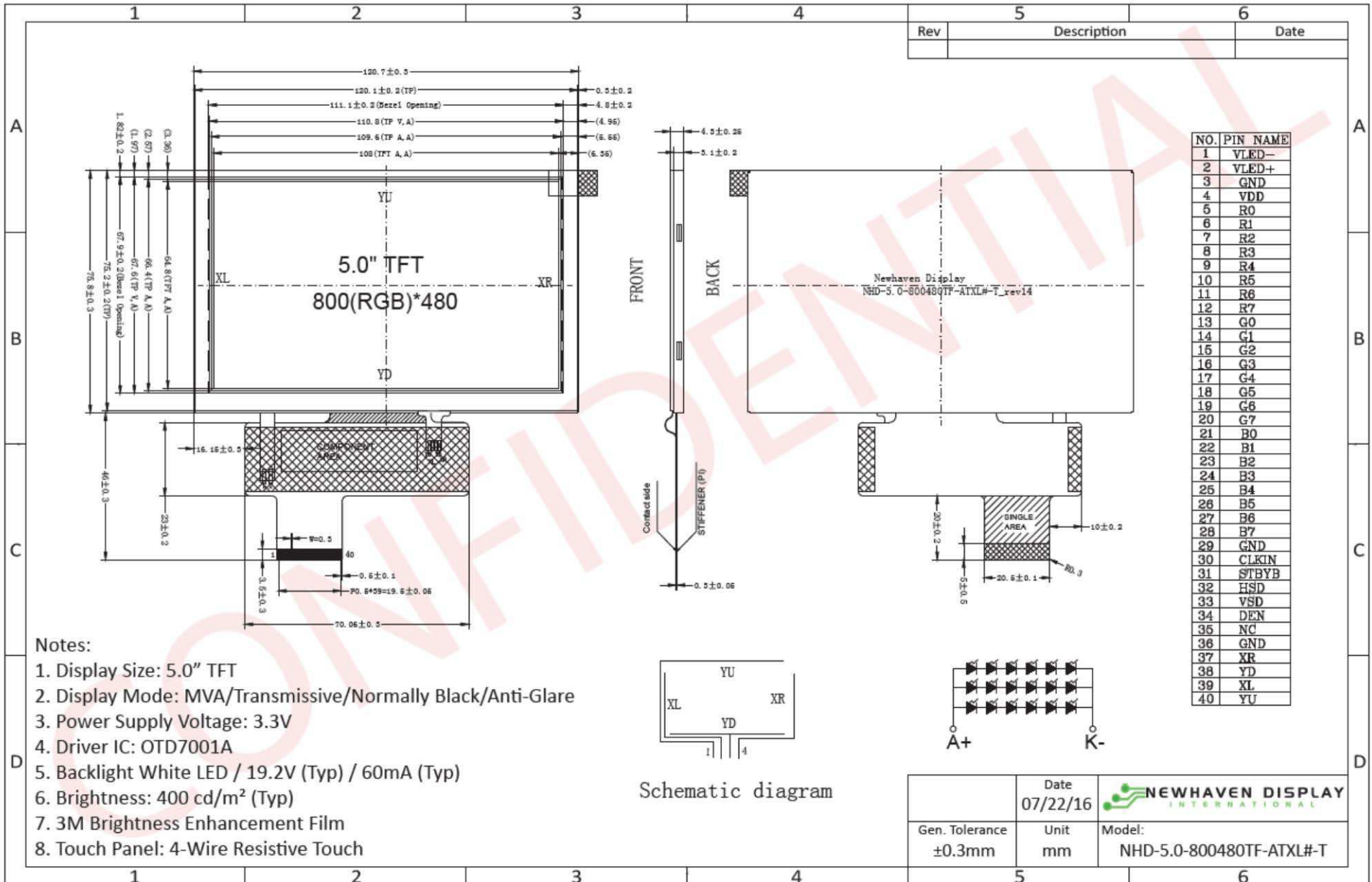

The drawing contained herein is the exclusive property of Newhaven Display International, Inc. and shall not be copied, reproduced, and/or disclosed in any format without permission.

Pin Description

Pin No.	Symbol	External Connection	Function Description
1	LED-	LED Power Supply	Ground for Backlight
2	LED+	LED Power Supply	Backlight Power Supply (60mA @ 19.2V)
3	GND	Power Supply	Ground
4	V _{DD}	Power Supply	Power supply for LCD and logic (3.3V)
5-12	[R0-R7]	MPU	Red Data Signals
13-20	[G0-G7]	MPU	Green Data Signals
21-28	[B0-B7]	MPU	Blue Data Signals
29	GND	Power Supply	Ground
30	CLKIN	MPU	Clock for input data (Rising Edge)
31	STBYB	MPU	1: Normal Operation; 0: Standby Mode
32	HSD	MPU	Line synchronization signal
33	VSD	MPU	Frame synchronization signal
34	DEN	MPU	Data Enable signal
35	NC	-	No Connect
36	GND	Power Supply	Ground
37	XR	Touch Controller	Touch Panel Right
38	YD	Touch Controller	Touch Panel Down
39	XL	Touch Controller	Touch Panel Left
40	YU	Touch Controller	Touch Panel Up

Recommended LCD connector: 0.5mm pitch 40-Conductor FFC. Molex p/n: 54104-4031 (top contact)

Backlight connector: on LCD connector

Mates with: ---

Electrical Characteristics

Item	Symbol	Condition	Min.	Typ.	Max.	Unit
Operating Temperature Range	T _{OP}	Absolute Max	-20	-	+70	°C
Storage Temperature Range	T _{ST}	Absolute Max	-30	-	+80	°C
Supply Voltage	V _{DD}	-	3.0	3.3	3.6	V
Supply Current	I _{DD}	V _{DD} = 3.3V	50	100	170	mA
"H" Level input	V _{IH}	-	0.7*VDD	-	VDD	V
"L" Level input	V _{IL}	-	0	-	0.3*VDD	V
"H" Level output	V _{OH}	-	VDD-0.4	-	-	V
"L" Level output	V _{OL}	-	-	-	VSS+0.4	V
Backlight Supply Current	I _{LED}	-	-	60	75	mA
Backlight Supply Voltage	V _{LED}	I _{LED} = 60mA	17.4	19.2	19.8	V
Backlight Lifetime*	-	I _{LED} = 60mA T _{OP} = 25°C	20,000	50,000	-	hrs

*Backlight lifetime is rated as Hours until **half-brightness**, under normal operating conditions. The LED of the backlight is driven by current drain; drive voltage is for reference only. Drive voltage must be selected to ensure backlight current drain is below MAX level stated.

Optical Characteristics

Item	Symbol	Condition	Min.	Typ.	Max.	Unit
Optimal Viewing Angles	Top	CR ≥ 10	60	75	-	°
	Bottom		60	75	-	°
	Left		60	75	-	°
	Right		60	75	-	°
Contrast Ratio	CR	-	-	350	-	-
Luminance	L _V	I _{LED} = 60 mA	320	400	-	cd/m ²
Response Time	T _R + T _F	T _{OP} = 25°C	-	20	30	ms

Touch Panel Characteristics

Item	Min.	Typ.	Max.	Unit
Linearity	-1.5	-	1.5	%
Circuit Resistance – X-Axis	350	-	1000	Ω
Circuit Resistance – Y-Axis	100	-	450	Ω
Insulation Resistance	20	-	-	MΩ
Operating Voltage	-	-	10	V
Chattering	-	-	10	ms
Transmittance	80	-	-	%
Activation Force	20	-	100	g
Pen Writing Durability	100,000	-	-	Characters
Pitting Durability	1,000,000	-	-	Touches
Surface Hardness	3	-	-	H
Haze	4	7	10	%

Driver Information

Built-in OTA7001A Source Driver: http://www.newhavendisplay.com/app_notes/OTA7001A_V04.pdf

Built in OTD9960A Gate Driver: http://www.newhavendisplay.com/app_notes/OTD9960A_V03.pdf

Timing Characteristics

Horizontal input timing

Parameter	Symbol	Value			Unit
		Min.	Typ.	Max.	
Horizontal display area	thd	800			DCLK
DCLK frequency	fclk	-	30	50	MHz
1 Horizontal Line	th	928			DCLK
HSD pulse width	thpw	Min.	1		
		Typ.	48		
		Max.	-		
HSD Back Porch (Blanking)	thb	-	88	-	
HSD Front Porch	thfp	-	40	-	

Vertical input timing

Parameter	Symbol	Value			Unit
		Min.	Typ.	Max.	
Vertical display area	tvd	480			H
VSD period time	tv	-	525	-	H
VSD pulse width	tvpw	-	3	-	H
VSD Back Porch (Blanking)	tvb	-	32	-	H
VSD Front Porch	tvfp	-	13	-	H

Parameter	Symbol	MIN.	Typ.	MAX.	UNIT	Conditions
VDD Power On Slew rate	T	-	-	20	ms	From 0V to 90% VDD
RSTB pulse width	T	10	-	-	us	CLKIN = 45MHz
CLKIN cycle time	Tcph	20	-	-	ns	
CLKIN pulse duty	Tcwh	40	50	60	%	
VSD setup time	Tvst	8	-	-	ns	
VSD hold time	Tvhd	8	-	-	ns	
HSD setup time	Thst	8	-	-	ns	
HSD hold time	Thhd	8	-	-	ns	
Data set-up time	Tdsu	8	-	-	ns	D0[7:0], D1[7:0], D2[7:0] to CLKIN
Data hold time	Tdhd	8	-	-	ns	D0[7:0], D1[7:0], D2[7:0] to CLKIN
DE set-up time	Tesu	8	-	-	ns	
DE hold time	Tehd	8	-	-	ns	
Output stable time	Tsst	-	-	6	us	10% to 90% target voltage. CL=120pF, R=10K ohm

Parameter	Symbol	MIN.	Typ.	MAX.	UNIT	Conditions
CLKIN Frequency	Fclk	-	33	50	MHz	VDDD = 2.3V ~ 3.6V
CLKIN Cycle Time	Tclk	20	30	-	ns	
CLKIN Pulse Duty	Tcwh	40	50	60	%	Tclk
Time from HSD to Source Output	Thso	-	Tld		CLKIN	
Time from HSD to LD	Thld	-	Tld		CLKIN	
Time from HSD to STV	Thstv	-	2		CLKIN	
Time from HSD to CKV	Thckv	-	20		CLKIN	
Time from HSD to OEV	Thoev	-	4		CLKIN	
LD Pulse	Twd	-	10		CLKIN	
CKV Pulse Width	Twckv	-	66		CLKIN	
OEV Pulse Width	Twoev	-	Tld+10		CLKIN	

Vertical Input Timing

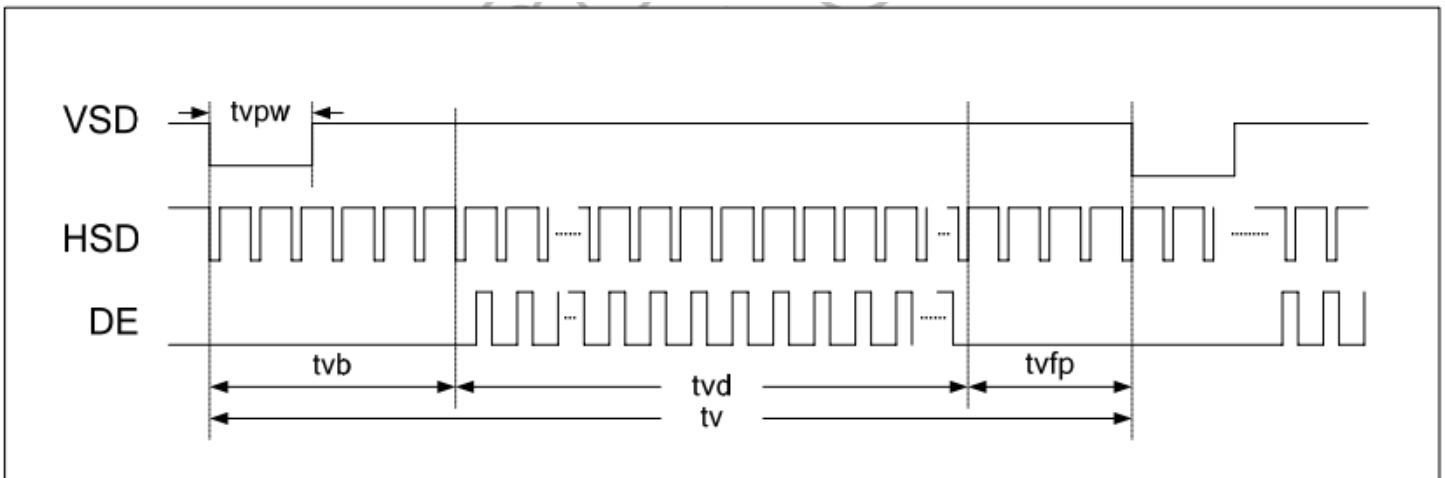

Horizontal Input Timing

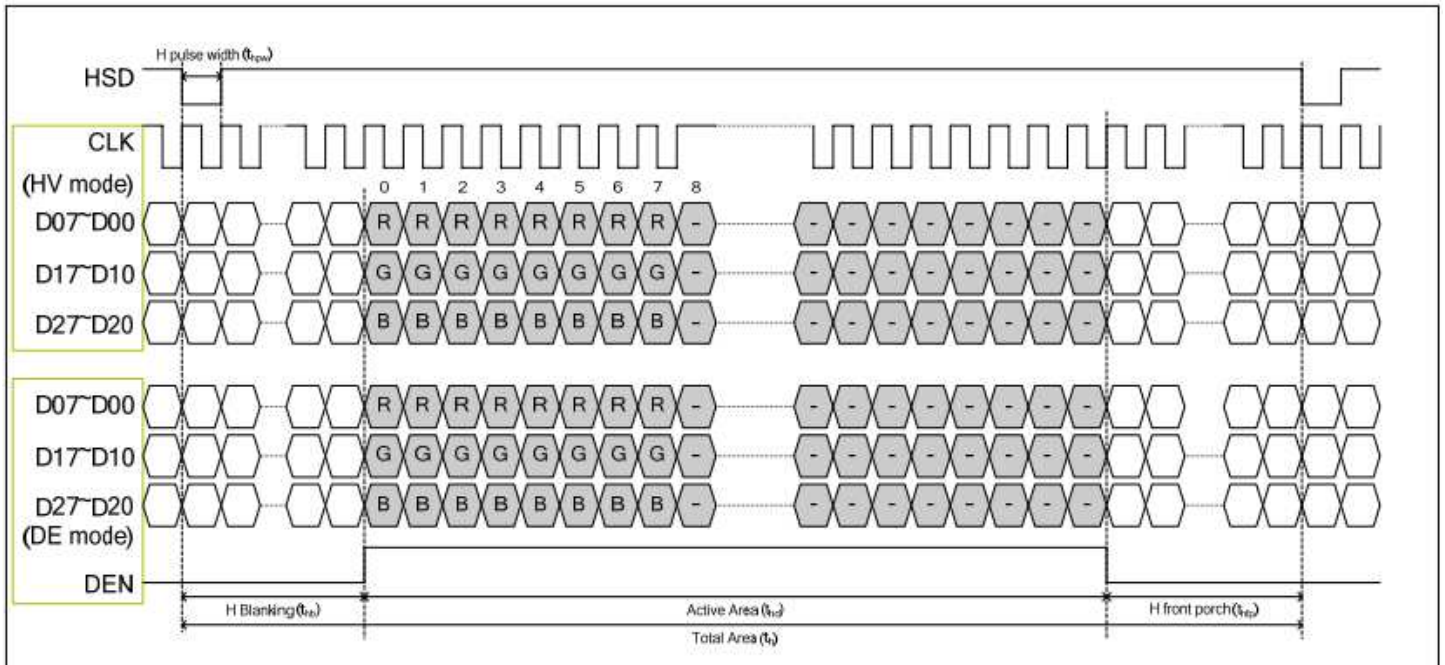

Input Clock and Data Timing

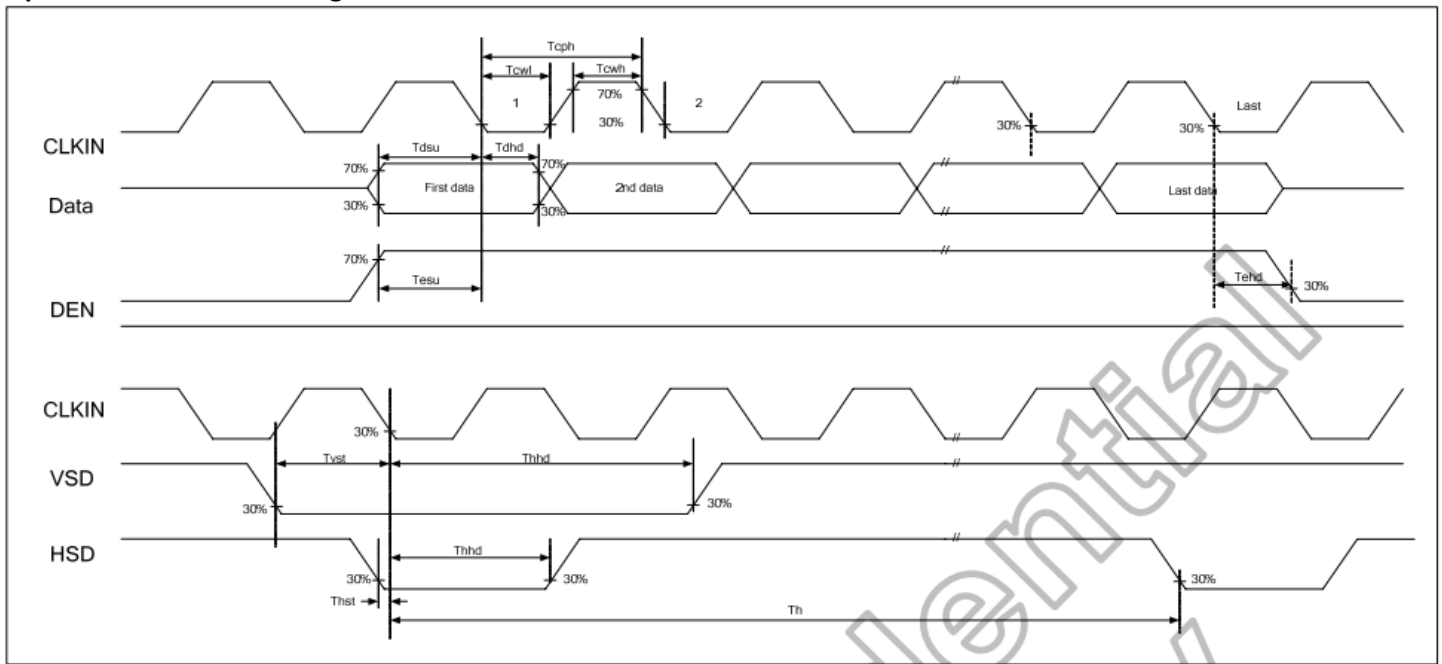

Source Output Timing

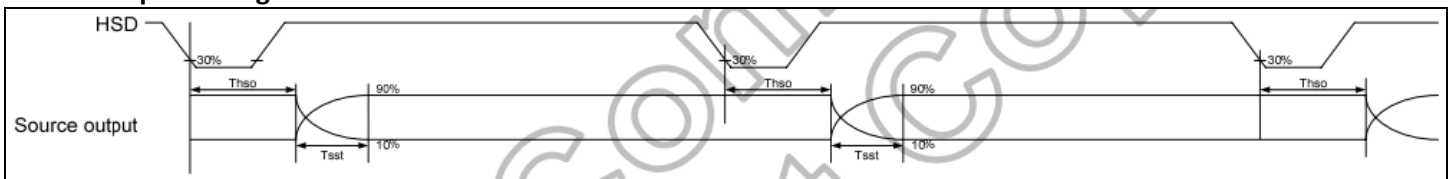

Power ON/OFF Sequence

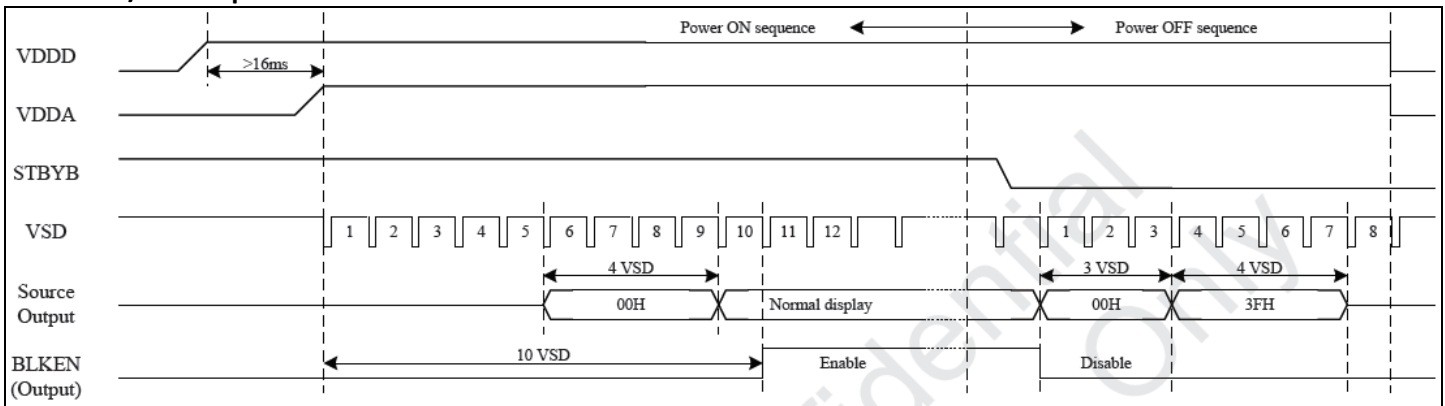

Enter/Exit Standby Mode Sequence

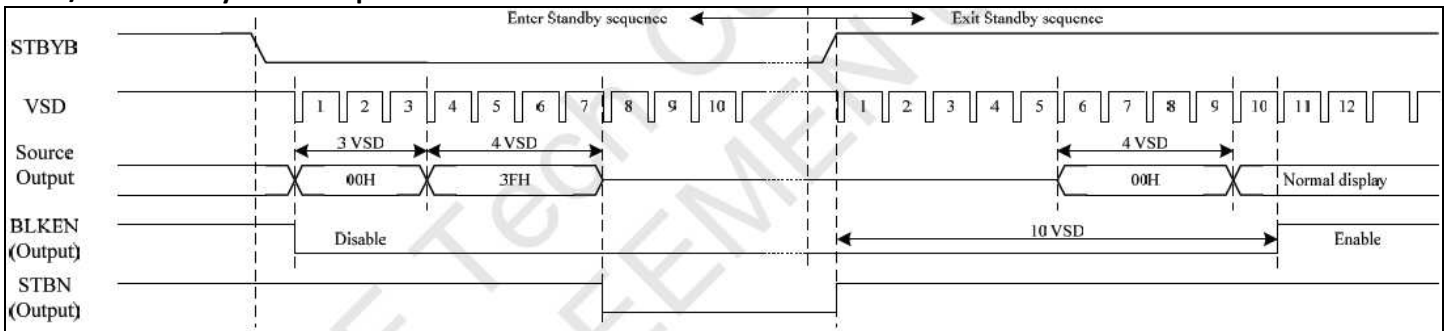

Quality Information

Test Item	Content of Test	Test Condition	Note
High Temperature storage	Endurance test applying the high storage temperature for a long time.	+80°C , 96hrs	2
Low Temperature storage	Endurance test applying the low storage temperature for a long time.	-30°C , 96hrs	1,2
High Temperature Operation	Endurance test applying the electric stress (voltage & current) and the high thermal stress for a long time.	+70°C 96hrs	2
Low Temperature Operation	Endurance test applying the electric stress (voltage & current) and the low thermal stress for a long time.	-20°C , 96hrs	1,2
High Temperature / Humidity Operation	Endurance test applying the electric stress (voltage & current) and the high thermal with high humidity stress for a long time.	+50°C , 90% RH , 96hrs	1,2
Thermal Shock resistance	Endurance test applying the electric stress (voltage & current) during a cycle of low and high thermal stress.	-20°C,60min -> 70°C,60min = 1 cycle For 20 cycles	
Vibration test	Endurance test applying vibration to simulate transportation and use.	10-50Hz, 5G in each of 3 directions X,Y,Z For 30 minutes each direction	3
Static electricity test	Endurance test applying electric static discharge.	Air: 8kV, 150pF, 330Ω, 5 times Contact: 4kV, 150pF, 330Ω, 5 times	

Note 1: No condensation to be observed.

Note 2: Conducted after 4 hours of storage at 25°C, 0%RH.

Note 3: Test performed on product itself, not inside a container.

Precautions for using LCDs/LCMs

See Precautions at www.newhavendisplay.com/specs/precautions.pdf

Warranty Information and Terms & Conditions

http://www.newhavendisplay.com/index.php?main_page=terms