



Chipsmall Limited consists of a professional team with an average of over 10 year of expertise in the distribution of electronic components. Based in Hongkong, we have already established firm and mutual-benefit business relationships with customers from,Europe,America and south Asia,supplying obsolete and hard-to-find components to meet their specific needs.

With the principle of “Quality Parts,Customers Priority,Honest Operation,and Considerate Service”,our business mainly focus on the distribution of electronic components. Line cards we deal with include Microchip,ALPS,ROHM,Xilinx,Pulse,ON,Everlight and Freescale. Main products comprise IC,Modules,Potentiometer,IC Socket,Relay,Connector.Our parts cover such applications as commercial,industrial, and automotives areas.

We are looking forward to setting up business relationship with you and hope to provide you with the best service and solution. Let us make a better world for our industry!



Contact us

Tel: +86-755-8981 8866 Fax: +86-755-8427 6832

Email & Skype: info@chipsmall.com Web: www.chipsmall.com

Address: A1208, Overseas Decoration Building, #122 Zhenhua RD., Futian, Shenzhen, China



NHD-7.0-800480EF-ATXL#-CTP

TFT (Thin-Film-Transistor) Color Liquid Crystal Display Module

NHD-	Newhaven Display
7.0-	7.0" Diagonal
800480-	800xRGBx480 pixels
EF-	Model
A-	Built-in driver / No Controller
T-	White LED backlight
X-	TFT
L-	12:00 Optimal View, Wide Temperature
#-	RoHS Compliant
CTP-	Capacitive Touch Panel with Controller

Newhaven Display International, Inc.

2661 Galvin Ct.

Elgin IL, 60124

Ph: 847-844-8795

Fax: 847-844-8796

www.newhavendisplay.com

nhtech@newhavendisplay.com

nhsales@newhavendisplay.com

Document Revision History

Revision	Date	Description	Changed by
0	8/30/2013	Initial Release	ML
1	4/1/2015	CTP mechanical dimensions updated	AK
2	3/15/16	Brightness Rating Updated, Backlight Lifetime Rating Added, Datasheet Reformat, CTP Voltage Updated	SB
3	7/5/16	Chromaticity Added	SB

Functions and Features

- 800xRGBx480 resolution
- LED backlight
- 24-bit digital RGB interface
- 16.7M colors
- Capacitive touch panel with controller
 - 5 point multi-touch input
 - Gesture input
 - Zoom In/Out
 - Swipe Up/Down/Left/Right

Mechanical Drawing

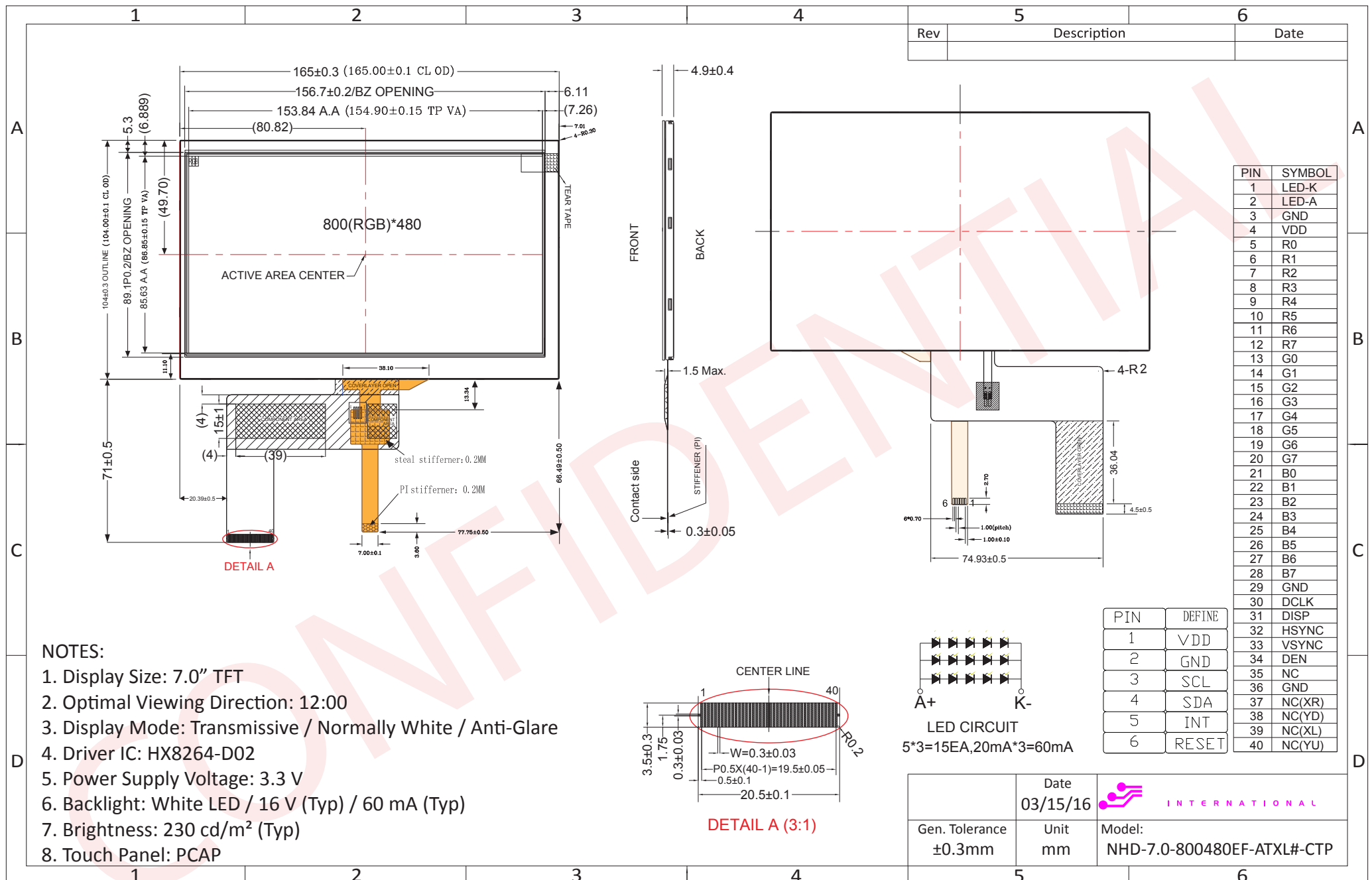

The drawing contained herein is the exclusive property of Newhaven Display International, Inc. and shall not be copied, reproduced, and/or disclosed in any format without permission.

Pin Description

TFT:

Pin No.	Symbol	Connection	Function Description
1	LED-K	Power Supply	Ground for Backlight
2	LED-A	Power Supply	Backlight Power Supply (60mA @ 16V)
3	GND	Power Supply	Ground
4	VDD	Power Supply	Power Supply (+3.3V)
5-12	[R0-R7]	MPU	Red Data Signals
13-20	[G0-G7]	MPU	Green Data Signals
21-28	[B0-B7]	MPU	Blue Data Signals
29	GND	Power Supply	Ground
30	CLKIN	MPU	Clock for input data
31	DISP	MPU	Display on/off DISP=1:Display on
32	HSD	MPU	Line synchronization signal
33	VSD	MPU	Frame synchronization signal
34	DEN	MPU	Data Enable signal
35	NC	-	No Connect
36	GND	Power Supply	Ground
37	NC(XR)	-	No Connect
38	NC(YD)	-	No Connect
39	NC(XL)	-	No Connect
40	NC(YU)	-	No Connect

LCD connector: 0.5mm pitch 40-Conductor FFC. Molex p/n: 54104-4031 (top contact)

Backlight connector: on LCD connector **Mates with:** ---

Capacitive Touch Panel:

Pin No.	Symbol	External Connection	Function Description
1	VDD	Power Supply	Power Supply (3.3V)
2	GND	Power Supply	Ground
3	SCL	MPU	Serial I2C Clock (Requires pull-up resistor)
4	SDA	MPU	Serial I2C Data (Requires pull-up resistor)
5	/INT	MPU	Interrupt signal from touch panel module to host
6	/RESET	MPU	Active LOW Reset signal.

Recommended connector: 1.0mm pitch 6-Conductor FFC. Molex p/n: 52271-0679

Driver/Controller Information

TFT:

Built-in HX8264-D02 Source Driver: http://www.newhavendisplay.com/app_notes/HX8264-D02.pdf

Built-in HX8664-B Gate Driver: http://www.newhavendisplay.com/app_notes/HX8664-B.pdf

Capacitive Touch Panel:

Built-in FocalTech FT5406 controller.

Please download specification at http://www.newhavendisplay.com/app_notes/FT5x06.pdf

Electrical Characteristics

TFT:

Item	Symbol	Condition	Min.	Typ.	Max.	Unit
Operating Temperature Range	T _{OP}	Absolute Max	-20	-	+70	°C
Storage Temperature Range	T _{ST}	Absolute Max	-30	-	+80	°C
Supply Voltage	V _{DD}	-	3.0	3.3	3.6	V
Supply Current	I _{DD}	V _{DD} =3.3V, 25°C	60	85	120	mA
"H" Level Input	V _{IH}	-	0.7*V _{DD}	-	V _{DD}	V
"L" Level Input	V _{IL}	-	V _{SS}	-	0.3*V _{DD}	V
"H" Level Output	V _{OH}	-	V _{DD} -0.4	-	-	V
"L" Level Output	V _{OL}	-	V _{SS}	-	V _{SS} +0.4	V
Backlight Supply Voltage	V _{LED}	-	14.5	16	16.5	V
Backlight Supply Current	I _{LED}	V _{LED} =16V	45	60	75	mA
Backlight Lifetime*	-	I _{LED} = 60 mA T _{OP} = 25° C	20,000	50,000	-	hrs.

*Backlight lifetime is rated as Hours until **half-brightness**, under normal operating conditions.

Capacitive Touch Panel:

Item	Symbol	Condition	Min.	Typ.	Max.	Unit
Operating Temperature Range	T _{OP}	Absolute Max	-20	-	+70	°C
Storage Temperature Range	T _{ST}	Absolute Max	-30	-	+80	°C
Supply Voltage	V _{DD}	-	2.8	3.3	3.6	V
Supply Current – Operating	I _{DD}	V _{DD} = 3.3V T _{OP} = 25°C	-	6.0	-	mA
Supply Current – Hibernate	I _{DD}		-	1.0	-	µA
"H" Level Input	V _{IH}	-	0.7*V _{DD}	-	V _{DD}	V
"L" Level Input	V _{IL}	-	V _{SS}	-	0.3*V _{DD}	V
"H" Level Output	V _{OH}	-	0.7*V _{DD}	-	V _{DD}	V
"L" Level Output	V _{OL}	-	V _{SS}	-	0.3*V _{DD}	V

Optical Characteristics

Item	Symbol	Condition	Min.	Typ.	Max.	Unit	
Optimal Viewing Angles	Top	CR ≥10	-	65	-	°	
	Bottom		-	55	-	°	
	Left		-	70	-	°	
	Right		-	70	-	°	
Contrast Ratio	CR	-	-	400	-	-	
Luminance	L _V	-	180	230	-	cd/m ²	
Response Time	T _R + T _F	-	-	25	35	ms	
Chromaticity	Red	X _R	-	0.540	0.590	0.640	-
		Y _R	-	0.307	0.357	0.407	-
	Green	X _G	-	0.287	0.337	0.387	-
		Y _G	-	0.551	0.601	0.651	-
	Blue	X _B	-	0.102	0.152	0.202	-
		Y _B	-	0.079	0.129	0.179	-
	White	X _W	-	0.260	0.310	0.360	-
		Y _W	-	0.280	0.330	0.380	-

Capacitive Touch Panel Material Characteristics:

Property	Requirement	Unit
IC	FT5406EE8	-
ITO Glass thickness	0.55	mm
Surface Hardness	≥6	H
Light transmission	83% ± 5%	-
Operating Humidity	20~90	RH
Storage Humidity	20~90	RH

Capacitive Touch Panel Registers

Address	Name	B7	B6	B5	B4	B3	B2	B1	B0	Access	
00h	DEVICE_MODE	Device Mode [2..0]								R/W	
01h	GEST_ID	Gesture ID [7..0]									R
02h	TD_STATUS						Touch Points [3..0]			R	
03h	TOUCH1_XH	Event Flag				1st Touch X Position MSB [11..8]				R	
04h	TOUCH1_XL	1st Touch X Position LSB [7..0]									R
05h	TOUCH1_YH	Touch ID [3..0]					1st Touch Y Position MSB [11..8]			R	
06h	TOUCH1_YL	1st Touch Y Position LSB [7..0]									R
07h										R	
08h										R	
09h	TOUCH2_XH	Event Flag				2nd Touch X Position MSB [11..8]				R	
0Ah	TOUCH2_XL	2nd Touch X Position LSB [7..0]									R
0Bh	TOUCH2_YH	Touch ID [3..0]					2nd Touch Y Position MSB [11..8]			R	
0Ch	TOUCH2_YL	2nd Touch Y Position LSB [7..0]									R
0Dh										R	
0Eh										R	
0Fh	TOUCH3_XH	Event Flag				3rd Touch X Position MSB [11..8]				R	
10h	TOUCH3_XL	3rd Touch X Position LSB [7..0]									R
11h	TOUCH3_YH	Touch ID [3..0]					3rd Touch Y Position MSB [11..8]			R	
12h	TOUCH3_YL	3rd Touch Y Position LSB [7..0]									R
13h										R	
14h										R	
15h	TOUCH4_XH	Event Flag				4th Touch X Position MSB [11..8]				R	
16h	TOUCH4_XL	4th Touch X Position LSB [7..0]									R
17h	TOUCH4_YH	Touch ID [3..0]					4th Touch Y Position MSB [11..8]			R	
18h	TOUCH4_YL	4th Touch Y Position LSB [7..0]									R
19h										R	
1Ah										R	
1Bh	TOUCH5_XH	Event Flag				5th Touch X Position MSB [11..8]				R	
1Ch	TOUCH5_XL	5th Touch X Position LSB [7..0]									R
1Dh	TOUCH5_YH	Touch ID [3..0]					5th Touch Y Position MSB [11..8]			R	
1Eh	TOUCH5_YL	5th Touch Y Position LSB [7..0]									R
1Fh										R	

Address	Name	B7	B6	B5	B4	B3	B2	B1	B0	Access
80h	ID_G_THGROUP	valid touching detect threshold								R/W
81h	ID_G_THPEAK	valid touching peak detect threshold								R/W
82h	ID_G_THCAL	the threshold when calculating the focus of touching								R/W
83h	ID_G_THWATER	the threshold when there is surface water								R/W
84h	ID_G_TEMP	the threshold of temperature compensation								R/W
85h	ID_G_THDIFF	the threshold whether the coordinate is different from original								R/W
86h	ID_G_CTRL					Power Control Mode [1..0]				R/W
87h	ID_G_TIME_ENTER_MONITOR	the timer for entering monitor status								R/W
88h	ID_G_PERIODACTIVE					Period Active [3..0]				R/W
89h	ID_G_PERIODMONITOR	the timer of entering idle when in monitor status								R/W
A0h	ID_G_AUTO_CLB_MODE	auto calibration mode								R/W
A1h	ID_G_LIB_VERSION_H	Firmware Library Version H byte								R
A2h	ID_G_LIB_VERSION_L	Firmware Library Version L byte								R
A3h	ID_G_CIPHER	Chip vendor ID								R
A4h	ID_G_MODE	the interrupt status to host								R
A5h	ID_G_PMODE	Power Consume Mode								
A6h	ID_G_FIRMID	Firmware ID								R
A7h	ID_G_STATE	Running State								
A8h	ID_G_FT5201ID	CTPM Vendor ID								R
A9h	ID_G_ERR	Error Code								R
AAh	ID_G_CLB	Configure TP module during calibration in Test Mode								R/W
FEh	LOG_MSG_CNT	The log MSG count								R
FFh	LOG_CUR_CHA	Current character of log message								R

NOTE: Registers 80h – AFh have been configured for optimum settings and do not need to be modified.

Register No	Register Name	Bits	Value	Description
00h	Device Mode	[2:0]	000b 100b 001b	Normal Operating Mode Test Mode - read raw data (reserved) System Information Mode (reserved)
01h	Gesture ID	[7:0]	48h 49h 00h	Zoom In Zoom Out No Gesture
02h	Touch Points	[3:0]	000b 001b 010b 011b 100b 101b	0 touch points detected 1 touch point detected 2 touch points detected 3 touch points detected 4 touch points detected 5 touch points detected
03h	Touch 1 Event Flag	[7:6]	00b 01b 10b 11b	Put Down Put Up Contact Reserved
03h	TOUCH1_XH	[3:0]	0h - 1h	Upper 4 bits of X touch coordinate
04h	TOUCH1_XL	[7:0]	00h - FFh	Lower 8 bits of X touch coordinate
05h	TOUCH1_YH	[3:0]	0h - 1h	Upper 4 bits of Y touch coordinate
06h	TOUCH1_YL	[7:0]	00h - FFh	Lower 8 bits of Y touch coordinate
09h	Touch 2 Event Flag	[7:6]	00b 01b 10b 11b	Put Down Put Up Contact Reserved
09h	TOUCH2_XH	[3:0]	0h - 1h	Upper 4 bits of X touch coordinate
0Ah	TOUCH2_XL	[7:0]	00h - FFh	Lower 8 bits of X touch coordinate
0Bh	TOUCH2_YH	[3:0]	0h - 1h	Upper 4 bits of Y touch coordinate
0Ch	TOUCH2_YL	[7:0]	00h - FFh	Lower 8 bits of Y touch coordinate
0Fh	Touch 3 Event Flag	[7:6]	00b 01b 10b 11b	Put Down Put Up Contact Reserved
0Fh	TOUCH3_XH	[3:0]	0h - 1h	Upper 4 bits of X touch coordinate
10h	TOUCH3_XL	[7:0]	00h - FFh	Lower 8 bits of X touch coordinate
11h	TOUCH3_YH	[3:0]	0h - 1h	Upper 4 bits of Y touch coordinate
12h	TOUCH3_YL	[7:0]	00h - FFh	Lower 8 bits of Y touch coordinate
15h	Touch 4 Event Flag	[7:6]	00b 01b 10b 11b	Put Down Put Up Contact Reserved
15h	TOUCH4_XH	[3:0]	0h - 1h	Upper 4 bits of X touch coordinate
16h	TOUCH4_XL	[7:0]	00h - FFh	Lower 8 bits of X touch coordinate
17h	TOUCH4_YH	[3:0]	0h - 1h	Upper 4 bits of Y touch coordinate
18h	TOUCH4_YL	[7:0]	00h - FFh	Lower 8 bits of Y touch coordinate

Register No	Register Name	Bits	Value	Description
1Bh	Touch 5 Event Flag	[7:6]	00b 01b 10b 11b	Put Down Put Up Contact Reserved
1Bh	TOUCH5_XH	[3:0]	0h - 1h	Upper 4 bits of X touch coordinate
1Ch	TOUCH5_XL	[7:0]	00h - FFh	Lower 8 bits of X touch coordinate
1Dh	TOUCH5_YH	[3:0]	0h - 1h	Upper 4 bits of Y touch coordinate
1Eh	TOUCH5_YL	[7:0]	00h - FFh	Lower 8 bits of Y touch coordinate
80h	ID_G_THGROUP	[7:0]	00h - FFh	Valid touching detect threshold Actual value will be 4 times register's value Recommended: 46h
81h	ID_G_THPEAK	[7:0]	00h - FFh	valid touching peak detect threshold Recommended: 3Ch
82h	ID_G_THCAL	[7:0]	00h - FFh	Touch focus threshold Recommended: 1Dh
83h	ID_G_THWATER	[7:0]	00h - FFh	threshold when there is surface water Recommended: D3h
84h	ID_G_THTEMP	[7:0]	00h - FFh	threshold of temperature compensation Recommended: EBh
85h	ID_G_THDIFF	[7:0]	00h - FFh	Touch difference threshold Actual value is 32 times the register's value Recommended: A0h
86h	ID_G_CTRL	[1:0]	00h 01h	Power Control Mode: Not Auto Jump Power Control Mode: Auto Jump
87h	ID_G_TIME_ENTER_MONITOR	[7:0]	00h-FFh	Delay to enter 'Monitor' status (s) Recommended: C8h
88h	ID_G_PERIODACTIVE	[3:0]	3h-Eh	Period of 'Active' status (ms) Recommended: 6h
89h	ID_G_PERIODMONITOR	[7:0]	1Eh-FFh	Timer to enter 'idle' when in 'Monitor' (ms) Recommended: 28h
A0h	ID_G_AUTO_CLB_MODE	[7:0]	00h FFh	Auto calibration mode: Enable auto calibration Auto calibration mode: Disable auto calibration
A1h	ID_G_LIB_VERSION_H	[7:0]	30h	Firmware Library Version H byte
A2h	ID_G_LIB_VERSION_L	[7:0]	01h	Firmware Library Version L byte
A3h	ID_G_CIPHER	[7:0]	06h	Chip vendor ID
A4h	ID_G_MODE	[0:0]	00h 01h	Interrupt status: Enable interrupt to host Interrupt status: Disable interrupt to host
A5h	ID_G_PMODE	[1:0]	00h 01h 03h	'Active' Mode 'Monitor' Mode 'Hibernate' Mode
A6h	ID_G_FIRMID	[7:0]	30h	Firmware ID
A7h	ID_G_STATE	[7:0]	00h 01h 02h 03h 04h	Running State: Configure Running State: Work Running State: Calibration Running State: Factory Running State: Auto-calibration
A8h	ID_G_FT5201ID	[7:0]	98h	CTPM Vendor's Chip ID
A9h	ID_G_ERR	[7:0]	00h 03h 05h 1Ah	Error Code: OK Error Code: Chip register writing inconsistent with reading Error Code: Chip start fail Error Code: Calibration match fail

Timing Characteristics – TFT Display

Parameter	Symbol	Spec.			Unit
		Min.	Typ.	Max.	
HS setup time	T_{hst}	8	-	-	ns
HS hold time	T_{hhd}	8	-	-	ns
VS setup time	T_{vst}	8	-	-	ns
VS hold time	T_{vhd}	8	-	-	ns
Data setup time	T_{dsu}	8	-	-	ns
Data hold time	T_{dhd}	8	-	-	ns
DE setup time	T_{esu}	8	-	-	ns
DE hold time	T_{ehd}	8	-	-	ns
VDD Power On Slew rate	T_{POR}	-	-	20	ms
RSTB pulse width	T_{Rst}	10	-	-	us
CLKIN cycle time	T_{cph}	20	-	-	ns
CLKIN pulse duty	T_{cwh}	40	50	60	%
Output stable time	T_{sst}	-	-	6	us

Horizontal Timing

Parameter	Symbol	Spec.			Unit
		Min.	Typ.	Max.	
Horizontal Display Area	thd	800			DCLK
DCLK frequency	fclk	-	30	50	MHz
One Horizontal Line	th	889	928	1143	DCLK
HS pulse width	thpw	1	48	255	DCLK
HS Back Porch (Blanking)	thb	88			DCLK
HS Front Porch	thfp	1	40	255	DCLK
DE mode Blanking	th-thd	85	128	512	DCLK

Vertical Timing

Parameter	Symbol	Spec.			Unit
		Min.	Typ.	Max.	
Vertical Display Area	tvd	480			T_H
VS period time	tv	513	525	767	T_H
VS pulse width	tvpw	3	3	255	T_H
VS Back Porch (Blanking)	tvb	32			T_H
VS Front Porch	tvfp	1	13	255	T_H
DE mode Blanking	tv-tvd	4	45	255	T_H

Horizontal Timing

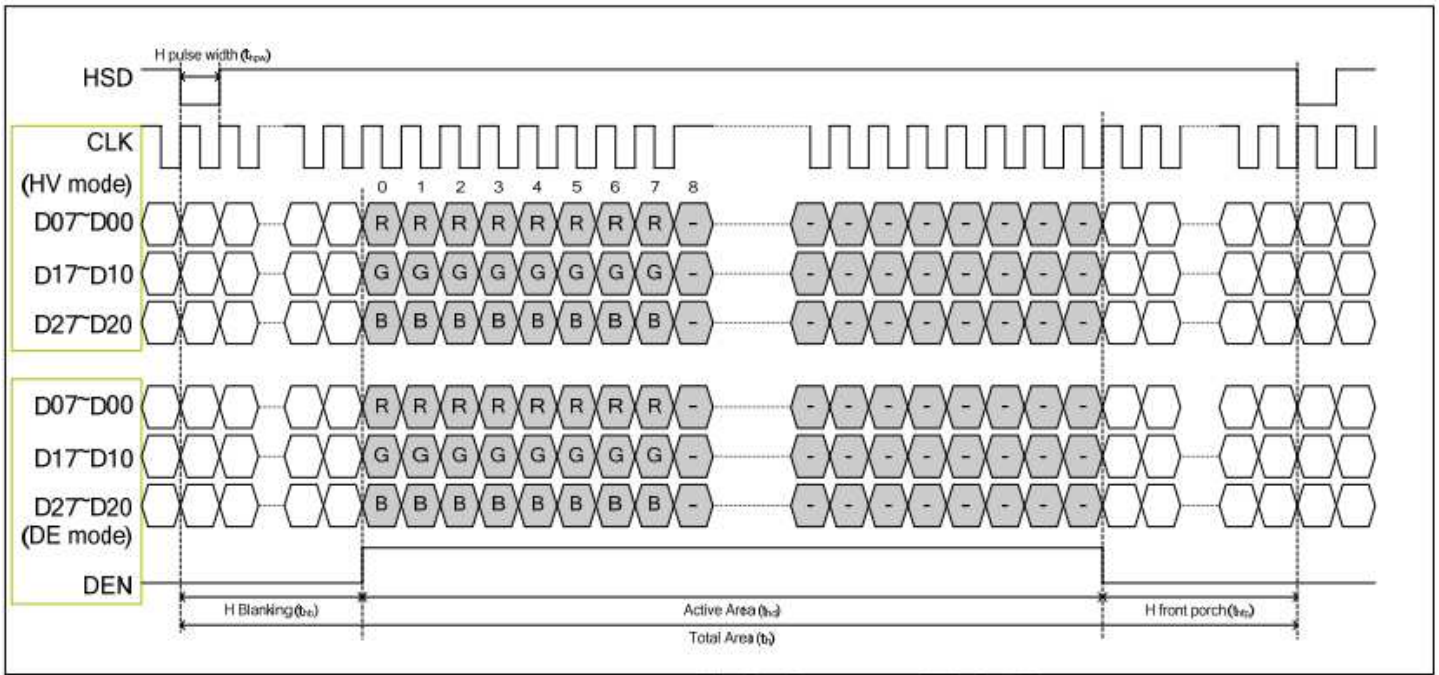

Vertical Timing

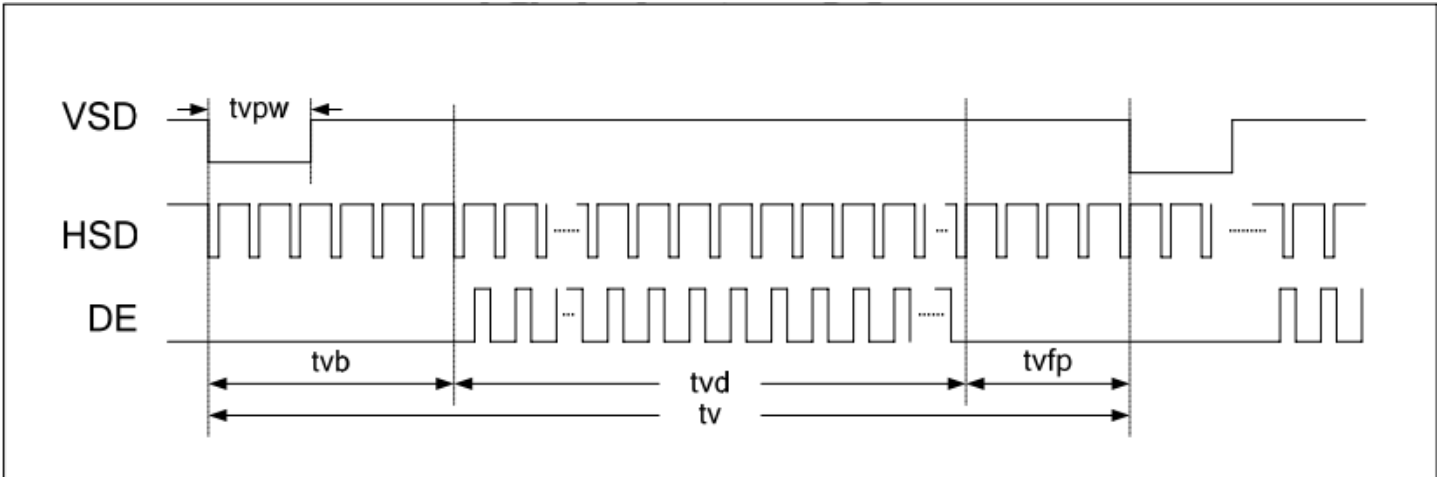

Vertical Timing HV (Cascade)

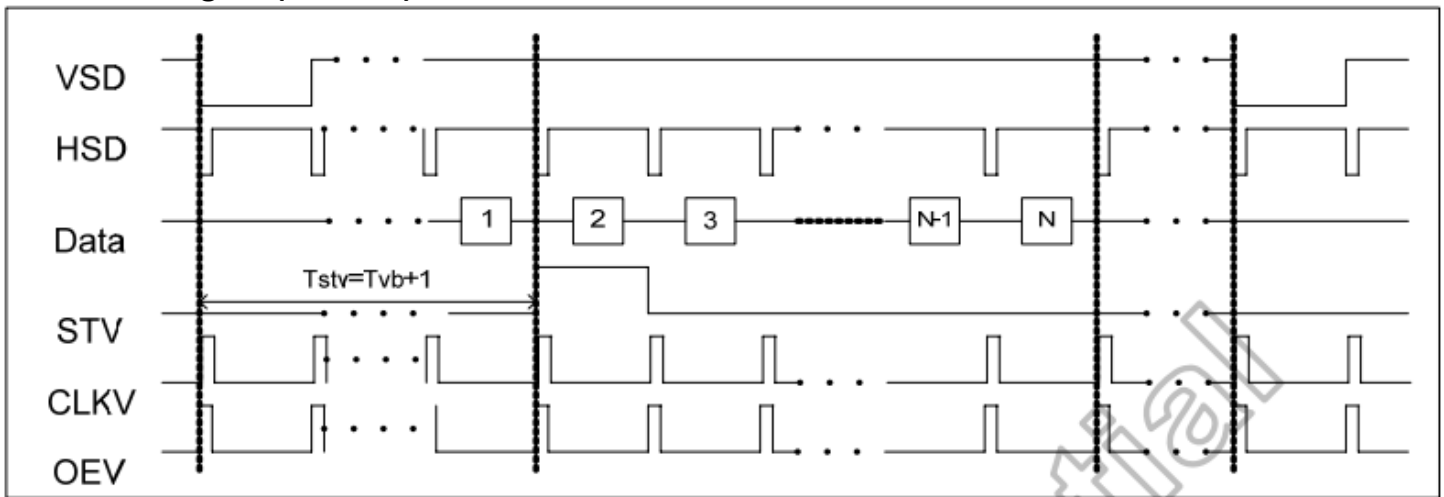

Vertical Timing DE (Cascade)

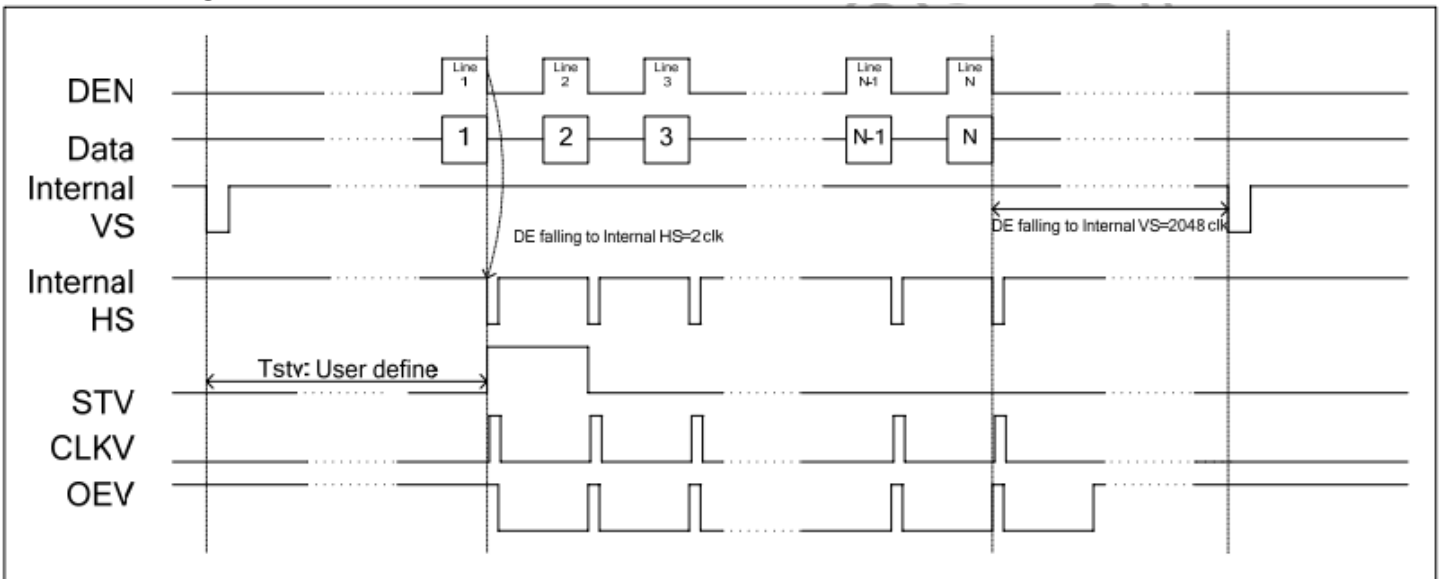

Gate Output Timing (Cascade)

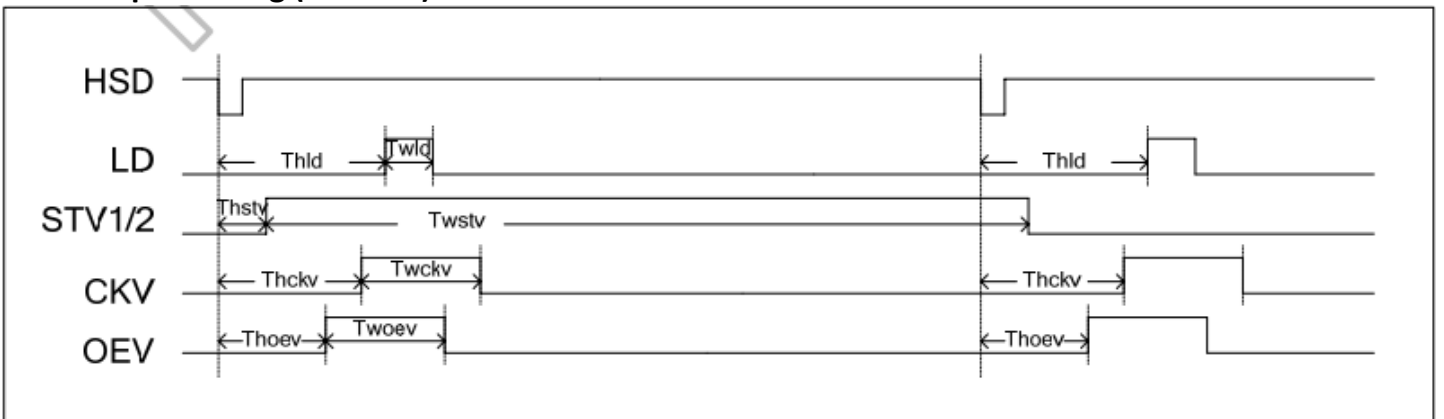

Vertical Timing HV (Dual Gate)

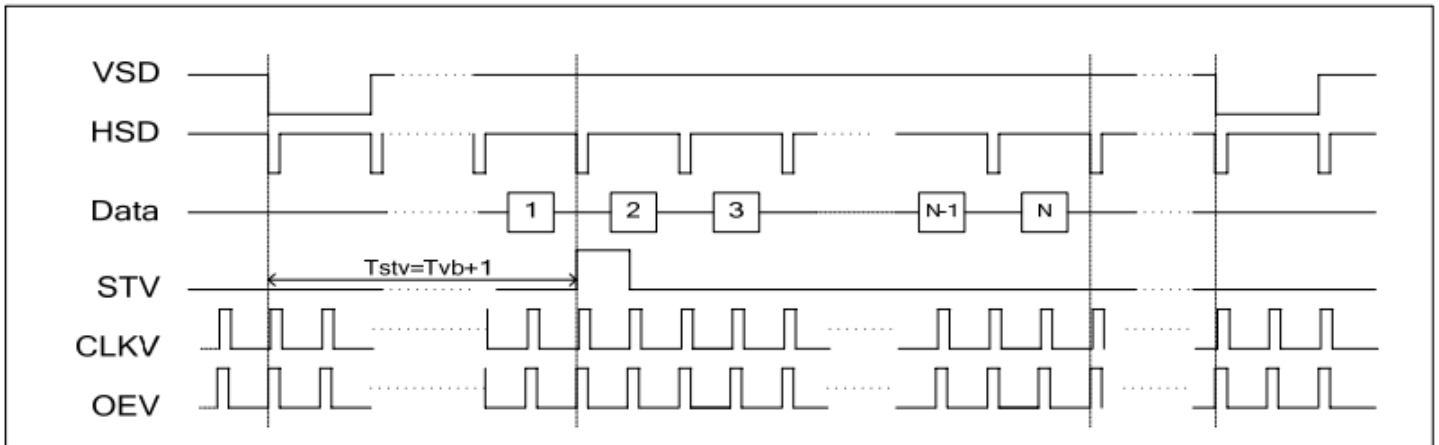

Vertical Timing DE (Dual Gate)

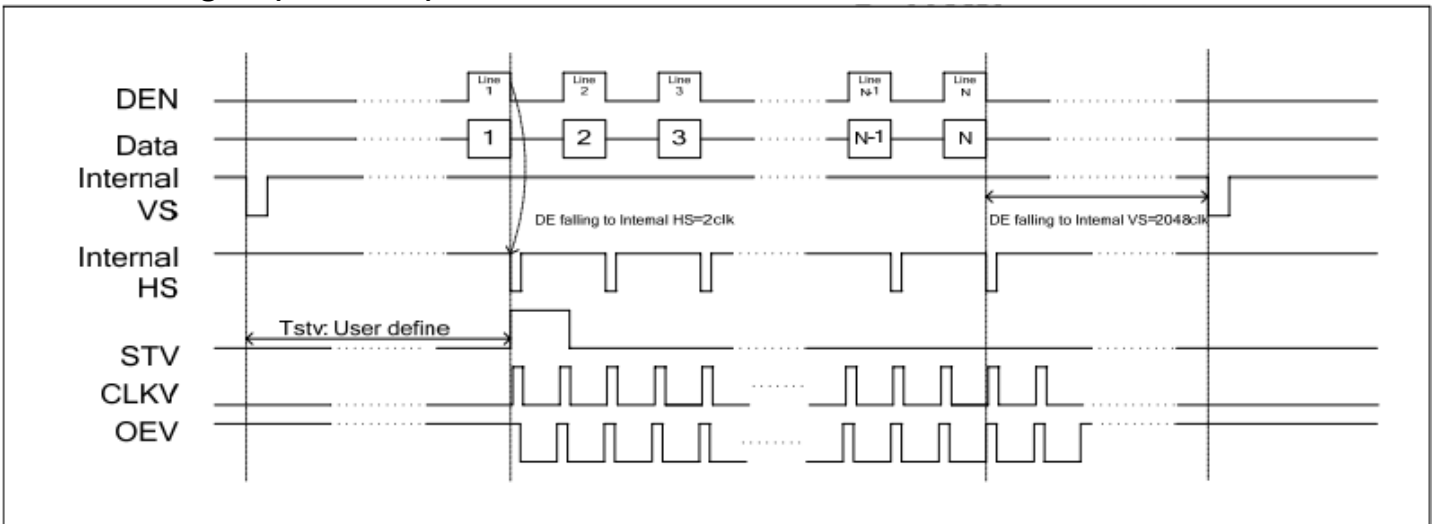

Gate Output Timing (Dual Gate)

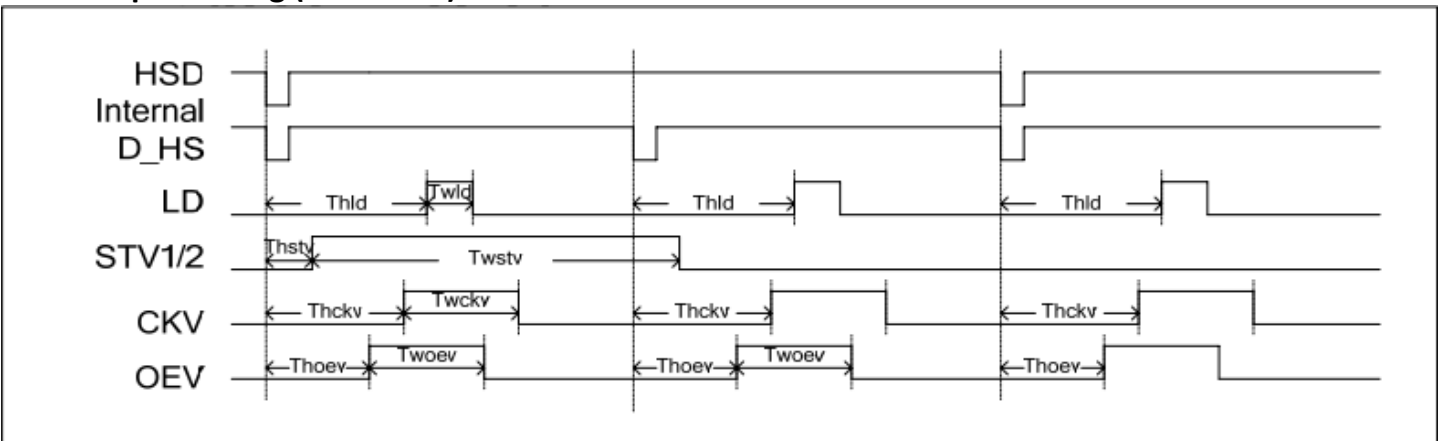

Power ON/OFF Sequence

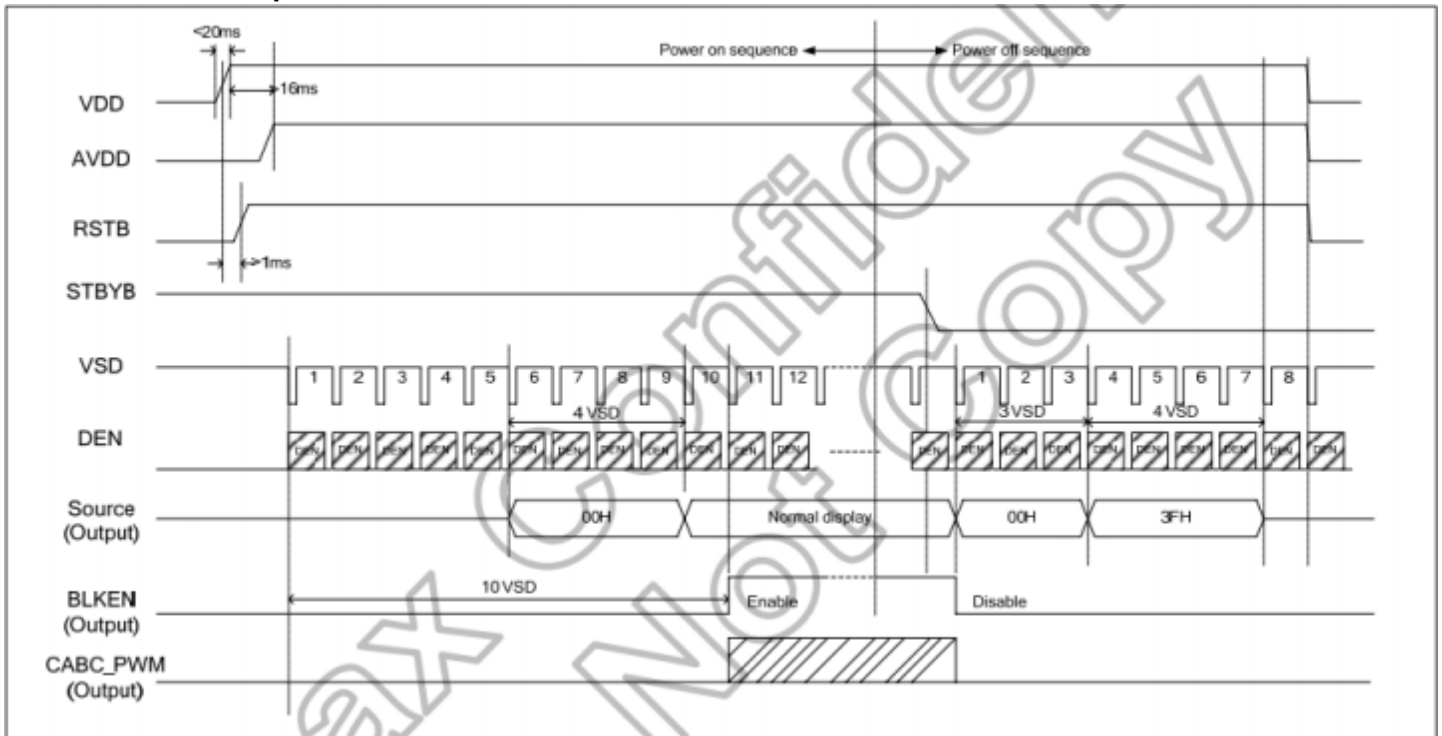

Enter/Exit Standby Mode Sequence

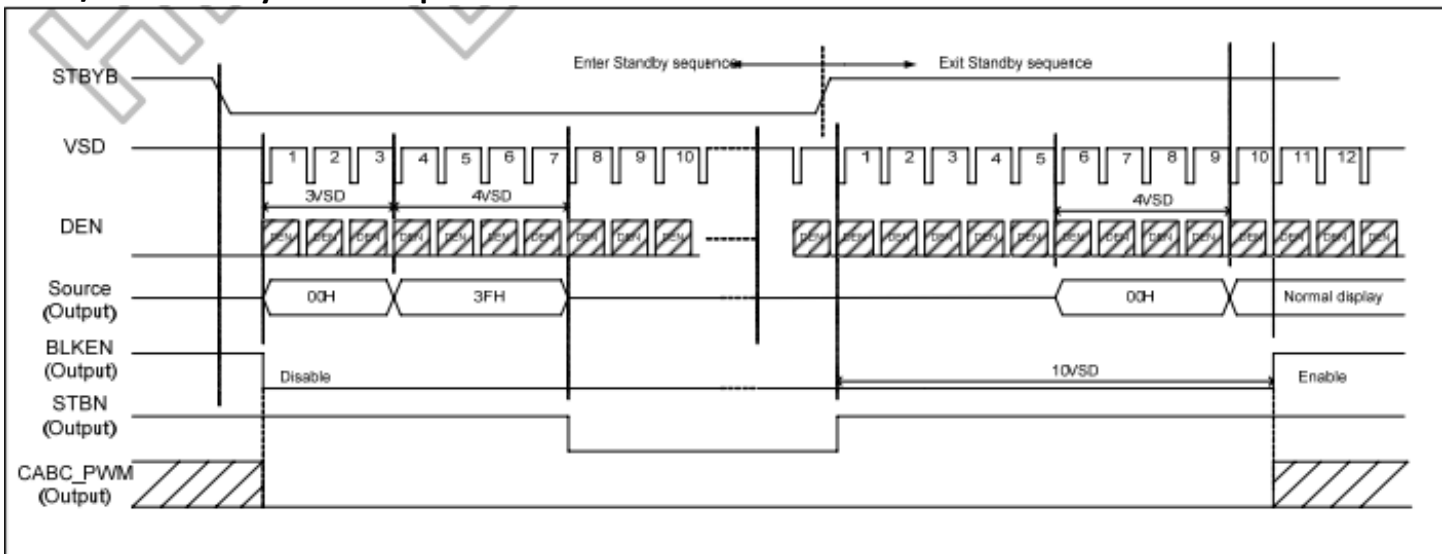

Timing Characteristics – Capacitive Touch Panel

Data Transfer Format

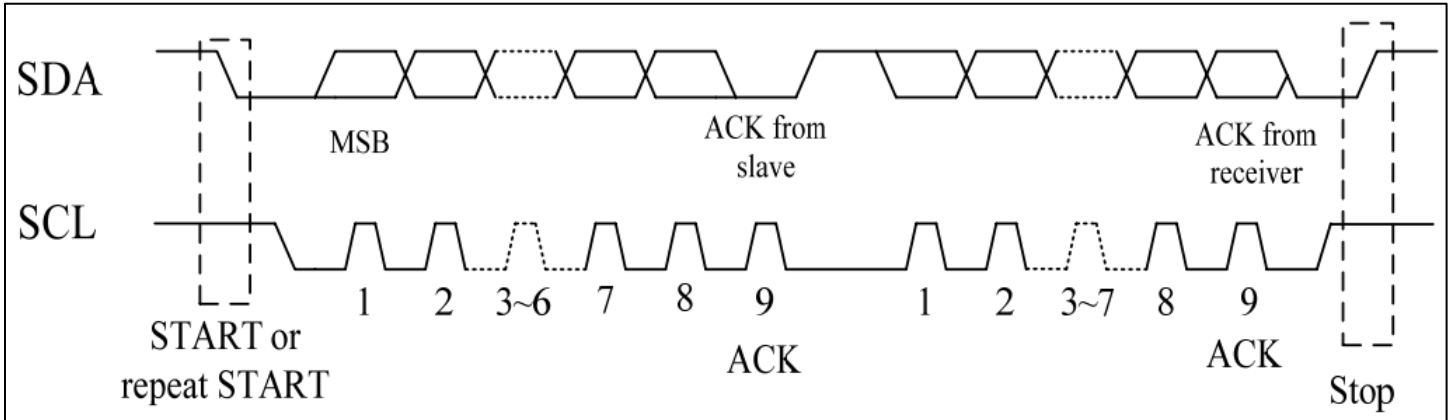

Parameter	Unit	Min	Max
SCL frequency	KHz	0	400
Bus free time between a STOP and START condition	us	4.7	\
Hold time (repeated) START condition	us	4.0	\
Data setup time	ns	250	\
Setup time for a repeated START condition	us	4.7	\
Setup Time for STOP condition	us	4.0	\

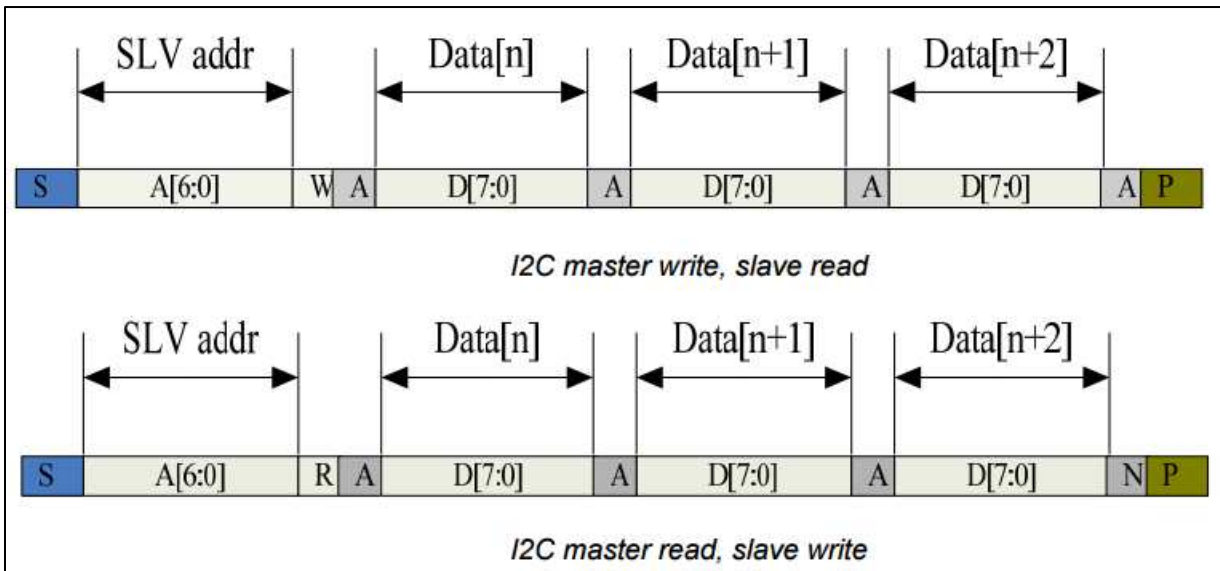

Power ON Sequence

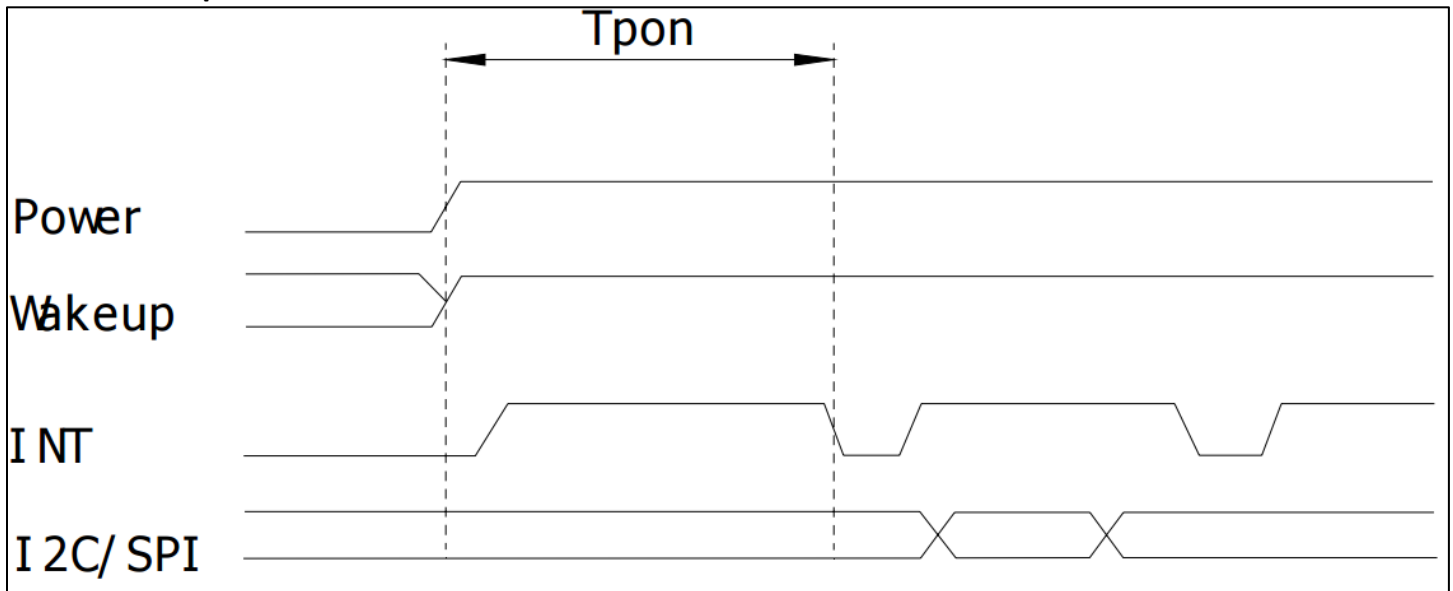

Reset Sequence

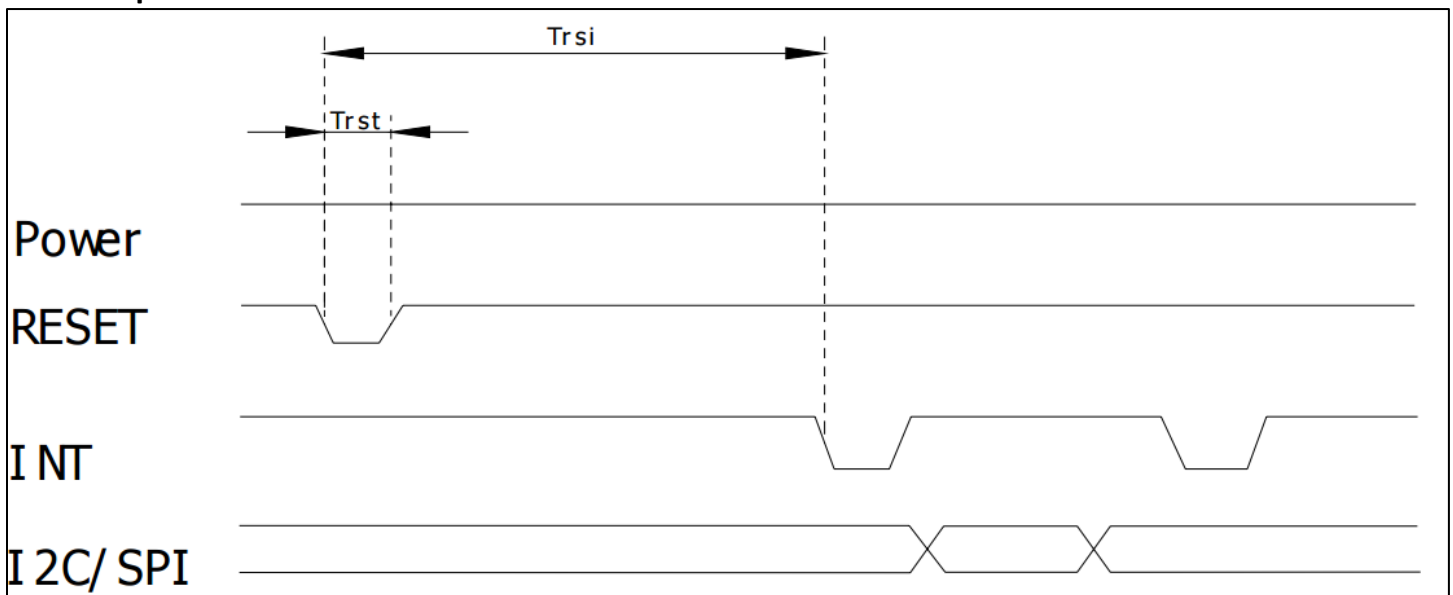

Parameter	Description	Min	Max	Units
$Tris$	Rise time from 0.1VDD to 0.9VDD	--	10	ms
T_{pon}	Time of starting to report point after powering on	300	--	ms
$Trsi$	Time of starting to report point after resetting	300	--	ms
$Trst$	Reset time	5	--	ms
T_{wai}	Time of starting to report point after waking	300	--	ms
T_{wak}	Wake up time	5	--	ms

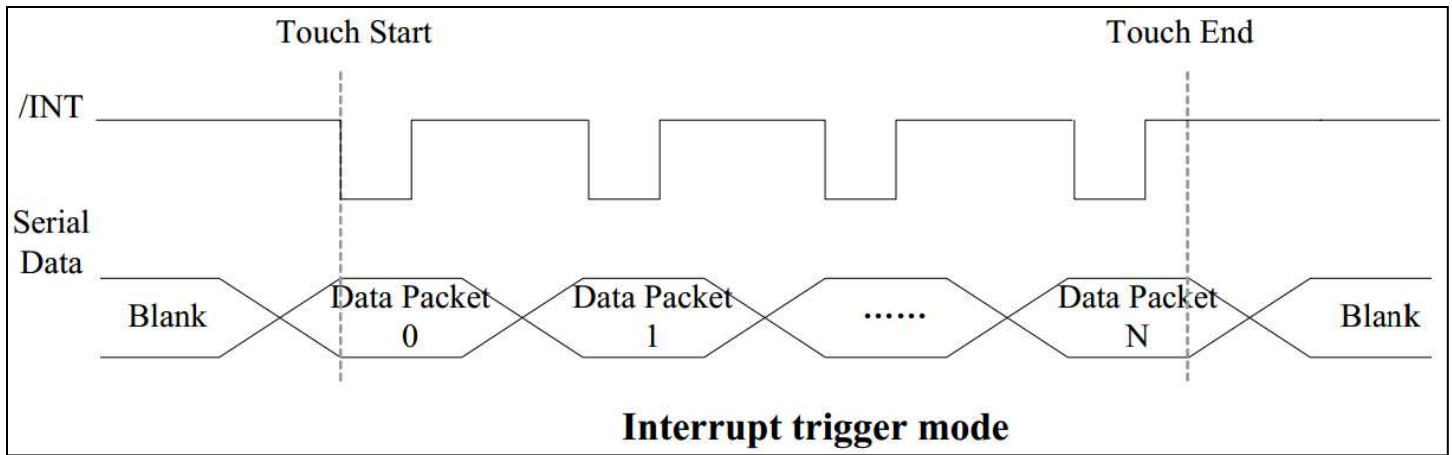

Sample code to read touch data:

```

i2c_start();
i2c_tx(0x70);           //Slave Address (Write)
i2c_tx(0x00);           //Start reading address
i2c_stop();

i2c_start();
i2c_tx(0x71);           //Slave Address (Read)
for(i=0x00;i<0x1F;i++)
{touchdata_buffer[i] = i2c_rx(1);}
i2c_stop();

```

Sample code to overwrite default register values:

```

i2c_start();
i2c_tx(0x70);           //Slave Address (Write)
i2c_tx(0xA4);           //ID_G_Mode
i2c_tx(0x01);           //Disable interrupt status to host
i2c_stop();

```

Quality Information

Test Item	Content of Test	Test Condition	Note
High Temperature storage	Endurance test applying the high storage temperature for a long time.	+80°C , 96hrs	2
Low Temperature storage	Endurance test applying the low storage temperature for a long time.	-30°C , 96hrs	1,2
High Temperature Operation	Endurance test applying the electric stress (voltage & current) and the high thermal stress for a long time.	+70°C, 96hrs	2
Low Temperature Operation	Endurance test applying the electric stress (voltage & current) and the low thermal stress for a long time.	-20°C , 96hrs	1,2
High Temperature / Humidity Operation	Endurance test applying the electric stress (voltage & current) and the high thermal with high humidity stress for a long time.	+50°C , 90% RH , 96hrs	1,2
Thermal Shock resistance	Endurance test applying the electric stress (voltage & current) during a cycle of low and high thermal stress.	-30°C, 30min -> 80°C, 30min, Change time: 5min, 10 cycles	
Vibration test	Endurance test applying vibration to simulate transportation and use.	10-55Hz , 1.5mm amplitude. 60 sec in each of 3 directions X,Y,Z For 15 minutes	3
Static electricity test	Endurance test applying electric static discharge.	VS=800V, RS=1.5kΩ, CS=100pF One time	

Note 1: No condensation to be observed.

Note 2: Conducted after 4 hours of storage at 25°C, 0%RH.

Note 3: Test performed on product itself, not inside a container.

Precautions for using LCDs/LCMs

See Precautions at www.newhavendisplay.com/specs/precautions.pdf

Warranty Information and Terms & Conditions

http://www.newhavendisplay.com/index.php?main_page=terms