



Chipsmall Limited consists of a professional team with an average of over 10 year of expertise in the distribution of electronic components. Based in Hongkong, we have already established firm and mutual-benefit business relationships with customers from,Europe,America and south Asia,supplying obsolete and hard-to-find components to meet their specific needs.

With the principle of “Quality Parts,Customers Priority,Honest Operation,and Considerate Service”,our business mainly focus on the distribution of electronic components. Line cards we deal with include Microchip,ALPS,ROHM,Xilinx,Pulse,ON,Everlight and Freescale. Main products comprise IC,Modules,Potentiometer,IC Socket,Relay,Connector.Our parts cover such applications as commercial,industrial, and automotives areas.

We are looking forward to setting up business relationship with you and hope to provide you with the best service and solution. Let us make a better world for our industry!



Contact us

Tel: +86-755-8981 8866 Fax: +86-755-8427 6832

Email & Skype: info@chipsmall.com Web: www.chipsmall.com

Address: A1208, Overseas Decoration Building, #122 Zhenhua RD., Futian, Shenzhen, China



NHD-7.0-800480WF-CTXI#-T

TFT (Thin-Film-Transistor) Color Liquid Crystal Display Module

NHD-	Newhaven Display
7.0-	7.0" Diagonal
800480-	800xRGBx480 pixels
WF-	Model
C-	Built-in Controller
T-	White LED backlight
X-	TFT
I-	6:00 view, Wide Temp
#-	RoHS Compliant
T-	Touch Panel

Newhaven Display International, Inc.

2511 Technology Drive, Suite 101

Elgin IL, 60124

Ph: 847-844-8795

Fax: 847-844-8796

www.newhavendisplay.com

nhtech@newhavendisplay.com

nhsales@newhavendisplay.com

Document Revision History

Revision	Date	Description	Changed by
0	8/31/2010	Initial Release	MC
1	10/5/2010	Mechanical Drawing updated	BE
2	2/8/2011	Initialization code added	AK
3	2/23/2011	Grammar/symbols updated	BE
4	10/7/2011	Backlight and Touch Panel pin descriptions added	AK
5	1/6/2012	Pixel data format updated	AK

Functions and Features

- 800xRGBx480 resolution
- LED backlight
- 8-bit digital RGB interface
- 262,144 colors
- SSD1963 8-bit controller

Mechanical Drawing

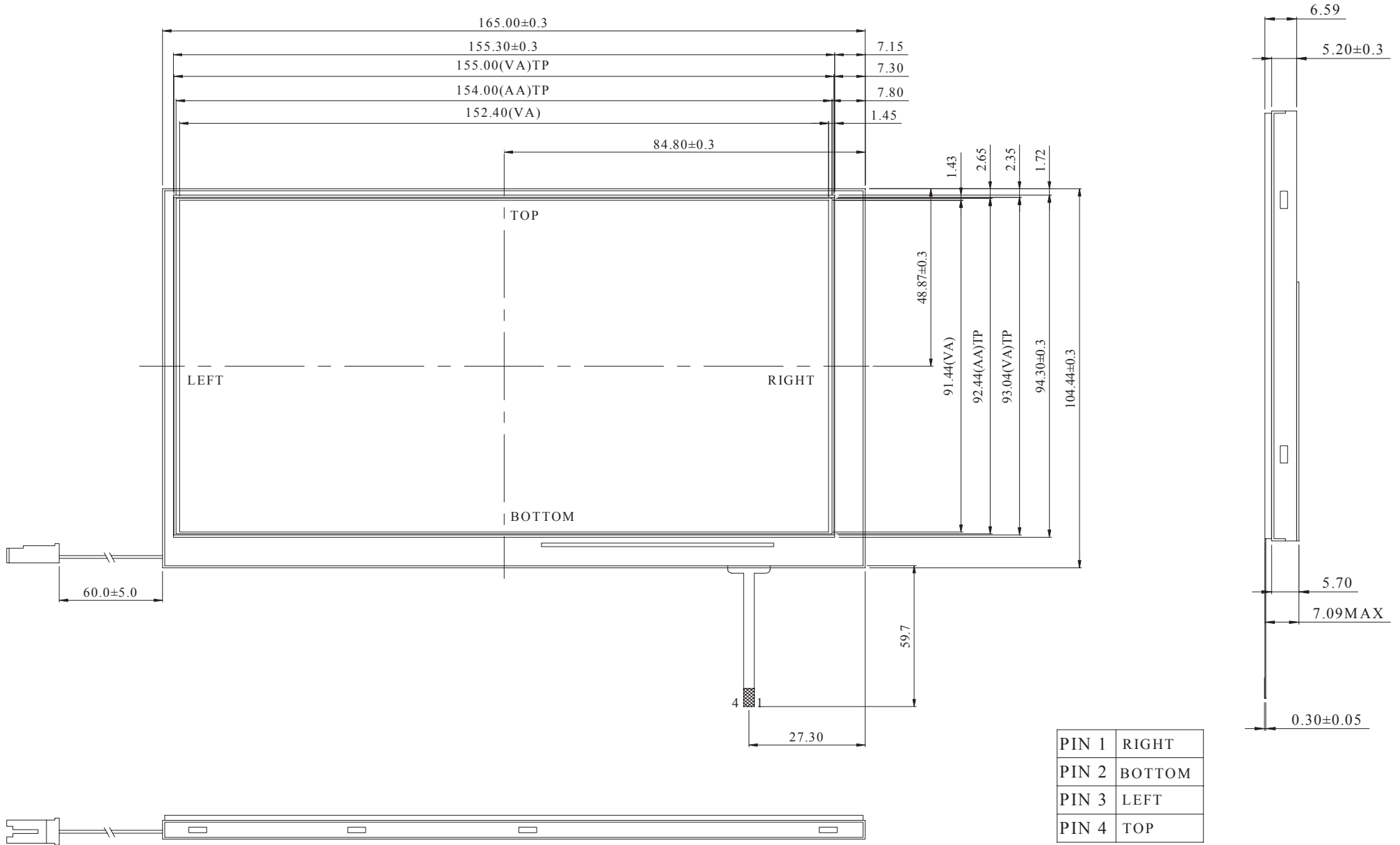

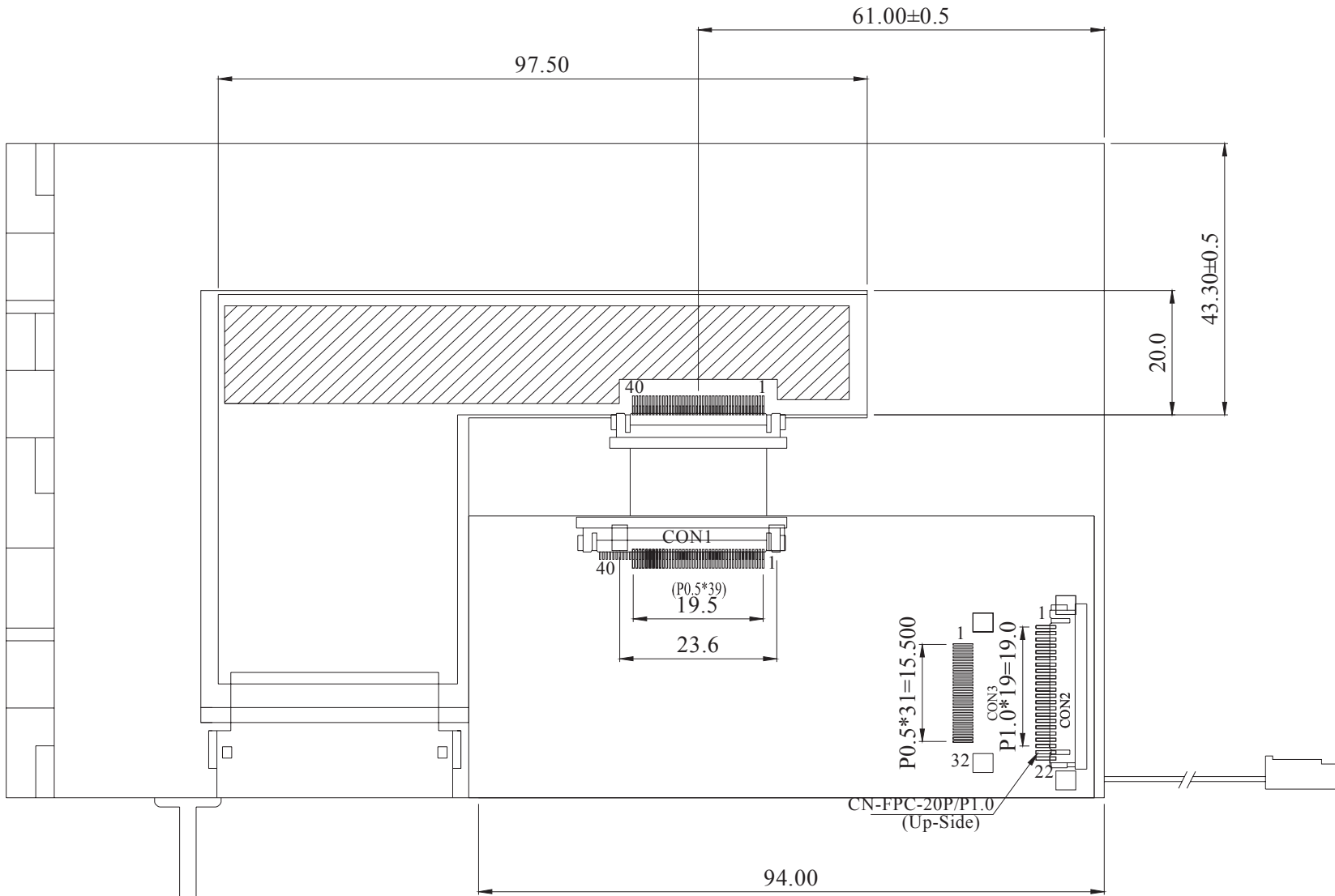

PIN NO.	SYMBOL
1	GND
2	VDD
3	VO
4	A0
5	R/W
6	E
7	DB0
8	DB1
9	DB2
10	DB3
11	DB4
12	DB5
13	DB6
14	DB7
15	CS
16	NC
17	NC
18	RST
19	NC
20	NC

CON2 LCD Pin Description

Pin No.	Symbol	Connection	Function Description
1	GND	Power Supply	Ground
2	VDD	Power Supply	Power supply for logic (+3.3V)
3	NC	-	No Connect
4	D/C#	MPU	Register Select signal: 1=Data, 0=Command
5	WR#	MPU	Active LOW Write signal (8080 mode) Read/Write signal (6800 mode)
6	RD#	MPU	Active LOW Read signal (8080 mode) Edge trigger Enable signal (6800 mode)
7-14	DB0~DB7	MPU	8-bit bi-directional data bus
15	CS#	MPU	Active LOW Chip Select signal
16	NC	-	No Connect
17	NC	-	No Connect
18	RST#	MPU	Active LOW Reset signal
19	NC	-	No Connect
20	NC	-	No Connect

LCD connector: 1.0mm pitch,20-Conductor FFC, top contact

Recommended connection: 1.0mm pitch, 20-conductor FFC cable

CON1 TFT Pin-Out (before controller board):

Pin No.	Symbol	Connection	Function Description
1	GND	Power Supply	Power Ground
2	GND	Power Supply	Power Ground
3	NC	-	No connect
4-7	VDD	Power Supply	Power Supply (+3.3V)
8	NC	-	No connect
9	DE	MPU	Data Enable
10-12	GND	Power Supply	Power Ground
13-15	B5-B3	MPU	Blue B5 (MSB) to B3
16	GND	Power Supply	Power Ground
17-19	B2-B0	MPU	Blue B2 – B0(LSB)
20	GND	Power Supply	Power Ground
21-23	G5-G3	MPU	Green B5 (MSB) to B3
24	GND	Power Supply	Power Ground
25-27	G2-G0	MPU	Green B2 – B0(LSB)
28	GND	Power Supply	Power Ground
29-31	R5-R3	MPU	Red B5 (MSB) to B3
32	GND	Power Supply	Power Ground
33-35	R2-R0	MPU	Red B2 – B0(LSB)
36-37	GND	Power Supply	Power Ground
38	DCLK	MPU	Clock (Falling edge triggered)
39-40	GND	Power Supply	Power Ground

LCD connector: 0.5mm pitch,40-Conductor FFC, Bottom contact

Recommended connection: 0.5mm pitch, 40-conductor FFC cable

Backlight Pin-Out:

Pin No.	Symbol	Connection	Function Description
1	VDD	Power Supply	Power Supply (+9.9V)
2	GND	Power Supply	Power Ground

Backlight connector: JST p/n: BHSR-02VS-1

Recommended mating connector: JST p/n: SM 02B-BHSS-1

Touch Panel Pin-Out:

Pin No.	Symbol	Connection	Function Description
1	X-	Touch Panel	Touch Panel – RIGHT
2	Y-	Touch Panel	Touch Panel – BOTTOM
3	X+	Touch Panel	Touch Panel – LEFT
4	Y+	Touch Panel	Touch Panel – TOP

Touch Panel Characteristics

Item	Min.	Typ.	Max.	Unit
Linearity	-	-	1.5	%
Circuit Resistance – X-Axis	450	800	1300	Ω
Circuit Resistance – Y-Axis	100	350	800	Ω
Insulation Resistance	10	-	-	M Ω
Operating Voltage	-	-	5	V
Chattering	-	-	10	ms
Transmittance	82	-	-	%
Activation Force	50	-	200	g
Pen Writing Durability	100,000	-	-	Characters
Pitting Durability	1,000,000	-	-	Touches
Surface Hardness	3	-	-	H
Haze	-	7	-	%

Electrical Characteristics

Item	Symbol	Condition	Min.	Typ.	Max.	Unit
Operating Temperature Range	Top	Absolute Max	-20	-	+70	$^{\circ}\text{C}$
Storage Temperature Range	Tst	Absolute Max	-30	-	+80	$^{\circ}\text{C}$
Supply Voltage	VDD		3.0	3.3	3.5	V
Supply Current	IDD	VDD=3.3V 25 $^{\circ}\text{C}$	-	200	260	mA
“H” Level input	Vih		0.8VDD	-	VDD+ 0.5	V
“L” Level input	Vil		-	-	0.2VDD	V
Backlight Supply Voltage	VLED		-	9.9	-	V
Backlight Supply Current	ILED	VLED=9.9V	140	160	180	mA
Backlight Lifetime	-	Until half-brightness	10,000	20,000	-	Hrs.

Optical Characteristics

Item	Symbol	Condition	Min.	Typ.	Max.	Unit
Viewing Angle –Vertical (Top)	AV	Cr \geq 10	50	60	-	$^{\circ}$
Viewing Angle –Vertical (Bottom)	AV	Cr \geq 10	60	70	-	$^{\circ}$
Viewing Angle – Horizontal (Left)	AH	Cr \geq 10	60	70	-	$^{\circ}$
Viewing Angle – Horizontal (Right)	AH	Cr \geq 10	60	70	-	$^{\circ}$
Contrast Ratio	Cr	-	250	400	-	-
Luminance	YL	-	300	350	-	cd/m 2
Response Time (rise)	Tr	-	-	5	10	ms
Response Time (fall)	Tf	-	-	11	16	ms

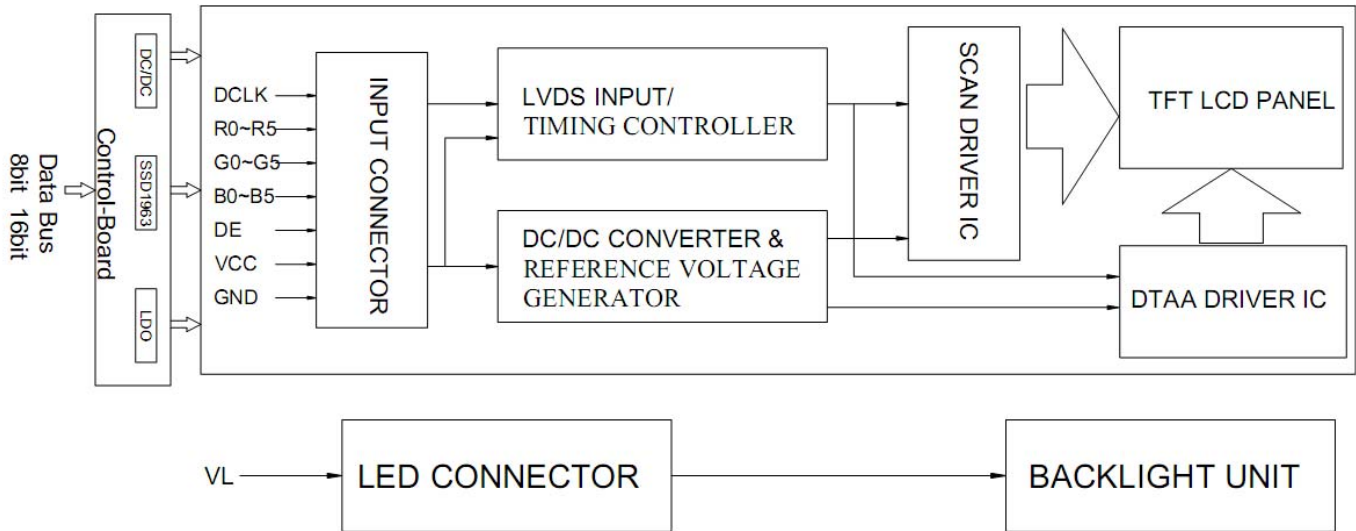

Controller Information

Built-in SSD1963 controller.

Please download specification at http://www.newhavendisplay.com/app_notes/SSD1963.pdf

Parallel Interface:

The SSD1963 controller supports both 8080 mode and 6800 mode.

See the SSD1963 datasheet for detailed timing diagrams.

Command Instructions:

See the SSD1963 datasheet for the Instruction Table and Command Descriptions.

Pixel Data Format:

Interface	Cycle	D[7]	D[6]	D[5]	D[4]	D[3]	D[2]	D[1]	D[0]
8 bits	1 st	R7	R6	R5	R4	R3	R2	R1	R0
	2 nd	G7	G6	G5	G4	G3	G2	G1	G0
	3 rd	B7	B6	B5	B4	B3	B2	B1	B0

Example Initialization Code

```
/******  
* Function Name : UILCD_Init  
* Description  : Initializes LCD.  
* Input       : None  
* Output      : None  
* Return      : None  
*****/  
void TFT_7_Init(void)  
{  
    GPIO_ResetBits(GPIOC, CS1);  
    GPIO_SetBits(GPIOC, nRD);  
    GPIO_ResetBits(GPIOC, nWR);  
    GPIO_WriteBit(GPIOC, RES, Bit_RESET);  
    TFT_delay(5);  
    GPIO_WriteBit(GPIOC, RES, Bit_SET);  
    TFT_delay(100);  
    TFT_7_Write_Command(0x01); //Software Reset  
    TFT_7_Write_Command(0x01);  
    TFT_7_Write_Command(0x01);  
    TFT_delay(10);  
    TFT_7_Command_Write(0xe0,0x01); //START PLL  
    TFT_7_Command_Write(0xe0,0x03); //LOCK PLL  
    TFT_7_Write_Command(0xb0); //SET LCD MODE SET TFT 18Bits MODE  
    GPIO_SetBits(GPIOC, RS);  
    TFT_7_Write_Data(0x08); //SET TFT MODE & hsync+Vsync+DEN MODE  
    TFT_7_Write_Data(0x80); //SET TFT MODE & hsync+Vsync+DEN MODE  
    TFT_7_Write_Data(0x03); //SET horizontal size=800-1 HighByte  
    TFT_7_Write_Data(0x1f); //SET horizontal size=800-1 LowByte  
    TFT_7_Write_Data(0x01); //SET vertical size=480-1 HighByte  
    TFT_7_Write_Data(0xdf); //SET vertical size=480-1 LowByte  
    TFT_7_Write_Data(0x00); //SET even/odd line RGB seq.=RGB  
    TFT_7_Command_Write(0xf0,0x00); //SET pixel data I/F format=8bit  
    TFT_7_Command_Write(0x36,0x09); //SET address mode=flip vertical, BGR  
    TFT_7_Command_Write(0x3a,0x60); //SET R G B format = 6 6 6  
    TFT_7_Write_Command(0xe2); //SET PLL freq=113.33MHz  
    GPIO_SetBits(GPIOC, RS);  
    TFT_7_Write_Data(0x22);  
    TFT_7_Write_Data(0x03);  
    TFT_7_Write_Data(0x04);  
    TFT_7_Write_Command(0xe6); //SET PCLK freq=33.26MHz  
    GPIO_SetBits(GPIOC, RS);  
    TFT_7_Write_Data(0x02);  
    TFT_7_Write_Data(0xff);  
    TFT_7_Write_Data(0xff);  
    TFT_7_Write_Command(0xb4); //SET HBP,  
    GPIO_SetBits(GPIOC, RS);  
    TFT_7_Write_Data(0x03); //SET HSYNC Total  
    TFT_7_Write_Data(0xef);  
    TFT_7_Write_Data(0x00); //SET HBP  
    TFT_7_Write_Data(0xa3);  
    TFT_7_Write_Data(0x07); //SET VBP  
    TFT_7_Write_Data(0x00); //SET Hsync pulse start position  
    TFT_7_Write_Data(0x00);  
    TFT_7_Write_Data(0x00); //SET Hsync pulse subpixel start position  
    TFT_7_Write_Command(0xb6); //SET VBP,
```

```

GPIO_SetBits(GPIOC, RS);
TFT_7_Write_Data(0x01);           //SET Vsync total = 496
TFT_7_Write_Data(0xef);
TFT_7_Write_Data(0x00);           //SET VBP=4
TFT_7_Write_Data(0x04);
TFT_7_Write_Data(0x01);           //SET Vsync pulse 2=1+1
TFT_7_Write_Data(0x00);           //SET Vsync pulse start position
TFT_7_Write_Data(0x00);
TFT_7_Write_Command(0x2a);        //SET column address
GPIO_SetBits(GPIOC, RS);
TFT_7_Write_Data(0x00);           //SET start column address=0
TFT_7_Write_Data(0x00);
TFT_7_Write_Data(0x03);           //SET end column address=799
TFT_7_Write_Data(0x1f);
TFT_7_Write_Command(0x2b);        //SET page address
GPIO_SetBits(GPIOC, RS);
TFT_7_Write_Data(0x00);           //SET start page address=0
TFT_7_Write_Data(0x00);
TFT_7_Write_Data(0x01);           //SET end page address=479
TFT_7_Write_Data(0xdf);
/*TFT_7_Write_Command(0x33);      //SET scroll area
GPIO_SetBits(GPIOC, RS);
TFT_7_Write_Data(0x00);           //SET top fixed area=0
TFT_7_Write_Data(0x00);
TFT_7_Write_Data(0x01);           //SET vertical scrolling area=479
TFT_7_Write_Data(0xdf);
TFT_7_Write_Data(0x00);           //SET bottom fixed area=0
TFT_7_Write_Data(0x00);
TFT_7_Write_Command(0x28);        //SET display off */
}

```

```
void TFT_7_Write_Command(unsigned char command)
```

```

{
GPIO_Write(GPIOB, command);
GPIO_ResetBits(GPIOC, RS);
GPIO_ResetBits(GPIOC, nWR);
GPIO_SetBits(GPIOC, nWR);
}

```

```
void TFT_7_Write_Data(unsigned char data1)
```

```

{
GPIO_SetBits(GPIOC, RS);
GPIO_Write(GPIOB, data1);
GPIO_ResetBits(GPIOC, nWR);
GPIO_SetBits(GPIOC, nWR);
}

```

```
void TFT_7_Command_Write(unsigned char REG,unsigned char VALUE)
```

```

{
TFT_7_Write_Command(REG);
TFT_7_Write_Data(VALUE);
}

```

```
void TFT_7_SendData(unsigned long color)
```

```

{
GPIO_SetBits(GPIOC, RS);
GPIO_Write(GPIOB, (color>>16));
GPIO_ResetBits(GPIOC, nWR);
}

```

```
GPIO_SetBits(GPIOC, nWR);
GPIO_Write(GPIOB, (color>>8));
GPIO_ResetBits(GPIOC, nWR);
GPIO_SetBits(GPIOC, nWR);
GPIO_Write(GPIOB, (color));
GPIO_ResetBits(GPIOC, nWR);
GPIO_SetBits(GPIOC, nWR);
}
```

```
void TFT_7_WindowSet(unsigned int s_x,unsigned int e_x,unsigned int s_y,unsigned int e_y)
```

```
{
TFT_7_Write_Command(0x2a);           //SET page address
TFT_7_Write_Data((s_x)>>8);          //SET start page address=0
TFT_7_Write_Data(s_x);
TFT_7_Write_Data((e_x)>>8);          //SET end page address=639
TFT_7_Write_Data(e_x);

TFT_7_Write_Command(0x2b);           //SET column address
TFT_7_Write_Data((s_y)>>8);          //SET start column address=0
TFT_7_Write_Data(s_y);
TFT_7_Write_Data((e_y)>>8);          //SET end column address=479
TFT_7_Write_Data(e_y);
}
```

Quality Information

Test Item	Content of Test	Test Condition	Note
High Temperature storage	Endurance test applying the high storage temperature for a long time.	+80°C , 240hrs	2
Low Temperature storage	Endurance test applying the low storage temperature for a long time.	-30°C , 240hrs	1,2
High Temperature Operation	Endurance test applying the electric stress (voltage & current) and the high thermal stress for a long time.	+70°C 240hrs	2
Low Temperature Operation	Endurance test applying the electric stress (voltage & current) and the low thermal stress for a long time.	-20°C , 240hrs	1,2
High Temperature / Humidity Operation	Endurance test applying the electric stress (voltage & current) and the high thermal with high humidity stress for a long time.	+60°C , 90% RH , 240hrs	1,2
Thermal Shock resistance	Endurance test applying the electric stress (voltage & current) during a cycle of low and high thermal stress.	-30°C,30min -> 25°C,5min ->80°C,30min = 1 cycle 10 cycles	
Vibration test	Endurance test applying vibration to simulate transportation and use.	10-55Hz , 15mm amplitude. 60 sec in each of 3 directions X,Y,Z For 15 minutes	3
Static electricity test	Endurance test applying electric static discharge.	VS=800V, RS=1.5kΩ, CS=100pF One time	

Note 1: No condensation to be observed.

Note 2: Conducted after 4 hours of storage at 25°C, 0%RH.

Note 3: Test performed on product itself, not inside a container.

Precautions for using LCDs/LCMs

See Precautions at www.newhavendisplay.com/specs/precautions.pdf

Warranty Information and Terms & Conditions

http://www.newhavendisplay.com/index.php?main_page=terms