



Chipsmall Limited consists of a professional team with an average of over 10 year of expertise in the distribution of electronic components. Based in Hongkong, we have already established firm and mutual-benefit business relationships with customers from,Europe,America and south Asia,supplying obsolete and hard-to-find components to meet their specific needs.

With the principle of “Quality Parts,Customers Priority,Honest Operation,and Considerate Service”,our business mainly focus on the distribution of electronic components. Line cards we deal with include Microchip,ALPS,ROHM,Xilinx,Pulse,ON,Everlight and Freescale. Main products comprise IC,Modules,Potentiometer,IC Socket,Relay,Connector.Our parts cover such applications as commercial,industrial, and automotives areas.

We are looking forward to setting up business relationship with you and hope to provide you with the best service and solution. Let us make a better world for our industry!



## Contact us

Tel: +86-755-8981 8866 Fax: +86-755-8427 6832

Email & Skype: info@chipsmall.com Web: www.chipsmall.com

Address: A1208, Overseas Decoration Building, #122 Zhenhua RD., Futian, Shenzhen, China



# NHD-C0216CiZ-FN-FBW-3V

## COG (Chip-on-Glass) Liquid Crystal Display Module

NHD- Newhaven Display  
C0216- COG, 2 lines x 16 characters  
CiZ- Model  
F- Transflective  
N- No LED Backlight  
F- FSTN (+)  
B- 6:00 View Angle  
W- Wide Temp (-20 c ~ +70 c)  
3V- 3 Volt  
**RoHS Compliant**

**Newhaven Display International, Inc.**

2511 Technology Drive, Suite 101

Elgin IL, 60124

Ph: 847-844-8795

Fax: 847-844-8796

[www.newhavendisplay.com](http://www.newhavendisplay.com)

[nhtech@newhavendisplay.com](mailto:nhtech@newhavendisplay.com)

[nhsales@newhavendisplay.com](mailto:nhsales@newhavendisplay.com)

## Document Revision History

Revision	Date	Description	Changed by
0	3/10/2000	Initial Release	
1	5/14/2009	User guide reformat	BE
2	10/9/2009	Updated Electrical Characteristics	MC
3	11/5/2009	Block Diagram Update	BE
4	2/12/2010	Update font table	MC
5	11/2/2010	Slave address corrected	SB
6	3/30/2012	Example initialization program updated	AK

## Functions and Features

- 2 lines x 16 characters
- Built-in ST7032i-oD with I<sup>2</sup>C interface
- Built-in DC supply for VLCD (requires 2 external capacitors)
- 5x8 dots with cursor
- 3.0V power supply
- 1/16 duty, 1/5 bias
- RoHS Compliant



## Pin Description and Wiring Diagram

Pin No.	Symbol	External Connection	Function Description
1	RST	MPU	Active low Reset
2	SCL	MPU	Serial clock (requires pull-up resistor)
3	SDA	MPU	Serial Data (requires pull-up resistor)
4	Vss	Power Supply	Ground
5	VDD	Power Supply	+3.0V
6	VOOUT	CAP	Voltage booster circuit– connect to 1uF cap to Vss or VDD
7	C1+	CAP	Connect to 1uF cap to PIN8
8	C1-	CAP	Connect to 1uF cap to PIN7

**Recommended LCD connector:** 1.5mm pitch pins

**Backlight connector:** - Mates with: -

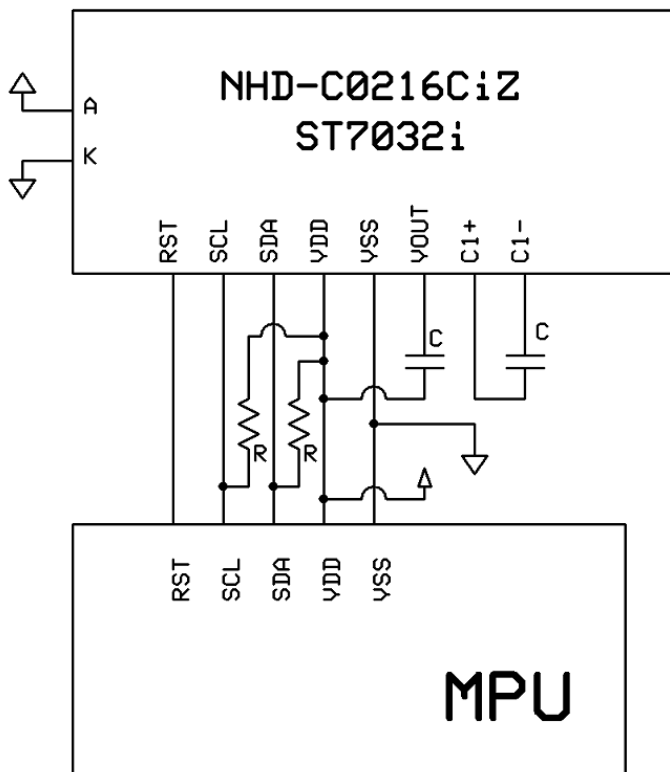

## Electrical Characteristics

Item	Symbol	Condition	Min.	Typ.	Max.	Unit
Operating Temperature Range	Top	Absolute Max	-20	-	+70	°C
Storage Temperature Range	Tst	Absolute Max	-30	-	+80	°C
Supply Voltage	VDD		2.7	3.0	3.3	V
Supply Current	IDD	Ta=25°C, VDD=3.0V	-	0.3	0.5	mA
Supply for LCD (contrast)	VDD-Vo	<b>Ta=25°C</b>	-	5.0	-	V
"H" Level input	VIH		2.2	-	VDD	V
"L" Level input	VIL		0	-	0.6	V
"H" Level output	VoH		2.4	-	-	V
"L" Level output	VoL		-	-	0.4	V

## Optical Characteristics

Item	Symbol	Condition	Min.	Typ.	Max.	Unit
Viewing Angle – Vertical	AV	Cr ≥ 2	-60	-	+35	°
Viewing Angle - Horizontal	AH	Cr ≥ 2	-40	-	+40	°
Contrast Ratio	Cr		-	6	-	-
Response Time (rise)	Tr	-	-	150	250	ms
Response Time (fall)	Tf	-	-	150	250	ms

# Slave Address = 0x7C

Write mode

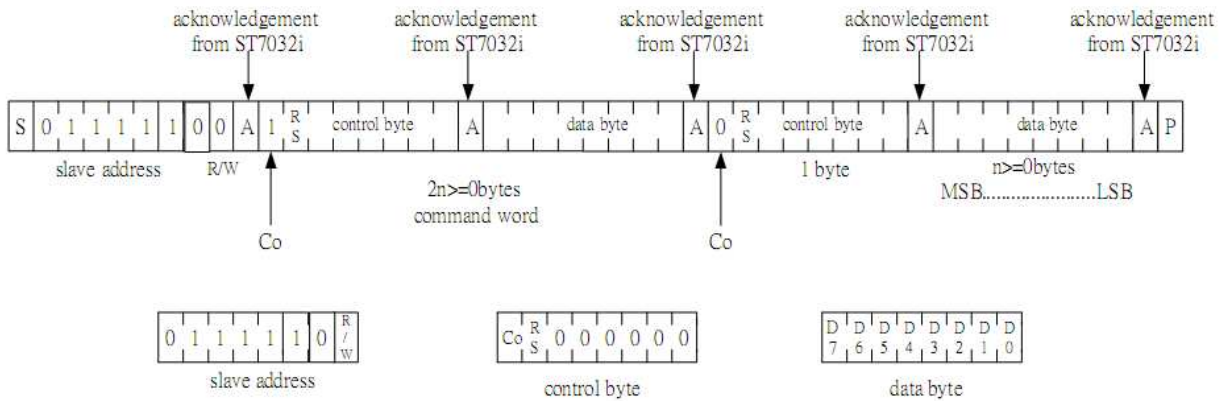

**Figure 5. 2-line Interface protocol**

Co	0	Last control byte to be sent. Only a stream of data bytes is allowed to follow. This stream may only be terminated by a STOP condition.
	1	Another control byte will follow the data byte unless a STOP condition is received.

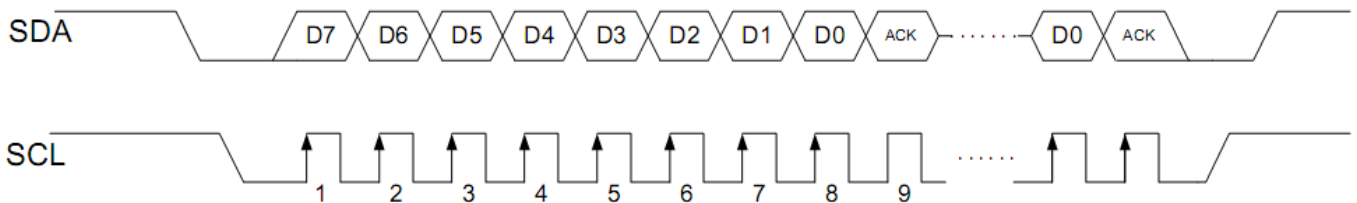

Display Position	1	2	3	4	5	6	.....	38	39	40
DDRAM Address (hexadecimal)	00	01	02	03	04	05	.....	25	26	27
	40	41	42	43	44	45	.....	65	66	67

## Controller Information

Built-in ST7032i-oD. Download specification at [http://www.newhavendisplay.com/app\\_notes/ST7032.pdf](http://www.newhavendisplay.com/app_notes/ST7032.pdf)

➤ **instruction table at "Extension mode"**

(when "EXT" option pin connect to VSS, the instruction set follow below table)

Instruction	Instruction Code										Description	Instruction Execution Time		
	RS	R/W	DB7	DB6	DB5	DB4	DB3	DB2	DB1	DB0		OSC=380KHz	OSC=540kHz	OSC=700KHz
Clear Display	0	0	0	0	0	0	0	0	0	1	Write "20H" to DDRAM, and set DDRAM address to "00H" from AC	1.08 ms	0.76 ms	0.59 ms
Return Home	0	0	0	0	0	0	0	0	1	x	Set DDRAM address to "00H" from AC and return cursor to its original position if shifted. The contents of DDRAM are not changed.	1.08 ms	0.76 ms	0.59 ms
Entry Mode Set	0	0	0	0	0	0	0	1	I/D	S	Sets cursor move direction and specifies display shift. These operations are performed during data write and read.	26.3 us	18.5 us	14.3 us
Display ON/OFF	0	0	0	0	0	0	1	D	C	B	D=1:entire display on C=1:cursor on B=1:cursor position on	26.3 us	18.5 us	14.3 us
Function Set	0	0	0	0	1	DL	N	DH	*0	IS	DL: interface data is 8/4 bits N: number of line is 2/1 DH: double height font IS: instruction table select	26.3 us	18.5 us	14.3 us
Set DDRAM address	0	0	1	AC6	AC5	AC4	AC3	AC2	AC1	AC0	Set DDRAM address in address counter	26.3 us	18.5 us	14.3 us
Read Busy flag and address	0	1	BF	AC6	AC5	AC4	AC3	AC2	AC1	AC0	Whether during internal operation or not can be known by reading BF. The contents of address counter can also be read.	0	0	0
Write data to RAM	1	0	D7	D6	D5	D4	D3	D2	D1	D0	Write data into internal RAM (DDRAM/CGRAM/ICONRAM)	26.3 us	18.5 us	14.3 us
Read data from RAM	1	1	D7	D6	D5	D4	D3	D2	D1	D0	Read data from internal RAM (DDRAM/CGRAM/ICONRAM)	26.3 us	18.5 us	14.3 us

Note \*: this bit is for test command, and must always set to "0"

**Instruction table 0 (IS=0)**

Cursor or Display Shift	0	0	0	0	0	1	S/C	R/L	x	x	S/C and R/L: Set cursor moving and display shift control bit, and the direction, without changing DDRAM data.	26.3 us	18.5 us	14.3 us
Set CGRAM	0	0	0	1	AC5	AC4	AC3	AC2	AC1	AC0	Set CGRAM address in address counter	26.3 us	18.5 us	14.3 us

**Instruction table 1 (IS=1)**

Internal OSC frequency	0	0	0	0	0	1	BS	F2	F1	F0	BS=1:1/4 bias BS=0:1/5 bias F2~0: adjust internal OSC frequency for FR frequency.	26.3 us	18.5 us	14.3 us
Set ICON address	0	0	0	1	0	0	AC3	AC2	AC1	AC0	Set ICON address in address counter.	26.3 us	18.5 us	14.3 us
Power/ICON control/Contrast set	0	0	0	1	0	1	Ion	Bon	C5	C4	Ion: ICON display on/off Bon: set booster circuit on/off C5,C4: Contrast set for internal follower mode.	26.3 us	18.5 us	14.3 us
Follower control	0	0	0	1	1	0	Fon	Rab2	Rab1	Rab0	Fon: set follower circuit on/off Rab2~0: select follower amplified ratio.	26.3 us	18.5 us	14.3 us
Contrast set	0	0	0	1	1	1	C3	C2	C1	C0	Contrast set for internal follower mode.	26.3 us	18.5 us	14.3 us



# Timing Characteristics

( Ta = -30°C to 85°C )

Item	Signal	Symbol	Condition	VDD=2.7 to 4.5V Rating		VDD=4.5 to 5.5V Rating		Units
				Min.	Max.	Min.	Max.	
SCL clock frequency	SCL	$f_{SCLK}$	—	DC	400	DC	400	KHz
SCL clock low period		$t_{LOW}$		1.3	—	1.3	—	us
SCL clock high period		$t_{HIGH}$		0.6	—	0.6	—	
Data set-up time	SI	$t_{SU:DAT}$	—	180	—	100	—	ns
Data hold time		$t_{HD:DAT}$		0	0.9	0	0.9	us
SCL,SDA rise time	SCL, SDA	$t_r$	—	$20+0.1C_b$	300	$20+0.1C_b$	300	ns
SCL,SDA fall time		$t_f$		$20+0.1C_b$	300	$20+0.1C_b$	300	
Capacitive load represent by each bus line		$C_b$	—	—	400	—	400	pf
Setup time for a repeated START condition	SI	$t_{SU:STA}$	—	0.6	—	0.6	—	us
Start condition hold time		$t_{HD:STA}$	—	0.6	—	0.6	—	us
Setup time for STOP condition		$t_{SU:STO}$	—	0.6	—	0.6	—	us
Bus free time between a Stop and START condition	SCL	$t_{BUF}$	—	1.3	—	1.3	—	us

- I2C interface

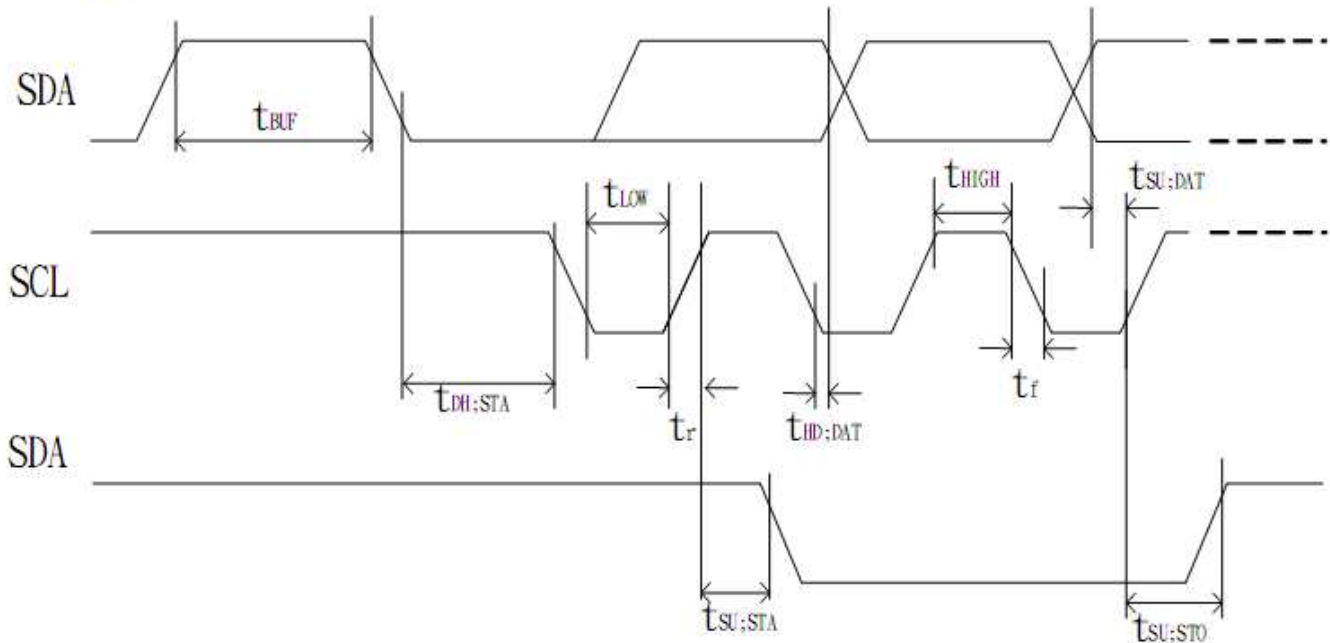



## Example Initialization Program

```
/******  
void I2C_out(unsigned char j)           //I2C Output  
{  
    int n;  
    unsigned char d;  
    d=j;  
    for(n=0;n<8;n++){  
        if((d&0x80)==0x80)  
            SDA=1;  
        else  
            SDA=0;  
        d=(d<<1);  
        SCL = 0;  
        SCL = 1;  
        SCL = 0;  
    }  
    SCL = 1;  
    while(SDA==1){  
        SCL=0;  
        SCL=1;  
    }  
    SCL=0;  
}  
/******  
void I2C_Start(void)  
{  
    SCL=1;  
    SDA=1;  
    SDA=0;  
    SCL=0;  
}  
/******  
void I2C_Stop(void)  
{  
    SDA=0;  
    SCL=0;  
    SCL=1;  
    SDA=1;  
}  
/******  
void Show(unsigned char *text)  
{  
    int n;  
    I2C_Start();  
    I2C_out(Slave);  
    I2C_out(Datasend);  
    for(n=0;n<16;n++){  
        I2C_out(*text);  
        ++text;  
    }  
    I2C_Stop();  
}  
/******
```

```
*      Initialization For ST7032i      *
*****/
void init_LCD()
{
I2C_Start();
I2C_out(0x7C);
I2C_out(0x00);
I2C_out(0x38);
delay(10);
I2C_out(0x39);
delay(10);
I2C_out(0x14);
I2C_out(0x78);
I2C_out(0x5E);
I2C_out(0x6D);
I2C_out(0x0C);
I2C_out(0x01);
I2C_out(0x06);
delay(10);
I2C_stop();
}
/*****/
```

## Quality Information

Test Item	Content of Test	Test Condition	Note
High Temperature storage	Endurance test applying the high storage temperature for a long time.	+80°C , 48hrs	2
Low Temperature storage	Endurance test applying the low storage temperature for a long time.	-30°C , 48hrs	1,2
High Temperature Operation	Endurance test applying the electric stress (voltage & current) and the high thermal stress for a long time.	+70°C , 48hrs	2
Low Temperature Operation	Endurance test applying the electric stress (voltage & current) and the low thermal stress for a long time.	-20°C , 48hrs	1,2
High Temperature / Humidity Operation	Endurance test applying the electric stress (voltage & current) and the high thermal with high humidity stress for a long time.	+40°C , 90% RH , 48hrs	1,2
Thermal Shock resistance	Endurance test applying the electric stress (voltage & current) during a cycle of low and high thermal stress.	0°C,30min -> 25°C,5min -> 50°C,30min = 1 cycle 10 cycles	
Vibration test	Endurance test applying vibration to simulate transportation and use.	10-55Hz , 15mm amplitude. 60 sec in each of 3 directions X,Y,Z For 15 minutes	3
Static electricity test	Endurance test applying electric static discharge.	VS=800V, RS=1.5kΩ, CS=100pF One time	

**Note 1:** No condensation to be observed.

**Note 2:** Conducted after 4 hours of storage at 25°C, 0%RH.

**Note 3:** Test performed on product itself, not inside a container.

## Precautions for using LCDs/LCMs

See Precautions at [www.newhavendisplay.com/specs/precautions.pdf](http://www.newhavendisplay.com/specs/precautions.pdf)

## Warranty Information and Terms & Conditions

[http://www.newhavendisplay.com/index.php?main\\_page=terms](http://www.newhavendisplay.com/index.php?main_page=terms)